

### FLOAT-A-SHAFT® Standard Series – 2:1 Ratio

Standard Mount - Low Torque - Journal Bearing

MODEL	R/LH	BORES
0303-0000	LH	1/2" X 3/4"
0304-0000	RH	1/2" X 3/4"
0307-0000	LH	1/2" X 1"
0308-0000	RH	1/2" X 1"
0311-0000	LH	1/2" X 1-1/4"
0312-0000	RH	1/2" X 1-1/4"
0317-0000	LH	5/8" X 3/4"
0318-0000	RH	5/8" X 3/4"
0321-0000	LH	5/8" X 1"
0322-0000	RH	5/8" X 1"
0325-0000	LH	5/8" X 1-1/4"
0326-0000	RH	5/8" X 1-1/4"

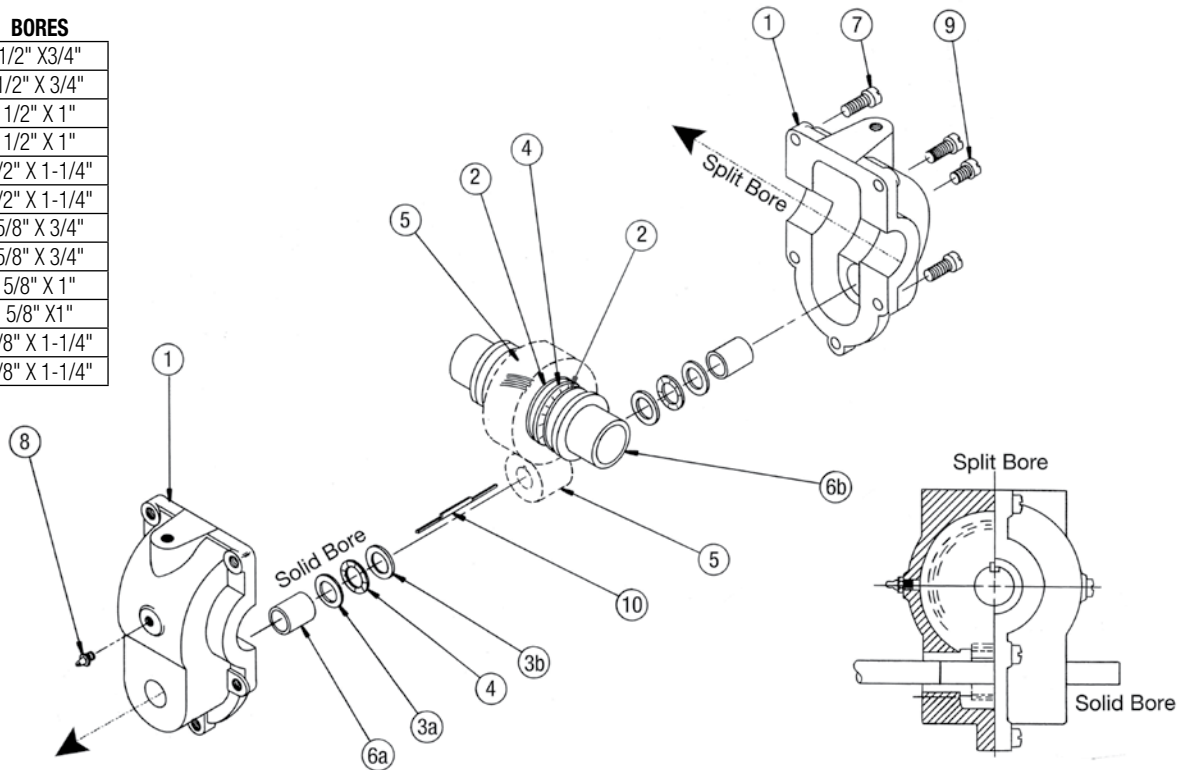

ITEM	PART NO.	DESCRIPTION	QUANTITY											
			0303-0000	0304-0000	0307-0000	0308-0000	0311-0000	0312-0000	0317-0000	0318-0000	0321-0000	0322-0000	0325-0000	0326-0000
1.	0321-9021	GEAR CASE HOUSING	1	1	1	1			1	1	1	1		
	0325-9025	GEAR CASE HOUSING					1	1					1	1
2.	0200-1312	WASHER, THRUST, 3/4" BORE	4	4					4	4				
	0200-1316	WASHER, THRUST, 1" BORE			4	4					4	4		
	0200-1320	WASHER, THRUST, 1-1/4" BORE					4	4					4	4
3.	0100-1308	WASHER, THRUST, 1/2" BORE (3A)	2	2	2	2	2	2						
	0100-1310	WASHER, THRUST, 5/8" BORE (3A)							2	2	2	2	2	2
	0100-4308	WASHER, 1/2" BORE, CARB. (3B)	2	2	2	2	2	2						
	0100-4310	WASHER, 5/8" BORE, CARB. (3B)							2	2	2	2	2	2
4.	0100-1208	BEARING, THRUST, 1/2" BORE	2	2	2	2	2	2						
	0100-1210	BEARING, THRUST, 5/8" BORE							2	2	2	2	2	2
	0200-1212	BEARING, THRUST, 3/4" BORE	2	2					2	2				
	0200-1216	BEARING, THRUST, 1" BORE			2	2					2	2		
	0200-1220	BEARING, THRUST, 1-1/4" BORE					2	2					2	2
5.	0100-1108	GEAR, 10 T, LH, 1/2" BORE	1		1		1							
	0100-2108	GEAR, 10 T, RH, 1/2" BORE		1		1		1						
	0100-1110	GEAR, 10 T, LH, 5/8" BORE							1		1		1	
	0100-2110	GEAR, 10 T, RH, 5/8" BORE										1		1
	0300-1112	GEAR, 20 T, LH, 3/4" BORE	1						1					
	0300-2112	GEAR, 20 T, RH, 3/4" BORE		1						1				
	0300-1116	GEAR, 20 T, LH, 1" BORE			1						1			
	0300-2116	GEAR, 20 T, RH, 1" BORE				1						1		
	0300-2120	GEAR, 20 T, LH, 1-1/4" BORE					1						1	
	0300-2120	GEAR, 20 T, RH, 1-1/4" BORE						1						1

Drawing repeated for reference

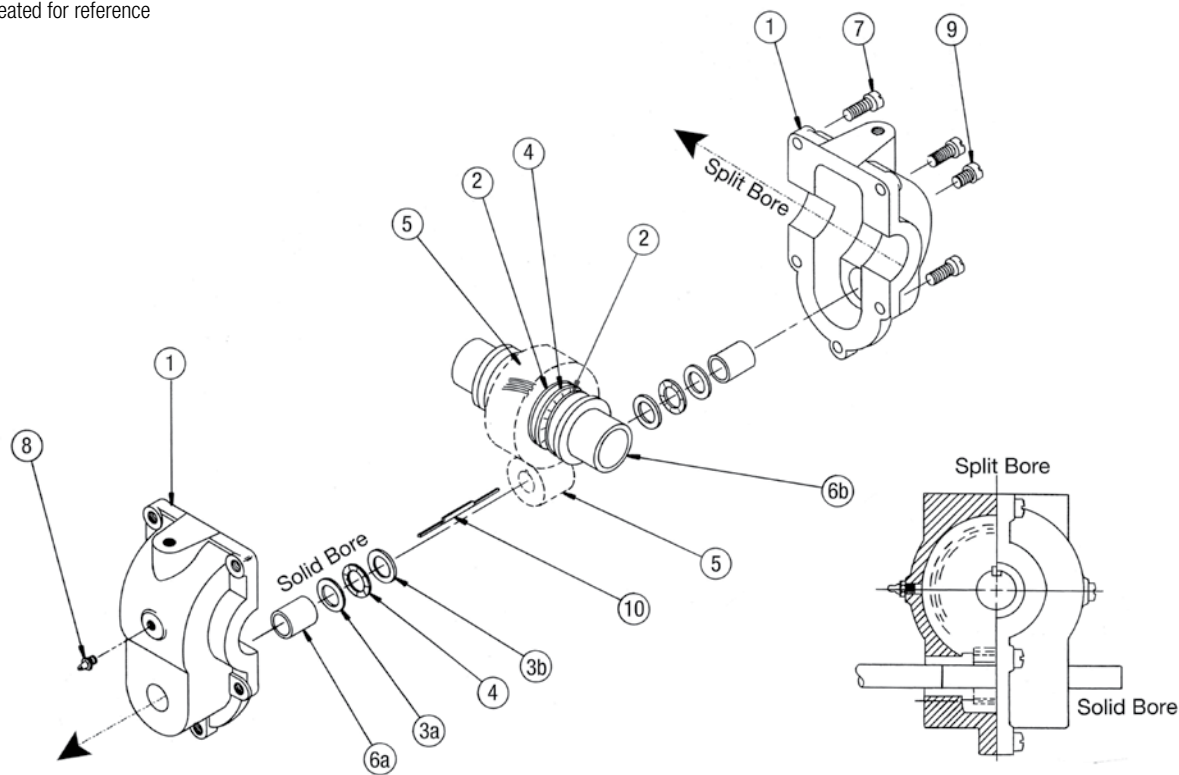

ITEM	PART NO.	DESCRIPTION	QUANTITY													
			0303-0000	0304-0000	0307-0000	0308-0000	0311-0000	0312-0000	0317-0000	0318-0000	0321-0000	0322-0000	0325-0000	0326-0000		
6.	0100-3408	BUSHING, BRONZE, 1/2" BORE (6A)	2	2	2	2	2	2								
	0100-3410	BUSHING, BRONZE, 5/8" BORE (6A)							2	2	2	2	2	2	2	2
	0200-3512	BUSHING, BRONZE, FLANGED, 3/4" BORE (6B)	2	2					2	2						
	0200-1516	BUSHING, BRONZE, FLANGED, 1" BORE (6B)			2	2					2	2				
	0200-3520	BUSHING, BRONZE, FLANGED, 1-1/4" BORE (6B)					2	2							2	2
7.	0200-1810	SCREW, FILL HD, 1/4-20	5	5	5	5	5	5	5	5	5	5	5	5	5	5
8.	0100-1601	ZERK GREASE FITTING, 1/4-28	1	1	1	1	1	1	1	1	1	1	1	1	1	1
9.	0100-2604	SCREW, FILL HD, 1/4-28	1	1	1	1	1	1	1	1	1	1	1	1	1	1
10.	0100-1502	KEY, STEP, 1/8" X 1/8"	1	1	1	1	1	1								
	0100-1503	KEY, STEP, 1/8" X 7/64"							1	1	1	1	1	1	1	1
	0200-1503	KEY, STEP, 3/16" X 3/16"	1	1					1	1						
	0200-1504	KEY, STEP, 1/4" X 1/4"			1	1	1	1				1	1	1	1	1

Drawing repeated for reference

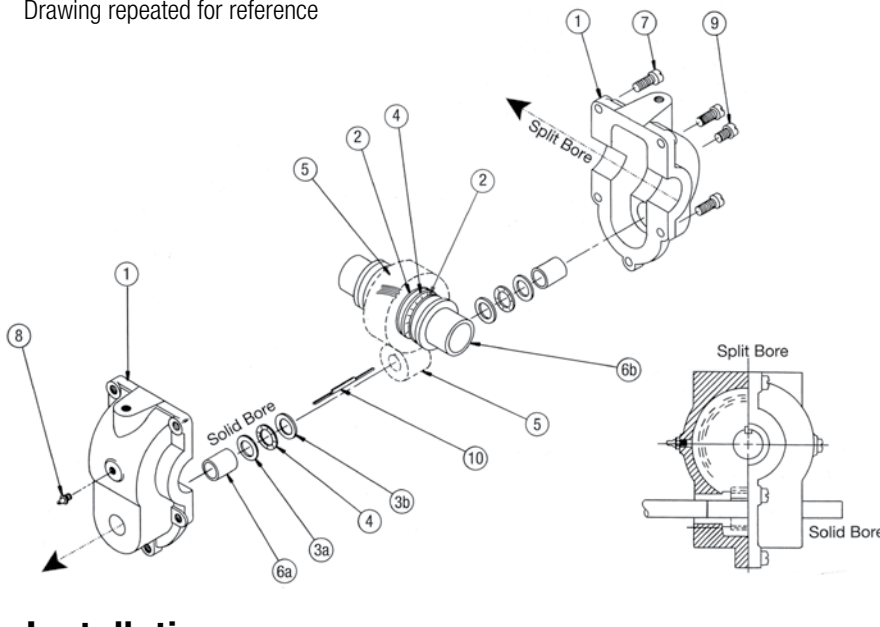

place a Thrust Washer (2), a Thrust Bearing (4), another Thrust Washer (2), and the other Flanged Bushing (6b)—flanged end toward gears. Position this assembly into the Gear Case Housing (1), making sure the teeth of the gears mesh. **CAUTION:** When trying to get the gears to mesh, rotate the gears to prevent possible damage to the teeth. Next, make sure the Flanged Bushings (6b) are pushed all the way into the casting to allow maximum clearance between the gear and the bushings. To complete the assembly, install the other half of the Gear Case Housing (1) with the Bushing (6a) already inserted, and tighten the Screws (7) in the order shown here. In case of shaft

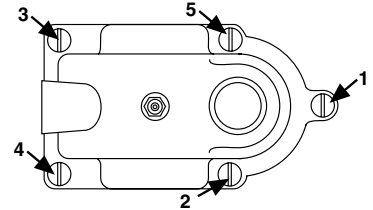

**Installation**

**Full Length Shaft Keyway:**

Keyway extends to end of shaft. In this case, it is not necessary to disassemble the Float-A-Shaft®. Without removing the plastic tubes, align the Float-A-Shaft® with the shaft on which it is to be used and gently press it on. Be sure the key is properly oriented with the keyway. The plastic tubes will fall out as the shaft extends through the unit. The plastic tubes should be saved if removal of the Float-A-Shaft® is required. Be sure the plastic tubes are inserted as the shaft is withdrawn, otherwise the internal parts will slip out of position and disassembly may be required to restore proper alignment.

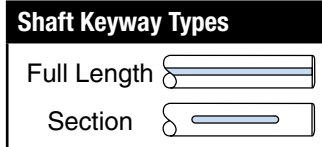

**Section Keyway:** Keyway does not extend to end of shaft. The Float-A-Shaft® must be disassembled for installation.

**Reassembly:** Reference the numbering diagram on page 1 to complete the following instructions, matching the numbers with corresponding bores.

**Solid Bore Reassembly:** Slide one end of the Gear Case Housing (1), which has the Bushing (6a) already inserted onto the most accessible end of one shaft. Install a Thrust Washer (3a), a Thrust Bearing (4), and another Thrust Washer (3b)(Note: this is a thicker washer). Next, place the Key (10) in the keyway and slide the Gear (5) onto the shaft over the key. On the opposite side of the gear, place a Thrust Washer (3b), a Thrust Bearing (4), and another Thrust Washer (3a).

**Split Bore Reassembly:** Slide the following parts onto the shaft, which is positioned at a 90° angle: a Flanged Bushing (6b)—flanged end toward gears, a Thrust Washer (2), a Thrust Bearing (4), and another Thrust Washer (2). Place the Key (10) in the keyway and slide the Gear (5) onto the shaft over the key. On the opposite side of the gear,

binding, check for possible misalignment of the shafts or for an oversized shaft diameter. Insert Zerk Grease Fitting (8) and Screw (9).

**Shaft Requirements:** Shafts should be made of power transmission steel grade 4140 or better. A tolerance of +.000/- .002 is recommended for the shaft diameters. The shaft surfaces should be 32 RMS maximum for stationary applications, and 16 RMS maximum for traversing applications. Shaft straightness should be .0015 TIR per foot.

**LUBRICATION AND MAINTENANCE SCHEDULE:** All Float-A-Shaft® gear boxes have been lubricated at the factory with Mobilith® SHC 460. Standard Float-A-Shaft® gear boxes are initially filled with 2.8 oz. (82.8 ml) of grease to achieve 54% fill on the units. However, units require more lubrication prior to operation. Periodic re-lubrication is also necessary for optimum performance. When re-lubricating, inject Mobilith® SHC 460 (maximum operating temperature of 300°F or higher and EP rated) into gear case, as required, via the grease zerk provided. *Mobilith® SHC 460 - 14 oz grease cartridge • P/N 0100-1605*

Lubrication and maintenance schedules are dependent on the application. General guidance is provided below and a maintenance plan can be developed based on the use case.

MAINTENANCE	USE CASE		
	Continuous/ Heavy Duty	Intermittent/ Light Duty	Minimal
Inject 1/4 oz. of Mobilith SHC460 into gear housing	1 1/2 Months	3 Months	6 Months
Disassemble and purge unit. Hand lubricate all bearings and gears with 3 oz. of Mobilith SHC460	6 Months	1 Year	1 Year

Mobilith® SHC 460 is a registered trademark of Exxon Mobil Corporation, www.mobil.com  
Float-A-Shaft® is a registered trademark of Tolomatic, Inc.



COMPANY WITH  
QUALITY SYSTEM  
CERTIFIED BY DNV  
= ISO 9001 =

3800 County Road 116, Hamel, MN 55340 USA  
http://www.Tolomatic.com • Email: Help@Tolomatic.com  
Phone: (763) 478-8000 • Fax: (763) 478-8080 • Toll Free: 1-800-328-2174

© 2024 Tolomatic 202405091243

All brand and product names are trademarks or registered trademarks of their respective owners. Information in this document is believed accurate at time of printing. However, Tolomatic assumes no responsibility for its use or for any errors that may appear in this document. Tolomatic reserves the right to change the design or operation of the equipment described herein and any associated motion products without notice. Information in this document is subject to change without notice.

Visit www.tolomatic.com for the most up-to-date technical information