

### LS05 & LSMM05 Linear Slide

1/2" (12mm) Bore

Replaced Parts Sheets  
0600-0003 & 0600-0004

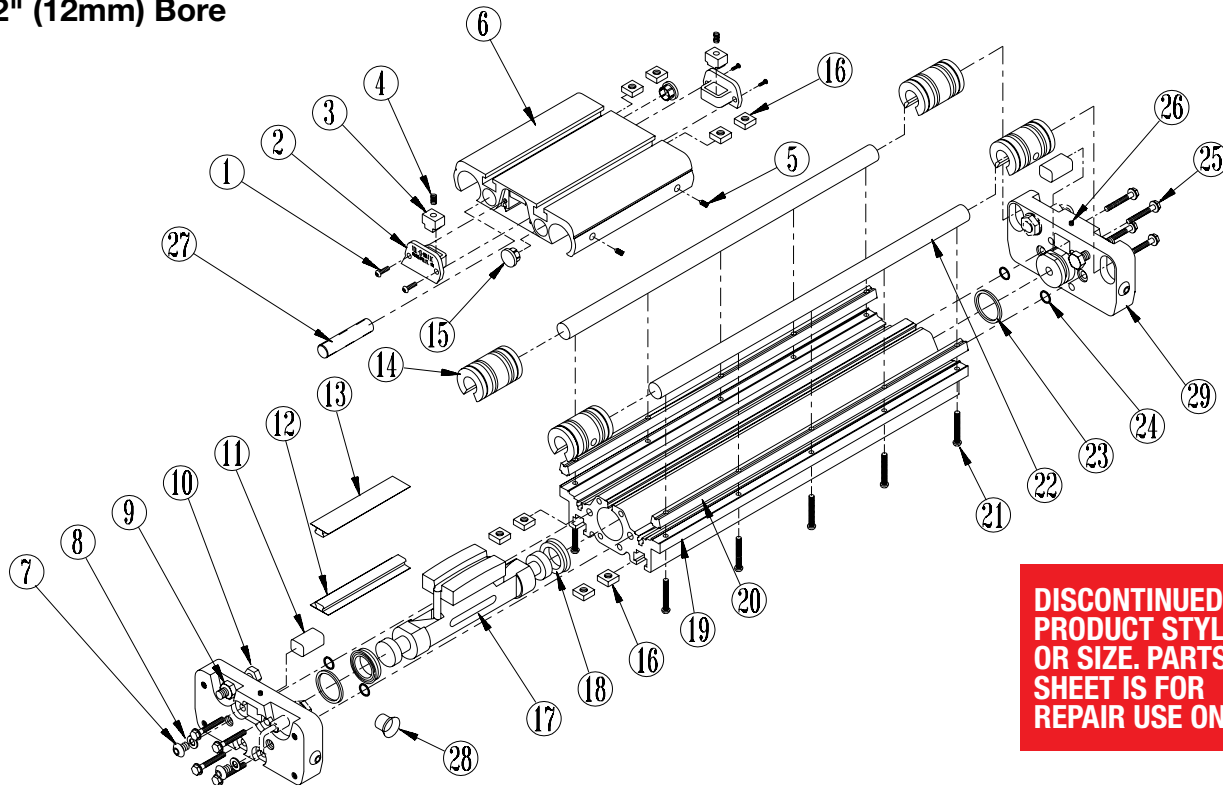

**DISCONTINUED  
PRODUCT STYLE  
OR SIZE. PARTS  
SHEET IS FOR  
REPAIR USE ONLY.**

#### List of Parts

ITEM	Part No. or Config Code	DESCRIPTION	LS05	LSMM05
1. <sup>1</sup>	0910-1172	Screw	4	4
2. <sup>1</sup>	0605-1012	End Cap	2	2
3. <sup>1</sup>	0605-1013	Band Insert	2	2
4. <sup>1</sup>	0605-1008	Spring, Compression	2	2
5.	0605-1102	Screw	4	4
6. <sup>5</sup>	0605-9000	Carrier Sub-Assembly	1	1
7. <sup>1,2</sup>	0605-1016	Button Head Cap Screw	4	-
	5605-1016	Button Head Cap Screw, Metric	-	4
8. <sup>1,2</sup>	0605-1021	Gasket, Buna-N	4	4
9. <sup>3</sup>	0605-1010	Nut, Hex	2	2
10. <sup>3</sup>	0605-1034	Screw, Hex	2	2
11.	0605-1017	Band Wedge	2	2
12. <sup>1</sup>	NSBLS05	(0905-9001) Sealing Band (specify stroke)	1	1
13. <sup>1</sup>	NDBLS05	(0905-9003) Dust Band (specify stroke)	1	1
14.	0605-1103	Composite Bearing	4	4
15. <sup>4</sup>	0605-1032	Hole Plug, Chrome	4	4

ITEM	Part No. or Config Code	DESCRIPTION	LS05	LSMM05
16.	0605-1042	Square Nut	8	-
	5605-1042	Square Nut, Metric	-	8
17.	0905-1010	Piston-Bracket	1	1
18. <sup>1</sup>	0905-1015	U-Cup	2	2
19.	0605-1001	Cylinder Tube (specify stroke)	1	1
20.	0605-1031	V-Block Machined (specify stroke)	2	2
	0605-1101	Cap Screw (Qty. depends on stroke)	A/R	-
21.	0605-1035	Cap Screw, Metric (Qty. depends on stroke)	-	A/R
	0605-1004	Shafting, Machined (specify stroke)	2	2
22.	0605-1004	Shafting, Machined (specify stroke)	2	2
23. <sup>1</sup>	0905-1005	O-Ring, Buna-N	2	2
24. <sup>1</sup>	0701-1003	O-Ring, Buna-N	4	4
25.	0605-1011	Screw, Self Tapping	8	8
26. <sup>2</sup>	0905-1006	Set Screw	2	2
27.	0605-1066	Stop Screw	2	2
28.	0605-1015	Plug, Head	2	2
29.	0605-9002	Head Sub Assembly	2	-
	5605-9002	Head Sub Assembly, Metric	-	2

<sup>1</sup>Parts are included in repair kit RKLS(MM)05SK\_...<sup>2</sup>Parts are part of Head Assembly 0605-9002 (5605-9002 metric).

<sup>3</sup>Items are part of Button Head Screw Assembly 0605-9003. <sup>4</sup>Hole Plug is only used with Proximity Sensors.

<sup>5</sup>Carrier Sub Assemblies prior to 7/9/97 are not interchangeable with current bearings. Actuators purchased prior to 7/9/97 will require ordering 0605-9000-Carrier (#6), in addition to 0605-1103-Bearing (#14), and 0605-1102-Screw (#5).

**Disassembly**

1. Remove Slide Cylinder from machinery.
2. Remove Screws (#1), and End Caps (#2). \*Use care as End Caps (#2) are spring loaded.
3. Loosen set screws in Head Assemblies (#29).
4. Remove eight Screws (#25), and two Head Assemblies(#29).
5. Slide Piston/Bracket (#17) and Carrier (#6) out end of Tube/Base (#19).
6. Remove Screws (#5), and Bearings (#14), from Carrier (#6).
7. Remove Top Dust Band (#13).
8. Remove Inside Sealing Band (#12) by passing a screw driver or similar tool through the slot in the Tube/Base (#19) to dislodge the band. **NOTE:** Take care to ensure NO SCRATCHES ARE MADE in the Tube/Base (#19) bore or slot.

**Assembly**

1. Thoroughly clean all components, particularly the bore, slot, and bands. **Carefully lubricate the tube and all rubber parts including the rubber on both the inside and outside bands with MAGNALUBE® "G" grease.**
2. Insert new Sealing Band (#12) into the Tube/Base (#19) bore (with rubber portion facing up into slot), centering the band along its entire length. **CAUTION:** The metal edges of the band are very sharp. Exercise caution when installing both the Inner and Top Bands to avoid injury to yourself or the Band and Tube/Base (#19).
3. Install the Piston/Bracket (#17), with new U-Cups (#18) in place, in the Tube/Base by passing the Inner Sealing Band through the Piston/Bracket.
4. Push the Piston/Bracket (#17) along the cylinder length to position the Inner Band (#12) properly into the slot.
5. Cut Sealing Band (#12) to leave 1/2" overhang at either end of the Tube/Base. Remove rubber portion of overhanging band with a razor blade.
6. Install the Top Dust Band (#13) with the rubber sealing portion facing down into the slot and centering the band along its entire length. The band should lay over the center of the Piston/Bracket.
7. Cut Dust Band (#13) to leave 1/2" overhang at either end of the Tube/Base. Remove rubber portion of overhanging band with a razor blade.
8. Place two Bearings (#14) on each shaft (#22).
9. Install Carrier (#6) over Piston/Bracket (#17) with one bearing (#14) per Shaft (#22) on either side of the Carrier (#6).
10. Push Bearings (#14) in Carrier (#6) as far as Carrier (#6) bores will permit.
11. Apply **LOCTITE® #242** to Screws (#5) and screw them into Carrier (#6).
12. Install Springs (#4) and Band Inserts (#3) into End Caps (#2) and install in Carrier (#6) ends. Push Springs (#4) down to clear underside of Carrier (#6). Use Screws (#1) to hold End Cap (#2) in place.
13. Place Band Wedges (#11) between Bands (#12,#13) at both ends of cylinder.
14. Install new O-Rings (#23,#24) on Head Assemblies (#29) and install Head Assemblies to cylinder. If using Square Nuts (#16) be sure they are installed in Tube/Base before Heads are installed.
15. Install Screws (#25) and tighten Head Assemblies (#29) in place.
16. Push Carrier (#6) to one end and tighten Set Screw in Head Assembly on that end. Push Carrier (#6) to the other end of Slide Cylinder to remove any slack in Bands (#12,#13) and tighten Set Screw in Head Assembly.
17. Run Carrier back and forth along the full stroke to make certain that the slide is properly assembled.
18. Re-mount the completed Slide Cylinder.

**Shaft and Bearing Replacement Instructions**

**NOTE:** Shaft alignment is critical to assure proper function of the slide cylinder.

1. Remove Slide Cylinder from machinery.
2. Loosen two Set Screws in Head Assembly (#29) on one end of Cylinder.
3. Remove four screws (#25), and Head Assembly (#29) from same end of Cylinder.
4. Remove Screws (#21) from one shaft (#22).
5. Slide Shaft (#22) out of Carrier (#6).
6. Remove and replace Set Screws (#5) and Bearing (#14) from open side of Carrier (#6). Use **LOCTITE® #242** on Set Screws (#5) and screw them into Carrier (#6).
7. Slide new Shaft (#22) through Bearings (#14). Replace Screws (#21) loosely, use **LOCTITE® #242** on Screws (#21).
8. Hold Top Dust Band (#13) at open end of Cylinder and slide Carrier (#6) to opposing end.
9. Tighten Screws (#21) below Carrier (#6) to 15 inch-pounds (20.34 N-m) minimum.
10. To align Shaft (#22) properly, slide carrier over next Screw (#21) and tighten to 15 inch-pounds (20.34 N-m) minimum. Repeat this until all Screws (#21) are tight.
11. Repeat steps 5 through 11 for second Shaft (#22).
12. Place Band Wedge (#11) between Bands (#12,#13) at open end of Cylinder.
13. Be sure O-rings (#23,#24) are on Head Assembly (#29) and install Head Assembly (#29) to Cylinder. If using Square Nuts (#16) be sure they are installed in Tube/Base (#19) before Head is installed.
14. Install four Screws (#25) and tighten to 45 inch-pounds.
15. Position Carrier (#6) to the end of Cylinder with non-removed Head Assembly (#29). Push Carrier (#6) back to other end to remove any slack from Bands (#12,#13) and tighten Set Screws in Head Assembly (#29).
16. Run Carrier back and forth along the full stroke to make certain the Slide is properly assembled before applying air.
17. Re-mount the completed SLIDE CYLINDER.

**DISCONTINUED PRODUCT STYLE OR SIZE.  
PARTS SHEET IS FOR REPAIR USE ONLY.**

**OPTIONAL ACCESSORIES****Shock Absorbers (sold individually)**

Description	Part No.
1/2"/12mm – Light Duty	0605-9008
1/2"/12mm – Heavy Duty	0605-9009

**Inductive DC Proximity Sensors (sold individually)**

Description	Part No.
DC 10-24 NPN NO Sink	0605-1023
DC 10-24 PNP NO Source	0605-1024

**NOTE:** NO=Normally Open

Loctite® is a registered trademark of the Loctite Corporation, [www.loctite.com](http://www.loctite.com)  
 Magnalube®-G is a registered trademark of the Carleton-Stuart Corporation, [www.magnalube-g.com](http://www.magnalube-g.com)  
 Viton® is a registered trademark of the E.I. Du Pont de Nemours Co., [www.dupont.com](http://www.dupont.com).

**DISCONTINUED PRODUCT STYLE OR SIZE.  
PARTS SHEET IS FOR REPAIR USE ONLY.**

**SWITCH AND HARDWARE LISTING**

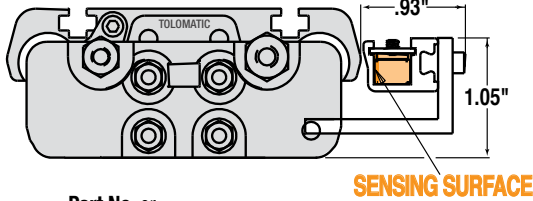

**LS(MM)05**

Part No. or ITEM CONFIG. code	DESCRIPTION	
RT	Switch, Reed, Form A, 5M Wire	AR
RM	Switch, Reed, Form A, Male Connect	AR
BT	Switch, Reed, Form C, 5M Wire	AR
BM	Switch, Reed, Form C, Male Connect	AR
CT	Switch, Triac, 5M Wire	AR
CM	Switch, Triac, Male Connect	AR
TT	Switch, Hall, Sourcing, 5M	AR
TM	Switch, Hall, Sourcing, Male	AR
KT	Switch, Hall, Sinking, 5M	AR
KM	Switch, Hall, Sinking, Male	AR
0605-9100	Rail and Rail Hardware (specify stroke)	AR

**REED SWITCHES**

**NOTE:** Form A Reed Switches should not be used in TTL logic circuits. A voltage drop caused by the L.E.D. indicator will result. For applications where TTL circuits are used, please contact the factory.

**WARNING:** An ohmmeter is recommended for testing Reed Switches. NEVER use an incandescent light bulb as a high current rush may damage the switch.

Reed and TRIAC switches are only recommended for signalling position, not directly powering solenoids. For shifting a solenoid, a relay or resistor is recommended between it and the Reed Switch. Switch ratings must not be exceeded at any time.

**NOTE:** The side of the switch with the groove indicates the sensing surface. This must face toward the magnet.

**NOTE:** For Hall Effect Switch Magnet, be sure the S pole of the magnet (indicated with black dot) is facing toward the switch (down).

**TO ORDER RETROFIT KITS:** SW (then the model number and base size, and code for type of switch needed).

**EXAMPLE: SWLS05BT**

Where **SW** is the switch kit, **LS** is Linear Slide, **05** is the 1/2" size, and **BT** is a Form C Reed Switch with 5-meter lead.

All Switch Kits come with 1 switch and mounting hardware.

**UNIVERSAL SWITCH WIRING DIAGRAMS AND LABEL COLOR CODING**

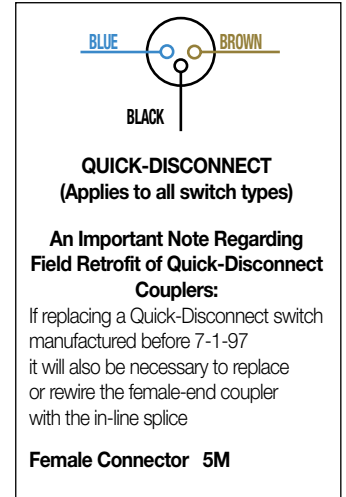
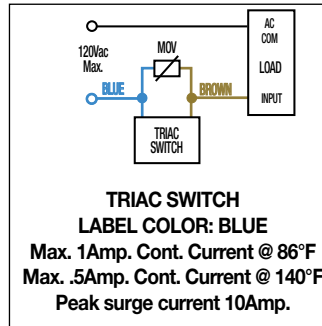
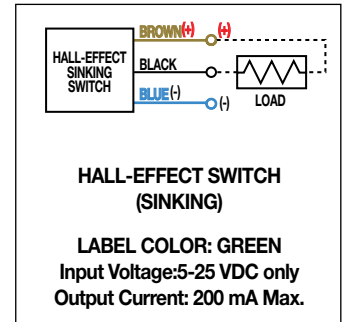
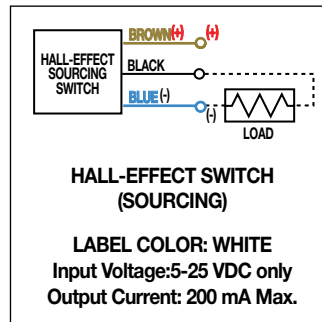
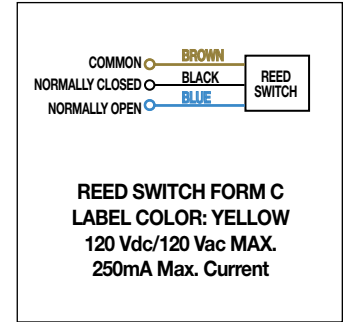
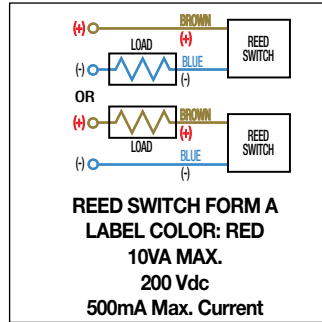

For complete Switch Performance Data, refer to the Tolomatic Fluid Power Catalog #9900-4000

**SWITCH TYPE CODE**

- BT** (Form C Reed Switch with 5-meter lead)
- BM** (Form C Reed Switch with 5-meter lead and QD)
- RT** (Form A Reed Switch with 5-meter lead)
- RM** (Form A Reed Switch with 5-meter lead and QD)
- CT** (TRIAC Switch with 5-meter lead)
- CM** (TRIAC Switch with 5-meter lead and QD)
- KT** (Hall-effect Switch (Sinking) 5-meter lead)
- KM** (Hall-effect Switch (Sinking) 5-meter lead and QD)
- TT** (Hall-effect Switch (Sourcing) 5-meter lead)
- TM** (Hall-effect Switch (Sourcing) 5-meter lead and QD)



COMPANY WITH QUALITY SYSTEM CERTIFIED BY DNV GL = ISO 9001 =

3800 County Road 116, Hamel, MN 55340 USA  
http://www.Tolomatic.com • Email: Help@Tolomatic.com  
Phone: (763) 478-8000 • Fax: (763) 478-8080 • Toll Free: 1-800-328-2174

© 2022 Tolomatic 202203101449

All brand and product names are trademarks or registered trademarks of their respective owners. Information in this document is believed accurate at time of printing. However, Tolomatic assumes no responsibility for its use or for any errors that may appear in this document. Tolomatic reserves the right to change the design or operation of the equipment described herein and any associated motion products without notice. Information in this document is subject to change without notice.

Visit [www.tolomatic.com](http://www.tolomatic.com) for the most up-to-date technical information