

# LS LINEAR SLIDE RODLESS CYLINDER



ABT

IXP

BC2

BC3

BC4

**LS**

MG

CC

PB

ENGR

## CONTENTS

Features .....	LS_2
LS10 .....	LS_4
Auxiliary Carrier .....	LS_6
LS Supports .....	LS_8
Switches .....	LS_9
Proximity Sensors .....	LS_11
Shock Absorbers .....	LS_12
Application Data Worksheet .....	LS_13
Selection Guidelines .....	LS_14
Application Guidelines .....	BC4_32
Service Parts .....	LS_15
Ordering .....	LS_16

# LS - LINEAR SLIDE

## ENDURANCE TECHNOLOGY<sup>SM</sup>

A Tolomatic Design Principle

*Endurance Technology features are designed for maximum durability to provide extended service life.*

Adapted from the popular BC2, the Linear Slide features 2 precision steel guide rods integrated with the extrusion to provide positive support of the load. This makes the Linear Slide more rugged and capable with greater load capacity and higher bending moments. Built-to-order in stroke lengths up to 110 inches (2,794mm).

### STAINLESS STEEL SEALING BAND SYSTEM



- Fatigue resistant stainless steel bands are specifically made to offer longer life and will not elongate like elastomers
- Outer band keeps out contaminants for extended performance
- Inner band provides a smooth surface for less seal wear

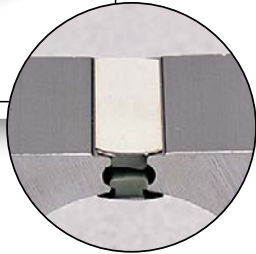

### FORMED END CAP WIPER SEAL

- Keeps contaminants from entering the sealing area
- Protects internal components
- Reduces maintenance while increasing productivity

### LOW CARRIER HEIGHT

- Reduces overall actuator envelope
- Large mounting area for high load stability
- T-Slots for mounting flexibility

### STROKE ADJUSTMENT

- End of stroke
- Integrated into design

### 3-PORTED HEADS

- Single End Porting
- Standard feature
- Simplifies air connections

### FORMED STEEL PISTON BRACKET

- Provides maximum strength at major stress points
- Heat treated carbon steel withstands the toughest dynamic forces
- Strongest bracket design in the industry assures long life with less maintenance

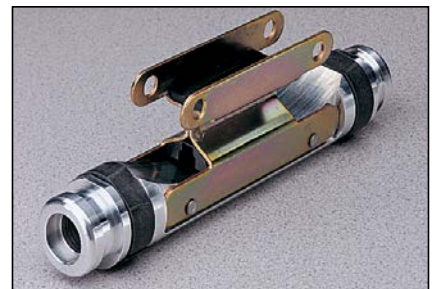

ABT  
MXP  
BC2  
BC3  
BC4  
LS  
MG  
CC  
PB  
ENGR

# TOLOMATIC... THE RODLESS CYLINDER LEADER

## STEEL GUIDE RODS

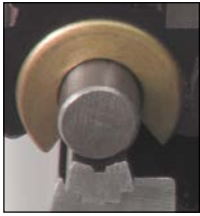

Two precision ground steel guide rods integrated with extrusion provides positive support of load

## RETAINED DUST BAND

Retained dust band keeps contaminants from entering the cylinder interior, protecting components for reduced maintenance and increased uptime

## RIGID BLACK-ANODIZED EXTRUDED ALUMINUM TUBE

- Stronger, stiffer tube retains tolerance specs when chamber is pressurized
- Keeps sealing band in place for maximized air efficiency
- Tube supports are minimized
- Solid structural support provides durability and long life performance

## LOAD-BEARING CARRIER DESIGN

- Load and piston are independent - piston floats, resulting in less friction and longer seal life
- Bearings offer consistently low friction and long wear; 1/2" bore features composite bearings, 1" bore features precision linear ball bearings

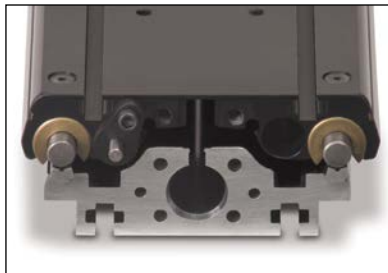

NOTE: Boxed letters indicate ordering codes

## OPTIONS



### AUXILIARY CARRIER **D****W** **D****O**

- Substantially higher load capacity
- Substantially higher bending moment capacity



### SUPPORTS **M****P**

- Used for intermediate support
- Flush with bottom of actuator to retain low profile
- Drop-in, adjustable mounting locations



### T-NUTS

- Used for intermediate support, combine with Tube Supports or mount directly to surface



### SHOCK ABSORBERS **S****L** **S****H**

- Smooth deceleration
- Allows increased operating speed
- Self-compensates for load or speed changes
- Minimizes impact load to equipment
- Higher equipment productivity
- Integrated to carrier design



### SWITCHES

- Available in Proximity, Reed, Hall-effect and Triac
- 15ft. cable with flying leads; available with quick-disconnect couplers

ABT

MXP

BC2

BC3

BC4

LS

MG

CC

PB

ENGR

# LS10 Linear Slide Rodless Cylinder

## PERFORMANCE

LS10



LS010 OPTIONS	Page
Auxiliary Carrier	LS_6
Proximity Sensors	LS_11
Shock Absorbers	LS_12
Switches	LS_9
Supports	LS_8
MORE INFORMATION	Page
Ordering	LS_16
Selection	LS_14

## BEARING LIFE vs LOAD

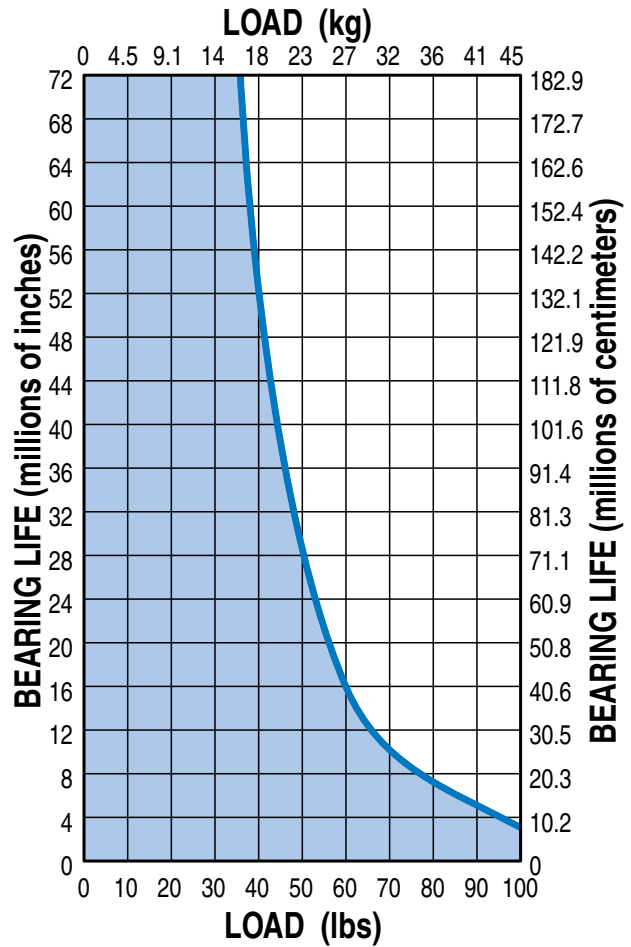

## THEORETICAL FORCE vs PRESSURE

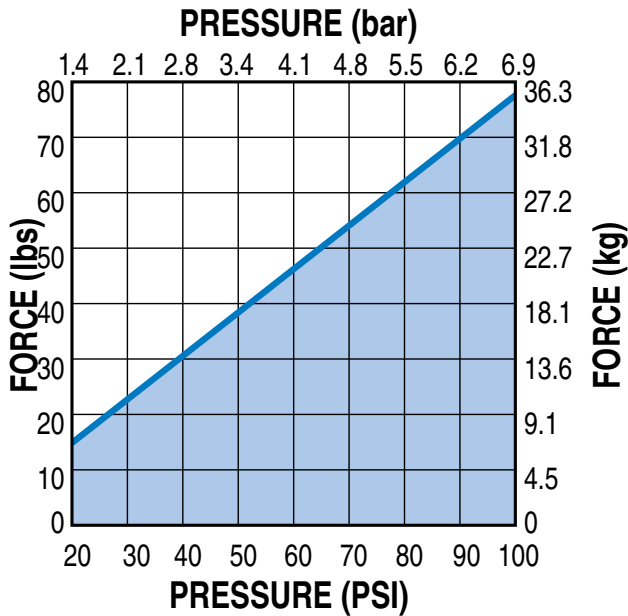

## SPECIFICATIONS

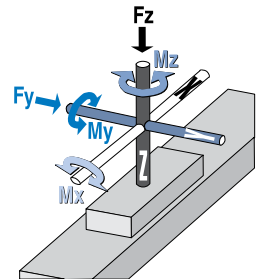

## LS10 BENDING MOMENTS AND LOAD

	BORE SIZE	MAX. BENDING MOMENT			MAX. LOAD
		My	Mx	Mz	Fz
<b>U.S.</b>	1.00 in	80 in-lbs	80 in-lbs	125 in-lbs	100 lbs
<b>Metric</b>	25 mm	9.0 N-m	9.0 N-m	14.0 N-m	45.4 kg

# LS10 Linear Slide Rodless Cylinder

## DIMENSIONS

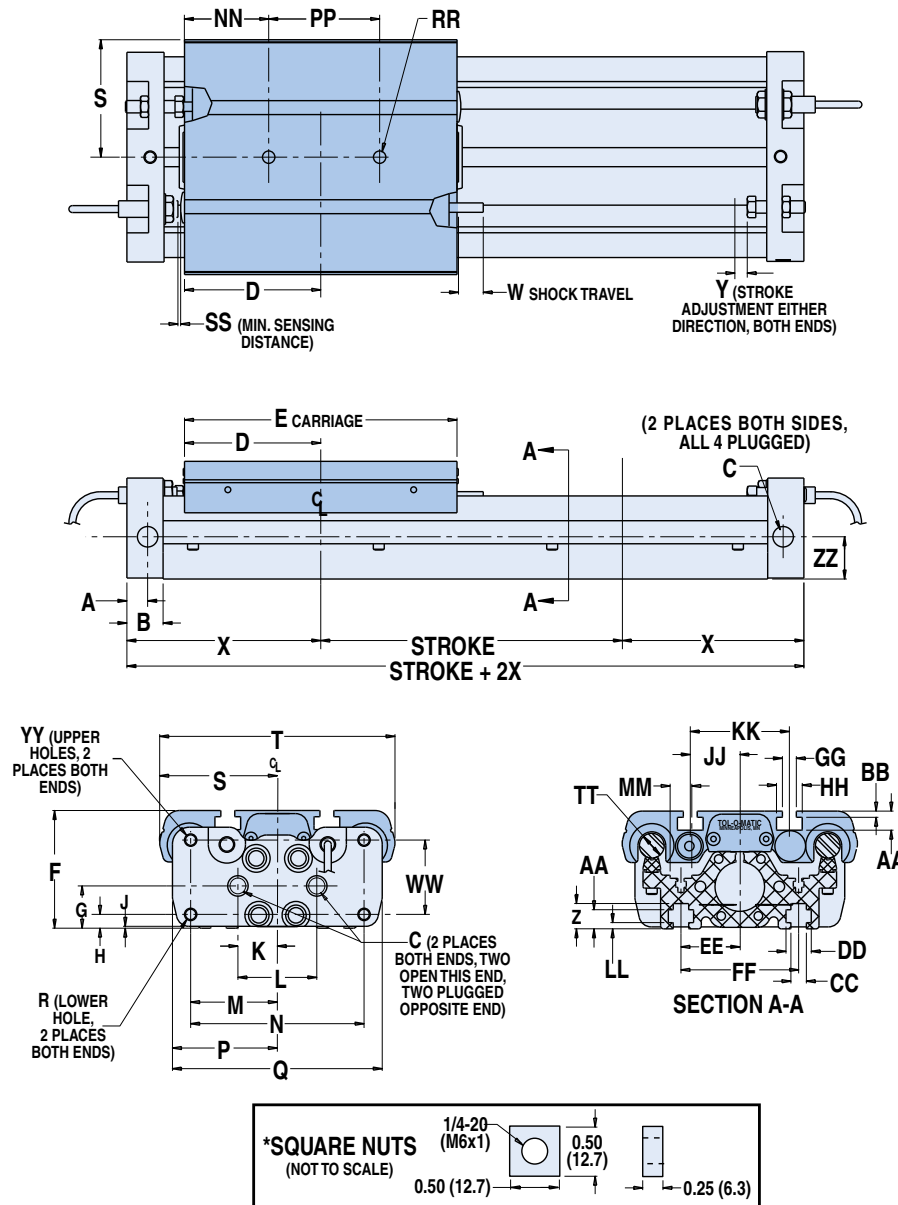

**\*NOTE:** Four square nuts are provided with each linear slide for base mounting. Additionally 2 square nuts are provided for 30" of stroke and 2 for every 20" of stroke thereafter.

	U.S.	Metric
A	0.42	10.7
B	0.73	18.5
C	1/8 NPT PORT	G 1/8-28 Parallel
D	2.75	69.9
E	5.50	139.7
F	2.38	60.5
G	0.86	21.7
H	0.28	7.1
J	0.04	1.0
K	0.80	20.3
L	1.59	40.4
M	1.75	44.5
N	3.50	88.9
P	2.13	54.1
Q	4.25	107.9
R	1/4-20 x .50 DP	M6 x 1.0 x 12 DP
S	2.38	60.5
T	4.75	120.7
W	0.43	10.9
X	3.89	98.8
Y	0.25	6.4
Z	0.51	12.9
AA	0.39	9.8
BB	0.10	2.5
CC	0.31	7.9
DD	0.51	13.0
EE	1.19	30.2
FF	2.38	60.3
GG	0.28	7.1
HH	0.52	13.2
JJ	1.00	25.4
KK	2.00	50.8
LL	0.13	3.2
MM	0.44	11.1
NN	1.75	44.5
PP	2.00	50.8
RR	.25 x .20 DP	6.35 x 5.1 DP
SS	0.04	1.0
TT	.472 Nominal	12.0 Nominal
WW	1.50	38.1
YY	1/4-20 x .38 DP	M6 x 1.0 x 9 DP
	INCHES	MILLIMETERS

## SPECIFICATIONS

	BORE SIZE	WEIGHT		MAX. STROKE LENGTH*	MAX. PRESSURE	TEMPERATURE RANGE	END-OF-STROKE POSITIONING ACCURACY	STROKE ADJUSTMENT
		BASE	PER UNIT OF STROKE					
<b>U.S.</b>	1.00 in	5.2 lbs	0.4 lbs/in	110 in	100 PSI	20° to 140° F	±0.0005 in	±0.25 in per end
<b>Metric</b>	25 mm	2.36 kg	0.181 kg/mm	2794 mm	6.895 bar	-7° to 60° C	0.0127 mm	±6.35 mm per end

**\*For longer strokes, alternate materials, mounting and/or fasteners – consult Tolomatic**

# LS Auxiliary Carrier - All Sizes

## PERFORMANCE

The auxiliary carrier option substantially increases load carrying and bending moments capacity over the standard single carrier models. As a general rule, the auxiliary carrier option is highly recommended in vertical applications ( $M_y$ ) if the distance from the carrier mounting surface to the load center of gravity (CG) exceeds the overall length of the carrier. Auxiliary carriers can be ordered with (DW) or without (DO) an internal piston. (Auxiliary carriers without a piston have no cushion on the cylinder end closest to the auxiliary carrier.)



NOTE: breakaway pressure will increase when using auxiliary carrier.

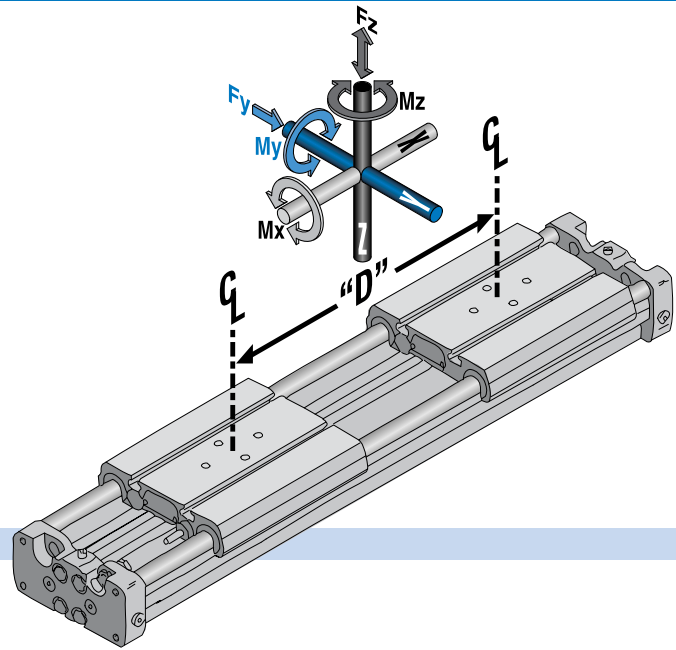

## BENDING MOMENTS

### LS10 AUXILIARY CARRIER LOAD vs DISTANCE

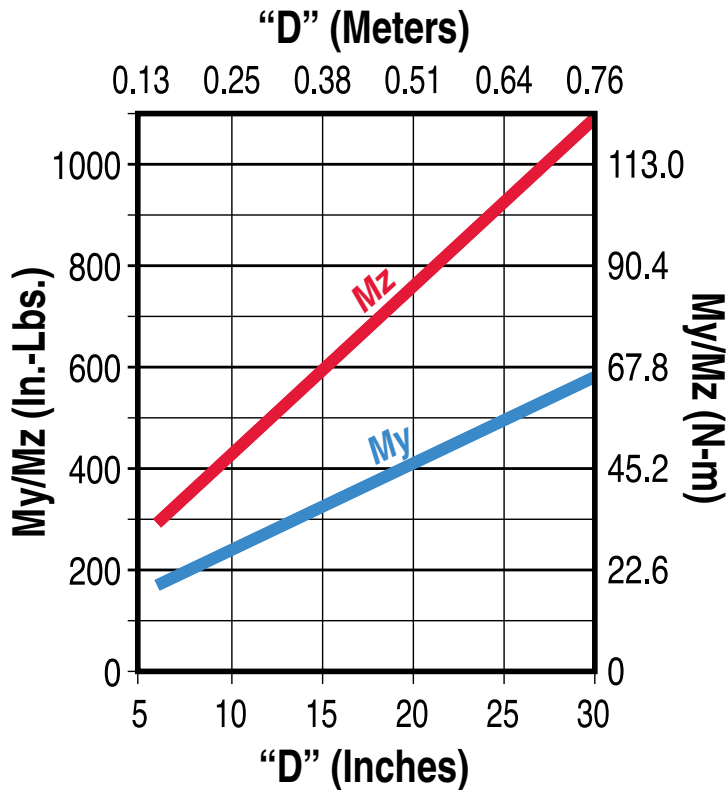

Rates were calculated with the following assumptions:

- 1.) Coupling between carriers is rigid.
- 2.) Load is equally distributed between carriers.
- 3.) Coupling device applies no misalignment loads to carriers.

	BORE SIZE		"D" MINIMUM *		MAX. BENDING MOMENT						MAX. LOAD	
					My**		Mx		Mz**		Fz	
	in	mm	in	mm	in-lbs	N-m	in-lbs	N-m	in-lbs	N-m	lbs	kg
<b>10</b>	1.00	25	5.75	146.1	177.80	20.09	160.00	18.08	277.80	31.30	200	90.8

\* "D" is distance between carriers

\*\* Loads calculated are at minimum "D", for substantially higher  $M_y$  and  $M_z$  loads increase "D" and refer to graph above

ABT  
MXP  
BC2  
BC3  
BC4  
LS  
MG  
CG  
PB  
ENGR

# LS Auxiliary Carrier - All Sizes

## AUXILIARY CARRIER

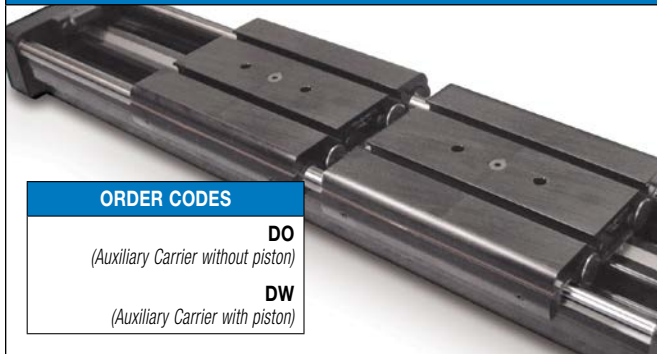

## ORDERING INFORMATION

When ordering, determine the minimum distance required between carriers (dimension "D" in Auxiliary Carrier Bending Moments chart).

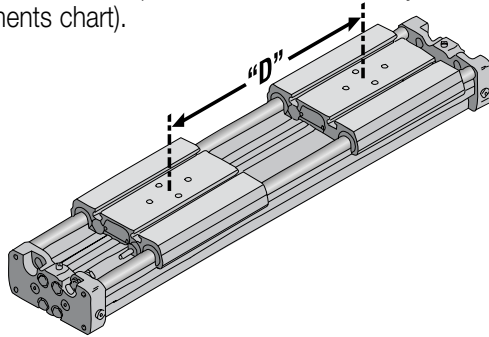

Determine your working stroke and your "D" dimension, then enter these into your configuration string. (Example: LS10SK30.00DW8.00RT2) The configurator will calculate the overall length of the actuator. Refer to page LS\_16 for complete LS ordering information.

## ASSEMBLY INFORMATION



### IMPORTANT INFORMATION REGARDING AUXILIARY CARRIER PLACEMENT

When an LS is ordered without shock absorbers, the auxiliary carrier is always placed to the left (while facing the switch mounted or open port side) of the main carrier.

When an LS is ordered with shock absorbers, the auxiliary carrier is always placed to the right (while facing the switch mounted or open port side) of the main carrier.

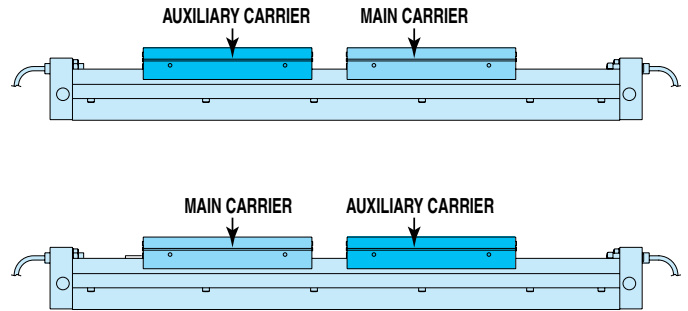

ABT

IMXP

BC2

BC3

BC4

LS

MG

CC

PB

ENGR

# LS Supports - All Sizes

## PERFORMANCE

### DISTANCE BETWEEN SUPPORTS

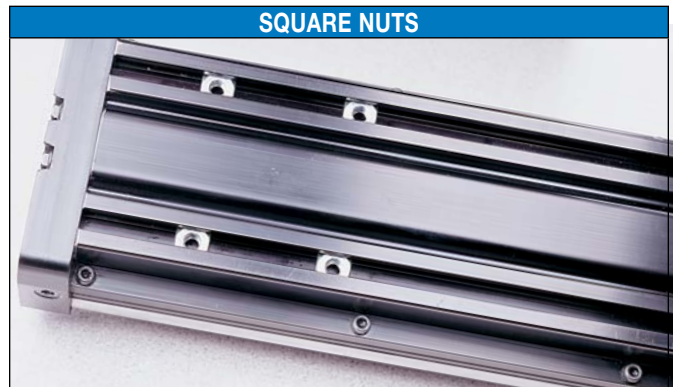
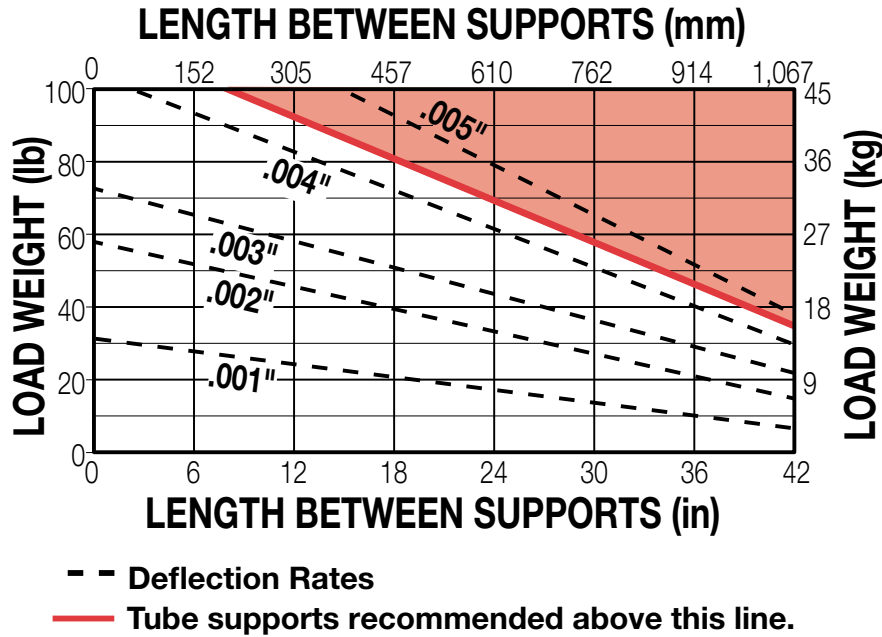

Base mounting linear slides may be accomplished by fastening directly to "T" slot nuts provided in the base of the slide (shown at right) or by using the MP mounting plates.

\*NOTE: Four square nuts are provided with each linear slide for base mounting. Additionally 2 square nuts are provided for 30" of stroke and 2 for every 20" of stroke thereafter.

## DIMENSIONS

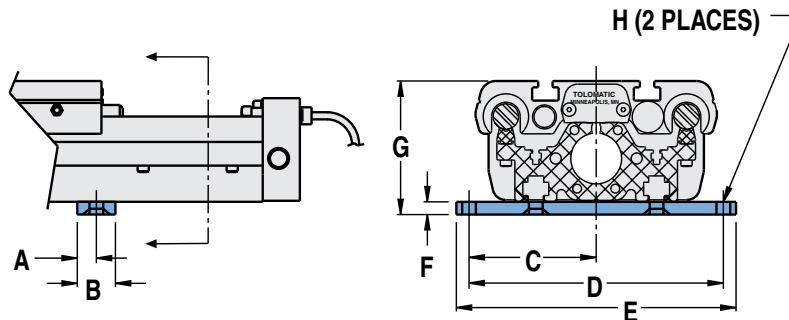

BORE SIZE	A	B	C	D	E	F	G	H Ø	
10	1.00	0.38	0.75	2.50	5.00	5.50	0.25	2.63	0.270

Dimensions in inches

BORE SIZE	A	B	C	D	E	F	G	H Ø	
10	25	9.7	19.1	63.5	127.0	139.7	6.4	66.8	6.86

Dimensions in millimeters



# LS Switches - All Sizes

## SWITCHES

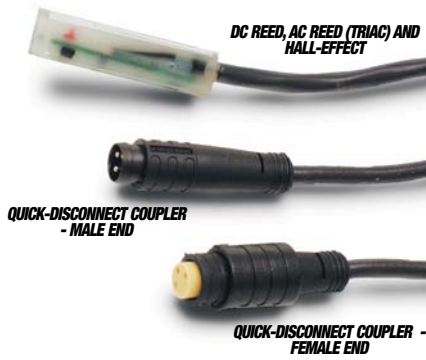

There are 10 sensing choices: DC reed, form A (open) or form C (open or closed); AC reed (Triac, open); Hall-effect, sourcing, PNP (open); Hall-effect, sinking, NPN (open); each with either flying leads or QD (quick disconnect). Commonly used to send analog signals to PLC (programmable logic controllers), TLL, CMOS circuit or other controller device. These switches are activated by the actuator's magnet.

Switches contain reverse polarity protection. QD cables are shielded; shield should be terminated at flying lead end.

If necessary to remove factory installed switches, be sure to reinstall on the same side of actuator with scored face of switch toward internal magnet.

## SPECIFICATIONS

ORDER CODE	REED DC				REED AC		HALL-EFFECT DC			
	R T	R M	B T	B M	C T	C M	T T	T M	K T	K M
LEAD	5m	QD*	5m	QD*	5m	QD*	5m	QD*	5m	QD*
CABLE SHIELDING	Unshielded	Shielded†	Unshielded	Shielded†	Unshielded	Shielded†	Unshielded	Shielded†	Unshielded	Shielded†
SWITCHING LOGIC	"A" Normally Open		"C" Normally Open or Closed		Triac Normally Open		PNP (Sourcing) Normally Open		NPN (Sinking) Normally Open	
MECHANICAL CONTACTS	Single-Pole Single-Throw		Single-Pole Double-Throw		Single-Pole Single-Throw		NO, These Are Solid State Components			
COIL DIRECT	Yes		Yes		Yes		—			
POWER LED	None		None		None		None		None	
SIGNAL LED	Red		None		None		Red		Red	
OPERATING VOLTAGE	200 Vdc max.		120 Vdc max.		120 Vac max.		5 - 25 Vdc			
OUTPUT RATING	—		—		—		25 Vdc, 200mA dc			
OPERATING TIME	0.6 msec max. (including bounce)		0.7 msec max. (including bounce)		—		< 10 micro sec.			
OPERATING TEMPERATURE	-40°F [-40°C] to 158°F [70°C]						0°F [-18°C] to 150°F [66°C]			
RELEASE TIME	1.0 msec. max.		—		—		—			
ON TRIP POINT	—		—		—		150 Gauss maximum			
OFF TRIP POINT	—		—		—		40 Gauss minimum			
**POWER RATING (WATTS)	10.0 §		3.0 §§		10.0		5.0			
VOLTAGE DROP	2.6 V typical at 100 mA		NA		—		—			
RESISTANCE	0.1 Ω Initial (Max.)		—		—		—			
CURRENT CONSUMPTION	—		—		1 Amp at 86°F [30°C] 0.5 Amp at 140°F [60°C]		200 mA at 25 Vdc			
FREQUENCY	—		—		47 - 63 Hz		—			
CABLE MIN. BEND RADIUS	STATIC		0.630" [16mm]							
	DYNAMIC		Not Recommended							

**CAUTION: DO NOT OVER TIGHTEN SWITCH HARDWARE WHEN INSTALLING!**

**\*\* WARNING:** Do not exceed power rating (Watt = Voltage X Amperage). Permanent damage to sensor will occur.

\*QD = Quick Disconnect; Male coupler is located 6" [152mm] from sensor, Female coupler to flying lead (part #2503-1025) distance is 197" [5m] also see Cable Shielding specification above

**REPLACEMENT OF QD SWITCHES MANUFACTURED BEFORE JULY 1, 1997:** It will be necessary to replace or rewire the female end coupler.

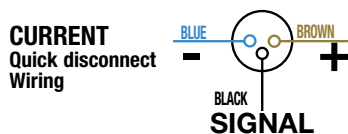

**Reed Switch Life Expectancy:** Up to 200,000,000 cycles (depending on load current, duty cycle and environmental conditions)

†Shielded from the female quick disconnect coupler to the flying leads. Shield should be terminated at flying lead end.

§ Maximum current 500mA (not to exceed 10VA) Refer to Temperature vs. Current graph and Voltage Derating graph

§§ Maximum current 250mA (not to exceed 3VA) Refer to Temperature vs. Current graph and Voltage Derating graph

# LS Switches - All Sizes

## PERFORMANCE

TEMP. vs CURRENT, DC REED

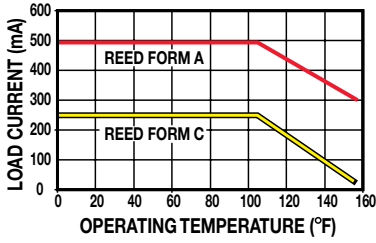

TEMP. vs CURRENT, AC REED

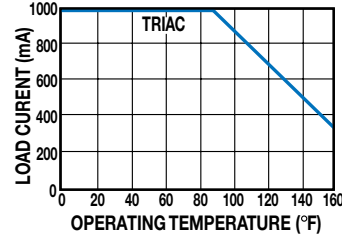

VOLTAGE DERATING, DC REED

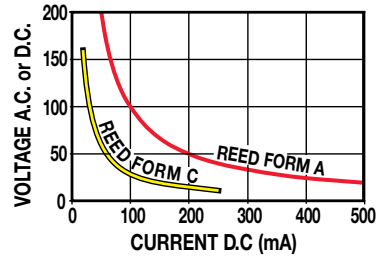

## WIRING DIAGRAMS

**R**T & **R**M DC REED, FORM A

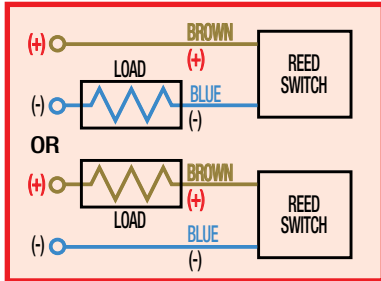

**C**T & **C**M AC REED, TRIAC

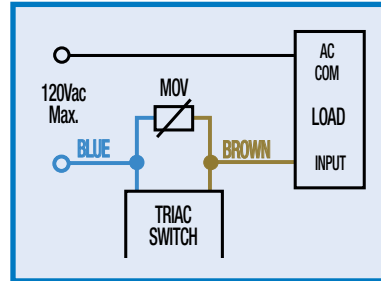

## INSTALLATION INFORMATION



**⚠** THE NOTCHED FACE OF THE SWITCH INDICATES THE SENSING SURFACE AND MUST FACE TOWARD THE MAGNET.

**B**T & **B**M DC REED, FORM C

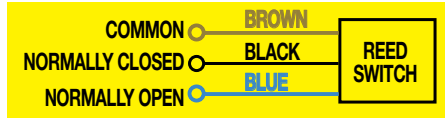

**T**T & **T**M HALL-EFFECT, SOURCING, PNP

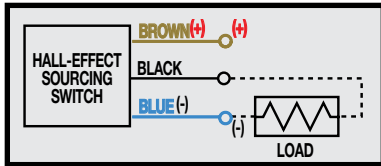

**K**T & **K**M HALL-EFFECT, SINKING, NPN

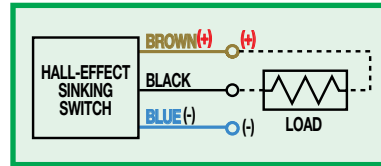

## DIMENSIONS

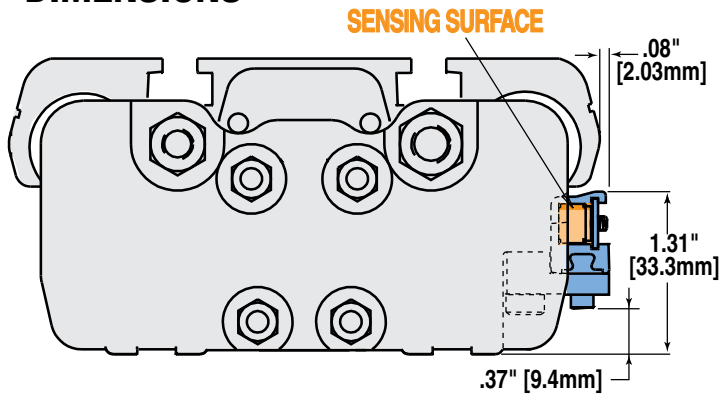

# LS Proximity Sensors - All Sizes

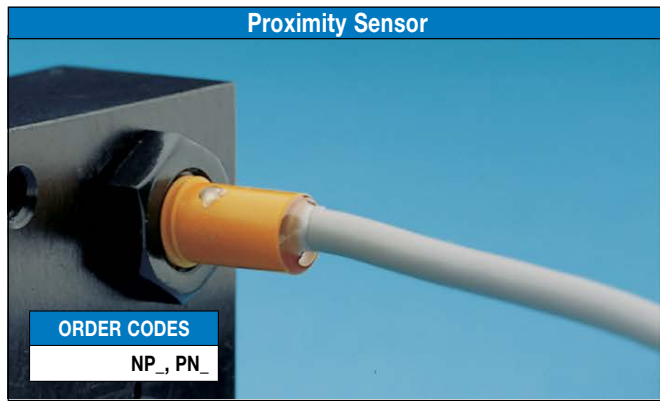

This L.E.D. device senses end-of-stroke with one of two normally open inductive d.c. proximity sensors. NPN supplies a sinking signal; PNP supplies a sourcing signal to a device such as a programmable logic controller.

Ambient Temp.: -13° to 158° F, (-25° to 70° C.)

NEMA Encl. Rating: 1, 3, 4, 6, 12, 13

Lead Length: 6.56 feet (2.0m)

Max. Sensing Distance (LS10): .039" (1.0mm)

## Wiring Diagrams

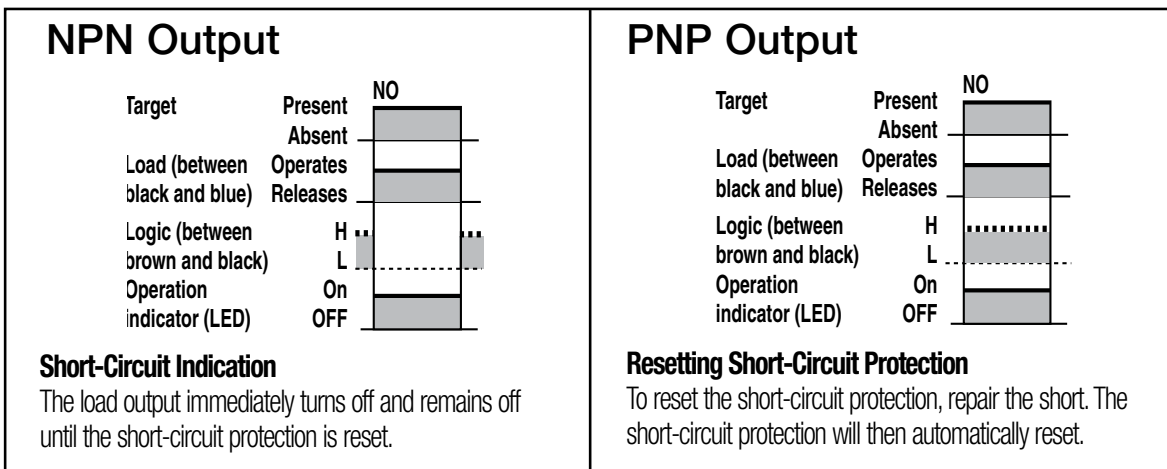
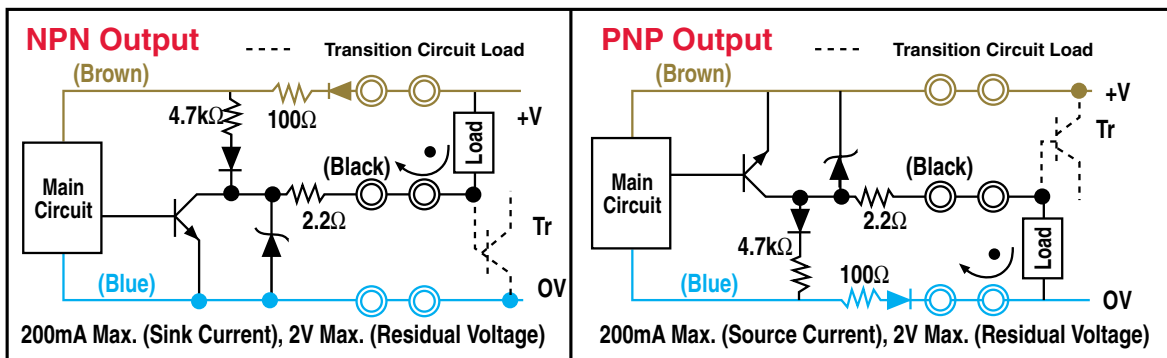

## DIMENSIONS

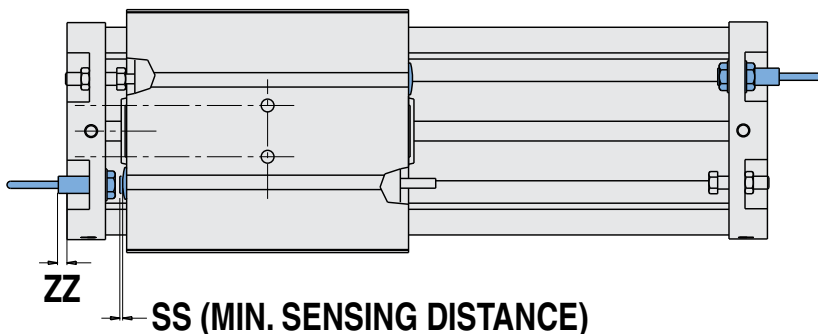

SIZE	BORE		SS		ZZ	
	in	mm	in	mm	in	mm
10	1.00	25.4	0.04	1.02	0.40	10.16

# LS Shock Absorbers - All Sizes

## SHOCK ABSORBERS



**ORDER CODE**  
**SH\_ or SL\_**  
 (\_ = Number ordered)

Rodless cylinders with standard internal cushion offer an effective method of decelerating loads. However, all Tolomatic rodless cylinders are capable of carrying heavier loads at higher velocities than the cylinder cushion can absorb. Optional shock absorbers can be used to increase the cylinder's life and broaden the application range for the cylinder model you have chosen.

Typical shock absorber life varies between 1-2 million cycles (depending on environment). Appropriate preventative maintenance should be considered in high cyclic applications.

**NOTE:** Actuators ordered without selecting a shock absorber MUST have external stops. The LS does NOT have internal bumpers or cushions.

**CAUTION:** In applications which result in a load bending moment at deceleration, care should be taken to decelerate the load rather than the carrier of the band cylinder.

## DIMENSIONS

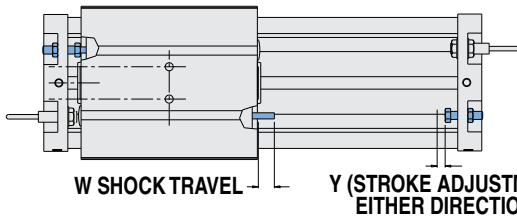

SIZE	BORE	W	Y
10	0.625	0.43	0.25

Dimensions in inches

SIZE	BORE	W	Y
10	25	10.9	6.4

Dimensions in millimeters

## PERFORMANCE

### VELOCITY vs LOAD

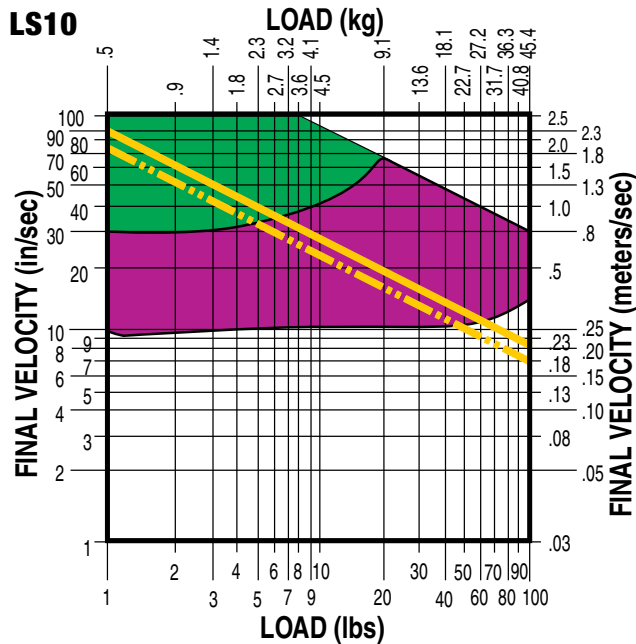

**LIGHT DUTY** (Light load/High velocity)

**HEAVY DUTY** (Heavy load/Low velocity)

# Application Data Worksheet

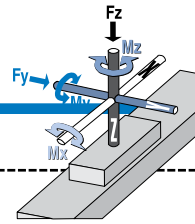

## STROKE LENGTH \_\_\_\_\_

- inch (S/K) (U.S. Standard)       millimeters (S/M) (Metric)

## AVAILABLE AIR PRESSURE \_\_\_\_\_

- PSI (U.S. Standard)       bar (Metric)

## REQUIRED THRUST FORCE \_\_\_\_\_

- lbf (U.S. Standard)       N (Metric)

## LOAD \_\_\_\_\_

- lb (U.S. Standard)       kg (Metric)

## LOAD CENTER OF GRAVITY DISTANCE TO CARRIER CENTER

- inch (U.S. Standard)       millimeters (Metric)

$d_x$  \_\_\_\_\_  
 $d_y$  \_\_\_\_\_  
 $d_z$  \_\_\_\_\_

## ORIENTATION

- Horizontal       Side       Horizontal Down

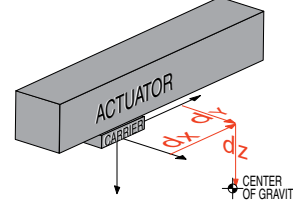
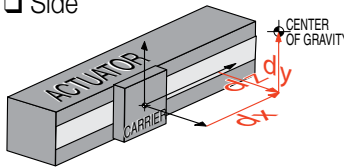
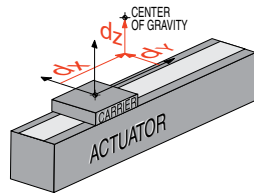

- Vertical

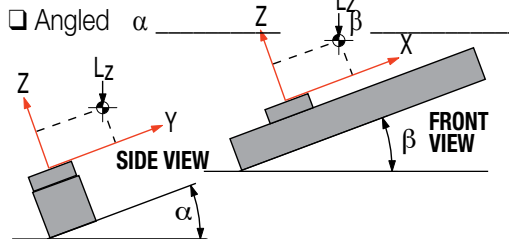
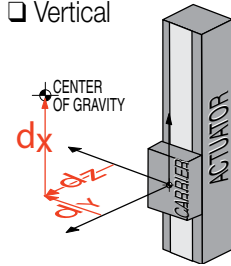

OTHER ISSUES:  
 (i.e. Environment,  
 Temperature,  
 Contamination, etc.)

Contact information: \_\_\_\_\_  
 \_\_\_\_\_  
 \_\_\_\_\_  
 \_\_\_\_\_

## FORCES APPLIED TO CARRIER

- lbf (U.S. Standard)       N (Metric)

$F_z$  \_\_\_\_\_  
 $F_y$  \_\_\_\_\_

## BENDING MOMENTS APPLIED TO CARRIER

- in-lbs (U.S. Standard)       N-m (Metric)

$M_x$  \_\_\_\_\_  
 $M_y$  \_\_\_\_\_  
 $M_z$  \_\_\_\_\_

## FINAL VELOCITY \_\_\_\_\_

- in/sec (U.S. Standard)       mm/sec (Metric)

## MOVE TIME sec. \_\_\_\_\_

## NO. OF CYCLES \_\_\_\_\_

- per minute       per hour



Fax (1-763-478-8080) or call Tolomatic (1-800-328-2174) with the above information. We will provide any assistance needed to determine the proper actuator.

# Rodless Cylinder Selection Guidelines - BC2, BC3, BC4, LS - All Sizes

## PROVIDING LOAD GUIDANCE AND SUPPORT

The process of selecting a load bearing actuator for a given application can be complex. It is highly recommended that you contact Tolomatic or a Tolomatic Distributor for assistance in selecting the best actuator for your application. The following overview of the selection guidelines are for educational purposes only.

### 1 COMPILE APPLICATION REQUIREMENTS

To determine the appropriate Band Cylinder or Linear Slide model for an application, compile the following information:

- Available pressure (PSI)
- Weight of load (lbs or kg)
- Orientation of load (lbs or kgs)
- Velocity of load (in/sec or mm/sec)
- Stroke length (in or mm)

HINT: Use Tolomatic sizing and selection software, download at: [tolomatic.com](http://tolomatic.com)

### 2 SELECT CYLINDER SIZE

- Consult the Theoretical Force vs. Pressure charts.
- Cross-reference the load force (or load weight if force is not known) and the available operating pressure. If the intersection falls below the diagonal line, and if moments do not exceed maximum values listed for that model (see Step 3), the actuator will accommodate the application.

If the intersection is above the diagonal line, a larger cylinder bore size should be considered.

NOTE: Additional force may be required to obtain the necessary acceleration for vertical or horizontal loads.

### 3 DETERMINE NATURE OF LOAD AND THE EFFECT OF BENDING MOMENTS

If the cylinder will guide and support a load located directly over the center of carrier, bending moments will not be a factor in the cylinder selection.

NOTE: The maximum load "L" must not exceed the capacity limits of the cylinder selected.

- Bending Moments

For off center or side loads, determine the distance from the center of mass of the load to the center of the carrier bracket. This measurement is needed to calculate the torque for bending moments. (Refer to Bending Moment chart for each model.)

Should the resulting maximum bending moment exceed figures indicated on the chart, external guides, auxiliary carrier/s or a larger cylinder should be considered.

- Auxiliary Carrier Bending Moments

The auxiliary carrier option (available on most models) increases load carrying capacity and bending moments. Auxiliary carriers can be ordered with or without an internal piston. (Auxiliary

carriers without a piston have no internal cushion on the cylinder end closest to the auxiliary carrier.)

IMPORTANT: When ordering, determine the working stroke, then the minimum distance required between carriers (dimension "D" in Auxiliary Carrier Bending Moments chart). When ordered, Tolomatic's configurator will calculate the overall length of the actuator.

NOTE: breakaway pressure will increase when using auxiliary carriers.

### 4 DETERMINE INTERNAL CUSHION CAPACITY

- Consult the Cushion Data chart for the model selected. The velocities listed on the cushion charts are final or cushion impact velocities. On applications where the internal cushions or bumpers are to be used, be sure the actual, final or impact velocity is known. If the velocity is not known, use of limit switches with valve deceleration circuits or shock absorbers should be considered. NOTE: The BC205 uses external bumpers in place of internal cushions, LS10 does not have cushions or bumpers.
- Cross-reference the final velocity and weight of the load. If the intersection is below the diagonal lines, the internal cushions on the actuator may be used. If the point falls above the dashed diagonal line or if the velocity is not known, use deceleration circuits, external shock absorbers or select a

larger cylinder with greater cushion capacity. On high-cyclic applications, use of external stops is strongly recommended.

### 5 DETERMINE TUBE SUPPORT REQUIREMENTS

- Consult the Tube Support chart for the model selected.
- Cross reference the load weight and maximum distance between supports.

### 6 CONSIDER OPTIONS

- Switches— dc Reed, Hall-effect or ac Triac

Band Cylinders and Linear Slides each have different standard features and options. Check the options section for the actuator you have selected.

- Shock Absorbers— if needed.
- Foot Mounting Kits
- Floating Mount Bracket – use when lack of parallelism occurs between the cylinder and an external guided and supported load.
- Single End Porting (BC3, BC4)
- Long Carrier (BC4)
- Proximity Sensors (LS)
- Dual 180° Carrier (BC3)

ABT  
MXP  
BC2  
BC3  
BC4  
LS  
MG  
CC  
PB  
ENGR



# LS Ordering - All Sizes

**MODEL, BORE, STROKE**      **OPTIONS**

**LS 10 NP SK 55 . 250**      **DW 6 . 0 MP 3 SH 2 BM 2**

**MODEL & MOUNTING**  
**LS** LS Linear Slide

**BORE SIZE**  
**10** 1.00" (25mm)

**MOUNTING & PORTS**

- NP** US standard mounting & NPT ports
- TP†** Metric mounting with metric taper ports
- GP†** Metric mounting with metric parallel ports

† The metric version provides metric tapped holes for mounting of the load to the carrier and of the actuator to mounting surfaces & metric ports

**STROKE LENGTH & MOUNTING TYPE**

**SK** \_\_\_ . \_\_\_ Stroke, enter desired stroke length in inches

**SM†** \_\_\_ . \_\_\_ Stroke, enter desired stroke length in millimeters

**NOTE:** Actuator mounting threads and mounting fasteners will be either inch or metric; depending on how stroke length is indicated.

**SK** = inch mounting  
**SM** = metric mounting

SIZE	MAXIMUM STROKE	
	...SK in	...SM mm
<b>10</b>	110	2,794

Not all codes listed are compatible with all options. Contact Tolomatic with any questions.

See page BC3\_25 for application guidelines

**AUXILIARY CARRIER (LS\_8)**

**DW** Auxiliary carrier With piston & "D" distance

**DO** Auxiliary carrier Without piston & "D" distance

\_\_\_ . \_\_\_ "D" Distance between carriers in inches (**SK**) or millimeters (**SM**)

**MINIMUM "D" DISTANCE BETWEEN CARRIERS**

	in	mm
<b>10</b>	5.17	131

\*When ordering auxiliary carrier option, enter the distance required between carriers. The configurator will calculate the overall length of the actuator.

**SUPPORTS (LS\_10)**

**MP** Support & number required

\*NOTE: Four square nuts are provided with each linear slide for base mounting. Additionally 2 square nuts are provided for 30" of stroke and 2 for every 20" of stroke thereafter.

**SHOCK ABSORBERS (LS\_14)**

**SH** Shock, Heavy duty and number required

**SL** Shock, Light duty and number required

\*NOTE: Actuators ordered without selecting a shock absorber MUST have external stops. The LS does NOT have internal bumpers or cushions.

**PROXIMITY SENSOR (LS\_13)**

**NP** Sinking type proximity sensor (NPN)

**PN** Sourcing type proximity sensor (PNP)

**SWITCHES (LS\_11)**

(Quantity desired follows ordering code)

- RM** Reed Switch (Form A) with 5-meter lead/QD (Quick-disconnect)
- RT** Reed Switch (Form A) with 5-m lead
- BM** Reed Switch (Form C) with 5-meter lead/QD
- BT** Reed Switch (Form C) with 5-m lead
- KM** Hall-effect Sinking Switch with 5-meter lead/QD
- KT** Hall-effect Sinking Switch w/ 5-m lead
- TM** Hall-effect Sourcing Switch with 5-meter lead/QD
- TT** Hall-effect Sourcing Switch with 5-meter lead
- CM** TRIAC Switch with 5-meter lead/QD
- CT** TRIAC Switch with 5-meter lead
- MDR** Dual Magnet (Reed, Hall-effect, Triac)

ABT

MXP

BC2

BC3

BC4

LS

MG

CC

PB

ENGR