

# SPRING-ACTUATED BRAKE FS-595 SERIES

Ductile Iron

**Models included:**

FS595DCIKQ	0781-0000
FS595DCIKQV	0781-0001
FS595DCIKE	0781-0011
FS595DCIKEV	0781-0012

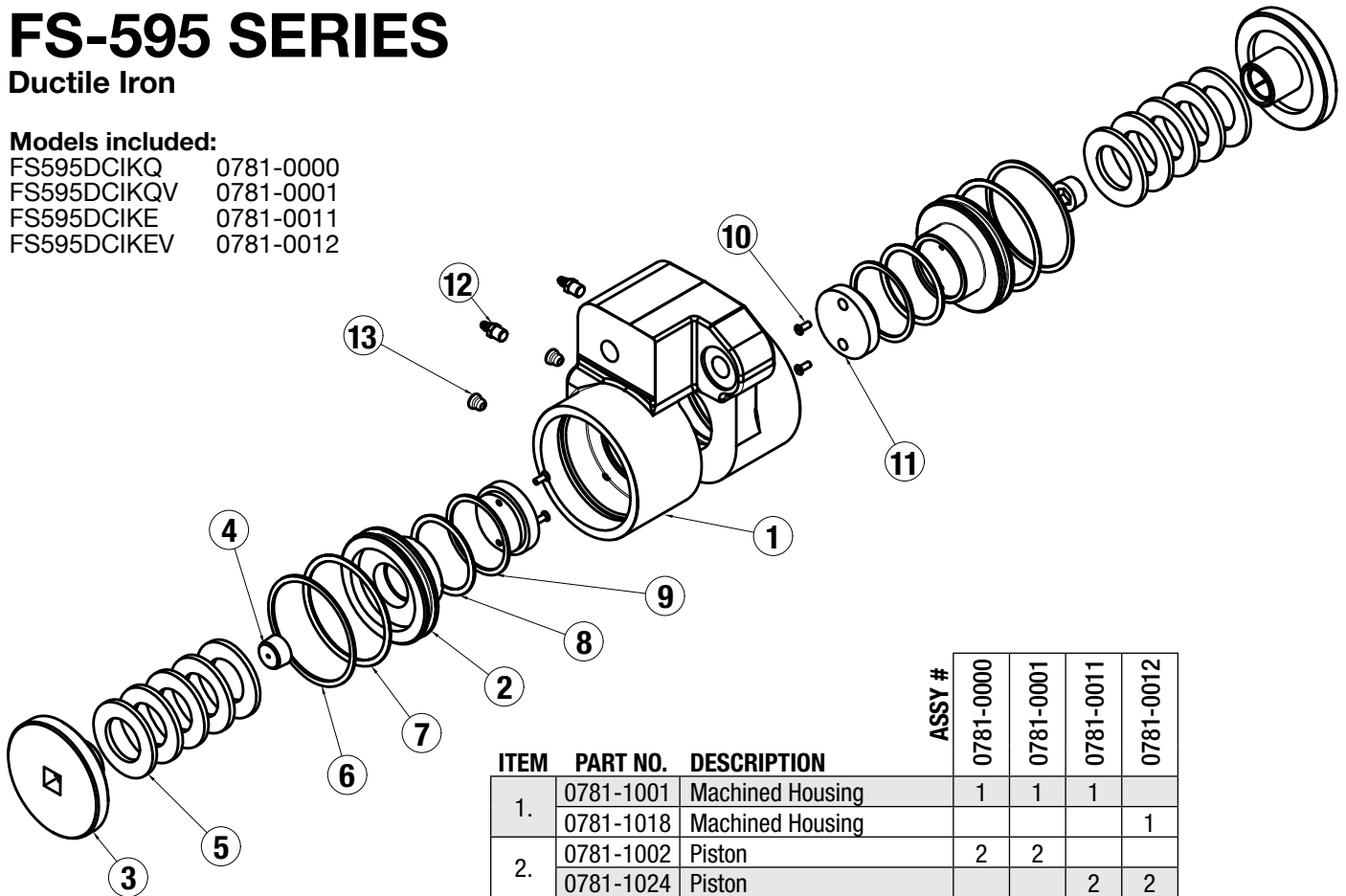

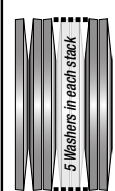

**DETAIL (#5): "B" BELLEVILLE SPRING WASHERS STACK**  
 NOTE: It is critical that the Belleville Spring Washers Stack is re-assembled as shown with washers opposing each other and no "nesting" of washers

ITEM	PART NO.	DESCRIPTION	ASSY #			
			0781-0000	0781-0001	0781-0011	0781-0012
1.	0781-1001	Machined Housing	1	1	1	
	0781-1018	Machined Housing				1
2.	0781-1002	Piston	2	2		
	0781-1024	Piston			2	2
3.	0781-1003	Compensator Cap	2	2	2	2
4.	0781-1016	Breather Plug	2	2	2	2
5.	0781-1004	Belleville Spring Washers	10	10	10	10
6.	0781-1007	Back-Up Ring, Buna-N	2		2	
	0781-1010	Back-Up Ring, TEFLON®		2		2
7.	1014-1083	O-Ring, Buna-N	2		2	
	1024-1063	O-Ring, VITON®		2		2
8.	1309-1012	O-Ring, Buna-N	2		2	
	0781-1013	O-Ring, VITON®		2		2
9.	0781-1005	Back-Up Ring, Buna-N	2		2	
	0781-1015	Back-Up Ring, TEFLON®		2		2
10.	0720-1009	Flat Head Screw	4	4	4	4
11.	0774-1006	Puck, Friction	2	2	2	2
12.	0740-1002	Bleeder Valve	2	2	2	2
13.	1001-1066	Vinyl Plug	2	2	2	2

**NOTE:** Items marked with capital letters are used only in models with those letter suffixes. Model number letter suffixes have the following meanings:

"C" indicates the brake has bleeder fittings.

"D" indicates the brake has double live sides.

"E" indicates the brake is designed to work with a 1/2" (12.7mm) thick disc.

"K" indicates the brake has a Manual Wear Compensator.

"Q" indicates the brake is designed for a 1 1/2" thick braking disc.

"V" indicates the brake is furnished with VITON® and Teflon® seals.

## INSTALLATION

**WARNING!** This brake unit is under SPRING TENSION.

Upon pressurization, **DO NOT** reduce or remove pressure without a disc or spacer of comparable thickness between the Pucks (#11).

1. When mounting the brake, connect the fluid pressure source to the Pressure Port on the Brake Housing (#1). Apply no more than 40 PSI (2.76 bar) of hydraulic pressure. Open the uppermost Bleeder Port (#12) to allow any trapped air to escape.
2. Repressurize the brake to 1,400 PSI (96.53 bar) and slip the brake over the disc and align the mounting in such a way that the Puck faces are parallel with the disc. The proper clearance between the Pucks and Disc is 0.020" to 0.030", when new.
3. To prevent excessive wear, be certain the disc does not rub against the housing or against the pucks when they are in the retracted position.
4. The disc must be free of dirt and grease to insure maximum braking action and life.
5. Do not pressurize the brake above 2,000 PSI (137.90 bar). Pressure fluctuations below 1,400 PSI (96.53 bar) will cause Puck drag.
6. As Spring-Applied, Hydraulically-Released Brakes wear, their torque output diminishes. For optimal performance the FS595 Brake must be adjusted for wear at least two times between every replacement of Brake Pucks (#11).

A Model FS595 Brake may be compensated without removing it from its mount. To compensate:

Remove the hydraulic pressure from the brake. Insert a 3/4" key stock or a 3/4" (19.05mm) socket extension into each Compensator Cap (#3). Turn both Compensator Caps clockwise one quarter turn. Reapply hydraulic pressure and measure the clearance between Pucks and disc. Repeat the procedure until a clearance of 0.030" between the Pucks and each side of the disc is reached. The brake has now been returned to its original rated release pressure and torque capacity.

## EMERGENCY PROCEDURES

1. The Model FS 595 Brake can be released without hydraulic pressure in an emergency situation where hydraulic pressure is lost and machinery or vehicle must still be moved.

2. Use a hydraulic hand pump to provide the needed pressure to release the brake. When doing this with a vehicle, make certain that the wheels are chocked to keep the vehicle in place once the brake is released.
3. If a hydraulic hand pump is not available and the machinery or vehicle must be moved, insert 3/4" by 3/4" key stocks or a 3/4" socket extensions into the Compensator Caps (#3) and turn counter-clockwise while simultaneously attempting to move the affected machinery.

**PRIOR TO HYDRAULIC PRESSURE BEING RESTORED, THE FS595 BRAKE MUST BE RETURNED TO ITS ORIGINAL OPERATING CONDITION BY TIGHTENING THE COMPENSATOR CAPS (#3) AND RESTORING CORRECT DISC CLEARANCE AS DESCRIBED PREVIOUSLY.**

## REPLACEMENT OF PUCKS AND PISTON SEALS

1. Insert two 3/4" by 3/4" key stocks or two 3/4" socket extensions into Compensator Caps (#3) and turn each cap counter-clockwise one-half turn at a time until disc is free to turn.
2. Remove the brake from its mounting.
3. Continue to unscrew the Compensator Caps at an equal rate until they are fully loosened. It is suggested that each Compensator Cap be turned one-half turn at a time, alternating between the two.
4. Remove the Compensator Caps and Belleville Springs (#5) from the Brake Housing (#1). Note the position of the Belleville Spring Washers in relationship to each other and the Piston (#2). Place the stacked Belleville Spring Washers aside with the piston side down for ease in reassembly.
5. Pushing from the puck side, slide the Piston (#2) out of its housing, taking care not to brush the seals against the threads of the Housing (#1). Examine seals for possible replacement.
6. Remove the Flat Head Screw (#10) and the Puck (#11) and install the new Puck. Coat the Flat Head Screw threads with Loctite® 242 and install.
7. Clean bores, pistons and grooves and grease O-Rings with a good O-Ring grease such as Lubriplate® 105.
8. Reverse the Disassembly procedure to rebuild the brake and then follow the installation instructions.

Loctite® is a registered trademark of the Loctite Corporation, [www.loctite.com](http://www.loctite.com)

Lubriplate® is a registered trademark of the Lubriplate Division of Fiske Brothers Refining Company, [www.lubriplate.com](http://www.lubriplate.com)

Teflon® and Viton® are registered trademarks of the E.I. Du Pont de Nemours Co., [www.dupont.com](http://www.dupont.com).

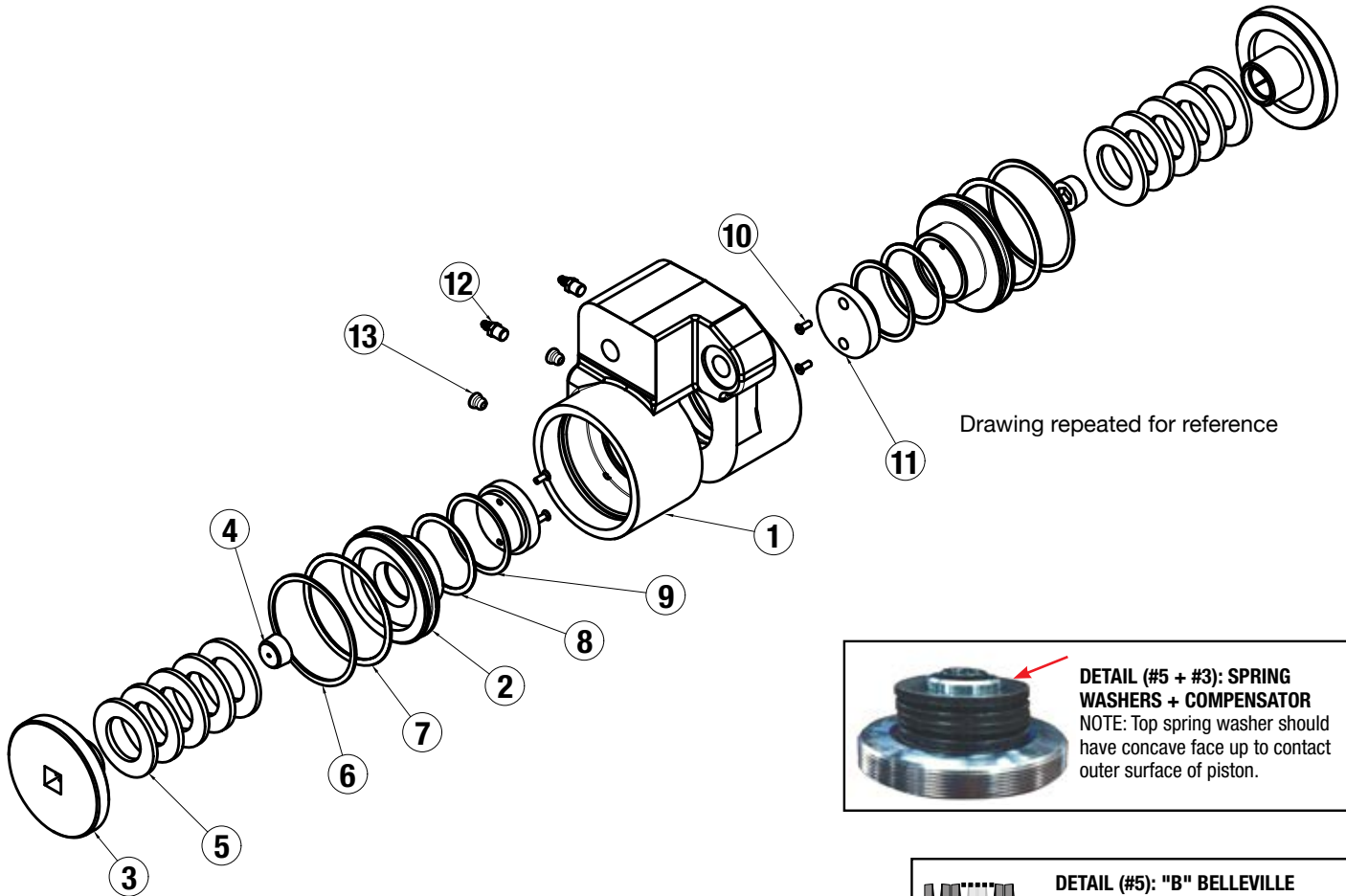

**FS595 ASSEMBLY INSTRUCTIONS**

1. Grease the smaller Back-Up Ring (#9) and O-Ring (#8) set with Lubriplate® 105. Insert the Back-Up Ring (#9) first, followed by the O-Ring (#8), into the inside groove of the Housing (#1).
2. Grease larger Back-Up Ring (#6) and O-Ring (#7) and install into the groove of Piston (#2). Back-Up Ring should be on the outside of the Piston, on the non-pressure side. The concave surface of the Backup Ring should mate with the O-Ring.
3. Align the holes of the brake Puck (#11) with the holes on the inner portion of the Piston (#2) and attach with 2 Flat Head Cap Screws (#10). Use Loctite® 242 thread locker if patch is not present.
4. Insert Piston (#2) into Housing (#1). Rock the Piston back and forth until the Piston reaches the bottom shoulder of the Housing.
5. Insert Breather Plug (#4) into the center of the Compensator Cap (#3). Screw the Breather Plug in until it is finger tight, then with a wrench tighten 1/2 turn more.

6. Place a stack of 5 Spring Washers (#5) over of the Compensator Cap (#3). The top Spring Washer should have the outside diameter its highest point to contact the piston.
7. Insert the Compensator Cap (#3) and Spring Washer Assembly (#5) into the Housing (#1) and screw all the way down, torque to 20 in-lbs (2.26 Nm).
8. Repeat Steps 1 - 7 to complete the opposite side of the Housing (#1).
9. Apply Loctite® 242 Thread Locker to two of the tapped holes in the Housing (#1) and install Bleeder Valves (#12).
10. Test for release pressure. Release pressure is the lowest pressure at which the disc can be removed from the brake pucks without interference. While unit is at the nominal release pressure, check for visible fluid leaks and/or pressure loss.



3800 County Road 116, Hamel, MN 55340  
 http://www.Tolomatic.com • Email: Help@Tolomatic.com  
 Phone: (763) 478-8000 • Fax: (763) 478-8080 • Toll Free: 1-800-328-2174



Information furnished is believed to be accurate and reliable. However, Tolomatic assumes no responsibility for its use or for any errors that may appear in this document. Tolomatic reserves the right to change the design or operation of the equipment described herein and any associated motion products without notice. Information in this document is subject to change without notice.