



2-1/2" Band Cylinder® (Metric)

BCM100-250P (Multi-ported, parallel head) 4925-0001

BCMM100-250P (Multi-ported, tapered head) 5925-0001

Discontinued Product
Style or Size. Parts
Sheet is for use only
with Repair Kits

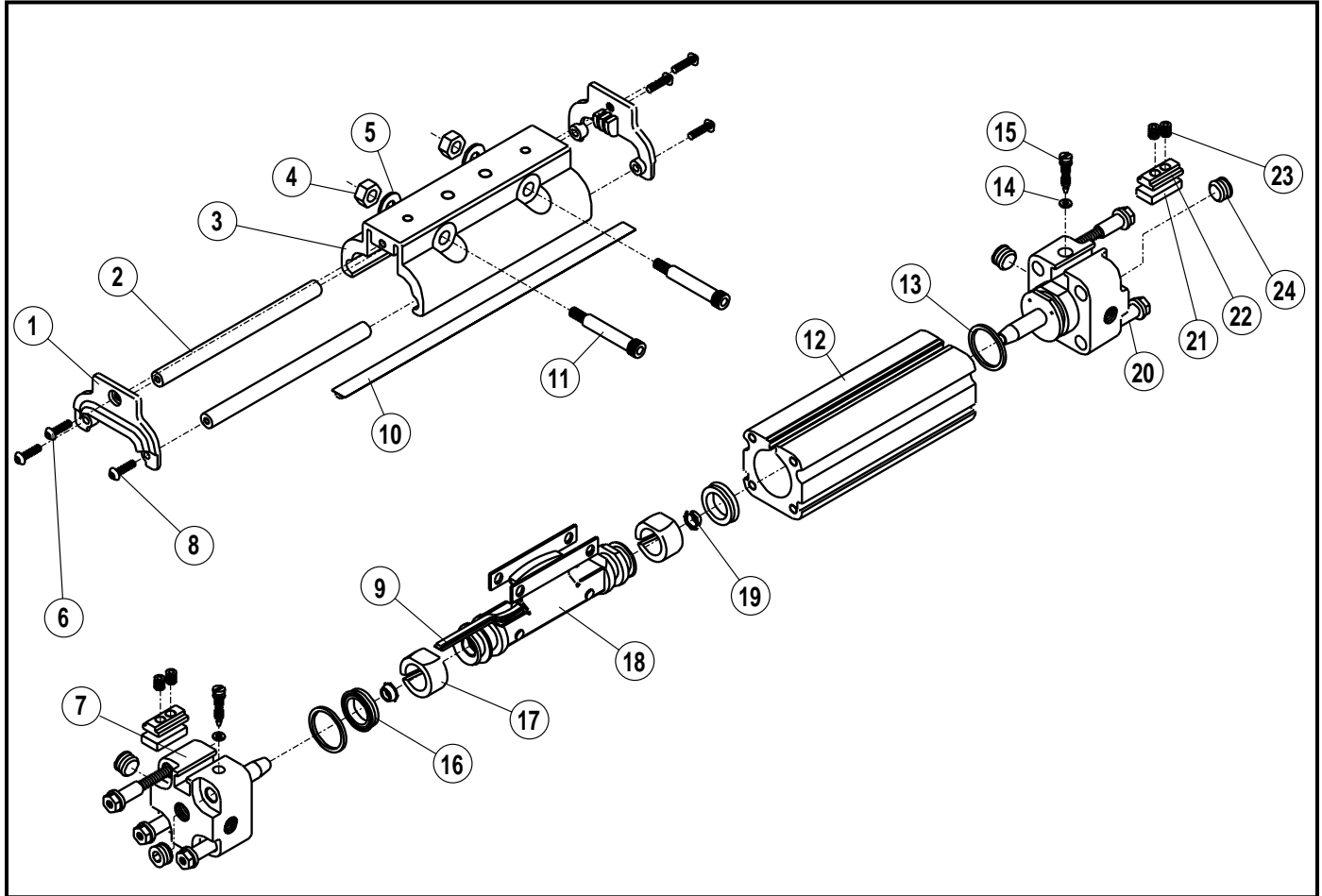

List of Parts

ITEM	PART NO.	DESCRIPTION	QUANTITY	ITEM	PART NO.	DESCRIPTION	QUANTITY
1.*	0925-1008	Carrier End Cap	2	13.*	0774-1007	O-Ring	2
2.*	4925-1018	Bearing Rod	2	14.*,**	0720-1003	O-Ring	2
3.	4925-1003	Carrier Bracket	1	15.*,**	0925-1015	Cushion Needle	2
4.	4920-1014	Self-Locking Nut	2	16.*	0925-1027	U-Cup	2
5.	0925-9001	Washer	2	17.*	0925-1020	Wear Ring	2
6.	4920-1025	Button Head Screw	2	18.	4925-9004	Piston Bracket Assembly	1
7.	4525-9021	Head Assy., Multi-port, Tapered	2	19.*	0925-1012	Cushion Seal	2
	5525-9011	Head Assy., Multi-port, Parallel	2	20.	4925-1047	Tapped Screw	8
8.	4925-1032	Button Head Screw	4	21.	0925-1026	Band Wedge	2
9.*	0925-9001	Sealing Band (specify stroke)	1	22.**	4925-1034	Band Cover	2
10.*	4925-9002	Dust Band (specify stroke)	1	23.**	4915-1044	Set Screw	4
11.	4925-1051	Socket Head Shoulder Screw	2	24.**	4920-1029	Pipe Plug, Tapered	4
12.	4925-1001	Cylinder Tube (specify stroke)	1		5920-1004	Pipe Plug, Parallel	2

*Included in Repair Kit 4925-9033.

** Included in Head Assemblies, 4525-9021 and 5525-9011.

For models manufactured prior to November 15, 1991, please refer to part sheet 0910-0229.

Model BCM100-250 and BCMM100-250

Maintenance, Assembly and Disassembly Instructions

MAINTENANCE

1. The Band Cylinder should be kept as clean as possible around the bands and Carrier Bracket.
2. Always use air that is adequately lubricated. Tol-O-Matic recommends that a 5 to 10 weight non-detergent, petroleum oil be used. For FDA requirements, we recommend that Multitherm® PG-1 or equivalent be used. For dry air applications, please consult Tol-O-Matic, Inc., toll free at 1-800-328-2174.

CARRIER BRACKET ADJUSTMENT

The tracking tension on the Carrier Bracket may be adjusted by tightening or loosening the two screws and nuts on the bracket. To tighten or loosen the bolts, use a socket and ratchet wrench and an Allen wrench.

CAUTION: Make certain not to overtighten the Carrier Bracket adjustment screws. It is possible to tighten them enough to keep the Carrier and Piston from moving. Tightening the Carrier Bracket directly affects the cylinder's breakaway. In other words, the tighter the adjustment the higher the breakaway.

DISASSEMBLY

1. Remove Band Cylinder from machinery.
2. Loosen two (2) Set Screws (#23) and remove Band Wedge (#21).
3. Remove the four (4) Tapped Screws (#20) to free Cylinder Head Assemblies (#7).
4. Remove three (3) Button Head Screws (#6, #8) and Screw (#11) to free the Carrier Bracket (#3), End Caps (#1) and Bearing Rods (#2).
5. Slide Piston and Bracket Assembly (#18) to end of tube.
6. Remove Top Dust Band (#10) by lifting one end and drawing it back across the entire length of the cylinder.
7. Remove the Inner Sealing Band (#9) by passing a screwdriver or similar tool through the slot in the cylinder tube to dislodge the band from the tube. (Take care in doing this step to make certain that NO SCRATCHES ARE MADE in the tube bore or slot).

ASSEMBLY

1. Thoroughly clean all components, particularly the tube bore slot and bands. CAREFULLY LUBRICATE THE TUBE AND ALL RUBBER PARTS INCLUDING THE RUBBER ON BOTH THE INSIDE AND OUTSIDE BAND WITH MAGNALUBE® GREASE. NOTE: Not SAE grade 30 weight non-detergent oil.
2. Insert new Inner Sealing Band (#9) into the cylinder tube (with the rubber portion facing up into the slot), centering the band along its entire length.

CAUTION: The metal edges of the band are very sharp. Exercise caution to avoid injury either to yourself or the band and tube when inserting both the inner and outer bands.

3. Insert the Piston and Bracket Assembly (#18), with new U-Cups (#16), Cushion Seals (#19) and Wear Ring (#17) in place, into the tube, passing the Inner Sealing Band through the Piston and Bracket Assembly.
4. Push the Piston (#18) along the cylinder tube to force the Inner Sealing Band into the sealing position.
5. Install the Top Dust Band (#10) with the rubber sealing portion facing down into the slot and centering the band along its entire length. While doing this, make certain to thread the band through the Piston and Bracket Assembly.
6. Install the Carrier Bracket (#3), Bearing Rods (#2) and End Caps (#1) using screws (#6, #8) and (#4, #11) using OmniFIT® #1730 on the Button Head Screws (#6, #8).
7. Adjust clearance between the Carrier Bracket (#3) and the Cylinder Tube (#12) by tightening the two Locknuts (#4) evenly to the desired tension.
8. Install the Cylinder Head Assemblies (#7) with new O-Rings (#13) in place and tighten the four (4) Tapped Screws (#20) to hold each end in place.
9. Install the Band Wedge (#21) in each Head Assembly by inserting the narrowest part of the wedge towards the cylinder between the Inner Sealing Band (#9) and the Top Dust Band (#10). Then tighten the two (2) Set Screws (#23) to lock the Band Wedge in place.
10. Run the Carrier Bracket back and forth along the full stroke to make certain that the cylinder is properly assembled before applying air.
11. Remount the cylinder on the machinery it was taken from.



TOL-O-MATIC, INC.

3800 County Road 116, Hamel, MN 55340

<http://www.Tolomatic.com> • Email: Help@Tolomatic.com

Phone: (763) 478-8000 • Fax: (763) 478-8080 • Toll Free: 1-800-328-2174



Information furnished is believed to be accurate and reliable. However, Tol-O-Matic assumes no responsibility for its use or for any errors that may appear in this document. Tol-O-Matic reserves the right to change the design or operation of the equipment described herein and any associated motion products without notice. Information in this document is subject to change without notice.