

ERD Rod-Style Actuators

Models:

ERD10, ERD15, ERD20

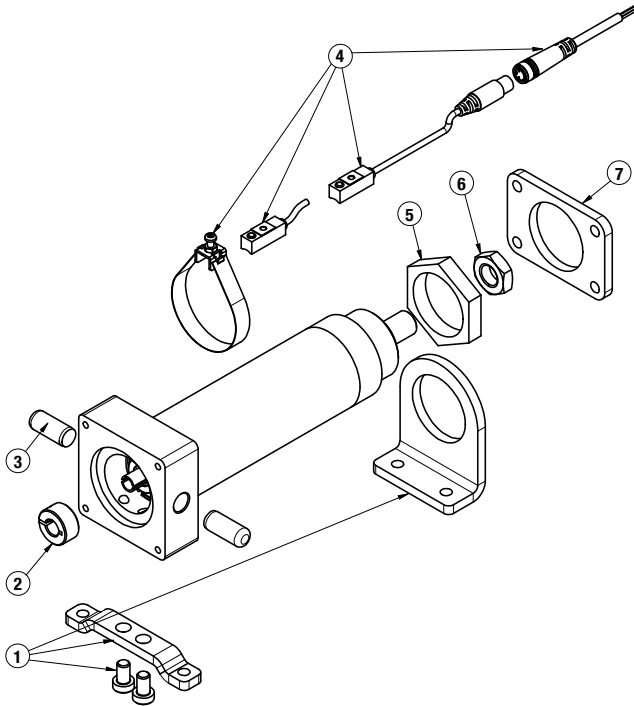

(1-16-2020) ERD06 IS A DISCONTINUED PRODUCT SIZE. PARTS SHEET IS FOR REPAIR INSTRUCTIONS ONLY.

Parts listing is for reference only. All parts listed for the ERD06 are limited to stock on hand. Contact Tolomatic regarding availability.

NOTE



The ERD actuator is not field repairable, this parts sheet is for external components and options.

NOTE!

Before starting any maintenance activities, make sure that the supply power is shut OFF.

Parts Listing

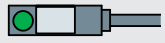
ITEM	PART NO or CONFIG CODE	DESCRIPTION	ERD10	ERD15	ERD20	ERD06 Discont.
1.	2191-9001	FOOT MOUNT KIT	1			
		2191-1021 Nose Bracket	1			
		2191-1022 Foot Bracket	1			
		2192-1011 Low Head Cap Screw	2			
		2192-9001 FOOT MOUNT KIT		1		
		2192-1021 Nose Bracket		1		
		2192-1022 Foot Bracket		1		
		2193-1010 Hex Bolt		2		
		2192-9203 FOOT MOUNT KIT for SS2 Option		1		
		2192-1021 Nose Bracket		1		
		2192-1214 Gasket		1		
		2192-1222 Foot Bracket for SS2 Option		1		
2.	2191-1011	Collar Clamp	1		NA	
	3417-1437	Collar Clamp		1	NA	
	0610-1044	Trunnion Pin	2			
3.	6000-1785	Trunnion Pin		2		
	2193-1018	Trunnion Pin			2	
	SWITCHES WITHOUT QUICK-DISCONNECT COUPLERS					
4.	SWERD_RY	Reed, SPST Normally Open	A/R	A/R	A/R	A/R
	SWERD_TY	Solid State, PNP (sourcing) Normally Open	A/R	A/R	A/R	A/R
	SWERD_KY	Solid State, NPN (sinking) Normally Open	A/R	A/R	A/R	A/R
	SWITCHES WITH QUICK-DISCONNECT COUPLERS					
5.	SWERD_RK	Reed, SPST Normally Open	A/R	A/R	A/R	A/R
	SWERD_TK	Solid State, PNP (sourcing) Normally Open	A/R	A/R	A/R	A/R
	SWERD_KK	Solid State, NPN (sinking) Normally Open	A/R	A/R	A/R	A/R
6.	2191-1020	Hex Mounting Nut	1			
	2192-1020	Hex Mounting Nut		1		
	2193-1020	Hex Mounting Nut			1	
7.	2191-1023	Hex Jam Nut	1			
	2192-1023	Hex Jam Nut		1		
	2193-1023	Hex Jam Nut			1	
1.	2191-1025	Flange	1			
	2192-1025	Flange		1		
	2193-1025	Flange			1	
1.	2190-9001	FOOT MOUNT KIT				1
		2190-1021 Nose Bracket				1
		2190-1022 Foot Bracket				1
		8125-1075 Low Head Cap Screw				2
2.	2191-1011	Collar Clamp				1
3.	1820-1003	Trunnion Pin				2
5.	2190-1020	Hex Mounting Nut				1
6.	2190-1023	Hex Jam Nut				1
7.	2190-1025	Flange				1

	Order Code	Lead	Switching Logic	Power LED	Signal LED	Operating Voltage	**Power Rating (Watts)	Switching Current (mA max.)	Current Consumption	Voltage Drop	Leakage Current	Temp. Range	Shock / Vibration
REED	RY	5m	SPST Normally Open	—	Red	5 - 240 AC/DC	**10.0	100mA	—	3.0 V max.	—	14 to 158°F	30 G / 9 G
	RK	QD*											
SOLID STATE	TY	5m	PNP (Sourcing) Normally Open	—	Green	5 - 30 VDC	**3.0	200mA	8 mA @ 24V	1.0 V max.	0.01 mA max.	[-10 to 70°C]	50 G / 9 G
	TK	QD*											
	KY	5m	NPN (Sinking) Normally Open	—	Red								
	KK	QD*											

(1-16-2020)
ERD06 IS A DISCONTINUED PRODUCT SIZE. PARTS SHEET IS FOR REPAIR INSTRUCTIONS ONLY.
Parts listing is for reference only. All parts listed for the ERD06 are limited to stock on hand. Contact Tolomatic regarding availability.

*QD = Quick-disconnect Enclosure classification IEC 529 IP67 (NEMA 6) CABLES: Robotic grade, oil resistant polyurethane jacket, PVC insulation

▲**WARNING: Do not exceed power rating (Watt = Voltage x Amperage). Permanent damage to sensor will occur.

WIRING DIAGRAMS

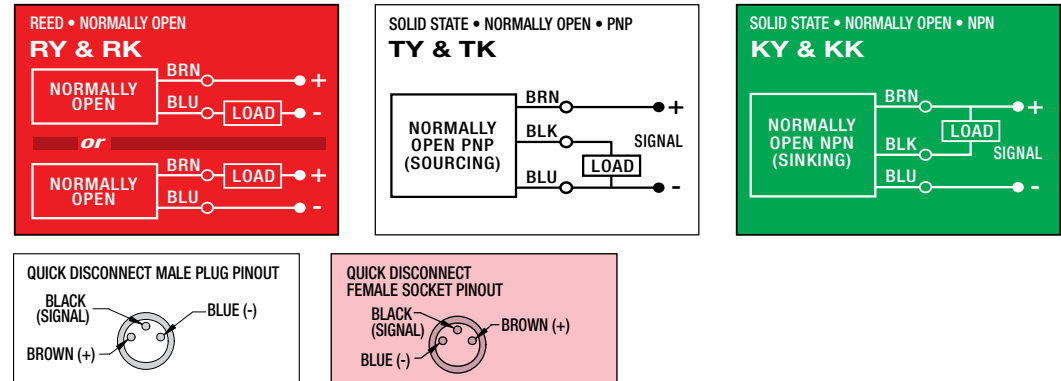

SWITCH INSTALLATION - FIELD REPLACEMENT INSTRUCTIONS

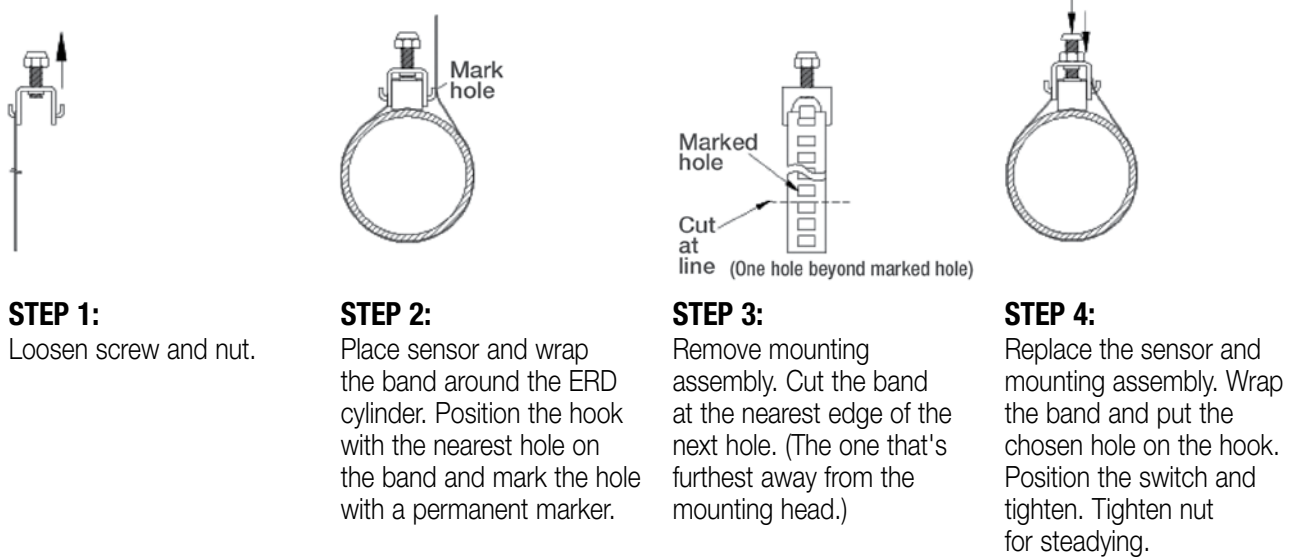

(1-16-2020) ERD06 IS A DISCONTINUED PRODUCT SIZE. PARTS SHEET IS FOR REPAIR INSTRUCTIONS ONLY.

Parts listing is for reference only. All parts listed for the ERD06 are limited to stock on hand. Contact Tolomatic regarding availability.

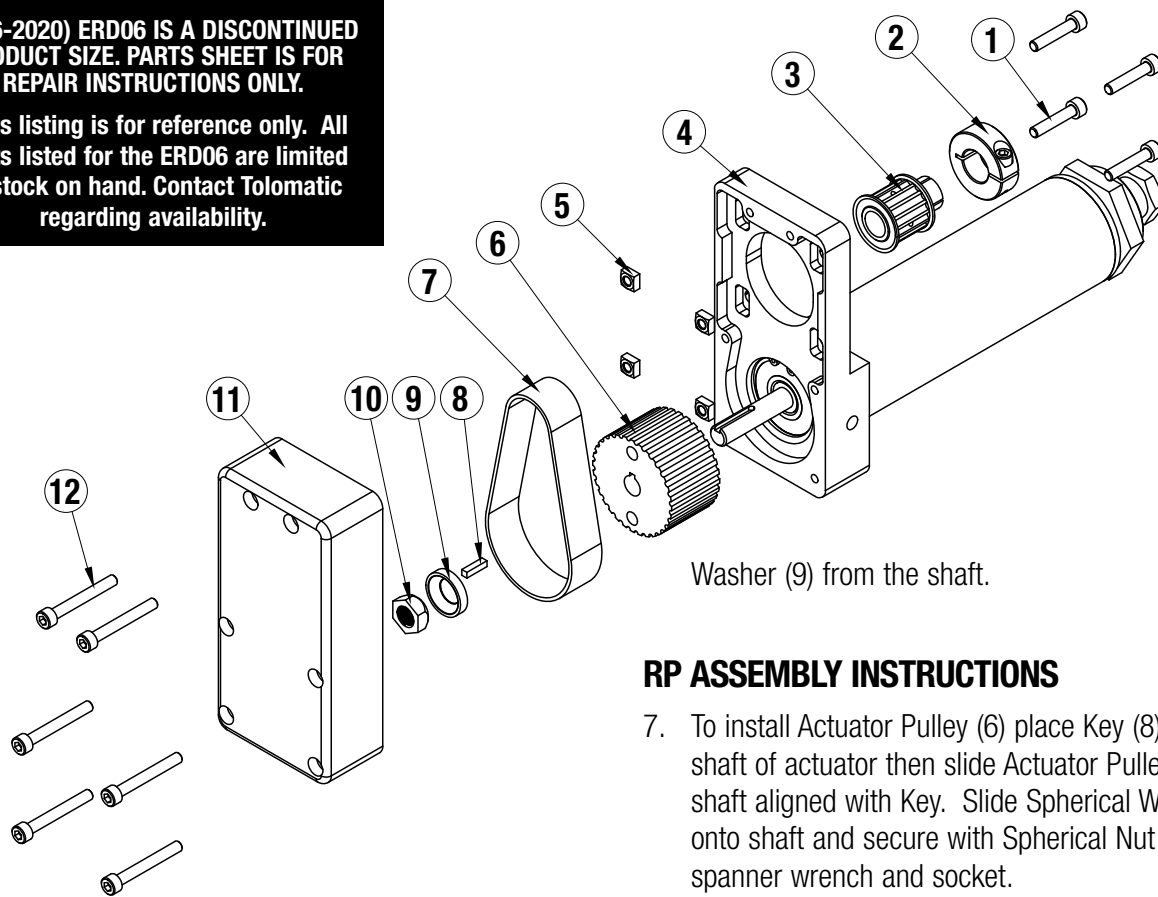

Washer (9) from the shaft.

RP DISASSEMBLY INSTRUCTIONS (ERD15 & 20)

Begin with a clean work area. Be sure all replacement parts are present and have no visual damage or defects. The following tools are recommended for proper disassembly and assembly.

Allen wrench set

Socket wrench & socket set

1. Loosen the Motor Mount Fasteners (1) to remove belt tension.
2. Remove RP Cover (11) by removing the six Socket Head Cap Screws (12).
3. Remove Belt (7).
4. Remove the motor by removing the Motor Mount Fasteners (1) and the Square Nuts (5).
5. To replace motor, remove Motor Pulley (3) by loosening Collar Clamp (2) and sliding both off motor shaft.
6. To replace Actuator Pulley (6) use spanner wrench on Actuator Pulley and socket to remove Spherical Nut (10). Pull Actuator Pulley, Key (8) and Spherical

RP ASSEMBLY INSTRUCTIONS

7. To install Actuator Pulley (6) place Key (8) onto shaft of actuator then slide Actuator Pulley onto the shaft aligned with Key. Slide Spherical Washer (9) onto shaft and secure with Spherical Nut (10) using spanner wrench and socket.
8. Align motor with slots RP Plate (4). Install four Motor Mount Fasteners (1) through motor and RP Plate then into the four Square Nuts (5). The Square Nuts must seat into the pockets of the RP Plate. Tighten enough so motor is not drooping but able to move vertically.
9. Align the Collar Clamp (2) with the Motor Pulley (3) and install the Motor Pulley onto the motor shaft by tightening the Collar Clamp fastener. Align Motor Pulley with the Actuator Pulley (6).
10. Slide Belt (7) over Motor Pulley (3) and Actuator Pulley (6).
11. Attach RP Cover (11) to RP Plate (4) using six Socket Head Cap Screws (12).
12. Tension the Belt (7) by pulling the motor away from the leadscrew with the appropriate force in the chart below. Tighten the Motor Fasteners (1) while this force is applied to the motor.

Motor Shaft Diameter	Tension Force
< 0.375	10 lbs
>=.375 < .625	20 lbs
>=.625	30 lbs

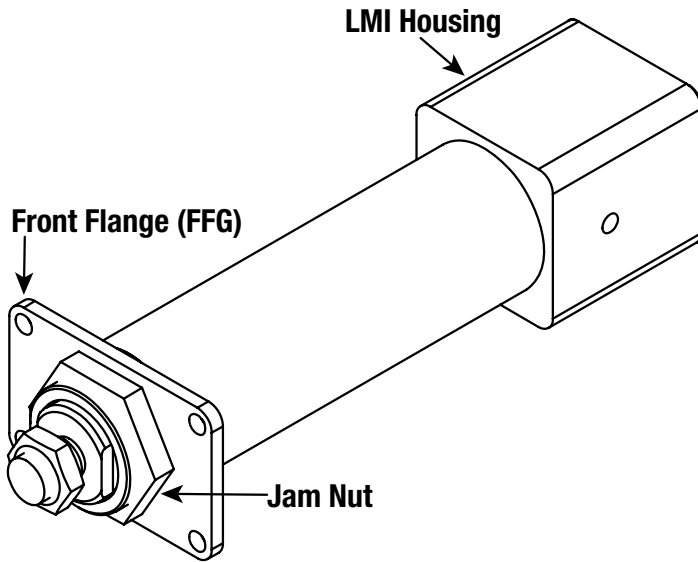

FRONT FLANGE OPTION (FFG)

1. Secure Front Flange onto the Nose Bushing using Front Jam Nut or Wiper Cap.
 - 1.1. Lightly clamp unit at LMI/RP Housing with wood or plastic jaws.
 - 1.2. Torque Jam nut or Wiper Cap using the socket or crow's foot to the specified torque listed in the table below.

ERD SIZE	SOCKET/CROW'S FOOT SIZE	INSTALL TORQUE	
		(in-lbs)	(N-m)
10	30 mm	60	6.8
15	36 mm	80	9.0
20	48mm	180	20.3

COLLAR CLAMP MOUNTING (ERD10 & 15)

- Slide collar clamp onto leadscrew. Slots in collar clamp should align with slots in leadscrew.
- Place correct sized Hex Key into the through hole in rear housing and lock into fastener as shown in Photo 1.1.
- Slide motor shaft into leadscrew shaft with desired orientation.

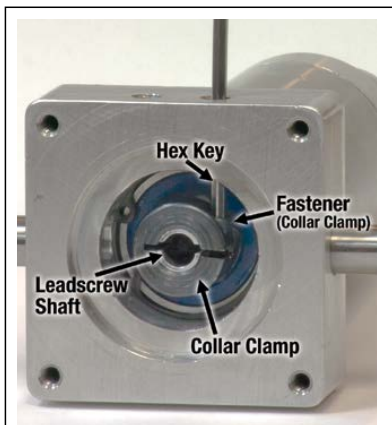

Photo 1.1

- Install motor fasteners but leave a bit loose to allow for alignment of motor fastening screws.
- While holding motor flush to ERD rear housing, tighten collar clamp to the specifications found in Table 1.1.
- Tighten motor fastening screws.

Table 1.1

ERD SIZE	COLLAR CLAMP SCREW SIZE	HEX KEY SIZE	INSTALLATION TORQUE	
			(In-lbs)	(N-m)
10	M3	2.5 mm	19	2.15
15				
06 Discont.	M3	2.5 mm	19	2.15

COUPLER MOUNTING (ERD10, 15 & 20)

- Slide actuator side coupler half onto leadscrew.
- Place correct sized Hex Key into the through hole in rear housing and lock into fastener as shown in Photo 2.1.
- End of leadscrew should be flush or below the face of the coupler. Tighten each fastener in the coupler evenly and to the specs listed in table 2.1. When tightened, the gap between the coupler half and the rear housing should be equal all around. (see photo 2.2)

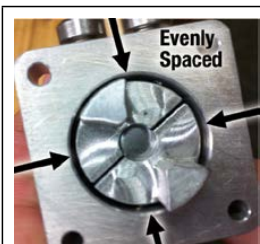

Photo 2.2

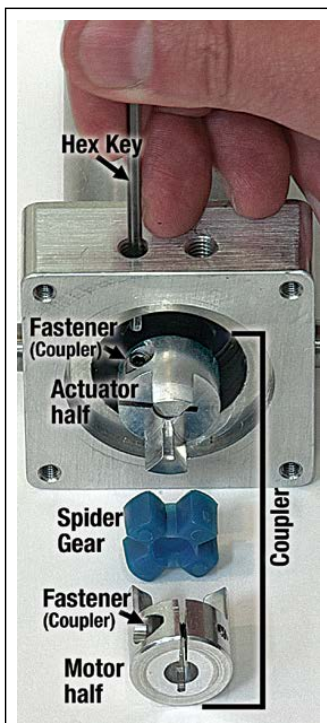

Photo 2.1

- Install spider gear onto the actuator side coupler half and install the motor spacer to the rear housing of the ERD.
- Install second half of coupler onto the motor shaft; keeping the face of

coupler flush with end of shaft.

Tighten in same manner and to same specs as actuator side coupler half.

- Place motor onto the motor spacer and align coupler to spider gear. Tighten motor fastening screws.

Table 2.1

ERD SIZE	CROSS BOLT SIZE	HEX KEY SIZE	INSTALLATION TORQUE	
			(In-lbs)	(N-m)
10	M3	2.5 mm	13	1.47
15				
20	M4	3.0 mm	40	4.52

(1-16-2020) ERD06 IS A DISCONTINUED PRODUCT SIZE. PARTS SHEET IS FOR REPAIR INSTRUCTIONS ONLY.

Parts listing is for reference only. All parts listed for the ERD06 are limited to stock on hand. Contact Tolomatic regarding availability.