

QTI, CSTM, BELT DRV, SNGL ACTUATOR

Models: 00040001

EXPLODED VIEW - 00040001

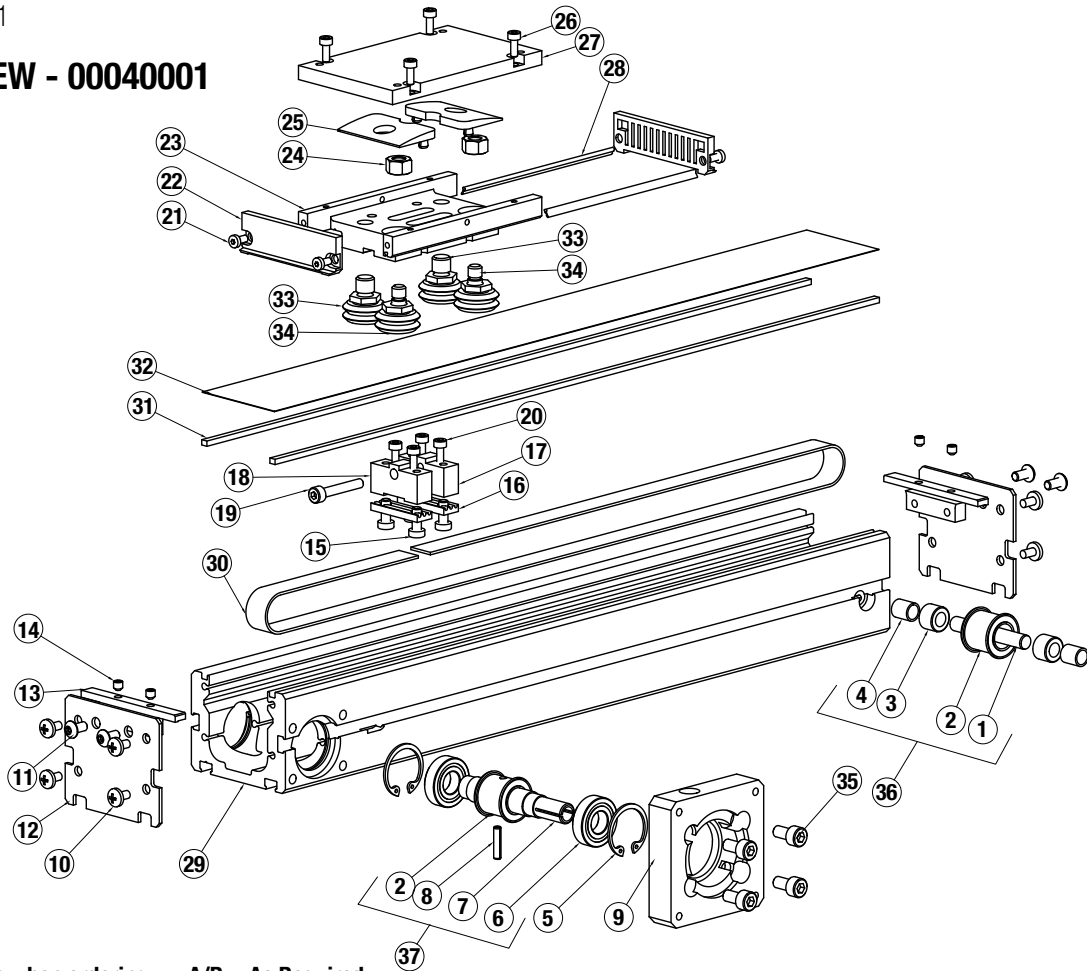

*Specify stroke length when ordering A/R = As Required
 **Specify Right Hand Drive or Left Hand Drive when ordering

ITEM	PART NO or Config. Code	DESCRIPTION	QTY.
1	0004-1013	Dowel Pin	1
2	3417-1421	Pulley	2
3	1080-1010	Roller Bearing	2
4	0004-1021	Spacer	2
5	3410-1207	Retaining Ring	2
6	0004-1004	Bearing	2
7**	0004-1014	Drive Shaft	1
8	2750-1127	Roll Pin	1
9**	0004-1024	Adapter Plate	1
10	0601-1625	Self Tapping Screw	8
11	0510-1370	Button Head Cap Screw	4
12	0004-1016	Cover Plate	2
13	0004-1007	Band Clamp	2
14	2132-1084	Set Screw	4
15	8125-1070	Low Head Cap Screw	4
16	0004-1008	Belt Clamp Bottom	2
17	0004-1009	Belt Clamp Top, Threaded	1
18	0004-1010	Belt Clamp Top	1
19	0601-1674	Socket Head Cap Screw	1

ITEM	PART NO or Config. Code	DESCRIPTION	QTY.
20	0604-2088	Socket Head Cap Screw	4
21	8116-1076	Low Head Cap Screw	4
22	0004-1015	End Cap	2
23	0004-1011	Carrier	1
24	3410-3045	Nut	2
25	3415-1047	Upper Band Ramp	2
26	2212-1090	Socket Head Cap Screw	4
27	0004-1012	Carrier Top	1
28	0004-1020	Wiper	2
29*	0004-1017	Tube	1
30*	0004-1005	Belt	1
31*	0004-1003	Magnet Strip	2
32*	0004-1006	Dust Band	1
33	0004-1022	Concentric Roller	2
34	0004-1023	Eccentric Roller	2
35	0603-1016	Socket Head Cap Screw	4
36		Idle Pulley Assembly	1
37		Drive Pulley Assembly	1

GENERAL ACTUATOR DISASSEMBLY

1. Move the Carrier (23) so it is about 3" from the drive end of the actuator and remove the Adapter Plate (9). Remove the two End Caps (22) and the Top Carrier (27). Loosen the two Set Screws (14) on each end of the actuator then remove the two Cover Plates (12) and the Dust Band (32).
2. On the Carrier (23), remove the two Upper Band Ramps (25) and the four SHCS (20) securing the Top Belt Clamps (17, 18). Once the Carrier (23) is free from Belt Clamps (17, 18) slide the Carrier (23) off the actuator.
3. From the drive end, remove Socket Head Cap Screws (20) from Top Belt Clamps (17, 18). Remove the Bottom Belt Clamps (16) from each Top Belt Clamp (17, 18) by removing the Low Head Cap Screw (15). Remove Belt (30) and all Belt Clamps (16, 17, 18) from the actuator.
4. Remove the Retaining Rings (5) from each side of the Tube (29). Remove the Drive Pulley Assembly (37).

NOTE: The bearings are slip fit into the Tube (29) and are bonded in the bore with Loctite 641. It may be necessary to press the bearing out of the Tube (29).

5. The Idle Pulley Assembly (36) is pressed into the Tube (29) opposite the side with the counter bore. The counter bore side is slip fit. Measure and record the depth of the Idle Pulley Assembly (36) in the Tube (29). With the counter bore side down, press out the Idle Pulley Assembly (36). As the shaft of the Idle Pulley Assembly (36) exits the Tube (29), capture the two Spacers (4) and the Pulley (2).
6. **Carrier Disassembly:** Remove the two Wipers (28) from Carrier (23). Remove the Concentric Rollers (33) and the Eccentric Rollers (34) with Nut (24).

NOTE: Do not remove the Rollers (33, 34) unless they need to be replaced. If the Eccentric Rollers (34) are loosened the Carrier (23) will no longer fit properly into the Tube (29) without adjustment.

GENERAL ACTUATOR ASSEMBLY

1. Place Belt (30) flat on bottom surface of Tube (29) and install the Top Belt Clamp (18) with Bottom Belt Clamp (16) and Low Head Cap Screw (15) onto the end of Belt (30) to be located on the drive end of the actuator. Install the Top Belt Clamp (17) with Bottom Belt Clamp (16) and Low Head Cap Screw (15) onto other end of the Belt (30).

NOTE: Fit the teeth of the Belt (30) with the teeth in the Bottom Belt Clamps (16). Top Belt Clamp (18) has a through hole and Top Belt Clamp (17) has a threaded hole.

2. Install one Retaining Ring (5) into the bore in the drive end of the Tube (29). Apply a thin layer of Loctite 641 onto the outside diameter of both bearings of the Drive Pulley Assembly (37) and both bores in the drive end of the Tube (29). Install the Drive Pulley Assembly (37) into the bores in the Tube (29). **NOTE THAT ORIENTATION OF THE DRIVE SHAFT IS DETERMINED BY THIS ASSEMBLY STEP.** Install the remaining Retaining Ring (5) into the Tube (29).
3. Start the shaft of the Idle Pulley Assembly (36) through the counter bored hole in the Tube (29). While sliding the shaft across the Tube (29) to the other hole, insert a Spacer (4) then the Pulley (2) then the other Spacer (4) onto the shaft. Apply a thin layer of Loctite 641 into the hole in the Tube (29). Press the shaft into hole to the depth earlier recorded.
4. Wrap Belt (30) around Drive (7) and Idle Pulley (1) assemblies and use Socket Head Cap Screws (20) to secure Top Belt Clamps (17, 18). Tighten Socket Head Cap Screw (19) to achieve the proper tension in the Belt (30).
5. If the Carrier (23) needs to be adjusted to the Tube (29), make sure the Concentric Rollers (33) are tightened onto the Carrier (23). Adjust each Eccentric Roller (34) individually. The Eccentric Roller (34) has a cam to allow for adjustment. Install the Eccentric Roller (34) by securing it to the Carrier (23) with Nut (24). Adjust the Eccentric Roller (34) until the Carrier (23) can go into the Tube (29) without kicking sideways when entering the Tube (29). Rotate Carrier (23) 180° and adjust the other Eccentric Roller (34). Install Carrier (23) into Tube (29) and secure the Carrier (23) to both Top Belt Clamps (17, 18) using Socket Head Cap Screws (20). Adjust belt tension if needed by tightening or loosening Socket Head Cap Screw (19).
6. Install a Cover Plate (12) onto each end of the Tube (29) using Button Head Cap Screw (10).

NOTE: Band Clamp (13) and Set Screws (14) are already attached to Cover Plate (12) with Button Head Cap Screw (11).

7. Install Upper Band Ramps (25) and Wipers (28) into Carrier (23).
8. Place Dust Band (32) on top of Carrier (23) and along entire length of the Tube (29). The Dust Band (32) is held down with Magnet Strips (31). Install End Cap (22) to each end of the Carrier (23) using Low Head Cap Screws (21). Install Top Carrier (27) to Carrier (23) using Socket Head Cap Screws (26).
9. Insert end of Dust Band (32) under Band Clamp (13) and secure Dust Band (32) by tightening Set Screws (14). Repeat on other side of Tube (29).
10. Install Adapter Plate (9) to Tube (29) using Socket Head Caps Screws (35).



3800 County Road 116, Hamel, MN 55340
<http://www.Tolomatic.com> • Email: Help@Tolomatic.com
 Phone: (763) 478-8000 • Fax: (763) 478-8080 • Toll Free: 1-800-328-2174



Information furnished is believed to be accurate and reliable. However, Tolomatic assumes no responsibility for its use or for any errors that may appear in this document. Tolomatic reserves the right to change the design or operation of the equipment described herein and any associated motion products without notice. Information in this document is subject to change without notice.