

CONTROLLERS, DRIVES, MOTORS, INTERFACES
RODLESS ACTUATORS, ROD SCREW ACTUATORS,
GUIDED SCREW ACTUATORS

Visit
www.tolomatic.com to get
the most up-to-date technical
information.

ALL CATALOG PRODUCTS ARE
MANUFACTURED TO FIT YOUR
APPLICATION REQUIREMENTS AND ARE
SHIPPED IN 5 DAYS OR LESS FROM OUR
IN-HOUSE MANUFACTURING FACILITY

TOL-O-MATIC HAS THE RESOURCES TO HELP YOU GET WHAT YOU NEED.

PRODUCTS AND PEOPLE YOU NEED TO GET THE JOB DONE RIGHT.

At Tol-O-Matic we have the resources and the experience to give you what you need when you need it. Working together we can find solutions whether it is a new feature, better performance or a whole new product line. Our sales department will make sure all your questions are answered. Our engineers will assist you with your application design. Our model shop will make all the tooling and specials you need for a new product —not in 6 months or a year—but when you need them.

QUALITY PRODUCTS, COMPETITIVELY PRICED WHEN YOU WANT THEM.

Our engineering laboratory pushes our products to the breaking point running them 24 hours a day, 7 days a week for millions of cycles looking for ways to improve them. They work with R&D to develop new manufacturing techniques and to perfect new products. For each new product, detailed engineered drawings are converted into hand-crafted sample products for testing, then precision tooling is built on site by Tol-O-Matic's own skilled craftsmen with the highest standards of quality, care and dedication to details. The products are tested again by engineering and by selected field representatives. Tol-O-Matic has heavily invested in research to guarantee you delivery of the highest quality products not in months or weeks, but within days of your order, and with a warranty rate less than 1/2 of 1%.

UNCONDITIONAL 100% SATISFACTION GUARANTEE.

Tol-O-Matic has built its reputation on customer satisfaction. For almost 50 years it has been our policy that, if for any reason you have a problem with any Tol-O-Matic product ordered, we will do whatever it takes to make sure you are 100% satisfied. Working together we will arrive at a solution that works best for you.

TOL-O-MATIC TRAINING CENTER

There is a Tol-O-Matic product for just about every application that may come your way and it is our goal to remove every obstacle, give you every tool, device and piece of knowledge necessary to learn how to size and apply Tol-O-Matic products. That is why we supply the most advanced in-depth training in the industry— free of charge to all our distributors and their customers.



Located in west suburban Minneapolis, Minnesota, Tol-O-Matic headquarters (a 100,000 sq. ft. state-of-the-art facility) is designed for improved communication and manufacturing techniques to meet customer needs today and well into the future.

© Copyright 2003, Tol-O-Matic, Inc. All rights reserved. No part of this publication may be reproduced, transmitted, transcribed, stored in a retrieval system, or translated into any language in any form by any means without the written permission of Tol-O-Matic, Inc.

Tol-O-Matic, Axidyne, and Excellence in Motion are registered trademarks, Tol-O-Matic, Inc. Other product and corporate names may be trademarks of other companies, and are used only for explanation and to the owner's benefit, without intent to infringe.

Information furnished in this catalog is believed to be accurate and reliable. However, Tol-O-Matic assumes no responsibility for its use or for any errors that may appear in this document. Tol-O-Matic reserves the right to change the design or operation of the equipment described herein and any associated motion products without notice. Information in this document is subject to change without notice.

09/2003 • 15M • CG

CONTENTS

ABOUT TOL-O-MATIC

DEDICATED TO YOUR SATISFACTIONA-2 WORLD CLASS MOTION PRODUCTSA-3 APPLICATION EXAMPLESA-4

PRODUCT OVERVIEW

AXIDYNE SYSTEM COMPONENTSB-2 MOTOR COMPARISONB-10 RSA/RSM SERIESB-15
 SYSTEM SELECTION ADVICEB-3 TK SERIESB-12 GSA/GSM SERIESB-16
 SIZING & SELECTION SOFTWAREB-4 B3/M3 SERIESB-13 MOTORS/CONTROLS/DRIVESB-17
 ACTUATOR COMPARISONB-8 SLS/MLS SERIES, BCS SERIESB-14

RODLESS ACTUATORS

B3S/M3S SERIES SCREW DRIVES	TKS TRUTRACK SERIES SCREW DRIVES	TKB75C-101
OVERVIEW AND OPTIONSC-2	OVERVIEW AND OPTIONSC-51	ORDERINGC-104
OVERALL SERIES SPECIFICATIONSC-3	OVERALL SERIES SPECIFICATIONSC-52	BCS/MCS SERIES SCREW DRIVES
B3S/M3S10C-11	TKS10C-59	OVERVIEW AND OPTIONSC-105
B3S/M3S15C-17	TKS25C-64	OVERALL SERIES SPECIFICATIONSC-106
B3S/M3S20C-24	TKS50C-70	B3S/MCS10C-112
ORDERINGC-30	TKS75C-76	B3S/MCS15C-117
B3B/M3B SERIES BELT DRIVES	ORDERINGC-81	B3S/MCS20C-123
OVERVIEW AND OPTIONSC-31	TKB TRUTRACK SERIES BELT DRIVES	ORDERINGC-128
OVERALL SERIES SPECIFICATIONSC-32	OVERVIEW AND OPTIONSC-83	SLS/MLS SERIES SCREW DRIVES
B3B/M3B10C-38	OVERALL SERIES SPECIFICATIONSC-84	OVERVIEW AND OPTIONSC-129
B3B/M3B15C-42	TKB10C-90	SLS10C-130
B3B/M3B20C-46	TKB25C-93	ORDERINGC-138
ORDERINGC-50	TKB50C-97	

ROD SCREW ACTUATORS

OVERVIEW AND OPTIONSD-2	RSA/RSM16D-18	RSA/RSM50D-39
OVERALL SPECIFICATIONSD-4	RSA/RSM24D-25	RSA/RSM64D-46
RSA/RSM12D-10	RSA/RSM32D-32	ORDERINGD-53

GUIDED SCREW ACTUATORS

OVERVIEW AND OPTIONSE-2	GSA/GSM16E-18	ORDERINGE-36
OVERALL SPECIFICATIONSE-4	GSA/GSM24E-24	
GSA/GSM12E-11	GSA/GSM32E-30	

BRUSHLESS SERVO MOTORS/CONTROLS/INTERFACES

MRV MOTORSF-3	AXIOM PV DRIVE/CONTROLLERF-18	CABLESF-32
GEARHEAD REDUCTIONF-10	SSC CONTROLLERF-25	ORDERINGF-33
AXIOM DV DRIVEF-11	USER INTERFACESF-30	

MICROSTEPPING MOTORS/CONTROLS/INTERFACES

MRS MOTORSG-3	MSS DRIVE/CONTROLLERG-10	CABLESG-22
GEARHEAD REDUCTIONG-6	SSC CONTROLLERG-13	ORDERINGG-23
MSD DRIVEG-7	USER INTERFACESG-19	

BRUSHED DC MOTORS/CONTROLS/INTERFACES

MRB MOTORSH-3	MSC CONTROLLERH-13	CABLESH-25
GEARHEAD REDUCTIONH-6	SSC CONTROLLERH-16	ORDERINGH-26
AXIOM DB DRIVEH-7	USER INTERFACESH-22	

SWITCHES

SPECIFICATIONSI-3 COUPLERS AND KITSI-4 MOUNTING DIMENSIONSI-6

ENGINEERING RESOURCES

GLOSSARYJ-2	RODLESS SELECTION FACTORSJ-10	ROTARY MOTOR SELECTIONJ-19
CONVERSION TABLESJ-5	ROD SCREW SELECTION FACTORSJ-13	
MOTION PROFILESJ-6	GUIDED SCREW SELECTION FACTORSJ-16	

ABOUT TOL-O-MATIC

A



PRODUCT OVERVIEW

B



RODLESS

C



ROD SCREW

D



GUIDED SCREW

E



BRUSHLESS

F



MICROSTEPPING

G



BRUSHED DC

H



SWITCHES

I



RESOURCES

J



About Tol-O-Matic

ABOUT TOL-O-MATIC

Dedicated to your satisfaction

- Proven products
- Fastest delivery
- High quality
- Applied knowledge
- Multiple technologies
- Flexibility
- Satisfaction guaranteed

WE ARE DEDICATED TO YOUR SATISFACTION

Tol-O-Matic employees are proud of the quality, performance and reliability of the products we make. We are committed to give you the best speed, price, service, and delivery possible.

We Build Proven Products

- 50 years of building motion products.



Choose from Multiple Technologies

- Use fluid power systems, Axidyne electric systems and power transmission technology for the accurate motion that meets your price needs.



Our Delivery is the Industry's Fastest

- Actuators built your way in just 5 days.



We offer Flexibility

- We frequently modify standard catalog products and create totally unique designs to meet special motion, space, load and accuracy requirements.



Our High Quality Commitment

- ISO 9001:2000 certified quality system provides assurance that our products are built to specific quality guidelines.



Your Satisfaction is Guaranteed

- At Tol-O-Matic we will do whatever it takes to make sure you are 100% satisfied.



Apply Our Knowledge

- Everyone at Tol-O-Matic thinks of themselves as part of the sales staff. Call us for answers 1-800-378-2174.



CALL US TODAY, WE WILL DELIVER OUR BEST.

About Tol-O-Matic

ABOUT TOL-O-MATIC

World class motion products

- Standard catalog products
- Modified standard products
- Custom products

WORLD CLASS MOTION CONTROL PRODUCTS

STANDARD CATALOG PRODUCTS



High accuracy motion systems complete with motors, drives, controllers and software.

Our standard catalog product line contains over 1,450 choices and more than 1/3 of these are built to your specified stroke length. We make it easy for you to select any of our motion control products:

- Use our Tol-O-Motion™ sizing and selection software
- Call our network of distributors and representatives
- Call our customer service representatives and technical sales coordinators at the factory.

Standard catalog products are just a portion of what Tol-O-Matic has to offer.

MODIFIED STANDARD PRODUCTS



This standard B3S has a nickel plated extrusion, other parts are made of stainless-steel. A special mounting bracket supports a nonstandard motor

Modified standard products are catalog products modified to your unique needs. Different tapped holes, material, coatings, and mounting brackets are commonly requested. Modifications can accommodate anything from harsh operating environments, unusual mounting needs to the use of nonstandard motors. Call Tol-O-Matic for price and delivery time required.

CUSTOM PRODUCTS

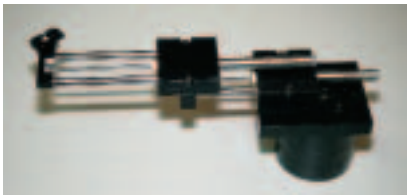

This multi-axis actuator doesn't resemble any of our standard catalog products. It was built to fit a manufacturer's motion space load and accuracy requirements.

Custom products are a blank page. They can be revisions of existing products or completely new actuators. Our engineering team enjoys the challenge of creating unique products that will meet your design constraints.

Axidyne Application Solutions

ABOUT TOL-O-MATIC

Axidyne Application Solutions

- Surgical tubing winder
- Positioning tables

SURGICAL TUBING WINDER

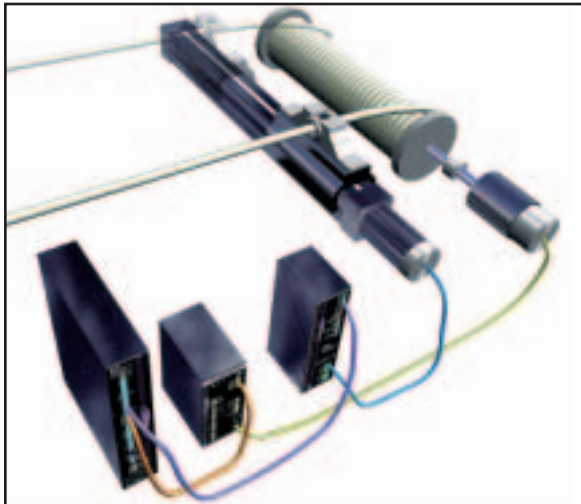

Application description:

A manufacturer of surgical tubing winds the tubing on a spool with a constant tension, which is critical so as not to deform the tubing shape or size.

Application requirements:

- Constant tension provided by winding spool
- Reciprocating tube position guide
- Tube guide and tensioning must compensate for process speed variations

Tol-O-Matic solution:

For precise tension control, the AXIOM DV10 drive operates in torque mode, with a MRV brushless servo motor and provides an optimal solution. The controller must be able to provide torque adjustment that is inversely proportional to the spool diameter. This adjustment will be made each time the tube position guide changes direction. The controller must also be able to provide linear interpolation between the spool motor position and the reciprocating tube guide position. A low-cost solution for the reciprocating guide is a BCS Series screw-drive actuator driven by the MSD microstepping drive and an MRS series stepper motor. Therefore, the controller must be able to provide an analog torque signal for the servo drive as well as a step-and-direction signal for the microstepping drive. Also, the controller must be able to supply a correction algorithm for tension control with linear interpolation between the two axes. The controller for this application is the SSC2 two axis/multi-function controller.

Tol-O-Matic System Components:

- SSC2 two axis controller
- AXIOM® DV10 digital brushless servo drive/MRV brushless servo motor
- MSD microstepping drive/MRS stepper motor
- BCS screw drive rod bearing actuator
- Motor couplings, motor adapters and cabling automatically selected using the Tol-O-Motion™ sizing software configuration generator

POSITIONING TABLES

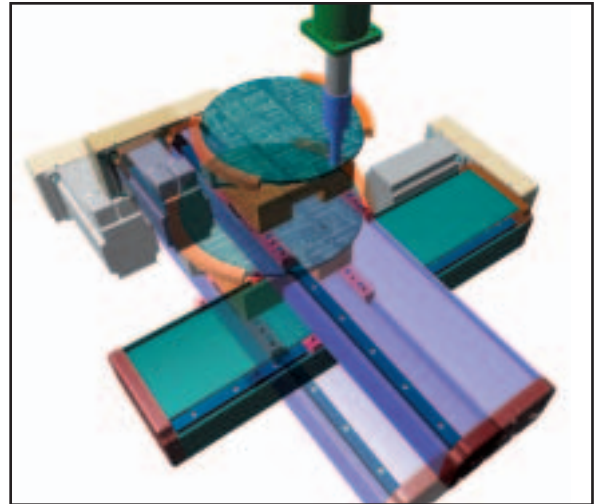

Application description:

A manufacturer is making positioning tables which move under a sensor used to measure the solder levels on a printed circuit board. A two-axis motion controller with a PLC is part of their existing set-up.

Application requirements:

- Two actuators mounted carrier-to-base
- Minimized vibration
- Attractive Package
- Motor and Drive for each axis
- Speed requirement of 4 inches per second for each axis
- Space is limited
- Cost-effective drive/motor/actuator package
- Maximum load deflection: .0001"

Tol-O-Matic solution:

Space is a concern in this application, so the TKS10 screw-drive actuator with a reverse parallel option was selected to reduce length. Two 23-frame stepper motors were selected for the most cost-effective solution since high speeds and torque were not required. An MSD micro-stepping drive was chosen to accept standard step-and-direction signals.

Tol-O-Matic System Components:

- Two TruTrack TKS10 screw-drive actuators with reverse parallel mounting configuration
- Two MSD microstepping drives
- Two MRS231 stepper motors
- All motor couplings, motor adapters and cabling automatically selected using the Tol-O-Motion™ sizing software configuration generator

Axidyne Application Solutions

ABOUT TOL-O-MATIC

SCANNING DEVICE

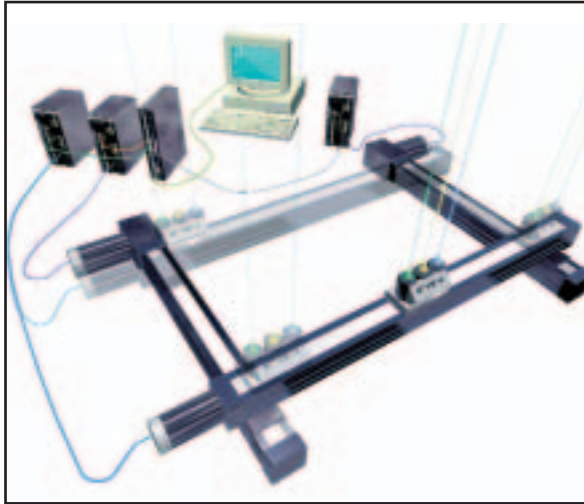

Application description:

The developer of a new scanning device requires a method of traversing 48 inches on the X-axis in less than 1 second and then indexing along the Y-axis over a distance of 72 inches following each X-axis scan.

Application requirements:

- X-Y positioning of a 50 lb. scanning head
- 48-inch X-axis move in less than 1 second
- 72-inch Y-axis travel distance
- Better than 0.010-inch repeatability

Tol-O-Matic solution:

Speed and stroke requirements in the X-axis do not allow the use of a screw actuator. The moment load generated by the scanning head and 72-inch Y-axis does not allow a single actuator to be used for the X-axis. Therefore, two B3B15 belt-drive actuators were used in the gantry configuration shown. The speed requirements also do not allow the use of stepper or brushed dc systems. MRV brushless servo motors, driven by the AXIOM DV drives were used in this system and controlled by a three-axis SSC3 controller. The two X-axis motors/drives were electronically geared together while operating the third axis independently. Programming was done over RS232 from a PC using the user friendly Tol-O-Motion™ SSC programming software.

Tol-O-Matic system components:

- SSC3 three-axis multifunction controller
- Two AXIOM® DV20 digital servo drives
- Two MRV31 brushless servo motors
- AXIOM® DV10 digital servo drive
- Two B3B15 belt-drive actuators
- B3S10 screw-drive actuator
- Motor couplings, motor adapters and cabling automatically selected using the Tol-O-Motion™ sizing and selection software configuration generator

PARTS GRINDER

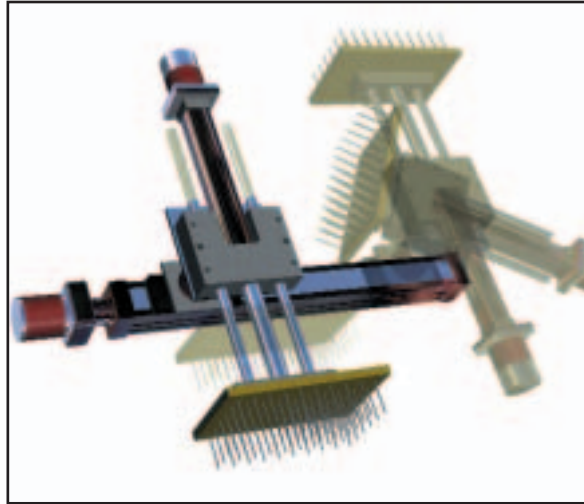

Application description:

A manufacturer wants to design a machine that will grind 500 small parts at a time to the the same length within 0.0005" repeatability.

Application requirements:

- Three axes: Main axis to move the parts back and forth, rotating axis to rotate the parts 180° before grinding, and a screw actuator with guidance to compensate for wear on the grinder.
- User interface to allow operator to select part numbers, batch sizes and move distances for grinding compensation.
- 18" stroke on main actuator, and 4" stroke on the grinder indexer.

Tol-O-Matic solution:

Selected for the main axis is a B3S15 with 2TPI low backlash ball nut, driven by a MRS233 stepper motor. Rotation is supplied by a 23-frame stepper motor and gearhead reduction. A GSA24 guided screw actuator indexes the parts to the grinder forward and backward. The operator can input a "Delta" value based on periodic quality checks during the process.

Tol-O-Matic System Components:

- SSC3 multi-axis controller
- Three MSD microstepping drives
- Three MRS stepper motors
- B3S15 screw-drive actuator
- GSA24 guided screw actuator
- Motor couplings, motor adapters and cabling automatically selected using the Tol-O-Motion™ sizing and selection software configuration generator

Axidyne Application Solutions

- Scanning device
- Parts grinder

Axidyne Application Solutions

ABOUT TOL-O-MATIC

Axidyne Application Solutions

- Volumetric Filling
- Lens Gluer

VOLUMETRIC FILLING

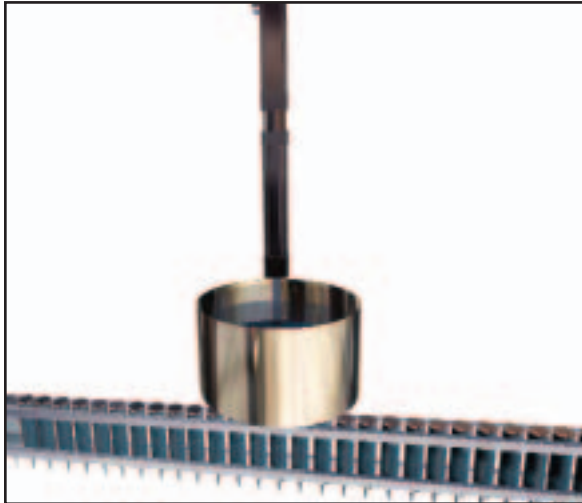

Application description:

A volumetric filler machine currently uses a pneumatic cylinder to operate a piston pump. Product is being wasted as a result, due to lack of precision.

Application requirements:

- Precise volume control, accurate fill rate
- Quick change between products
- Stroke: 8 inches
- Force: approximately 200 lbs.
- Easy to set up and program

Tol-O-Matic solution:

Due to the torque demand of this application, a brushless servo system was the best choice. For this basic single-axis application, the Axiom®Plus PV10 controller/drive was selected along with an MRV23 servo motor. The RSA50 actuator with the 1" diameter acme screw, was the best selection for the given thrust requirement.

Tol-O-Matic System Components:

- Axiom®Plus PV10 controller/drive
- MRV23 brushless servo motor
- RSA50 rod screw actuator
- Motor couplings, motor adapters and cabling automatically selected using the Tol-O-Motion™ sizing and selection configuration generator.

LENS GLUER

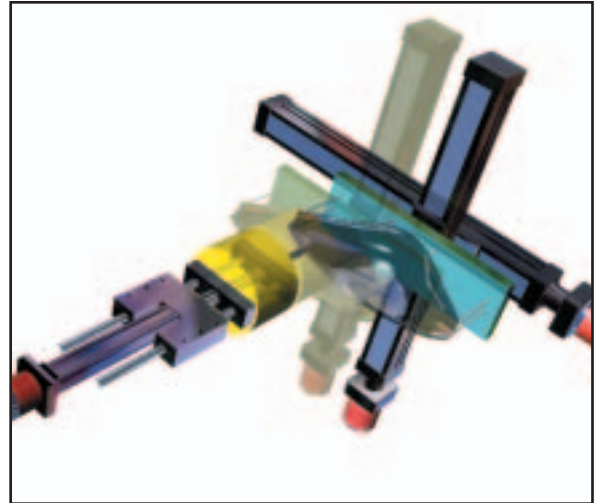

Application description:

A snowmobile lens manufacturer wants to put a bead of adhesive in the groove on the edge of a lens. Cycle time per lens is 20 seconds. The weight of the lens and nest is no more than 10 pounds. The weight of the glue gun is 4 pounds maximum.

Application requirements:

- Velocity control
- Interface to joystick
- Stroke requirements: x axis- 12", Y-axis-24", Z-axis-40"
- Less than 10 pound load for lens and nest
- Less than 4 pound load for glue gun
- 3" per second maximum speed for movement of lens and nest (B3S axes). Glue gun (GSA axis) to follow the curvature of the lens

Tol-O-Matic solution:

Two B3S15s are used to supply motion to the lens and nest. A B3S15 with 40" stroke and a 2TPI ball screw is selected for the Z-axis. The Y-axis uses a B3S15 with 24" stroke and a 5TPI ball screw. A GSA16 with a stroke of 12" moves the glue gun on the X-axis. It uses a 1TPI acme screw. All three actuators use a MRB21 brush motor. The SSC31 controller completes the system, along with a joystick utilizing teach mode to make the required moves.

Tol-O-Matic System Components:

- SSC3 three-axis servo controller
- MRB21 brush motors
- GSA16 guided screw actuator
- 2-B3S15 screw-drive actuators
- Motor couplings, motor adapters and cabling automatically selected using the Tol-O-Motion™ sizing and selection software configuration generator



SYSTEM COMPONENTS AND SELECTION

- Axidyne motion system components
- System selection
- Using the Tol-O-Motion sizing software
- Actuator basics
- Motor system basics



ACTUATOR SERIES AND FEATURES

- Rodless actuator families and features
- Rod style actuator features
- Guided rod screw actuator features



DRIVE SYSTEMS

- Brushless servo system basic components and features
- Microstepping system basic components and features
- Brushed dc servo system basic components and features

Axidyne® System Components and Selection

AXIDYNE ELECTRIC LINEAR MOTION SYSTEM COMPONENTS

PRODUCT OVERVIEW

Axidyne System Components

- Axidyne Electric Linear Motion Systems

- A mechanical actuator to convert motor rotary motion to linear motion.
- A motor to convert electrical energy to mechanical energy in the form of rotary motion.
- A drive to interpret the incoming command and motor position signal, and provide a corresponding conversion of line voltage to appropriately phased voltage for the motor.
- A controller to store and/or interpret high level commands received from a computer or operator interface, and to generate the necessary signals to control motor velocity, acceleration, position, and direction based on program and discrete inputs.
- An operator interface to allow system operators to program or signal the controller remotely.

This modular approach provides flexibility in control system design and helps provide the most cost-effective solution to a range of linear motion control requirements.

MOTOR: MRV - BRUSHLESS SERVO (SHOWN)
MRS - MICROSTEPPING
MRB - BRUSHED DC

ACTUATOR: B3S/M3S - B3 SCREW-DRIVE ACTUATOR
B3B/M3B - B3 BELT-DRIVE ACTUATOR
TKS - TRU-TRACK SCREW-DRIVE ACTUATOR
TKB - TRU-TRACK BELT-DRIVE ACTUATOR (SHOWN)

BCS - BC SCREW-DRIVE ACTUATOR
SLS/MLS - LS SCREW-DRIVE ACTUATOR
RSA/RSM - ROD SCREW ACTUATOR
GSA/GSM - GUIDED SCREW ACTUATOR (SHOWN)

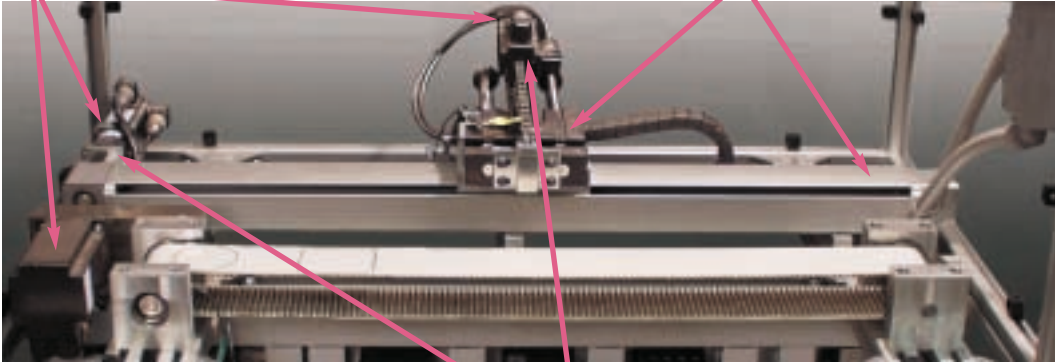

CONTROLLER:
SSC - MULTI-AXIS/MULTI-FUNCTION SERVO/STEPPER CONTROLLER (SHOWN)
MSC - SINGLE-AXIS SERVO/STEPPER CONTROLLER

MOTOR MOUNT, SCREW-DRIVE:
RP - REVERSE PARALLEL
LMI - INLINE (SHOWN)

MOTOR MOUNT, BELT-DRIVE:
DIRECT DRIVE (SHOWN)
REDUCTION DRIVE



CONTROLLER/DRIVE COMBINATIONS:
AXIOM® PV - BRUSHLESS CONTROLLER/DRIVE
MSS - MICROSTEPPING CONTROLLER/DRIVE

DRIVE: AXIOM® DV - BRUSHLESS DRIVE (SHOWN)
AXIOM® DB - BRUSHED DC DRIVE
MSD - MICROSTEPPING DRIVE

OPERATOR INTERFACES:
JS - JOYSTICK
SIT - HAND-HELD
PIT - PANEL MOUNT
HOST COMPATIBLE PC

Axi-dyne® System Components and Selection

A SIMPLE 2-STEP PROCESS

1) DETERMINE THE REQUIREMENTS OF YOUR APPLICATION:

Be sure to include:

_____ Stroke Length	_____ Load Weight	_____ Thrust Force
_____ Moment Loads	_____ Resolution/Repeatability	_____ Actuator Orientation
_____ Duty Cycle	_____ Motion Profile	

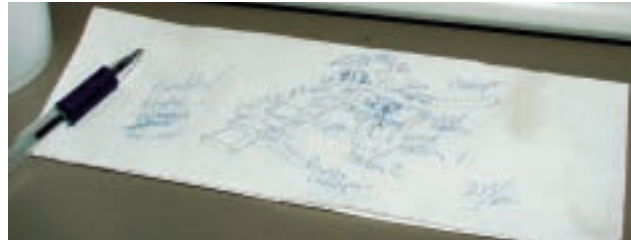

PRODUCT OVERVIEW

Axidyne System Selection

- 2-step selection

2) USE TOL-O-MOTION™ SIZING & SELECTION SOFTWARE.

Our easy to use software leads you through the selection process step-by-step, making it easy to choose the right combination of products in a user-friendly Windows® format. The next few pages give you an overview of the software. You can be sure that the components selected are 100% compatible and backed by Tol-O-Matic's satisfaction guarantee. The software is available free on CD or on our web site: www.tolomatic.com

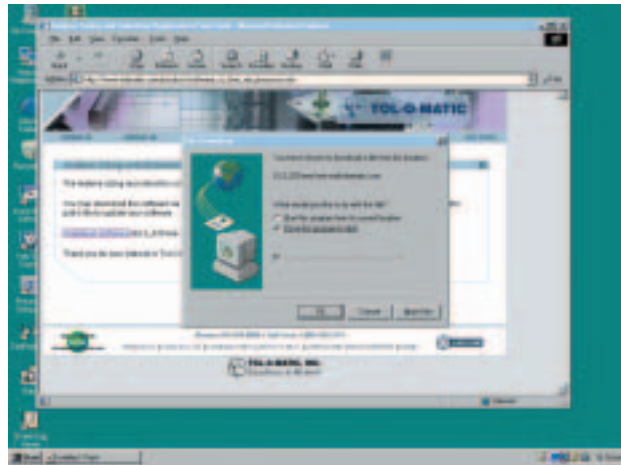

OR

2) CALL TOL-O-MATIC 1-800-328-2174

Tol-O-Matic, your local distributor or representative can take your information and determine the most cost-effective Axidyne system for your application. (Find your local distributor at www.tolomatic.com)



Axi-dyne® System Components and Selection

USING THE SIZING & SELECTION SOFTWARE

TOL-O-MOTION SIZING & SELECTION SOFTWARE

PRODUCT OVERVIEW

Using Tol-O-Motion Sizing & Selection Software

- Menu bar
- Actuator choice
- Stroke length and orientation
- Motion profile

This easy, step-by-step process for selecting your electric motion system, eliminates the time and hassle of mixing, matching and integrating components.

Once all required application parameters are entered, the software will calculate performance required and display a list of compatible systems. By default the list is sorted by price but it can also be sorted by motor performance.

PRESSING THE F1 (HELP) BUTTON, AT ANY TIME, DISPLAYS SOFTWARE HELP AS WELL AS AN EXTENSIVE INDEX OF TOL-O-MATIC PRODUCT INFORMATION

Menu Bar



THE SOFTWARE WILL DIRECT YOU STEP-BY-STEP THROUGH THE INFORMATION NEEDED TO SELECT THE CORRECT AXIDYNE SYSTEM. USE THE GRAPHICAL USER INTERFACE TO POINT-AND-CLICK AND FILL IN THE BLANKS. AT ANY TIME YOU MAY JUMP BETWEEN WINDOWS TO MODIFY THE SYSTEM PARAMETERS AND/OR COMPONENTS.

1. Select actuator style

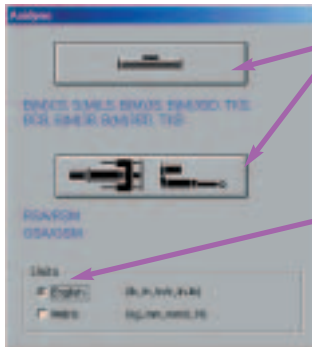

CHOOSE EITHER A ROD OR RODLESS STYLE ACTUATOR

SELECT EITHER ENGLISH OR METRIC MEASUREMENT DISPLAY

2. Select stroke length and orientation

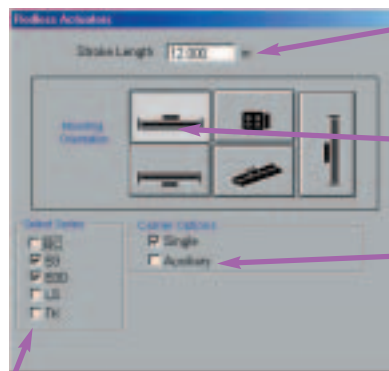

ENTER THE DESIRED ACTUATOR STROKE LENGTH

CHOOSE THE MOUNTING ORIENTATION OF THE ACTUATOR

SELECT EITHER THE STANDARD SINGLE CARRIER OR THE AUXILIARY (2ND CARRIER) OPTION

SELECT THE ACTUATOR SERIES FOR THE SOFTWARE TO EXAMINE (MORE THAN ONE MAY BE SELECTED)

3. Create a motion profile

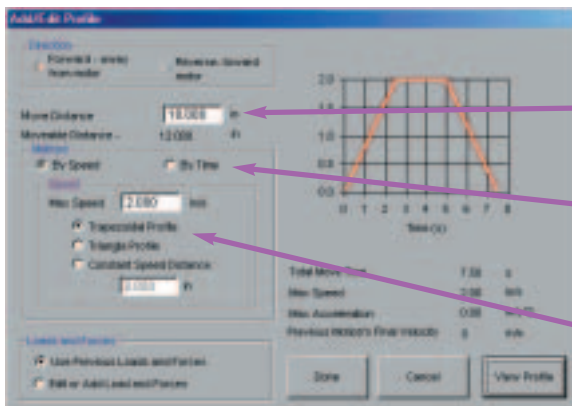

ENTER THE DESIRED MOVE DISTANCE

SELECT THE MOTION METHOD
• BY TIME, OR
• BY SPEED

MOTION PROFILE CAN BE SELECTED AS TRAPEZOIDAL OR TRIANGULAR

ACCELERATION AND DECELERATION RATES ARE ADJUSTABLE.

Axi-dyne® System Components and Selection

USING THE SIZING & SELECTION SOFTWARE

4. Define load weights and moments

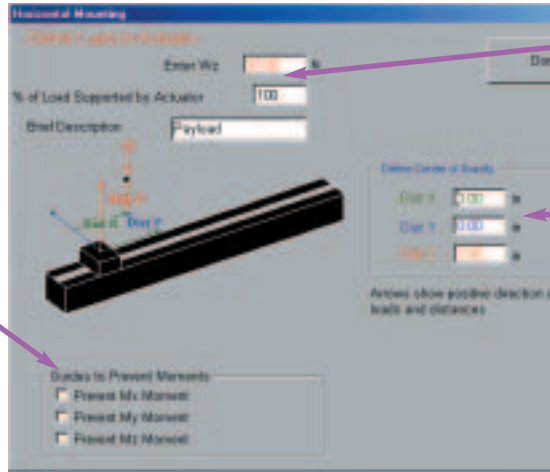

ENTER THE LOAD AND MOMENT FOR YOUR APPLICATION

DEFINE THE CENTER OF GRAVITY

CHECK THE APPROPRIATE BOXES IF YOUR APPLICATION IS EXTERNALLY GUIDED AND SUPPORTED

PRODUCT OVERVIEW

Using Tol-O-Motion Sizing & Selection Software

- Load weights and moments
- Thrust force
- Motor system

5. Define the thrust force

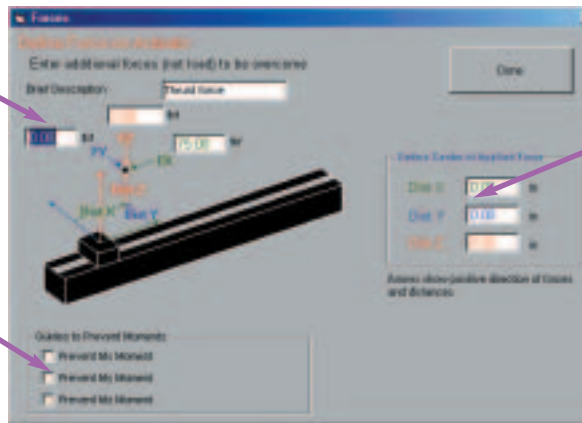

ENTER THE THRUST FORCE REQUIRED FOR YOUR APPLICATION

DEFINE THE CENTER OF APPLIED FORCE REQUIRED FOR YOUR APPLICATION

CHECK THE APPROPRIATE BOXES IF YOUR APPLICATION IS EXTERNALLY GUIDED AND SUPPORTED

6. Select a motor system

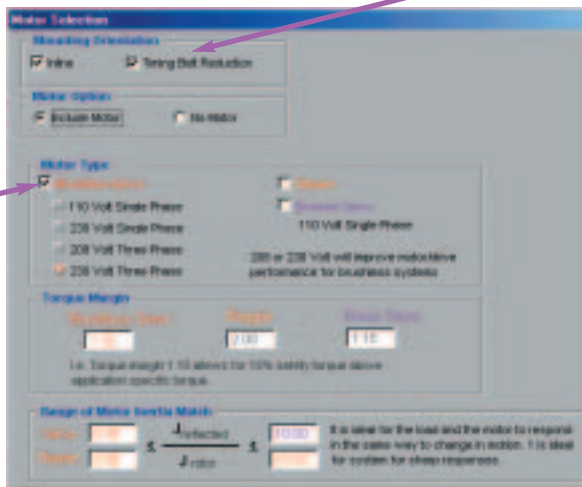

CHOOSE THE MOTOR ORIENTATION:

- IN-LINE
- REVERSE PARALLEL

CHOOSE THE MOTOR TYPE:

- BRUSHLESS SERVO
- BRUSHED DC
- MICROSTEPPING (MULTIPLE MOTOR CHOICES MAY BE SELECTED FOR LATER COMPARISON)

Axi-dyne® System Components and Selection

USING THE SIZING & SELECTION SOFTWARE

PRODUCT OVERVIEW

Using Tol-O-Motion Sizing & Selection Software

- Controller and options
- Combination selection

SELECT THE APPROPRIATE CONTROLLER DEPENDING UPON YOUR MOTOR SYSTEM

7. Select controller and options

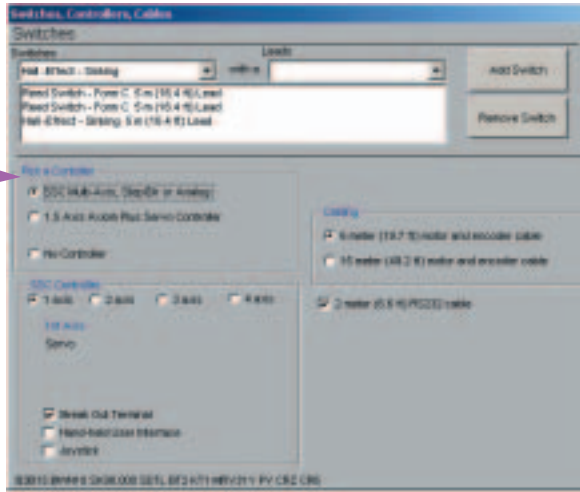

8. Review the possible combinations and make a selection

SORTING OPTIONS INCLUDE BY PRICE (LOWEST IS LISTED FIRST) OR BY MOTOR PERFORMANCE

Axi-dyne Sizing Results

Sort by Price Sort by Motor Performance

Matched Actuators (Sorted by List Price, Lowest First)

Actuator	Screw or Belt	Reduction	Ratio	Motor/Drive	Inertia Ratio	Torque Margin	%Difference
B3S10	SN02	LM	1	MRV21Y	8.16	2.14	0.00
B3S10	SN02	LM	1	MRV22Y	4.40	4.16	1.39
B3S10	SN02	RP2	2	MRV21Y	2.96	3.43	3.00
B3S10	SN02	RP1	1	MRV21Y	8.49	2.02	3.00
B3S10	SN02	LM	1	MRV23Y	3.05	5.88	3.50
B3S10	SN01	RP2	2	MRV21Y	8.38	2.48	4.31
B3S10	SN02	RP2	2	MRV22Y	1.58	6.57	4.38
B3S10	SN02	RP1	1	MRV22Y	4.58	3.93	4.38
B3S10	SN02	LM	1	MRV24Y	2.26	6.09	5.28
B3S10	SN01	RP2	2	MRV22Y	4.52	4.85	5.69
FctS10	SN02	RP2	2	MRV23Y	1.10	8.94	6.50

Note: An actuator must be selected. %Difference is the difference in price of currently selected actuator and lowest priced actuator sized.

Drive Options:
 Brushless
 Axides Drive

Last Actuator Chosen: B3S15 BN02 SH23.000 LM BM2 TM1 MRV31Y PV CRZ CR6

Axi-dyne® System Components and Selection

USING THE SIZING & SELECTION SOFTWARE

8. Generate application reports (save or print for reference)

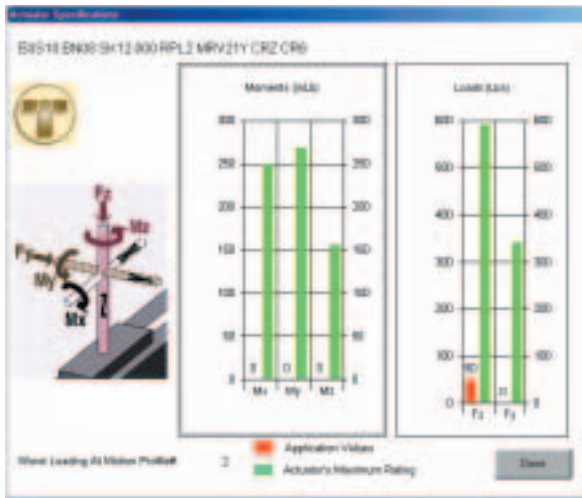

ACTUATOR SPECIFICATION WINDOW ALLOWS YOU TO VIEW MOMENTS AND FORCES OF THE APPLICATION'S VALUES VS ACTUATOR'S MAXIMUM RATING

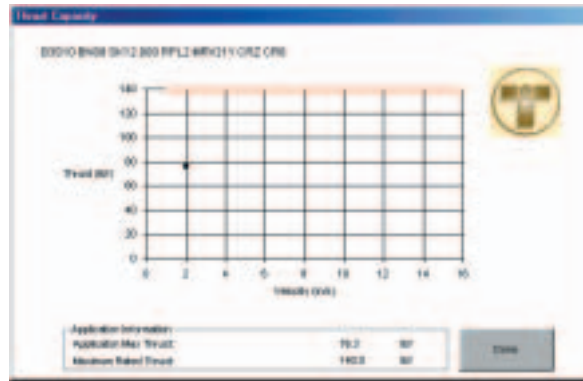

THRUST CAPACITY WINDOW SHOWS THE APPLICATION'S RATED THRUST VS MAXIMUM RATED THRUST OF A SYSTEM.

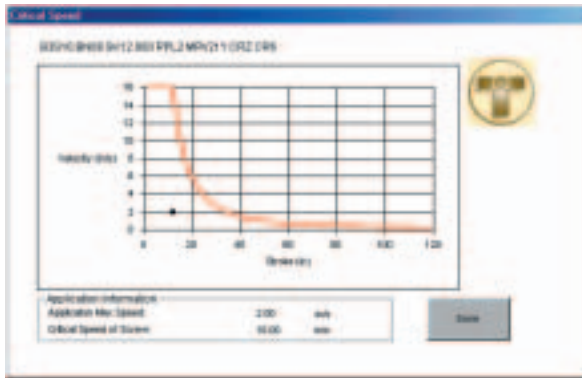

THE CRITICAL SPEED WINDOW SHOWS THE APPLICATION'S MAXIMUM SPEED, RELATIVE TO CRITICAL SPEED OF THE SCREW.

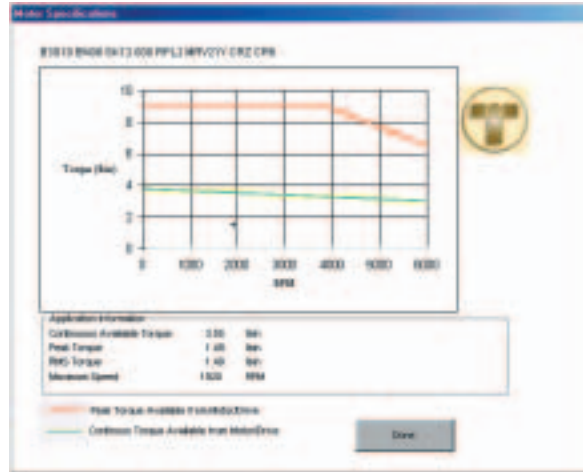

THE MOTOR SPECIFICATION WINDOW SHOWS HOW YOUR APPLICATION'S TORQUE COMPARES TO CONTINUOUS AND PEAK TORQUE.

8. Generate a sizing report to request a quote (save or print for reference)

TOL-O-MATIC, INC. EXCELLENCE IN MOTION

3000 County Road 116
 Bristol, NY 13310
 1-800-328-2174

Dist. by: 8/1/2012 10:27 PM

Customer: [Name], [Address], [City], [State], [Zip]

Quote Expires: 10/31/12

Configuration: BBS1H EN30 SH12 300 RPL3 MRV21Y CR2 CR6

Option	Description
BASE	SEVEN Series
EN30	Steel Nut, 2 mm post lock
MRV21	MRV21 Motor
CR2	Yellow Motor
CR6	Steel Nut & Flange - See Check Document
SW	Half Mount Stop Ring Switch - See Check Document
MRV21	MRV21 Servoless Motor
PL3	PL3 1.5 Axis Controller with two 16-bit Analog Inputs
CR2	CR2 Cable
CR6	4-meter Encoder and Motor Cable

EMAIL, FAX OR SEND TO TOL-O-MATIC OR YOUR AUTHORIZED TOLOMATIC REPRESENTATIVE

REPORT GENERATES THE COMPLETE CONFIGURATION STRING OF PRODUCT SELECTED

DESCRIPTION OF ALL CONFIGURED OPTIONS

PRODUCT OVERVIEW

Using Tol-O-Motion Sizing & Selection Software

- Application reports
- Sizing report

Axidyne® System Components and Selection

ACTUATOR CHOICE FLOW CHART

ACTUATOR BASICS

The flow chart at right is intended to provide some general comparisons to determine which actuator will work best for your application. Use the Tol-O-Motion™ sizing & selection software (available at www.tolomatic.com) to choose the exact Axidyne system for your needs. **Complete product features and performance information are included at the beginning of each product section.** The red bar graphs compare performance criteria of Tol-O-Matic actuators. *Longer red bars indicate higher numbers.*

AXIDYNE ACTUATORS ARE AVAILABLE IN TWO TYPES:

- 1) rod actuators (including GSA): featuring a rod that extends out of the actuator body, or
- 2) rodless actuators: featuring a carrier that moves along the length of the actuator body.

THRUST IS TRANSFERRED BY:

- 1) screw drive: featuring a rotating screw and an anchored nut (rod actuators are only available with screw drive), or
- 2) belt drive: featuring a belt anchored to the carrier that moves between pulleys at each end of the actuator.

SCREW AND NUT CHOICES:

- 1) Acme: featuring a solid nut of Delrin® or Bronze, or
- 2) Ball: featuring a recirculating ball bearing nut

PRODUCT OVERVIEW

Actuator Choice Flow Chart

- Rod actuators
 - RSA/RSM
 - GSA/GSM
- Rodless actuators
 - TKS
 - B3S/M3S
 - BCS/MCS
 - SLS/MLS
 - B3B/M3B
 - TKB

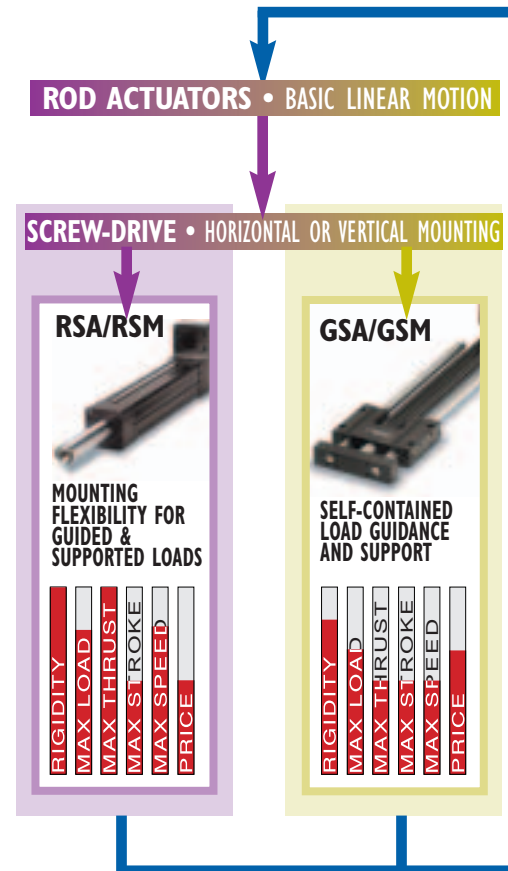

Axi-dyne® System Components and Selection

PRODUCT OVERVIEW

Actuator Choice Flow Chart

- Rod actuators
 - RSA/RSM
 - GSA/GSM
- Rodless actuators
 - TKS
 - B3S/M3S
 - BCS/MCS
 - SLS/MLS
 - B3B/M3B
 - TKB

ACTUATOR TYPE CHOICE • LINEAR ACTUATORS

RODLESS ACTUATORS • COMPACT SIZE, MOVEMENT WITHIN LENGTH OF ACTUATOR

SCREW-DRIVE • HORIZONTAL OR VERTICAL MOUNTING

BELT-DRIVE • HORIZONTAL MOUNTING

<p>TKS</p>  <p>SUPERIOR STRAIGHTNESS & FLATNESS</p> <p>RIGIDITY MAX LOAD MAX THRUST MAX STROKE MAX SPEED PRICE</p>	<p>B3S/M3S</p>  <p>HEAVY DUTY RECIRCULATING BEARING SYSTEM</p> <p>RIGIDITY MAX LOAD MAX THRUST MAX STROKE MAX SPEED PRICE</p>	<p>BCS/MCS</p>  <p>ADJUSTABLE CARRIER BRACKET, SELF LUBRICATING BEARING RODS</p> <p>RIGIDITY MAX LOAD MAX THRUST MAX STROKE MAX SPEED PRICE</p>	<p>SLS/MLS</p>  <p>RIGID, TORQUE RESISTANT, LOW PROFILE DESIGN</p> <p>RIGIDITY MAX LOAD MAX THRUST MAX STROKE MAX SPEED PRICE</p>	<p>B3B/M3B</p>  <p>HEAVY DUTY RECIRCULATING BEARING SYSTEM</p> <p>RIGIDITY MAX LOAD MAX THRUST MAX STROKE MAX SPEED PRICE</p>	<p>TKB</p>  <p>SUPERIOR STRAIGHTNESS & FLATNESS</p> <p>RIGIDITY MAX LOAD MAX THRUST MAX STROKE MAX SPEED PRICE</p>
--	---	---	---	--	--

SCREW & NUT CHOICE

ACME SCREW & NUT

QUIET OPERATION



BALL SCREW & NUT

LONG LIFE



MOTOR SYSTEM CHOICE (SEE NEXT PAGE)

Axi dyne[®] System Components and Selection

MOTOR SYSTEM CHOICE FLOW CHART

MOTOR SYSTEM BASICS

Application requirements of precision, repeatability and price will determine the type of motor system to choose. The flow chart at right is intended to provide some general comparisons to determine which Axidyne motor system will work best for your application. Use Tol-O-Motion sizing & selection software (available at www.tolomatic.com) to choose the exact Axidyne system for your needs. **Complete product features and performance information are included at the beginning of each product section.** The red bar graphs compare performance criteria of Tol-O-Matic motor systems. *Longer red bars indicate higher numbers.*

OPEN LOOP OR CLOSED LOOP

- 1) Open loop systems do not get position or velocity signals for correction and are typical in stepper systems.
- 2) Closed loop systems monitor encoder feedback and compare them to program commands, making corrections to eliminate error.

DRIVES AND CONTROLLERS

- 1) Axiom[®] Plus PV controller/drive for single-axis control, see features on page F-18.
- 2) MSS microstepping controller/drive for single-axis control, see features on page G-10.
- 3) MSC microstepping controller for single-axis control, see features on page H-13.
- 4) SSC multi-axis/multi-function servo/stepper controller, see features on pages F-25, G-13 or H-16.

Tol-O-Motion programming software is provided free of charge with any controller purchase. Check www.tolomatic.com for the latest upgrades.

USER INTERFACES

User interfaces provide the means to interact and monitor programs in use, eliminating the need for a computer following initial setup.

PRODUCT OVERVIEW

- Motor System Choice Flow Chart**
- Microstepping system

MOTOR SYSTEM CHOICE

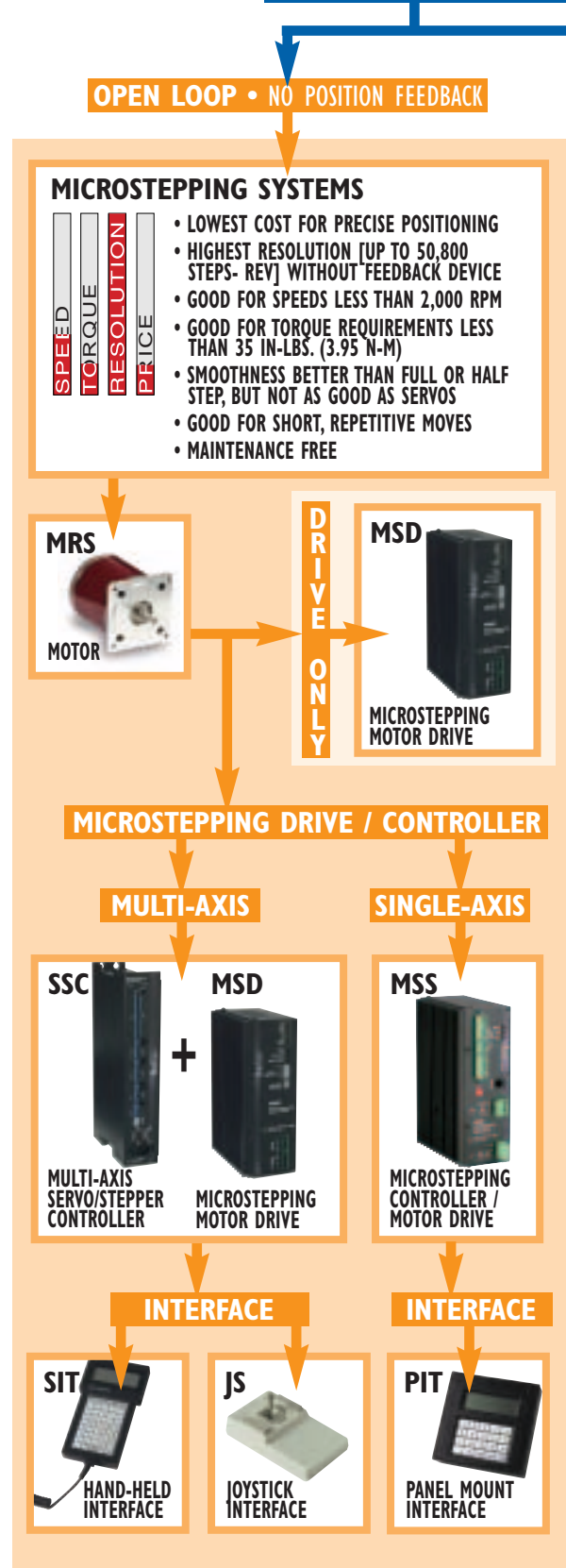

Axi-dyne® System Components and Selection

PRODUCT OVERVIEW

Motor System Choice Flow Chart

- Brushed dc systems
- Brushless servo systems

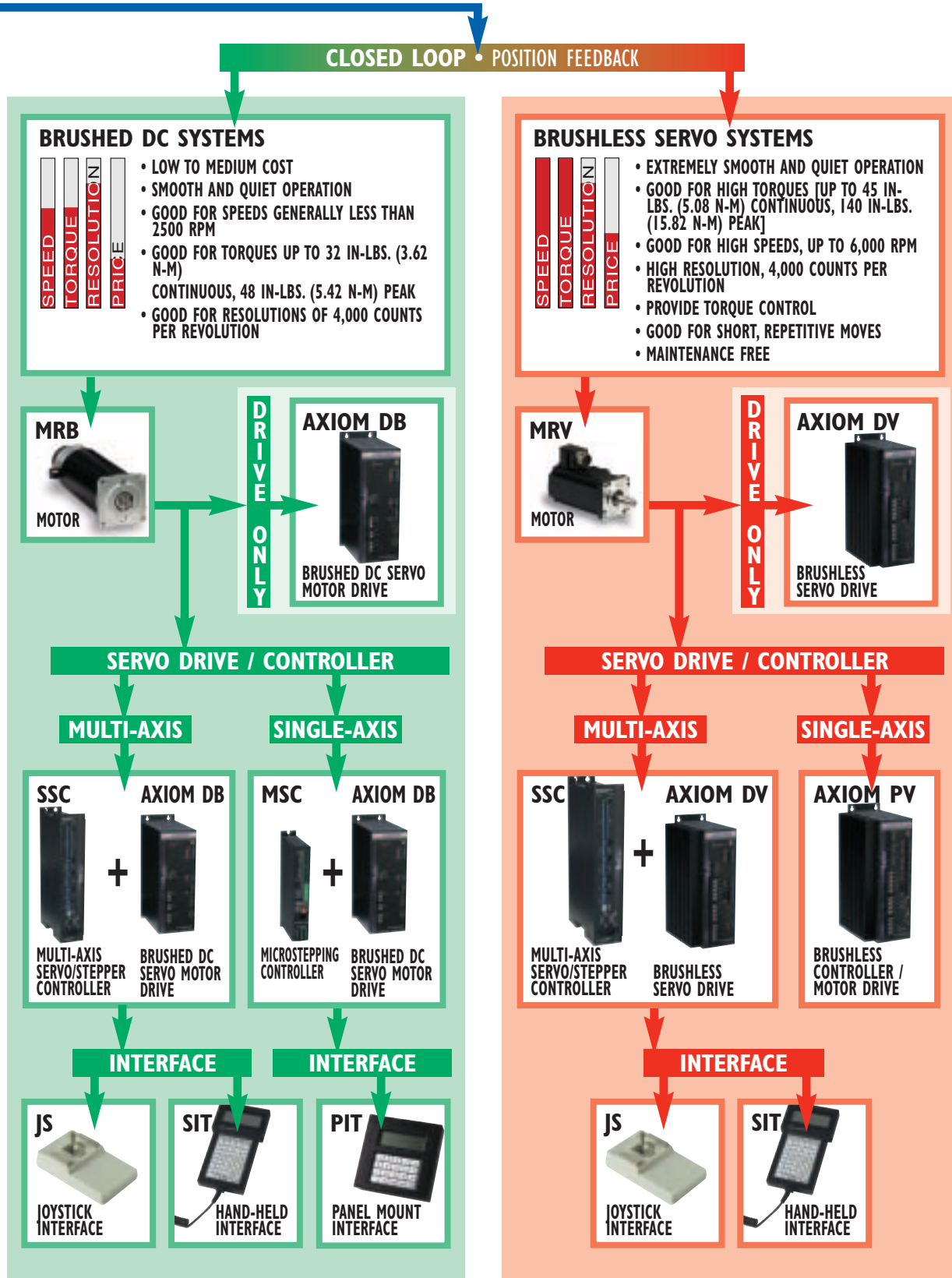

Axidyne[®] Actuator Series and Features

RODLESS ACTUATORS



PRODUCT OVERVIEW

Rodless Actuators

- TKS screw-drive actuators
- TKB belt-drive actuators

TRUTrack[™] TKS SCREW-DRIVE AND TKB BELT-DRIVE ACTUATORS

The TruTrack line of Axidyne actuators provides straighter, truer, linear motion (within 0.0002 inches per inch) than any other Tol-O-Matic actuator. The TruTrack guidance system uses ground linear rails and ball bearing blocks to decrease deflection and guide the carrier and its load. Choice of either lead screw or timing belt drive systems makes these actuators versatile enough to accommodate low/high thrust and speed applications where repeatability and low deflection are important.

- 4 compact overall envelope sizes ranging from 1.74 x 3 inches (44.2 x 76.2 mm) to 3.42 x 6.13 inches (86.9 x 155.6 mm)
- Screw-drive models available in 4 different screw sizes with acme or ball nut configurations
- Linear rails guide carrier for lowest deflection
- Ball screw or timing belt drive options for maximum flexibility
- Heavy-duty drive belts provide for greater thrusts and velocities
- System payloads ranging from 100 lbs (445 N) for the TK10 Series to 750 lbs (3338 N) for the TK75 Series.
- Multiple gearhead selections in gear ratios of 5.5:1 and 10:1
- Stroke lengths available in any incremental length ranging from 0 to 96 inches (2438 mm) depending on actuator type and body size
- Removable cover for rapid access to internal components and easy maintenance
- Internal sensing capability keeps wiring contained for clean, easy management
- Easy, secure mounting allows two axis configuration with adapter plates
- Internal motor coupling keeps package size compact
- Optional bellows cover helps keep contaminants out
- Matched with 8 different brushless servo motor selections in 17, 23, and 34 frame sizes.
- Matched with 5 different stepper motor selections in 17, 23 and 34 frame sizes.

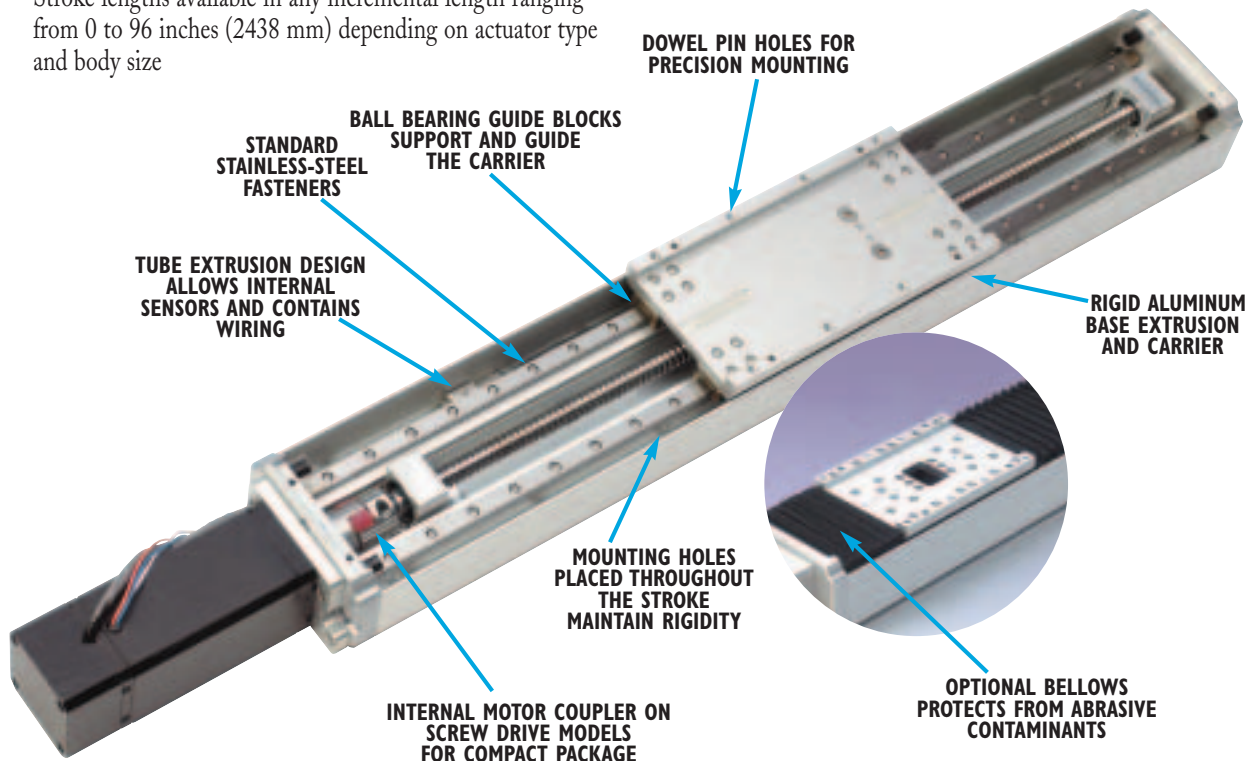

Axi-dyne® Actuator Series and Features

RODLESS ACTUATORS



PRODUCT OVERVIEW

- Rodless Actuators**
- B3S/M3S screw-drive actuators
 - B3B/M3B belt-drive actuators

B3S/M3S SCREW-DRIVE AND B3B/M3B BELT-DRIVE ACTUATORS

For high load and moment load capacity with consistent tracking, this series of actuators features a patented heavy duty recirculating bearing system in gothic arch rail guides. This system offers wear resistance with repeatable accuracy. Bearings are sealed for long wear and extended performance.

The B3S and B3B Series provide high load (over 2000 lbs) and moment capacity with consistent tracking for full actuator life.

B3S SCREW-DRIVE

- 3 body sizes
- Same envelope size as BCS actuators with higher load capacities
- Three english body sizes and 20 different screw/nut combinations.
- Three metric body sizes and 12 screw/nut combinations.
- Custom order strokes in any incremental length, up to 120 inches depending on screw selection.

B3B BELT-DRIVE

- 3 body sizes
- Neoprene belt material for higher speeds.
- Available 3:1 Reduction drive for matching motor speed and inertia.
- Custom-order stroke lengths, up to 292 inches in any incremental length. (For longer strokes, consult the factory.)

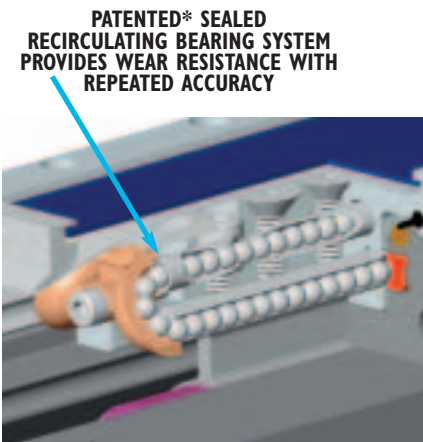

PATENTED* SEALED RECIRCULATING BEARING SYSTEM PROVIDES WEAR RESISTANCE WITH REPEATED ACCURACY

* U.S. PATENT NO. 5,555,789 ** U.S. PATENT NO. 4,545,290



UNIQUE LOAD BEARING CARRIER DESIGN RIDES ON THE BEARING RAILS FOR SMOOTH LOAD MOVEMENT WITH MINIMAL PLAY, RESULTING IN THE HIGHEST MOMENT RATINGS POSSIBLE

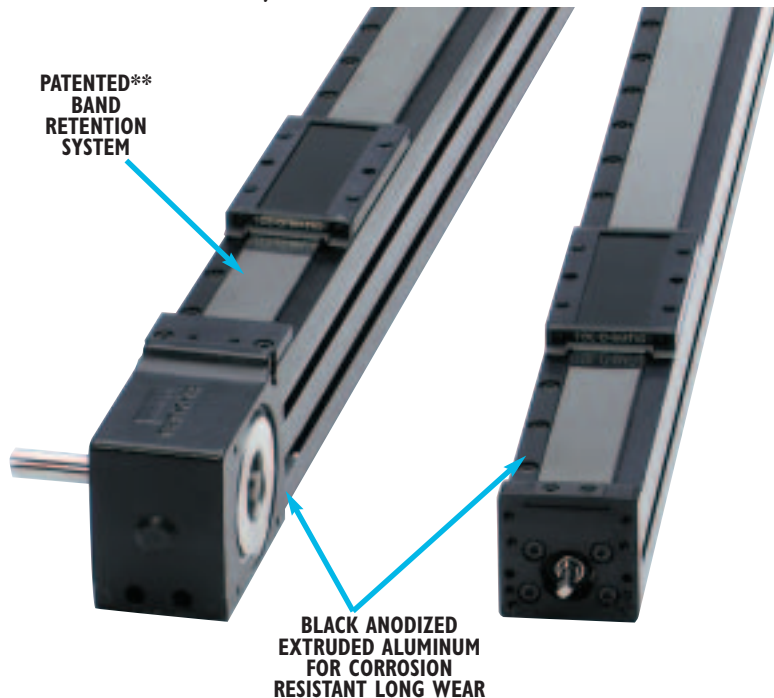

PATENTED BAND RETENTION SYSTEM**

BLACK ANODIZED EXTRUDED ALUMINUM FOR CORROSION RESISTANT LONG WEAR

PATENT-PENDING WEDGE DESIGN GUARANTEES THAT THE RACEWAYS ARE PARALLEL, WHICH INSURES CONSISTENT PRELOAD THROUGHOUT THE LENGTH OF THE CYLINDER

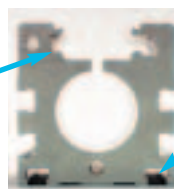

T-SLOT NUTS ARE PROVIDED FOR FLEXIBLE MOUNTING, ANYWHERE ALONG THE LENGTH OF THE ACTUATOR IN THE BOTTOM 2 RAILS. (4 NUTS ARE PROVIDED FOR THE FIRST 24 INCHES OF STROKE. 2 MORE FOR EACH ADDITIONAL 20 INCHES OF STROKE.)

Axi-dyne® Actuator Series and Features

RODLESS ACTUATORS



PRODUCT OVERVIEW

Rodless Actuators

- SLS/MLS screw-drive actuators
- BCS screw-drive actuators

SLS/MLS & BCS/MCS SCREW-DRIVE ACTUATORS

SLS/MLS SCREW-DRIVE ACTUATOR

These pre-engineered, load-supporting and fully enclosed slide-style actuators use a guidance system of recirculating bearings on ground steel shafts providing consistent carrier tracking and long actuator life. Using the same patented band retention system as the BCS style actuators, SLS actuators are available in one body size and offer a rigid, low-profile design, ideal for space-sensitive applications.

- Extruded work table, fully extruded anodized-aluminum work table has two parallel "T" slots for mounting flexibility and stability.
- Single-piece housing, fully extruded anodized aluminum housing increases stability and provides continuous bearing rod support along full stroke.
- One english body size and four screw/nut combinations with anti-backlash option.
- One metric body size and three screw/nut combinations
- Custom-order strokes in any incremental length, up to 72 inches.

BCS/MCS SCREW-DRIVE ACTUATOR

This group of actuators utilizes a guidance system consisting of a patented adjustable carrier bracket designed to transmit the load to the cylinder body instead of the screw or belt for true tracking, superior load support and controlled minimum friction load. The load-bearing carrier system uses two self-lubricating Delrin bearing rods to pass force directly to the cylinder tube. A patented band retention system uses a T-shaped elastomer strip bonded to a stainless steel band inserted directly into the body housing forming a tight metal-to-metal seal.

BCS Screw-Drive

- Three english body sizes and 12 screw/nut combinations.
- Three metric body sizes and 12 screw/nut combinations.
- Custom-order strokes in any incremental length, up to 120 inches.

*U.S. PATENT NO. 4,724,744
 **U.S. PATENT NO. 4,545,290
 ***U.S. PATENT NO. 4,852,465

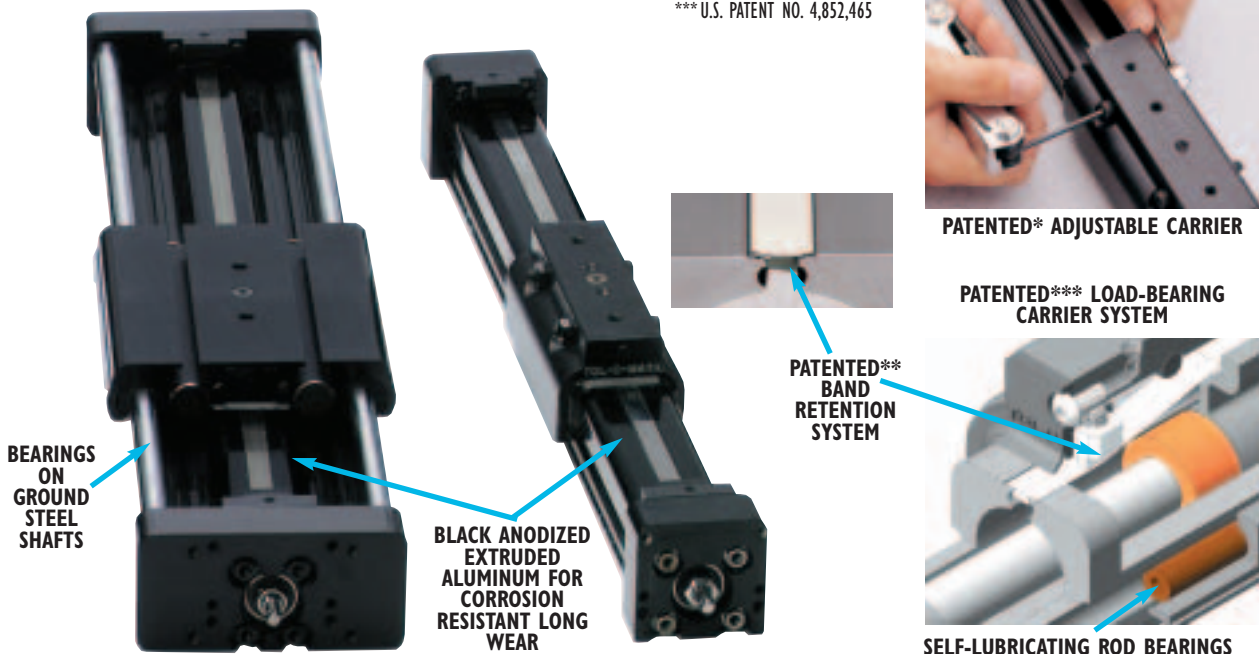

BEARINGS ON GROUND STEEL SHAFTS

BLACK ANODIZED EXTRUDED ALUMINUM FOR CORROSION RESISTANT LONG WEAR

PATENTED** BAND RETENTION SYSTEM

PATENTED* ADJUSTABLE CARRIER

PATENTED*** LOAD-BEARING CARRIER SYSTEM

SELF-LUBRICATING ROD BEARINGS

Axidyne[®] Actuator Series and Features

ROD STYLE ACTUATORS



RSA/RSM

GSA/GSM

PRODUCT OVERVIEW

Rod Actuator

- RSA/RSM rod screw actuator

RSA/RSM ROD SCREW ACTUATOR

The Axidyne family of rod screw actuators offers the most complete selection of sizes, options and system components. Designed with high performance, high thrust, dependability and mounting flexibility in mind, these actuators easily combine with our other motion control components in brushless servo, microstepping or brushed dc system configurations. Together, they offer a cost-competitive solution for a multitude of motion control applications.

- 6 different body sizes ranging from .75-inch (19mm) to 4-inch (100mm) body sizes.
- 5 different screw sizes ranging from .375-inch to 1.5-inches with either solid or ball nut configuration.
- System thrust capabilities ranging from 70 lbs (311.4N) for the RSA/RSM12 Series to 7000 lbs (31,138N) for the RSA/RSM64 Series.
- 8 different brushless servo motor selections in 17, 23 and 34 frame sizes.
- 6 different stepper motor selections in 17, 23 and 34 frame sizes.
- 5 different brushed dc motor selections in 23, 34 and 4-inch frame sizes.
- 7 different gearhead selections in gear ratios of 5.5:1 or 10:1.
- Stroke lengths available in any incremental length ranging from 0 to 60 inches depending on actuator body size.
- Magnets (for use with either dc reed, Hall-effect or ac Triac switches) come standard on all four sides of the actuator for greater mounting flexibility.
- Conforms to both NFPA and ISO industry mounting standards.

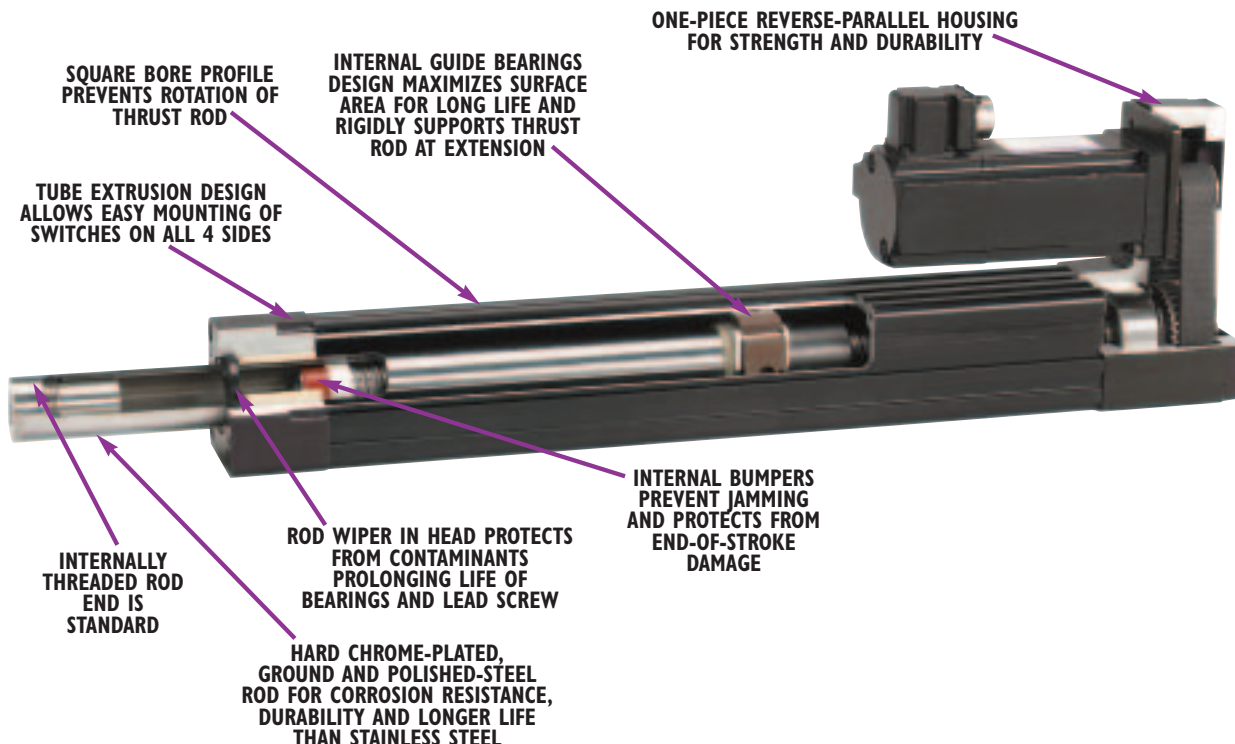

Axi^{dyne}® Actuator Series and Features

GUIDED ROD STYLE ACTUATORS

PRODUCT OVERVIEW

Rod Actuator

- GSA/GSM guided rod screw actuator



GSA/GSM GUIDED ROD SCREW ACTUATOR

The Axidyne family of guided screw actuators combines rod screw actuators with mounting block, guide rods and bearings based on Tol-O-Matic's extensive experience with pneumatically guided actuators. The GSA/GSM offers a complete selection of sizes, options and system components. Designed with high performance, dependability and mounting flexibility in mind, these actuators easily combine with any of our motion control system components in brushless servo, microstepping or brushed dc system configurations. Together, they offer a cost-competitive solution for a multitude of motion control applications.

- Four english and metric body sizes ranging from .75-inch (19mm) to 2-inch (50mm) with in line or reverse parallel motor configuration.
- Fifteen english screw/nut combinations and screw sizes ranging from .375-inch to .750 -inches with either solid Acme (plastic or bronze) or ball nut configuration.
- System thrust capabilities ranging from 70 lbs (311.4N) for the GSA/GSM12 Series to 2700 lbs (12,010N) for the GSA/GSM32 Series.
- Choice of linear ball or composite bearings with internal lubrication of guide rods for increased life of bearings.
- Standard or oversize guide rod diameter for increased rigidity and lower deflection
- 8 different brushless servo motor selections in 17, 23 and 34 frame sizes.
- 6 different stepper motor selections in 17, 23 and 34 frame sizes.
- 5 different brushed dc motor selections in 23, 34 and 4-inch frame sizes.
- 6 different gearhead selections in gear ratios of 5.5:1 or 10:1.
- Stroke lengths available in any incremental length ranging from 0 to 36" (914mm) depending on actuator body size.
- Available with the widest range of options including stop collars, stainless-steel guide rods, adapter plates and switches: dc Reed, Hall-effect or ac Triac.

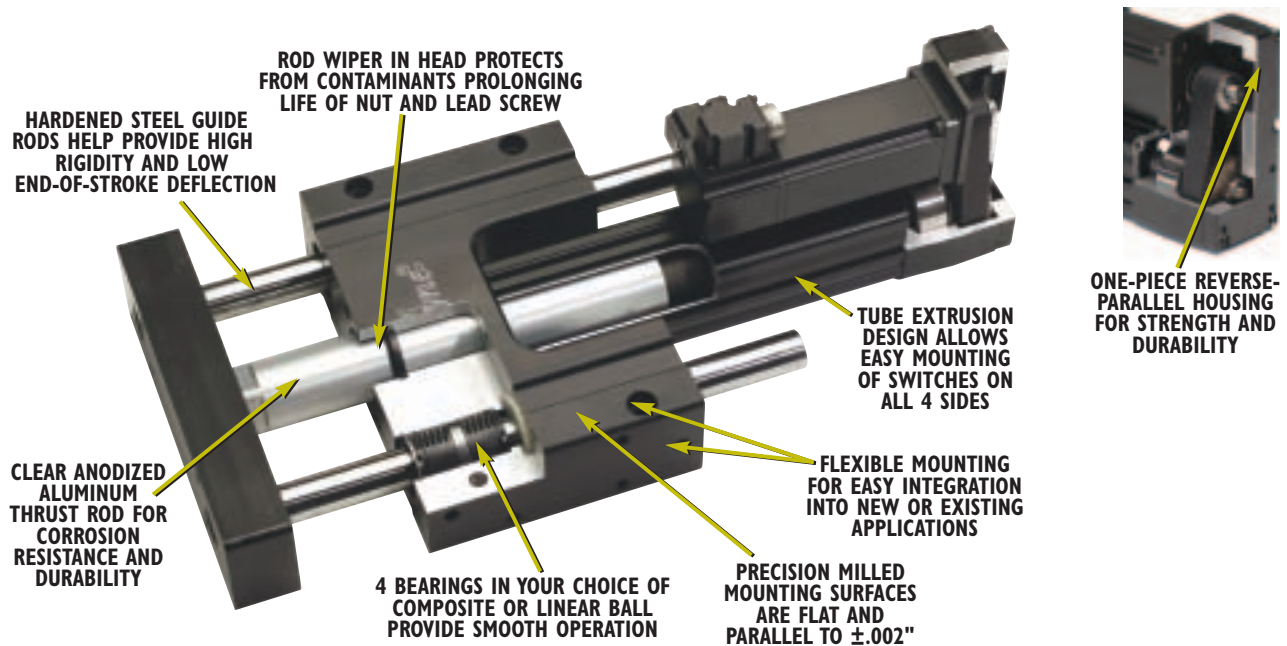

BRUSHLESS SERVO SYSTEM - MOTORS, DRIVES AND CONTROLS

MRV, AXIOM® DV, AXIOM® PV, SSC, JS, SIT

PRODUCT OVERVIEW

Brushless Servo System

- Motors
- Drives
- Controls

MRV - BRUSHLESS SERVO MOTORS

- Rugged, with large shafts and bearings, IP65
- Convenient MS connectors
- Common flanges (NEMA 17, 23, 34 and 56)
- Integral temperature switch and 1000 line encoder

AXIOM® DV - BRUSHLESS SERVO DRIVE

- Designed to drive MRV motors
- Peak current ratings of 10A, 20A and 30A
- State-of-the-art vector commutation and current control for efficient high-bandwidth servo performance
- Simple Windows®-based software for set-up and installation

AXIOM® PLUS PV CONTROLLER/DRIVE:

- Combines into one unit:
 - PLC: with real-time scan, 175 rung ladder logic
 - Motion Controller: with 1 to 1.5 axis, event triggering, motion pause and resume, point & click editor
 - AXIOM drive: with all features listed above
- Includes Tol-O-Motion™ Axiom Motion Control Software and intuitive point and click sequential program and PLC ladder logic editors

SSC CONTROLLER:

- Performs any motion task including jogging, point-to-point positioning, linear and circular interpolation, electronic gearing, camming and contouring
- Multitasking feature permits simultaneous execution of four independent applications programs
- Tol-O-Motion SSC Motion Control Software allows setup & programming with easy-to-use Windows® interface
- Up to 4 axes per unit - up to 4 units can be daisy-chained
- 4M non-volatile EEPROM memory for executing custom application programs - permits stand-alone operation
- Relative and absolute positioning with more than ± 2,000,000,000 counts per move
- Inputs: opto-isolated dedicated for home, abort, forward and reverse limits, 8 uncommitted; 7 analog inputs
- Outputs: 8 programmable

JS - JOYSTICK INTERFACE

- Use with SSC joystick teach mode

SIT - HAND-HELD INTERFACE

- 45 key - keypad, LCD display

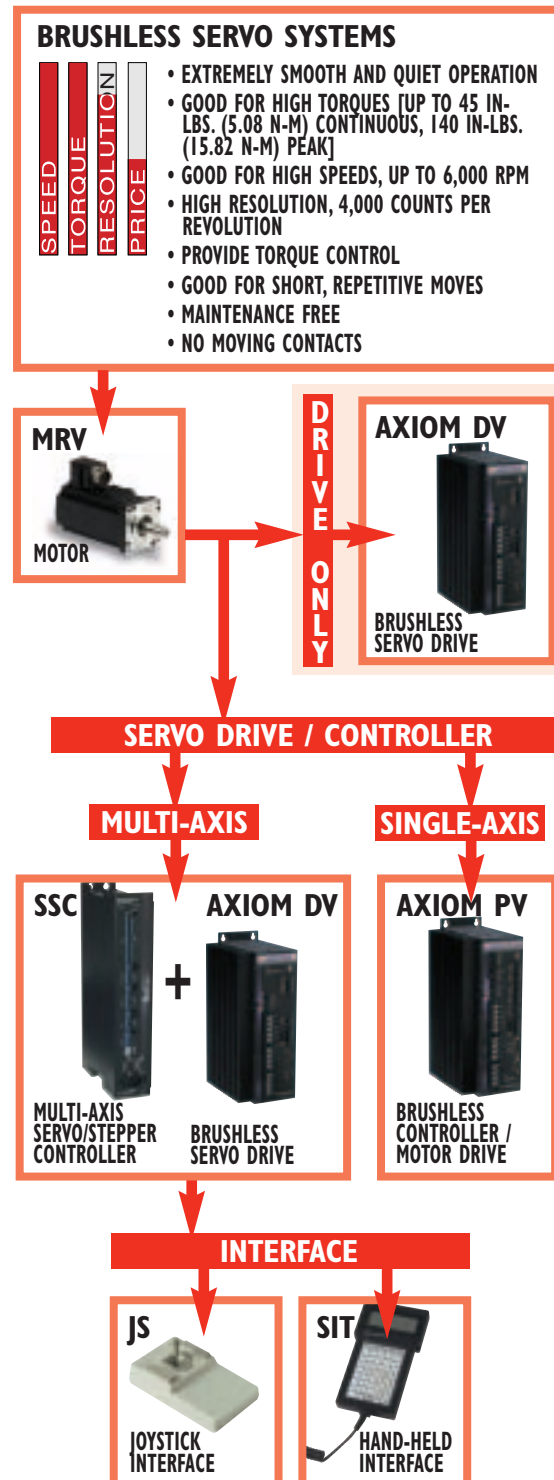

MICROSTEPPING SYSTEM - MOTORS, DRIVES AND CONTROLS

MRS, MSD, MSS, SSC, PIT, JS, SIT

MRS - STEPPER MOTORS

- High torque to inertia ratio
- Long life bearings, high temperature insulation and exceptional thermal dissipation
- NEMA 17, 23 and 34 mounting

MSD MICROSTEPPING DRIVE

- Step, direction, amplifier enable inputs, fault output, optically isolated
- 16 switch selectable microstepping resolutions
- Idle current reduction (50% switch selectable)

MSS CONTROLLER/DRIVE:

- Combines basic single axis controller and drive
- Software uses intuitive icons for setup & programming
- Software selectable: resolutions, motor current
- Two dedicated, optically isolated limit switch inputs, Four general purpose, opto-isolated inputs, CW and CCW jog inputs
- Drive fault output, 3 general purpose, optically isolated outputs

SSC CONTROLLER:

- Performs any motion task including jogging, point-to-point positioning, linear and circular interpolation, electronic gearing, camming and contouring
- Multitasking feature permits simultaneous execution of four independent applications programs
- Tol-O-Motion SSC Motion Control Software allows setup & programming with easy-to-use Windows® interface
- Up to 4 axes per unit - up to 4 units can be daisy-chained
- 4M non-volatile EEPROM memory for executing custom application programs - permits stand-alone operation
- Relative and absolute positioning with more than $\pm 2,000,000,000$ counts per move
- Inputs: opto-isolated dedicated for home, abort, forward and reverse limits, 8 uncommitted; 7 analog inputs
- Outputs: 8 programmable

PIT - PANEL MOUNT USER INTERFACE

- Keypad, LCD display for use with MSS

JS - JOYSTICK

- Use with SSC joystick teach mode

SIT - HAND-HELD INTERFACE

- 45 key - keypad, LCD display for use with SSC

PRODUCT OVERVIEW

Microstepping System

- Motors
- Drives
- Controls

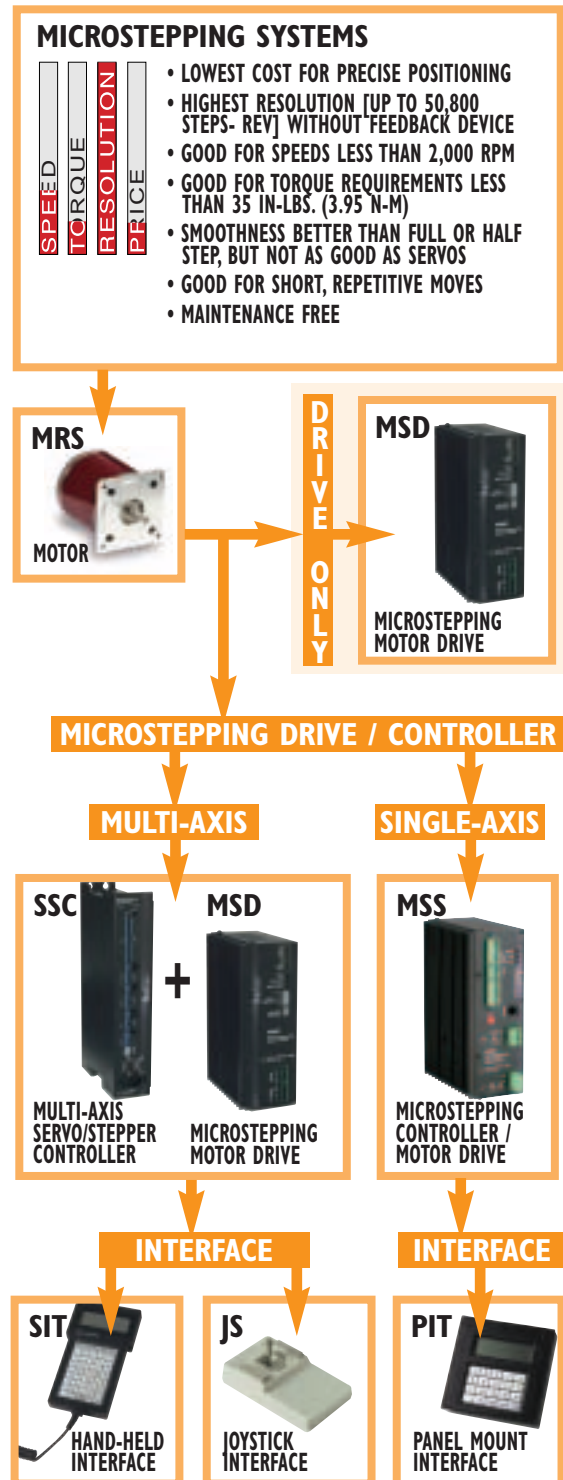

BRUSHED DC SERVO SYSTEM - MOTORS, DRIVES AND CONTROLS

MRB, AXIOM® DB, MSC, SSC, PIT, JS, SIT

MRB - BRUSHED DC MOTORS

- 1,000 line optical encoder available for servo operation
- NEMA 17, 23 and 34 mounting

AXIOM® DB - BRUSHED DC SERVO DRIVE

- Peak current ratings of 20A
- Simple Windows®-based software
- Excellent performance and accuracy at high speeds
- Optically isolated inputs: dedicated CW/CCW travel limit; drive enable, step/direction and step CW/step CCW
- Optically isolated outputs

MSC CONTROLLER:

- Software icons for intuitive setup & programming
- Built-in power supplies: 24 Vdc, 100mA is provided for the user for sensors and I/O circuits.
- Optically isolated inputs: 4 dedicated, CW and CCW jog, 2 limits; 4 general purpose
- Optically isolated outputs: drive fault output; 3 general purpose; differential step and direction outputs
- Programmable resolution to match encoder

SSC CONTROLLER:

- Performs any motion task including jogging, point-to-point positioning, linear and circular interpolation, electronic gearing, camming and contouring
- Multitasking feature permits simultaneous execution of four independent applications programs
- Tol-O-Motion SSC Motion Control Software allows setup & programming with easy-to-use Windows® interface
- Up to 4 axes per unit - up to 4 units can be daisy-chained
- 4M non-volatile EEPROM memory for executing custom application programs - permits stand-alone operation
- Relative and absolute positioning with more than ± 2,000,000,000 counts per move
- Inputs: opto-isolated dedicated for home, abort, forward and reverse limits, 8 uncommitted; 7 analog inputs
- Outputs: 8 programmable

PIT - PANEL MOUNT USER INTERFACE

- Keypad, LCD display for use with MSC

JS - JOYSTICK INTERFACE

- Use with SSC joystick teach mode

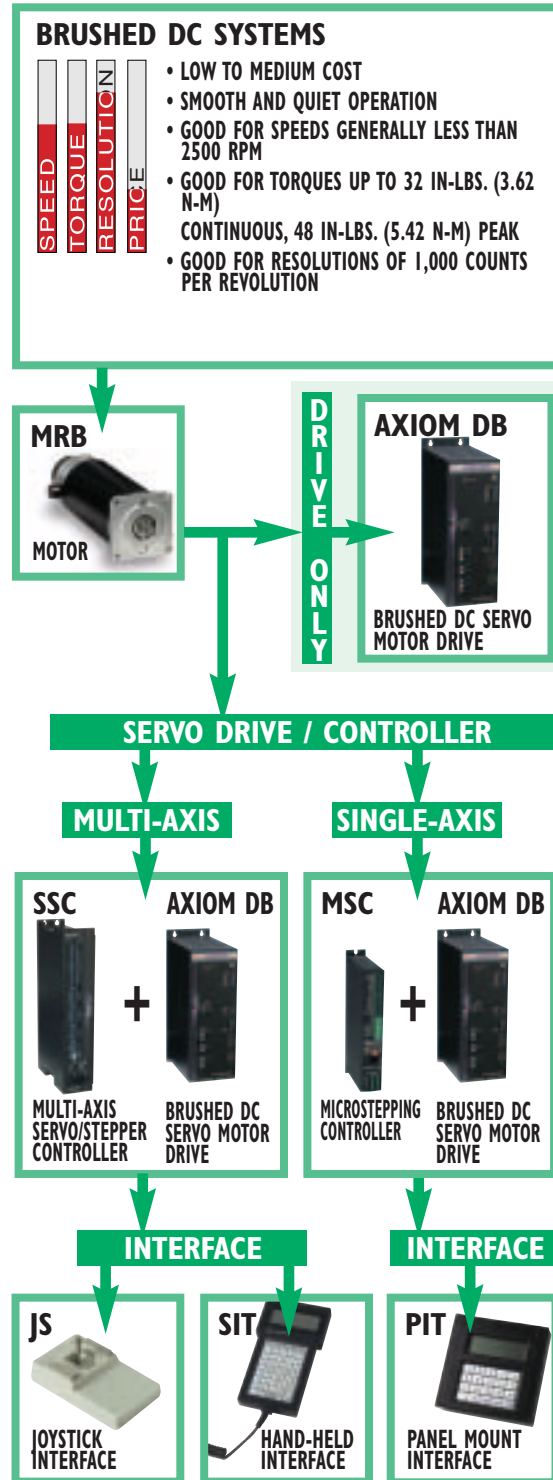

SIT - HAND-HELD INTERFACE

- 45 key - keypad, LCD display for use with SSC

PRODUCT OVERVIEW

Brushed dc Servo System

- Motors
- Drives
- Controls

Axi dyne® Electric Linear Motion Systems

ON THE WEB AT www.tolomatic.com

PRODUCT OVERVIEW

Axidyne System Components
• www.tolomatic.com

Our web site is your definitive source for Tol-O-Matic information. This database driven site has the most up-to-date literature, product information, CAD files, distributor information... everything you want to know about Tol-O-Matic.

The screenshot shows the Tol-O-Matic website interface. At the top, there is a navigation bar with links for PRODUCTS, CONTACT US, COMPANY INFO, HOW TO BUY, LITERATURE, TECH SUPPORT, and SITE TOOLS. Below this, a main content area features a central banner for 'Your Automation Component S...' with a list of products: Pneumatic Actuators, Axidyne Electric Linear Motion Co..., Servo-Driven Welding, Gearboxes, Brakes, Clutches, and NEW! Slide-Rite Gearbox. To the right of this banner is a 'Drop down navigation' menu with options like Catalogs, Brochures, Part Sheets, User Manuals, Tech Bulletins, White Papers, Press Releases, and Articles. Below the main content, there are sections for 'APPLICATIONS' (featuring a video thumbnail of a conveyor design), 'motion control' (with a video thumbnail), and 'IN THE NEWS...' (with a 3D CAD model thumbnail). At the bottom, there is a footer with contact information (Phone: 763.478.8000 • Toll Free: 1.800.328.2174), a navigation bar, and the Tol-O-Matic logo with the tagline 'Excellence in Motion®'. Three red callout arrows point to specific features: one to the product list, one to the drop-down menu, and one to the 3D CAD model thumbnail.

Check here for new and featured products

Drop down navigation allows you to quickly drill down to the product, or information you desire.

Exciting application examples featuring innovative product use, often with streaming video footage.

Click here for 3D and 2D CAD files

Axi *dyne*[®] Rodless Actuator Technical Data



B3S/M3S SCREW DRIVE ACTUATORS
B3B/M3B BELT DRIVE ACTUATORS



TruTrack TKS SCREW DRIVE ACTUATORS
TruTrack TKB BELT DRIVE ACTUATORS



RODLESS



BCS/MCS SCREW DRIVE ACTUATORS

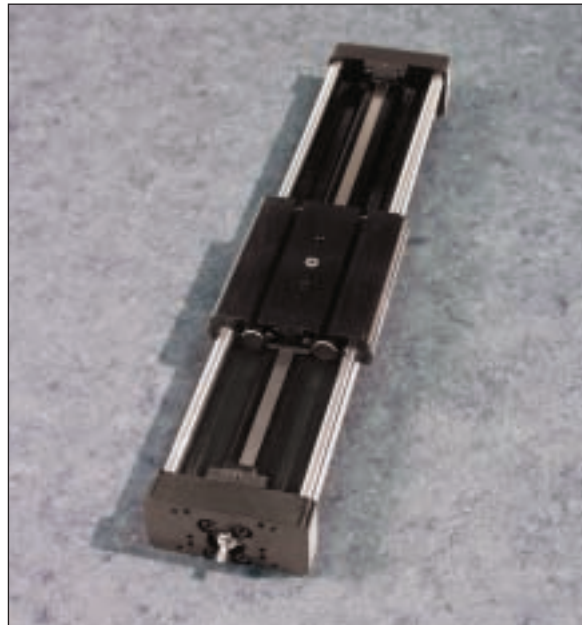

SLS/MLS SCREW DRIVE ACTUATORS

The following pages contain detailed information about Tol-O-Matic rodless actuators. Visit www.tolomatic.com for the latest updates, CAD files and software support downloads.



Axi-dyne® B3S/M3S Screw Drives

APPLICATION BENEFITS

- Accommodate heavy loads
- Handle high moment loads with consistent, smooth operation
- Cost-effective alternative to auxiliary rail systems
- Consistent work point deflection through life of product
- 100% duty cycle

BEARING SYSTEM



- Heavy duty recirculating bearings in gothic arch rail guide.
- Wear resistance with repeatable accuracy
- Patented* sealed bearing system—for long life
- High load and moment capacities
- Consistent tracking for full actuator life

STANDARD MOUNTING



- B3S actuators have T-nut mounting in the body base with four T-nuts for the first 24 inches of stroke. Two nuts are provided for each additional 20 inches.

ACTUATOR/MOTOR FACTORS

- Actuator's operating temperature range (40-130° F, 4-54° C) should take into consideration heat generated by the motor and drive, linear velocity and work cycle time.
- For large frame motors or small actuators, cantilevered motors need to be supported, if subjected to continuous rapid reversing duty and/or under dynamic conditions.

AVAILABLE OPTIONS



Tube Supports: Provide intermediate support of actuator body at the recommended intervals.



Auxiliary Carrier: Increases rigidity, load-carrying capacity and bending moments.

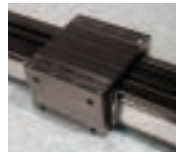

Dual 180° Carrier: Allows load to be rotated 90° from the cylinder's carrier, providing an additional load bearing surface. Requires its own proprietary tube supports and foot mounts.



Auxiliary Dual 180° Carrier: Substantially increases loads and moments.



Mounting Plates: Provide clearance height for motors and motor mounts when mounting an actuator on a flush surface and provide the means for top mounting access. Kits include plates and mounting screws.



Motor Mounting and Gearhead Reduction:

In-line Motor Mounting—This motor mounting option uses a spacer and coupler to join the motor to the actuator shaft.



Reverse-parallel Motor Mounting—These factory assembled configurations allow offset mounting of the motor to either side of, or below the actuator. Available in 1:1 or 2:1 drive ratios, they offer quiet, zero-backlash coupling of the motor to the actuator screw shaft.



Gearhead Reduction—Gearheads are available for applications requiring reduction for inertia matching or higher torque at lower speeds. High efficiency, single stage, true planetary gearheads are available in 5.5:1 and 10:1 ratios for reduction solutions with most Tol-O-Matic NEMA 23 and 34 face motors. For gearhead specifications and dimensions, see page F-10.



Switches: Reed, dc Hall-effect and ac TRIAC. See page I-1.

* U.S. Patent No. 5,555,789

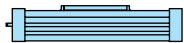

RODLESS

B3S Screw Drive

- Application Benefits
- Bearing System
- Standard Mounting
- Actuator/Motor Factors
- Available Options

Axi-dyne® B3S/M3S Screw Drives

ACME SCREW/NUT COMBINATIONS

ACME SCREW CRITICAL SPEED CAPACITIES

CRITICAL SPEED WITH ENGLISH ACME SCREW

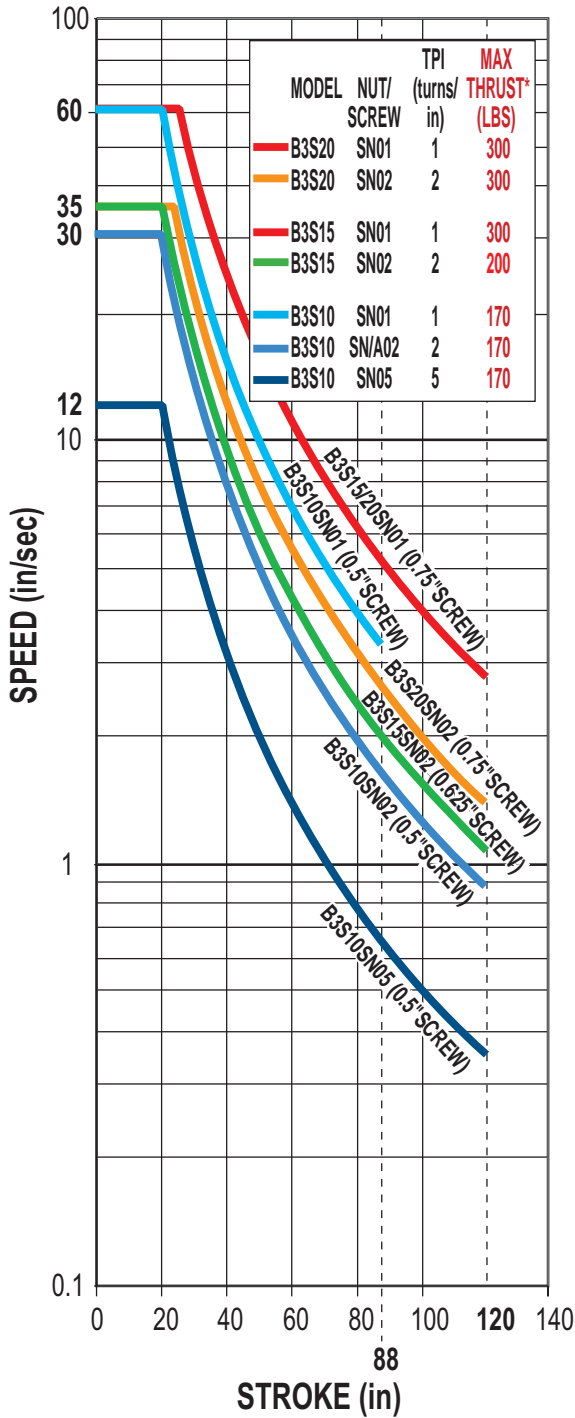

CRITICAL SPEED WITH METRIC ACME SCREW

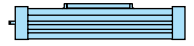
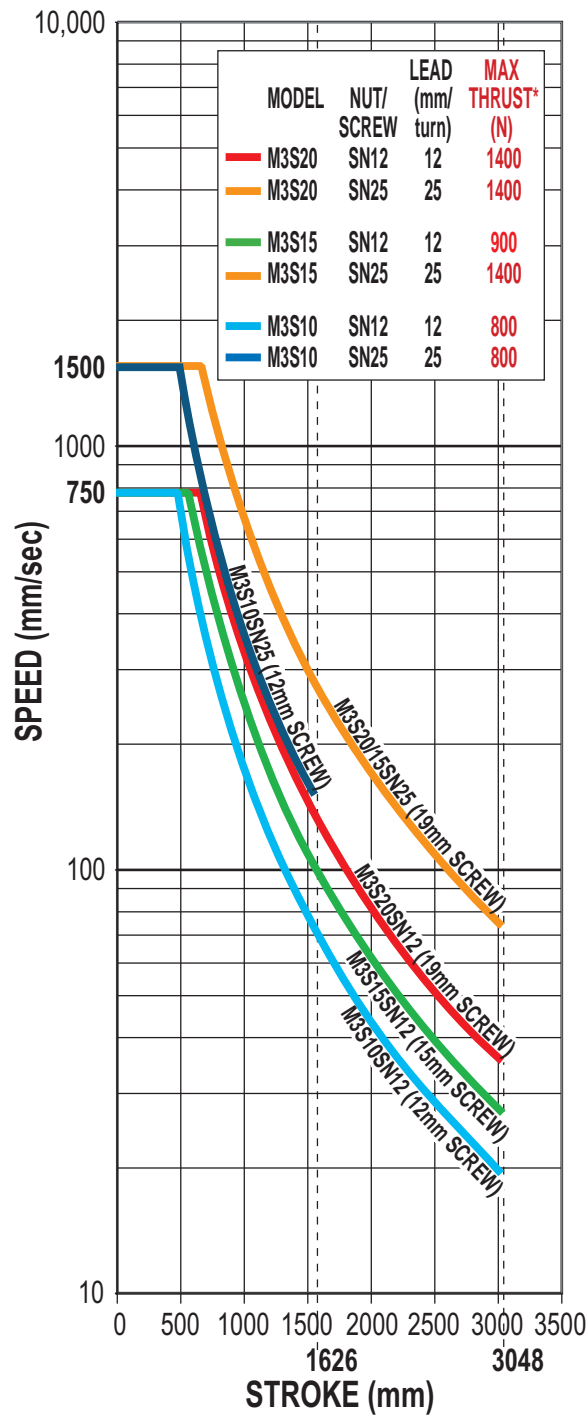

RODLESS

B3S/M3S Series

- Acme screw/nut combinations
- Screw critical speed capacities



* Maximum thrust is the maximum continuous dynamic thrust subject to Thrust x Velocity limitation.

Dotted lines represent maximum stroke for screw selections.

For Screw PV limits, refer to the individual charts located in the technical section for each actuator body size.

SCREW CODE	DESCRIPTION
SN	Solid Nut
SNA	Anti-backlash Solid Nut

Axi-dyne® B3S/M3S Screw Drives

BALL SCREW/NUT COMBINATIONS

BALL SCREW CRITICAL SPEED CAPACITIES

CRITICAL SPEED WITH ENGLISH BALL SCREW

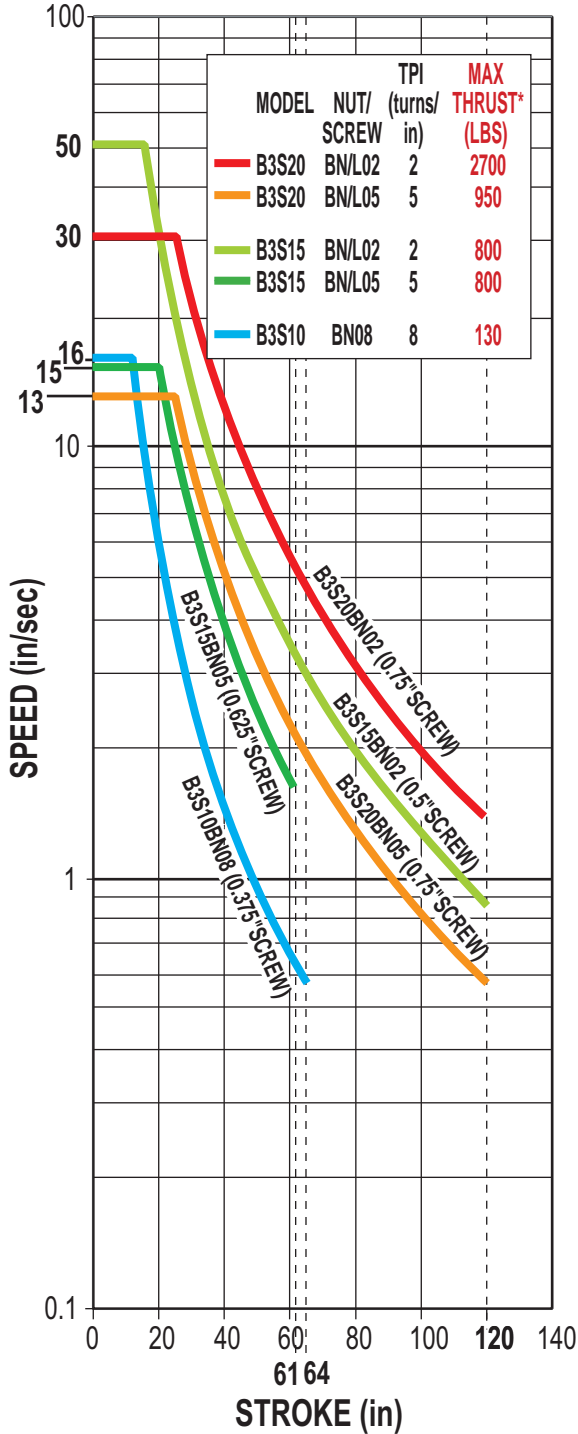

CRITICAL SPEED WITH METRIC BALL SCREW

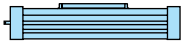
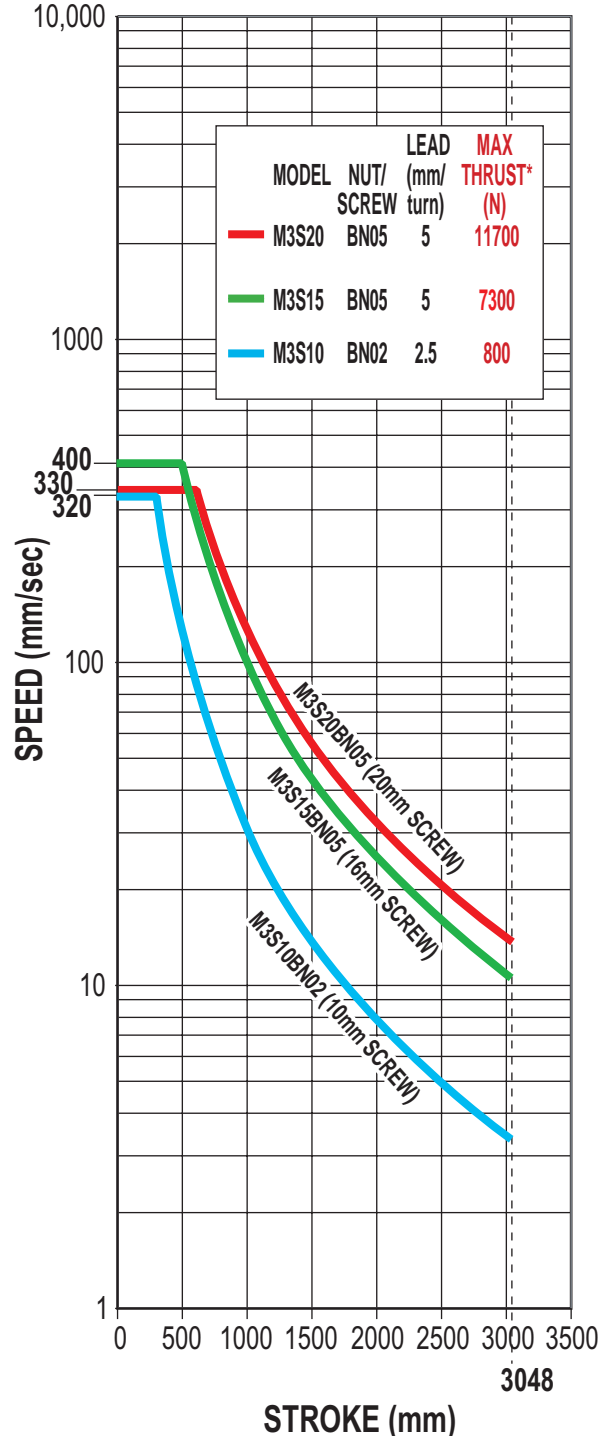

RODLESS

B3S/M3S Series

- Ball screw/nut combinations
- Ball screw critical speed capacities



* Maximum thrust reflects 90% reliability for 1 million linear inches of travel.

Dotted lines represent maximum stroke for screw selections.

SCREW CODE	DESCRIPTION
BN	Ball Nut
BNL	Low-Backlash Ball Nut

Axi-dyne® B3S/M3S Screw Drives

BALL SCREW/NUT COMBINATIONS

BALL SCREW LIFE CALCULATIONS

LIFE CAPACITIES WITH ENGLISH BALL SCREW

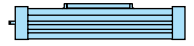
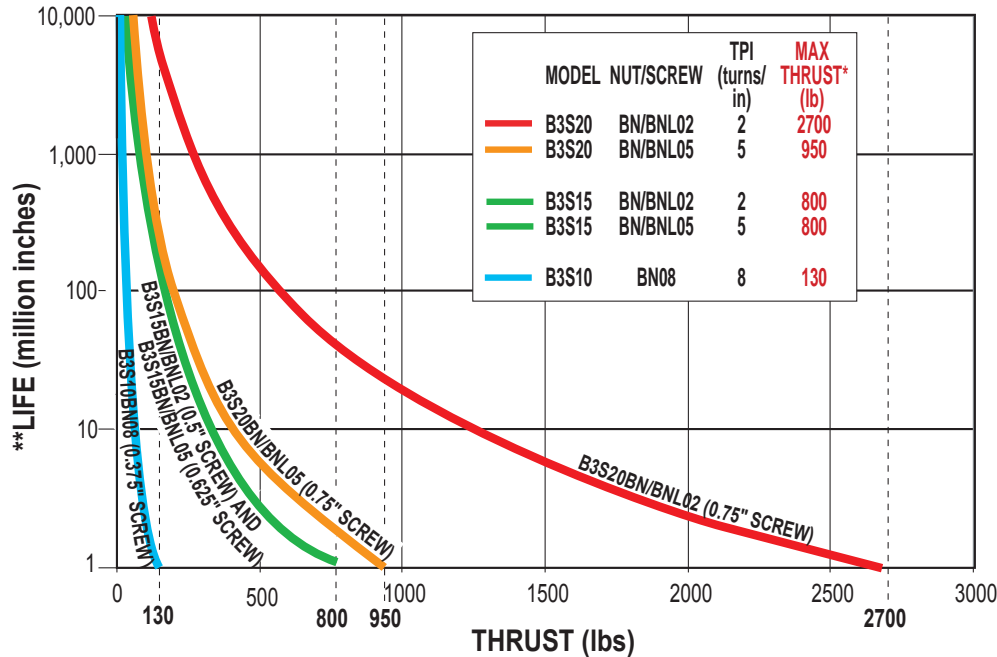

RODLESS

B3S/M3S Series

- Ball screw life calculations

LIFE CAPACITIES WITH METRIC BALL SCREW

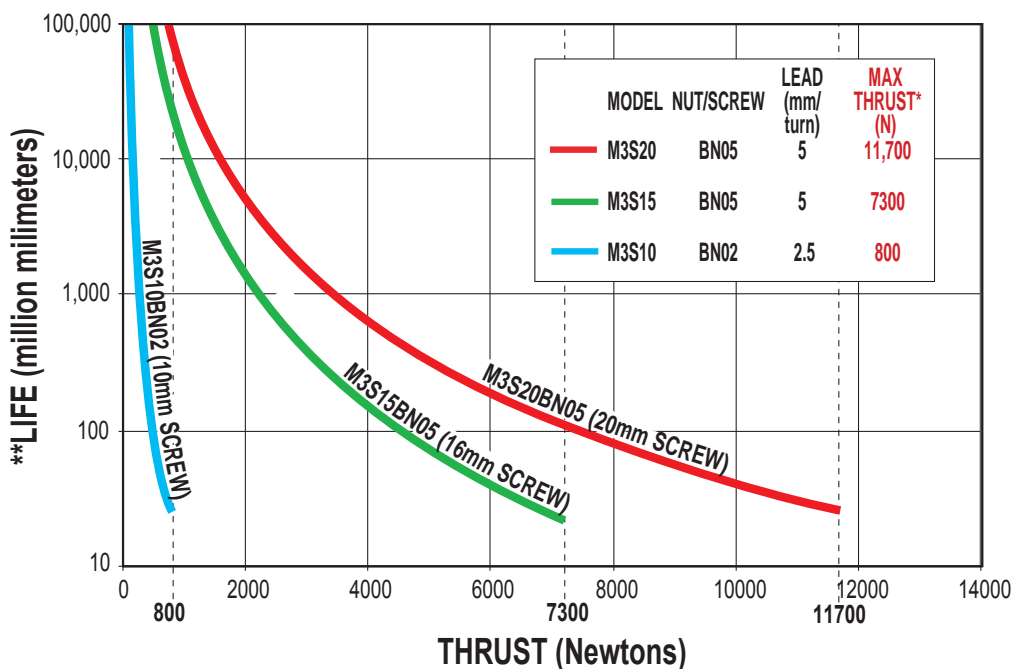

! * Maximum thrust reflects 90% reliability for 1 million linear inches of travel.

Dotted lines represent maximum thrust for screw selections.

**Life indicates theoretical maximum life of screw only, under ideal conditions and does not indicate expected life of actuator.

Axi-dyne® B3S/M3S Screw Drives

OVERALL SERIES SPECIFICATIONS

SPECIFICATIONS RELATED TO ACTUATOR SIZE AND SCREW SELECTION



RODLESS

B3S/M3S Series

• Actuator/screw specifications

ENGLISH LEAD SCREWS											
ACTUATOR SERIES	SCREW DIA. (in)	SCREW TYPE	TPI (turns/in)	LEAD ACCURACY (in/ft)	BACKLASH (in)	MAXIMUM THRUST* (lb)	MAXIMUM STROKE (in)	INERTIA (lb-in ²)			BREAKAWAY TORQUE (lb-in)
								BASE ACTUATOR		PER/in OF STROKE	
								In Line	Rev. Parallel		
B3S10	0.375	BN	08	0.004	0.015	130	64	0.0034	0.0042	0.0005	1.125
	0.375	BNL	08	0.004	0.002	130	64	0.0034	0.0042	0.0005	1.125
	0.500	SN	05	0.006	0.007	170	120	0.0114	0.0142	0.0017	1.250
	0.500	SN	02	0.005	0.007	170	120	0.0159	0.0187	0.0017	1.750
	0.500	SNA	02	0.005	0.003	170	120	0.0193	0.0221	0.0017	1.750
B3S15	0.500	SN	01	0.006	0.007	170	88	0.0320	0.0348	0.0017	2.500
	0.500	BN	02	0.003	0.015	800	61	0.0253	0.0282	0.0017	1.563
	0.500	BNL	02	0.003	0.002	800	61	0.0253	0.0282	0.0017	1.563
	0.625	SN	02	0.005	0.007	200	120	0.0480	0.0550	0.0042	1.875
	0.625	BN	05	0.003	0.015	800	61	0.0397	0.0467	0.0042	1.250
	0.625	BNL	05	0.003	0.002	800	61	0.0397	0.0467	0.0042	1.250
B3S20	0.750	SN	01	0.005	0.007	300	120	0.1185	0.1329	0.0087	2.813
	0.750	SN	02	0.005	0.007	300	120	0.1159	0.1224	0.0087	3.438
	0.750	SN	01	0.005	0.007	300	120	0.1565	0.1630	0.0087	5.000
	0.750	BN	02	0.004	0.015	2700	120	0.1159	0.1224	0.0087	3.125
	0.750	BNL	02	0.004	0.002	2700	120	0.1159	0.1224	0.0087	3.125
	0.750	BN	05	0.003	0.015	950	120	0.1045	0.1110	0.0087	2.188
0.750	BNL	05	0.003	0.002	950	120	0.1045	0.1110	0.0087	2.188	

METRIC LEAD SCREWS											
ACTUATOR SERIES	SCREW DIA. (mm)	SCREW TYPE	LEAD (mm/turn)	LEAD ACCURACY (mm/300)	BACKLASH (mm)	MAXIMUM THRUST* (N)	MAXIMUM STROKE (mm)	INERTIA (kg-m ² x 10 ⁻⁶)			BREAKAWAY TORQUE (N-m)
								BASE ACTUATOR		PER/mm OF STROKE	
								In Line	Rev. Parallel		
M3S10	10	BN	2.5	0.13	0.38	800	3048	1.14	1.43	0.176	0.13
	10	BNL	2.5	0.13	0.05	800	3048	1.14	1.43	0.176	0.13
	12	SN	12	0.13	0.18	800	3048	3.03	4.50	0.410	0.20
	12	SN	25	0.13	0.18	800	1626	8.54	9.21	0.410	0.28
M3S15	15	SN	12	0.13	0.18	900	3048	11.35	12.96	0.966	0.27
	16	BN	5	0.13	0.38	7300	3048	11.93	14.04	1.258	0.16
	16	BNL	5	0.13	0.05	7300	3048	11.93	14.04	1.258	0.16
M3S20	19	SN	25	0.13	0.18	1400	3048	34.05	38.26	2.517	0.32
	19	SN	12	0.13	0.18	1400	3048	44.96	35.04	2.517	0.39
	19	SN	25	0.13	0.18	1400	3048	33.14	46.86	2.517	0.57
	20	BN	5	0.13	0.38	11700	3048	36.97	39.28	3.102	0.25
20	BNL	5	0.13	0.05	11700	3048	36.97	39.28	3.102	0.25	

SCREW CODE	DESCRIPTION
SN	Solid Nut
SNA	Anti-backlash Solid Nut
BN	Ball Nut
BNL	Low-Backlash Ball Nut



Contact the factory for higher accuracy and lower backlash options.

* For Acme screws, maximum thrust is the maximum continuous dynamic thrust subject to Thrust x Velocity limitation.

For ball screws, maximum thrust reflects 90% reliability for 1 million linear inches of travel.

Axi-dyne® B3S/M3S Screw Drives

OVERALL SERIES SPECIFICATIONS

GENERAL ACTUATOR SPECIFICATIONS

B3S ENGLISH ACTUATORS						
ACTUATOR SERIES	CARRIER WEIGHT (lb)	BASE WEIGHT (lb)	WEIGHT PER/IN OF STROKE (lb)	STRAIGHTNESS & FLATNESS (in) ¹ (Supported)	TEMPERATURE RANGE ² (F°)	IP RATING ³
B3S10	0.85	2.15	0.300	0.00067 x L*	40 - 130	44
B3S15	1.56	8.75	0.570	0.00067 x L*	40 - 130	44
B3S20	2.15	14.38	0.880	0.00067 x L*	40 - 130	44

M3S METRIC ACTUATORS						
ACTUATOR SERIES	CARRIER WEIGHT (kg)	BASE WEIGHT (kg)	WEIGHT PER/mm OF STROKE (g)	STRAIGHTNESS & FLATNESS (mm) ¹ (Supported)	TEMP. RANGE ² (C°)	IP RATING ³
M3S10	0.40	1.00	5.40	0.00067 x L*	4 - 54	44
M3S15	0.70	3.96	10.18	0.00067 x L*	4 - 54	44
M3S20	0.97	6.52	15.73	0.00067 x L*	4 - 54	44



RODLESS

- B3S/M3S Series**
- General actuator specifications
 - Friction Force
 - Support recommendations



¹ The listed values relating to straightness/flatness are intended for reference purposes only, and not as an engineering standard of absolute tolerance for a given actuator. Appropriate installation is the single most important factor in reducing such deviation, so good engineering practices such as measurement, mapping, etc. must be employed in applications with stringent straightness/flatness requirements.

² Heat generated by the motor and drive should be taken into consideration as well as linear velocity and work cycle time. For applications that require operation outside of the recommended temperature range, contact the factory.

³ Protected against ingress of solid particles greater than .039 in (1mm) and splashing water.

* "L" is maximum distance between supports— See the support recommendation diagram below.

LARGE FRAME MOTORS AND SMALLER SIZE ACTUATORS: Cantilevered motors need to be supported, if subjected to continuous rapid reversing duty and/or under dynamic conditions.

SUPPORT RECOMMENDATIONS

FRICITION FORCE

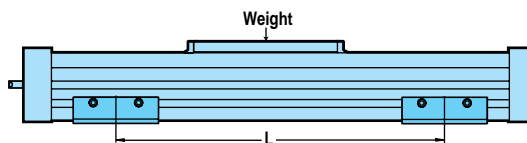
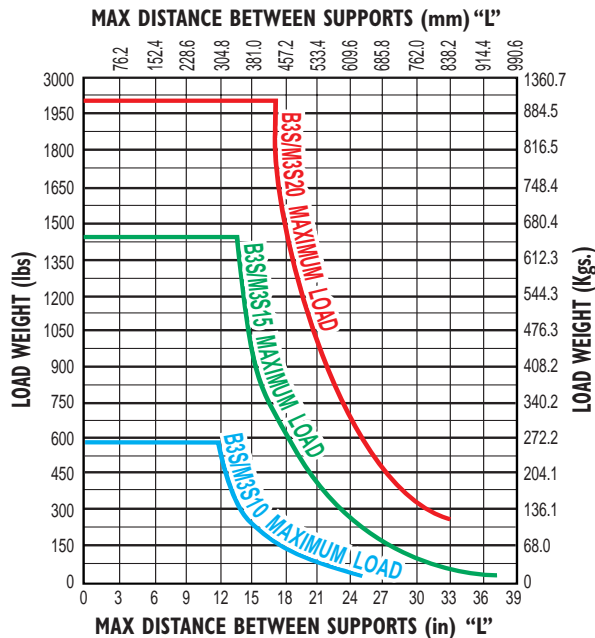
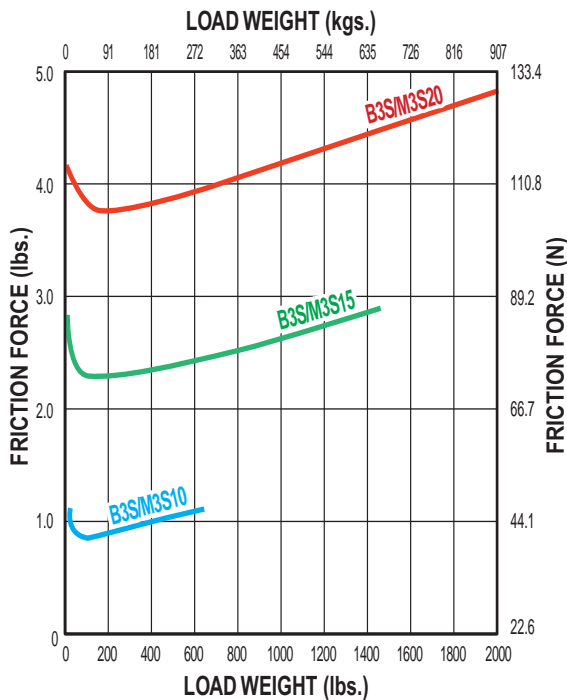

Axi-dyne® B3S/M3S Screw Drives

OVERALL SERIES SPECIFICATIONS

DYNAMIC BENDING MOMENTS AND LOADS



RODLESS

B3S/M3S Series

- Bending moments and loads

STANDARD CARRIER		MAXIMUM BENDING MOMENTS AND LOADS			ENGLISH			METRIC		
		B3S10	B3S15	B3S20	M3S10	M3S15	M3S20			
	Mx Moment (Roll)	(lb-in : N-m)	250	859	1662	28.2	97.1	187.8		
	My Moment (Pitch)	(lb-in : N-m)	269	1033	1472	30.4	116.7	166.3		
	Mz Moment (Yaw)	(lb-in : N-m)	156	596	850	17.9	67.3	96.0		
	Fy Load (Radial)	(lb : N)	341	840	1159	1517	3738	5158		
	Fz Load (Lateral)	(lb : N)	591	1454	2008	2630	6470	8936		
AUXILIARY CARRIER: Increases rigidity, load-carrying capacity and moments			B3S10	B3S15	B3S20	M3S10	M3S15	M3S20		
	Mx Moment (Roll)	*(lb-in : N-m)	500	1718	3324	56.5	194.1	375.6		
	My Moment (Pitch)	*(lb-in : N-m)	2825	11,734	16,265	319.2	1325.8	1837.8		
	Mz Moment (Yaw)	*(lb-in : N-m)	1630	6779	9388	184.2	765.9	1060.8		
	Fy Load (Radial)	(lb : N)	682	1680	2318	3035	7476	10315		
	Fz Load (Lateral)	(lb : N)	1182	2908	4016	5260	1294	17871		
	Minimum Dimension 'D'	(in : mm)	4.88	8.07	8.10	124.0	205.0	205.7		
DUAL 180° CARRIER: Allows 90° rotation of load, adds load bearing surface			B3S10	B3S15	B3S20	M3S10	M3S15	M3S20		
	Mx Moment (Roll)	(lb-in : N-m)	657	2468	4527	74.2	278.9	511.2		
	My Moment (Pitch)	(lb-in : N-m)	312	1192	1700	35.3	134.7	192.1		
	Mz Moment (Yaw)	(lb-in : N-m)	538	2066	2944	60.8	233.4	332.6		
	Fy Load (Radial)	(lb : N)	1182	2908	4016	5260	1294	17871		
	Fz Load (Lateral)	(lb : N)	682	1680	2318	3035	7476	10315		
AUXILIARY DUAL 180° CARRIER: Substantially increases moment and loads			B3S10	B3S15	B3S20	M3S10	M3S15	M3S20		
	Mx Moment (Roll)	*(lb-in : N-m)	1314	4936	9054	147	553	1014		
	My Moment (Pitch)	*(lb-in : N-m)	3328	13558	18776	373	1518	2103		
	Mz Moment (Yaw)	*(lb-in : N-m)	5768	23468	32530	646	2628	3643		
	Fy Load (Radial)	(lb : N)	2364	5816	8032	1072	2638	3643		
	Fz Load (Lateral)	(lb : N)	1364	3360	4636	619	1524	2103		
	Minimum Dimension 'D'	(in : mm)	4.88	8.07	8.10	124.0	205.0	205.7		



The Dual 180° carrier requires its own proprietary tube supports and foot mounts. See dimensional information. Breakaway torque will also increase when using the Auxiliary carrier or the Dual 180° carrier options. When ordering, determine your working stroke and enter this value into the configuration string. Overall actuator length will automatically be calculated.

Deflection Considerations: In applications where substantial Mx or My moments come into play, deflection of the cylinder tube, carrier and supports must be considered. The deflection factors shown in the Load Deflection charts on the following page, are based on cylinder mounted with tube supports at minimum recommended spacing. If more rigidity is desired, refer to the Auxiliary or Dual Carrier options.

*Loads shown in table are at minimum "D" dimension, for ratings with longer "D" dimension see graph on page C-9 or C-10.

Axi-dyne® B3S/M3S Screw Drives

OVERALL SERIES SPECIFICATIONS

LOAD DEFLECTION

Y-AXIS DEFLECTION

Figures calculated with the following considerations:

- 1.) Tube supports spaced at minimum distances for each bore size
- 2.) Measurement distance from F to center of carrier is 13 inches

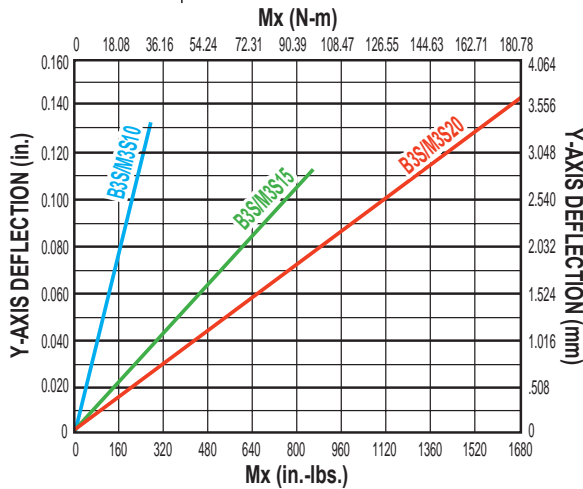
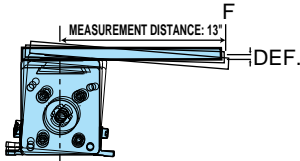

X-AXIS DEFLECTION

Figures calculated with the following considerations:

- 1.) Tube supports spaced at minimum distances for each bore size
- 2.) Measurement distance from F to center of carrier is 8 inches

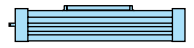
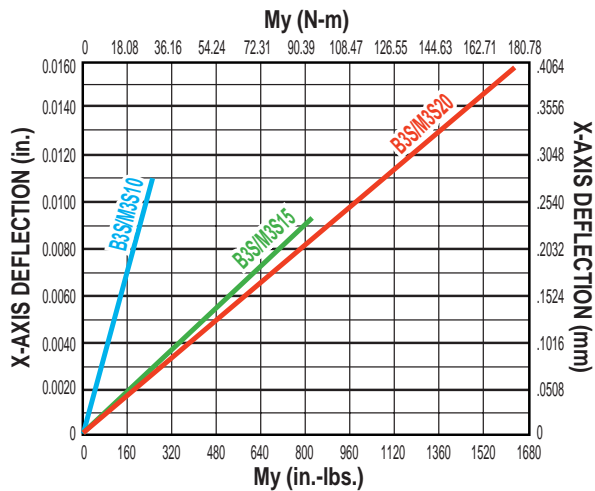
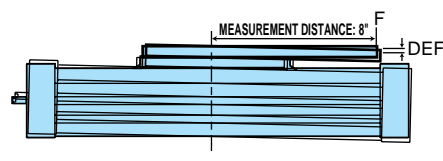

RODLESS

B3S/M3S Series

- Load deflection
- Distance between auxiliary carriers

AUXILIARY CARRIER: BENDING MOMENT AT 'D' DISTANCE

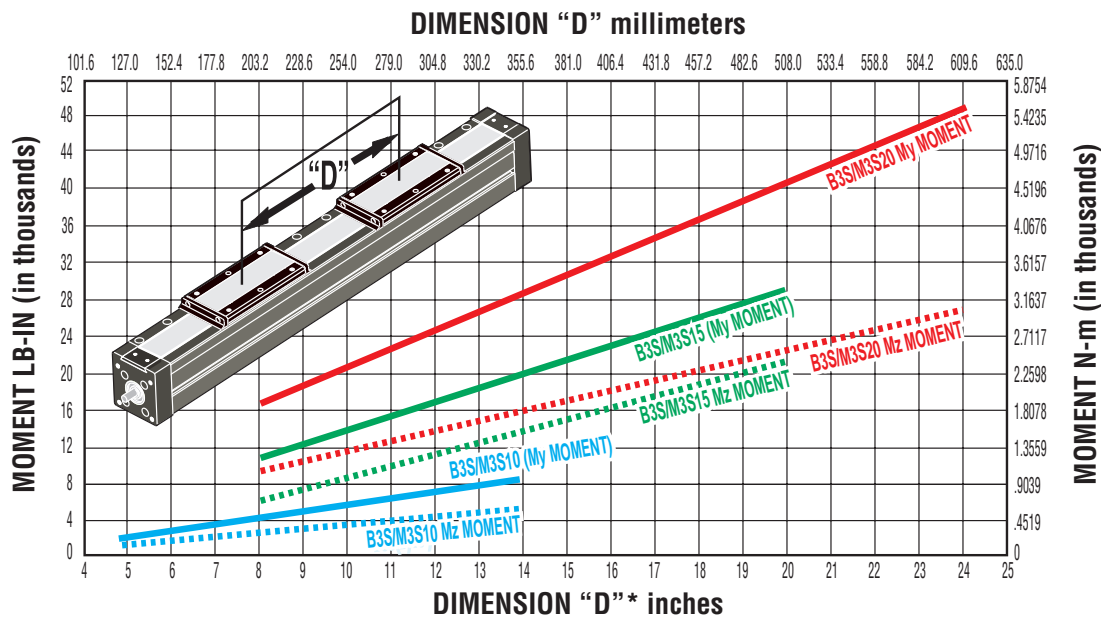

Rates shown on charts were calculated with these assumptions:

- 1.) Coupling between carriers is rigid.
- 2.) Load is equally distributed between carriers.
- 3.) Coupling device applies no misalignment loads to carriers.

* Customer must specify Dimension "D" (Distance between carrier center lines) in configuration string.

Axi-dyne® B3S/M3S Screw Drives

OVERALL SERIES SPECIFICATIONS

AUXILIARY DUAL 180° CARRIER: BENDING MOMENT AT 'D' DISTANCE



RODLESS

B3S/M3S Series

- Distance between auxiliary dual 180° carriers

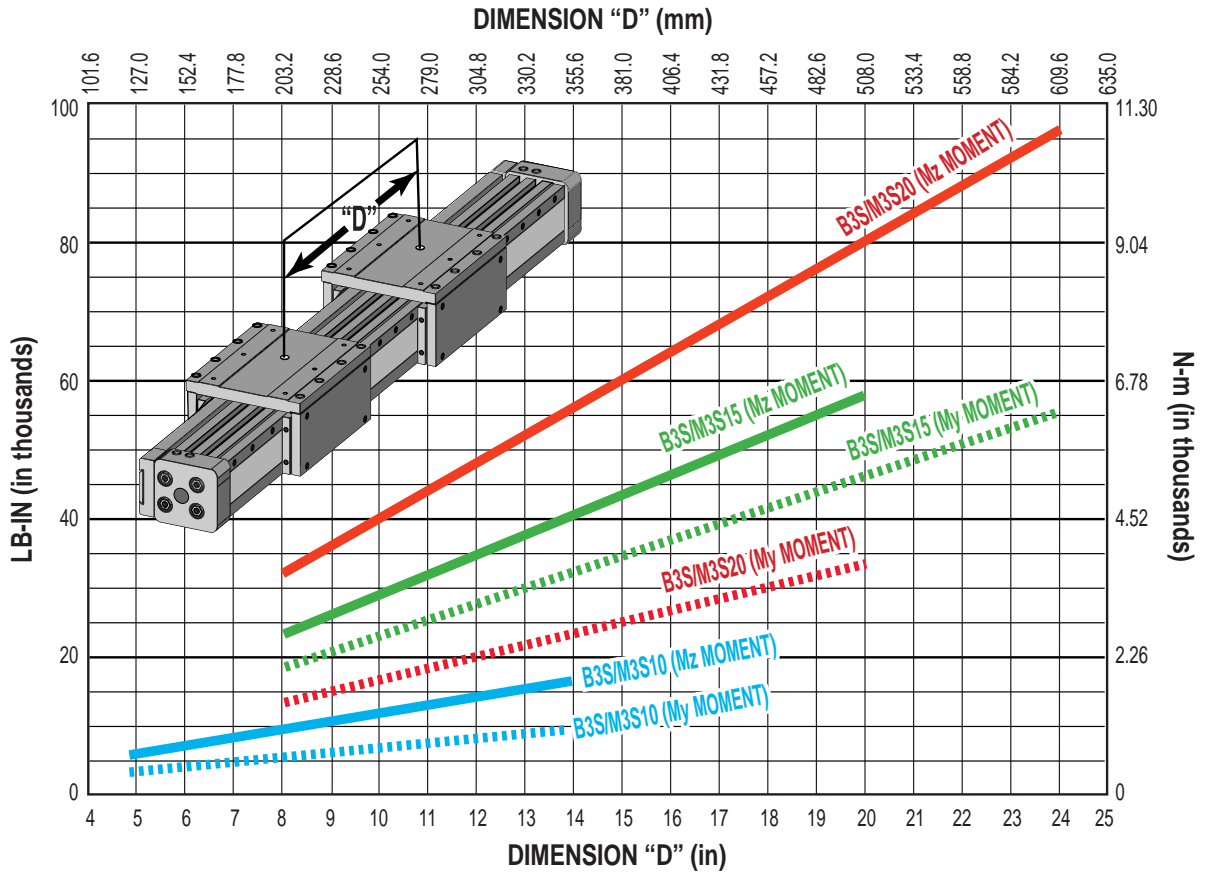

Rates shown on charts were calculated with these assumptions:

- 1.) Coupling between carriers is rigid.
- 2.) Load is equally distributed between carriers.
- 3.) Coupling device applies no misalignment loads to carriers.

* Customer must specify Dimension "D" (Distance between carrier center lines) in configuration string.

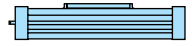

RODLESS

B3S/M3S10 Series

- Acme screw critical speed capacities and PV limits

B3S10/M3S10 ACME SCREW CRITICAL SPEED AND PV LIMITS

CRITICAL SPEED WITH 1/2" ENGLISH ACME SCREW

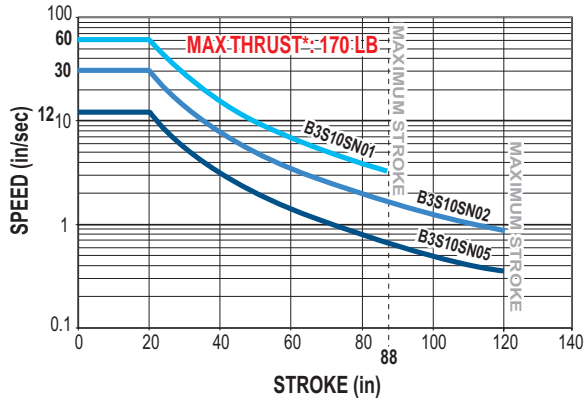

CRITICAL SPEED WITH 12mm METRIC ACME SCREW

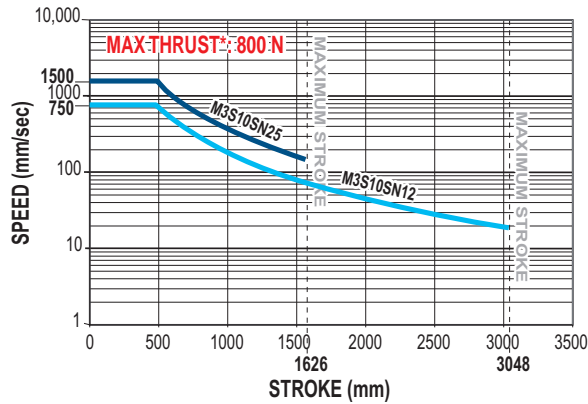

PV LIMITS: 1/2" 1 TPI ENGLISH ACME SCREW

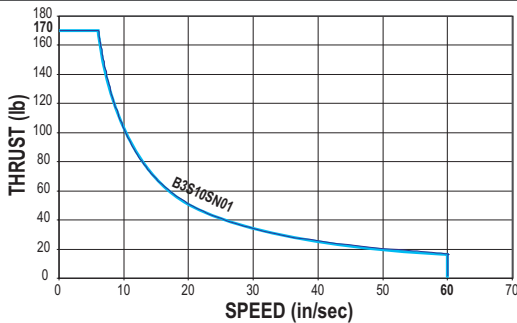

PV LIMITS: 12mm ACME METRIC SCREW w/25mm LEAD

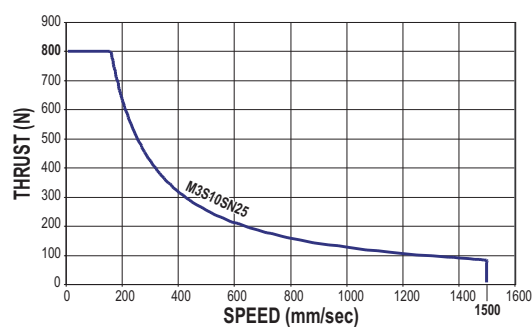

PV LIMITS: 1/2" 2 TPI ENGLISH ACME SCREW

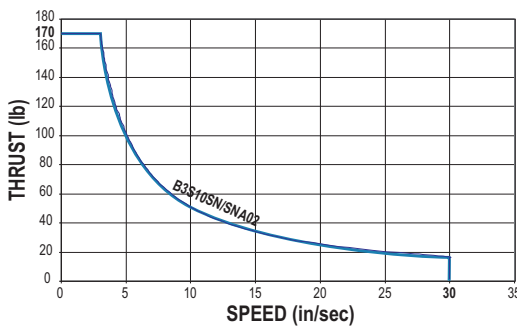

PV LIMITS: 12mm ACME METRIC SCREW w/12mm LEAD

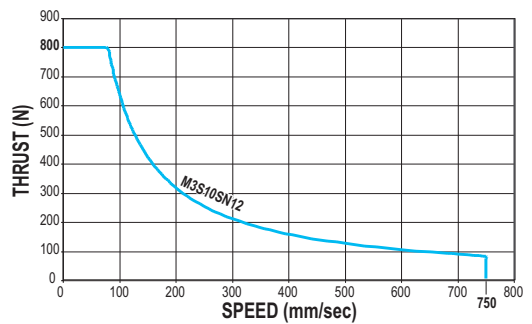

PV LIMITS: 1/2" 5 TPI ENGLISH ACME SCREW

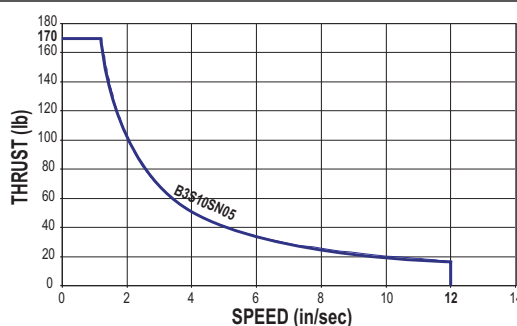

SN = Solid Nut

SNA = Solid Anti-backlash Nut



** Maximum thrust is the maximum continuous dynamic thrust subject to Thrust x Velocity limitation.*

PV LIMITS: Any material which carries a sliding load is limited by heat buildup. The factors that affect heat generation rate in an application are the pressure on the nut in pounds per square inch and the surface velocity in feet per minute. The product of these factors provides a measure of the severity of an application.

$$P = \frac{\text{Thrust}}{\text{Max. Thrust Rating}} \times V = \frac{\text{Speed}}{\text{Max. Speed Rating}} \leq 0.1$$

Axi dyne® B3S/M3S10 Series

BALL SCREW SPECIFICATIONS

B3S/M3S10 BALL SCREW SPECIFICATIONS

CRITICAL SPEED WITH 3/8" ENGLISH BALL SCREW

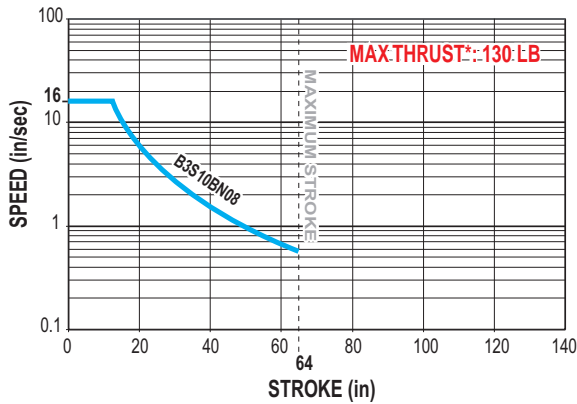

CRITICAL SPEED WITH 10mm METRIC BALL SCREW

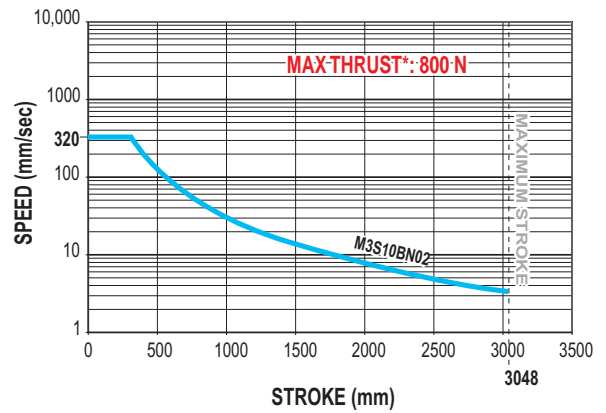

LIFE CALCULATION: 3/8" 8TPI ENGLISH BALL SCREW

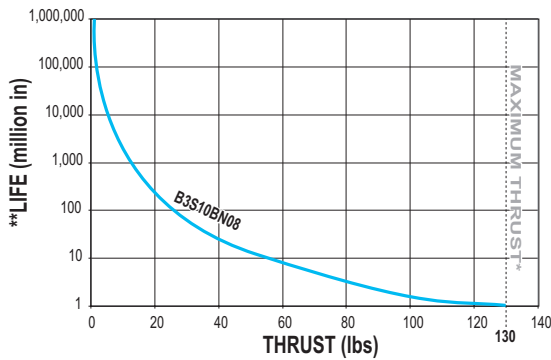

LIFE CALCULATION: 10mm METRIC BALL SCREW w/2.5mm LEAD

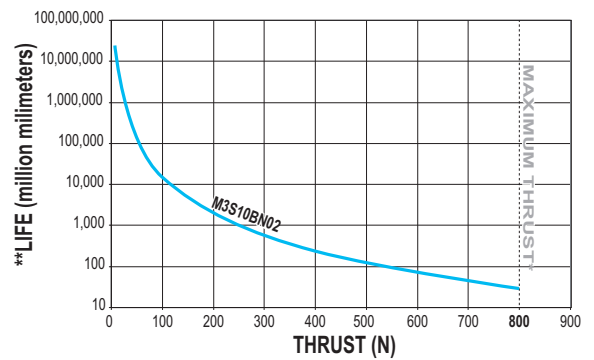

BN = Ball Nut



** Maximum thrust reflects 90% reliability for 1 million linear inches of travel.*

***Life indicates theoretical maximum life of screw only, under ideal conditions and does not indicate expected life of actuator.*

Axi-dyne® B3S/M3S10 Series

DIMENSIONS

B3S10/M3S10 ACTUATOR AND OPTIONS

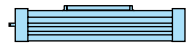
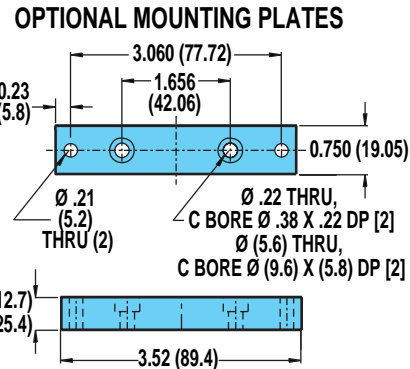
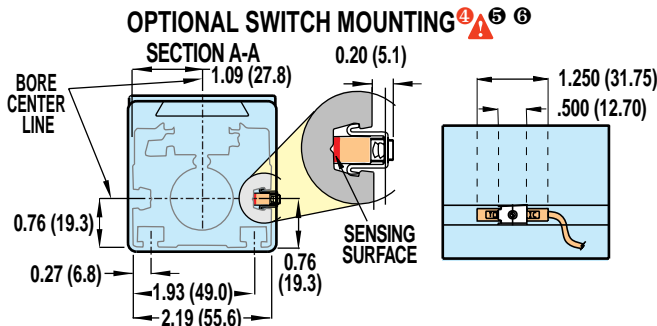
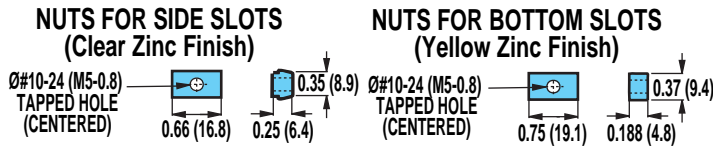
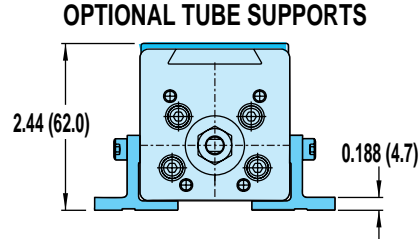
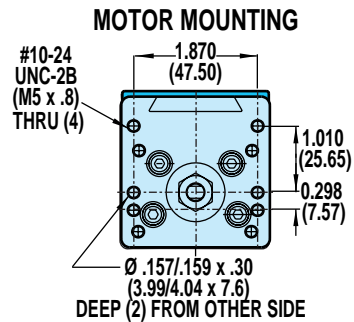
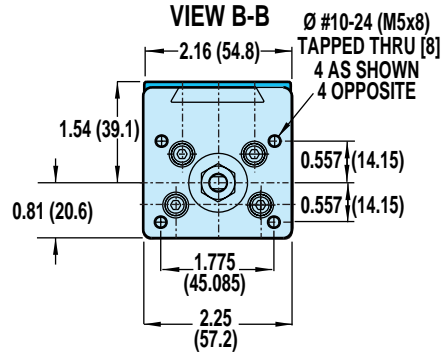
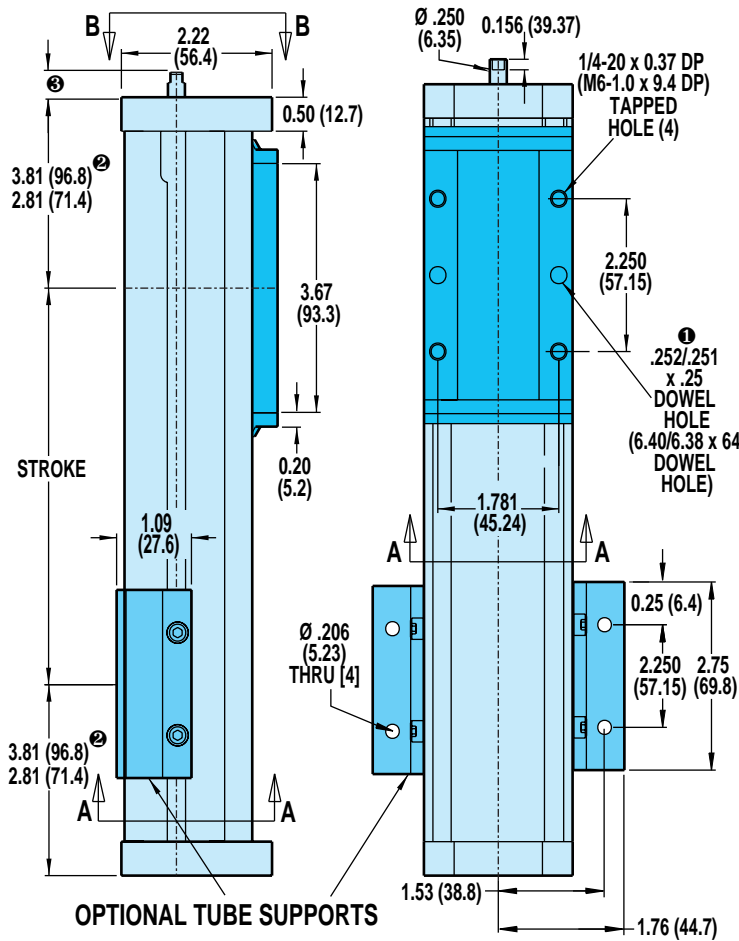

RODLESS

B3S/M3S10 Series
 • Actuator and options dimensions

① DOWEL PINS \oplus .003 (08mm) M

② FOR SNAO2 STYLE ONLY

③ SHAFT LENGTH

In-line mounting	0.55 (13.8)
Extended shaft for RP & 23-frame motor	1.99 (50.5)
Extended shaft for RP & 34-frame motor	2.20 (55.9)
Extended shaft for purchases prior to 6/24/02	2.20 (55.9)

⚠ **CAUTION: DO NOT OVERTIGHTEN SWITCH HARDWARE WHEN INSTALLING**

④ NOTE: The scored face of the switch indicates the sensing surface and must face toward the magnet

⑤ NOTE: Some actuators require switch mounting on a specific side of the actuator. Call Tol-O-Matic 1-800-328-2174 for details

⑦ WHEN USED WITH 23-FRAME BRUSHED DC AND STEPPER MOTORS

⑧ WHEN USED WITH 34-FRAME MOTORS OR ALL MRV MOTORS

Unless otherwise noted, all dimensions shown are in inches (Dimensions in parenthesis are in millimeters)

Axi dyne® B3S/M3S10 Series

DIMENSIONS

B3SD/M3SD10 DUAL 180° OPTION



RODLESS

B3S/M3S10 Series
• Dual 180° carrier dimensions

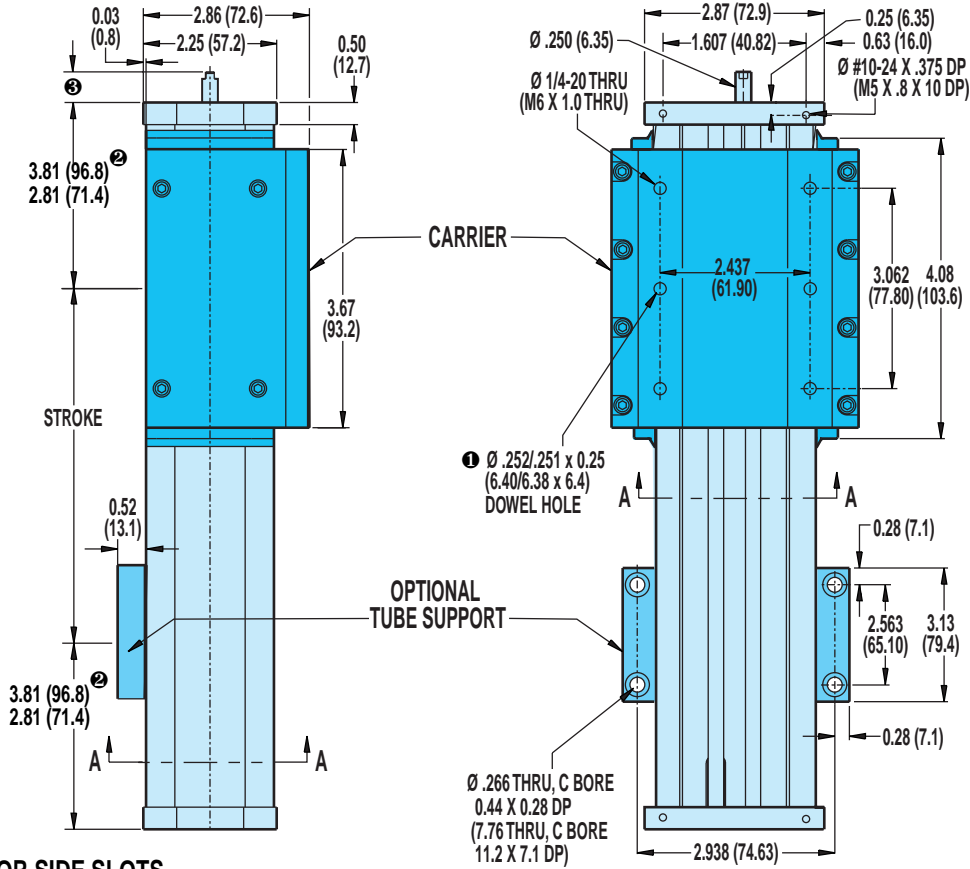

NUTS FOR SIDE SLOTS (Clear Zinc Finish)

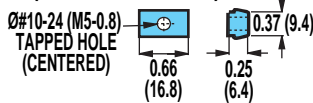

OPTIONAL SWITCH MOUNTING ⚠️ ⚡️

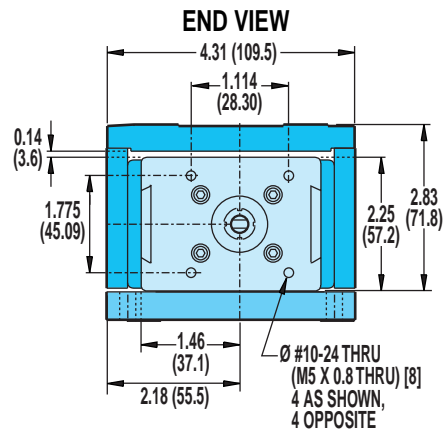
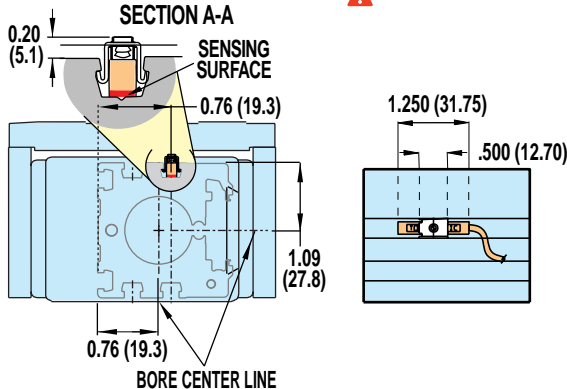

① DOWEL PINS Ⓢ .003 (08mm) Ⓜ

② FOR SNAO2 STYLE ONLY

③ SHAFT LENGTH

In-line mounting	0.55 (13.8)
Extended shaft for RP & 23-frame motor	1.99 (50.5)
Extended shaft for RP & 34-frame motor	2.20 (55.9)
Extended shaft for purchases prior to 6/24/02	2.20 (55.9)

⚠️ CAUTION: DO NOT OVERTIGHTEN SWITCH HARDWARE WHEN INSTALLING

⚡️ NOTE: The scored face of the switch indicates the sensing surface and must face toward the magnet

Ⓢ NOTE: Some actuators require switch mounting on a specific side of the actuator. Call Tol-O-Matic 1-800-328-2174 for details

Axi dyne® B3S/M3S10 Series

DIMENSIONS

B3S/M3S10: IN-LINE MOUNT FOR 23-FRAME STEPPER (MRS) OR BRUSHED DC (MRB) MOTORS (Not for use with gearhead reduction)

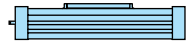
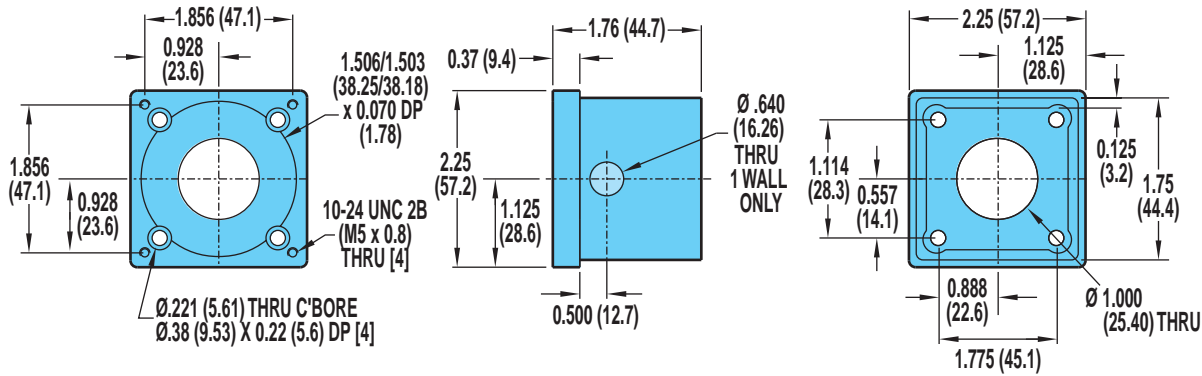

RODLESS

B3S/M3S10 Series

- In-line mounting dimensions

B3S/M3S10: IN-LINE MOUNT FOR 34-FRAME STEPPER (MRS) OR BRUSHED DC (MRB) MOTORS (Not for use with gearhead reduction)

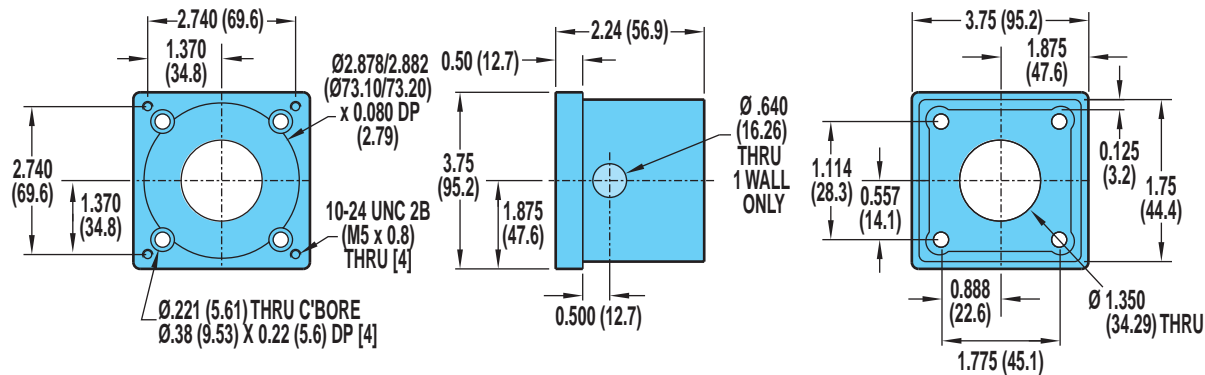

B3S/M3S10: IN-LINE MOUNT FOR BRUSHLESS SERVO (MRV) MOTORS OR GEARHEADS

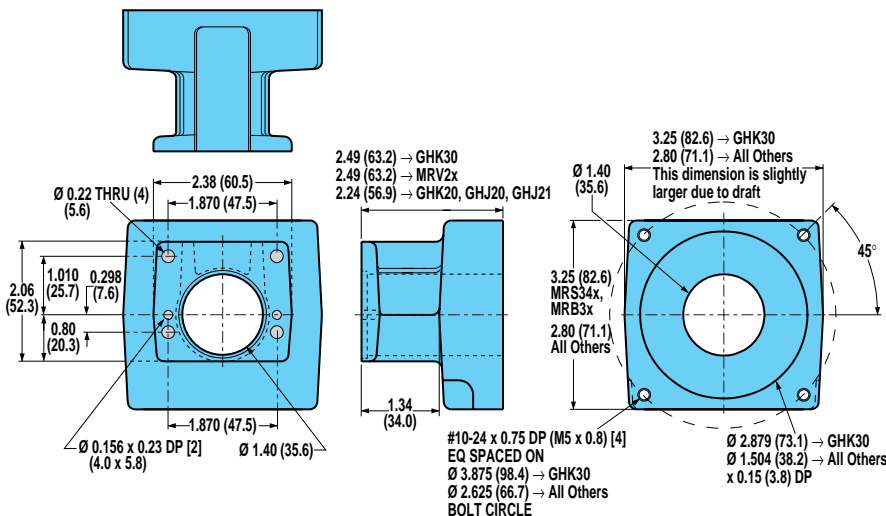

! For a complete part listing of screw-drive motor and gearhead mounting kits referencing actuator/motor/coupler compatibilities, refer to document 3600-4631 available on the Literature/Part Sheet/Axidyne section of our web site at: www.tolomatic.com.

For gearhead dimensions and specifications, refer to page F-10

Axi dyne® B3S/M3S10 Series

DIMENSIONS

B3S/M3S10: REVERSE PARALLEL MOUNTING



RODLESS

B3S/M3S10 Series

- Reverse parallel mounting

SIDE MOUNT (Right Shown)

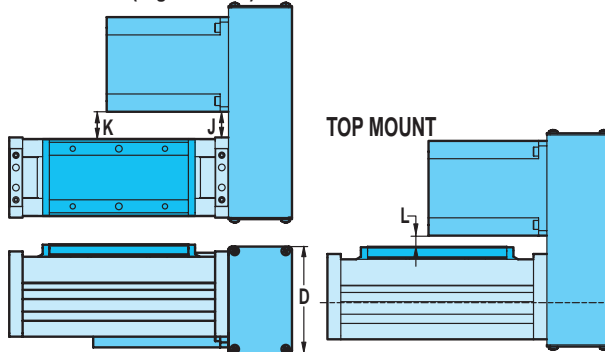

BOTTOM MOUNT

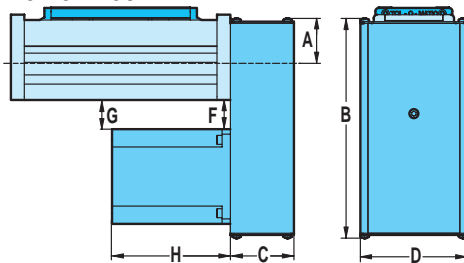

SPECIFICATIONS

MOTOR	WEIGHT OF REDUCTION DRIVE				REDUCTION INERTIA AT MOTOR SHAFT			
	1:1		2:1		1:1		2:1	
	lbs	kg	lbs	kg	lb-in ²	kg-m ² x 10 ⁻⁴	lb-in ²	kg-m ² x 10 ⁻⁴
BRUSHLESS MRV21, 22, 23, 24	2.06	.9344	2.06	.9344	0.0875	25.59	0.1125	32.91
STEPPER MRS231, 232	1.92	.8709	1.92	.8709	0.0219	6.41	0.0463	13.54
STEPPER MRS341, 342 342, 343	2.34	1.0614	2.34	1.0614	0.0250	7.31	0.0500	14.61
BRUSHED MRB21	1.92	.8709	1.92	.8709	0.0219	6.41	0.0463	13.54
BRUSHED MRB31, 32	2.46	1.1158	2.46	1.1158	0.0875	25.59	0.1125	32.91

REDUCTION EFFICIENCY: 0.95

DIMENSIONS

	MOTOR	A		B		C		D		F		G		H		J		K		L	
		in.	mm	in.	mm	in.	mm	in.	mm	in.	mm	in.	mm	in.	mm	in.	mm	in.	mm	in.	mm
BRUSHLESS	MRV21	1.44	36.6	6.96	176.7	2.13	54.0	3.25	82.6	1.80	45.6	1.84	46.8	4.75	120.7	1.48	37.6	1.51	38.4	1.06	26.9
	MRV22	1.44	36.6	6.96	176.7	2.13	54.0	3.25	82.6	1.80	45.6	1.84	46.8	5.75	146.1	1.48	37.6	1.51	38.4	1.06	26.9
	MRV23	1.44	36.6	6.96	176.7	2.13	54.0	3.25	82.6	1.80	45.6	1.84	46.8	6.75	171.5	1.48	37.6	1.51	38.4	1.06	26.9
	MRV24	1.44	36.6	6.96	176.7	2.13	54.0	3.25	82.6	1.80	45.6	1.84	46.8	7.75	196.9	1.48	37.6	1.51	38.4	1.06	26.9
STEPPER	MRS231	1.44	36.6	6.96	176.7	2.13	54.0	3.25	82.6	1.80	45.6	1.84	46.8	2.06	52.3	1.48	37.6	1.51	38.4	1.06	26.9
	MRS232	1.44	36.6	6.96	176.7	2.13	54.0	3.25	82.6	1.80	45.6	1.84	46.8	3.10	78.7	1.48	37.6	1.51	38.4	1.06	26.9
	MRS341	1.96	49.7	7.47	189.8	2.38	60.3	4.00	101.6	1.23	31.2	1.28	32.4	2.58	65.5	0.84	21.2	0.87	22.0	0.50	12.6
	MRS342	1.96	49.7	7.47	189.8	2.38	60.3	4.00	101.6	1.23	31.2	1.28	32.4	3.76	95.5	0.84	21.2	0.87	22.0	0.50	12.6
STEPPER	MRS343	1.96	49.7	7.47	189.8	2.38	60.3	4.00	101.6	1.23	31.2	1.28	32.4	5.06	128.5	0.84	21.2	0.87	22.0	0.50	12.6
BRUSHED	MRB21	1.44	36.6	6.96	176.8	2.13	54.0	3.25	82.6	1.80	45.7	1.84	46.7	6.33	160.8	1.48	37.6	1.51	38.4	1.06	26.9
	MRB31	1.96	49.8	6.96	176.8	2.38	60.3	4.00	101.6	1.29	32.8	1.34	33.9	5.07	128.8	0.92	23.2	0.95	24.0	0.56	14.1
	MRB32	1.96	49.8	7.47	189.7	2.38	60.3	4.00	101.6	1.29	32.8	1.34	33.9	7.72	196.1	0.92	23.2	0.95	24.0	0.56	14.1

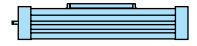
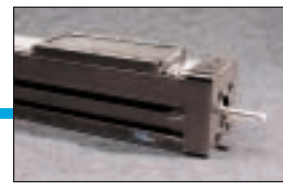

RODLESS

B3S/M3S15 Series
• English acme screw
critical speed capacities
and PV limits

B3S15 ENGLISH ACME SCREW SPECIFICATIONS

CRITICAL SPEED WITH 5/8" ENGLISH ACME SCREW

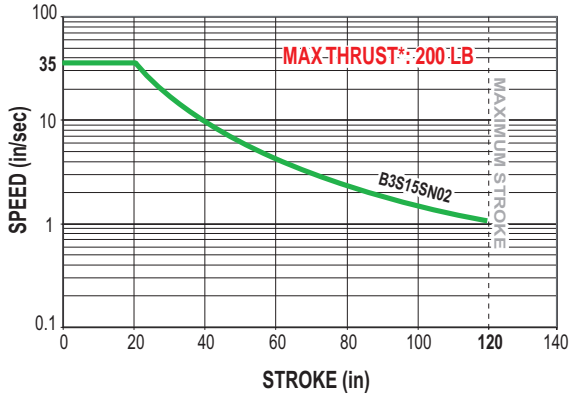

CRITICAL SPEED WITH 3/4" ENGLISH ACME SCREW

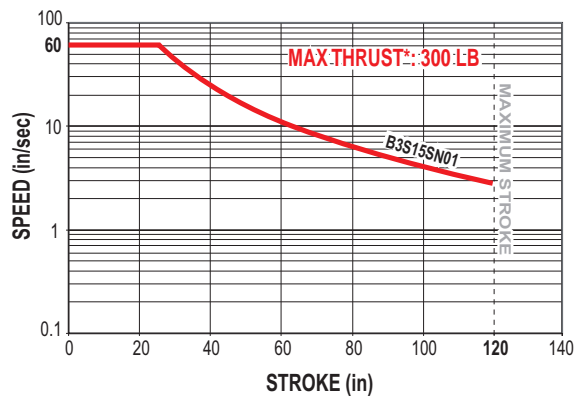

PV LIMITS: 5/8" 2TPI ENGLISH ACME SCREW

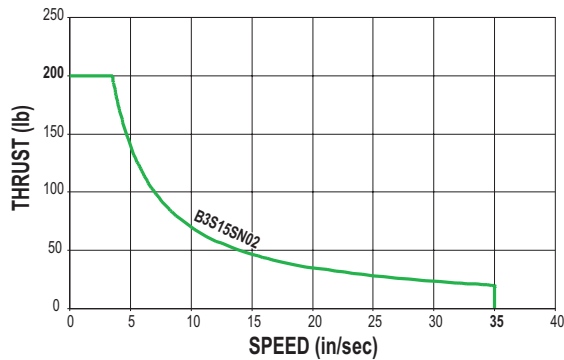

PV LIMITS: 3/4" 1TPI ENGLISH ACME SCREW

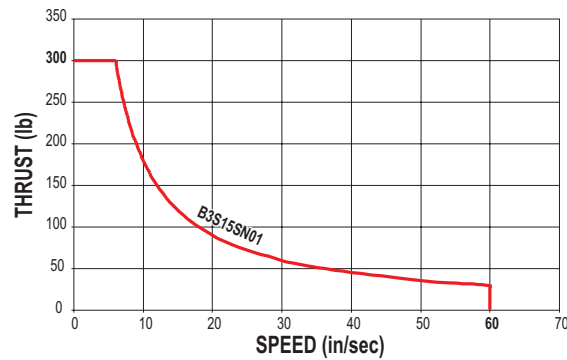

SN = Solid Nut

SNA = Solid Anti-backlash Nut



**Maximum thrust is the maximum continuous dynamic thrust subject to Thrust x Velocity limitation.*

PV LIMITS: Any material which carries a sliding load is limited by heat buildup. The factors that affect heat generation rate in an application are the pressure on the nut in pounds per square inch and the surface velocity in feet per minute. The product of these factors provides a measure of the severity of an application.

$$P = \frac{\text{Thrust}}{\text{Max. Thrust Rating}} \times V = \frac{\text{Speed}}{\text{Max. Speed Rating}} \leq 0.1$$

Axi-dyne® B3S/M3S15 Series

BALL SCREW SPECIFICATIONS

B3S/M3S15 BALL SCREW SPECIFICATIONS

CRITICAL SPEED WITH 1/2" ENGLISH BALL SCREW

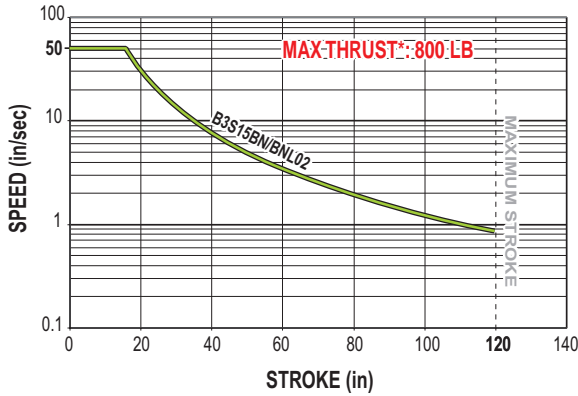

CRITICAL SPEED WITH 16mm METRIC BALL SCREW

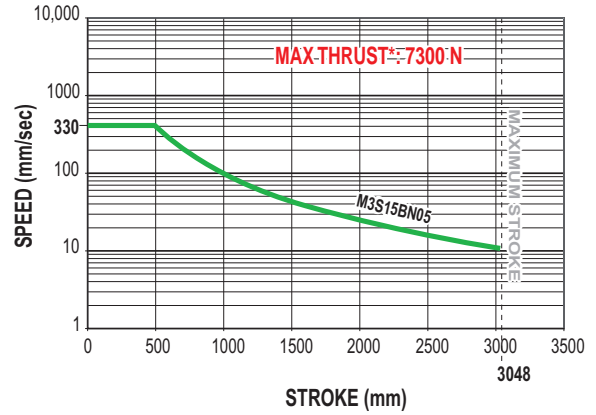

CRITICAL SPEED WITH 5/8" ENGLISH BALL SCREW

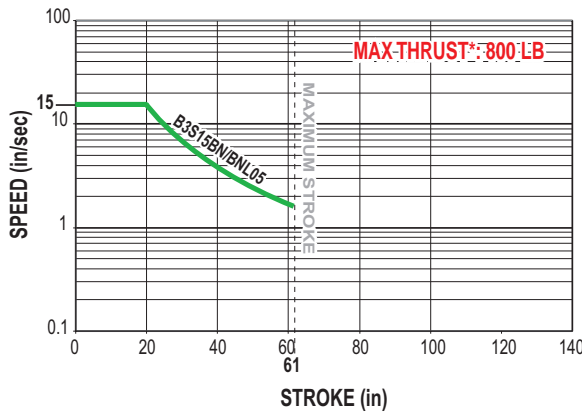

LIFE CALCULATION: 16mm METRIC BALL SCREW w/5mm LEAD

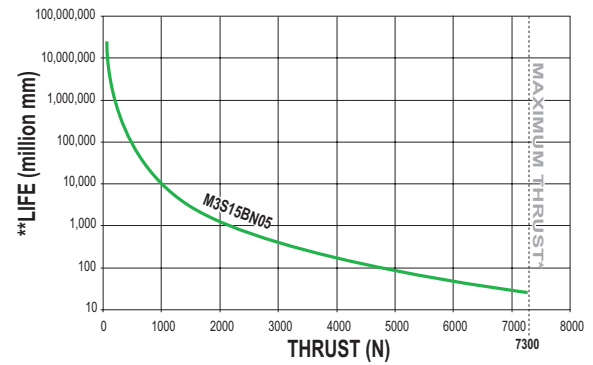

LIFE CALCULATION: 1/2" w/2TPI & 5/8" w/5TPI ENGLISH BALL SCREW

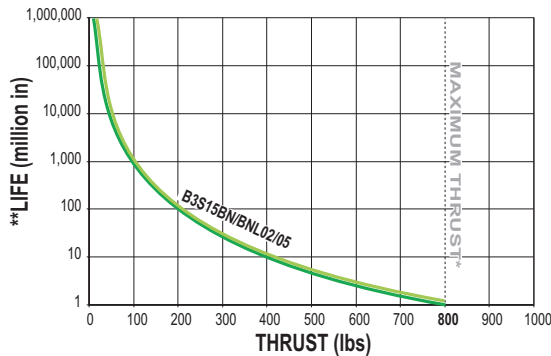

BN = Ball Nut
BNL = Ball Nut with Low-Backlash

! *Maximum thrust reflects 90% reliability for 1 million linear inches of travel.

**Life indicates theoretical maximum life of screw only, under ideal conditions and does not indicate expected life of actuator.

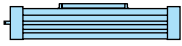

RODLESS

B3S/M3S15 Series

- Ball screw critical speed capacities and life calculations

Axi-dyne® B3S/M3S15 Series

ACME SCREW SPECIFICATIONS

M3S15 METRIC ACME SCREW SPECIFICATIONS

CRITICAL SPEED WITH 15mm METRIC ACME SCREW

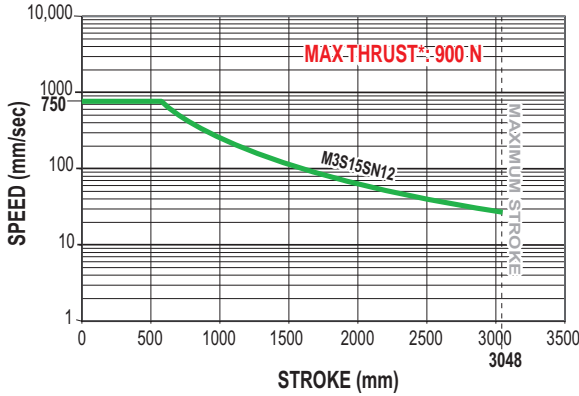

CRITICAL SPEED WITH 19mm METRIC ACME SCREW

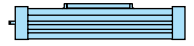
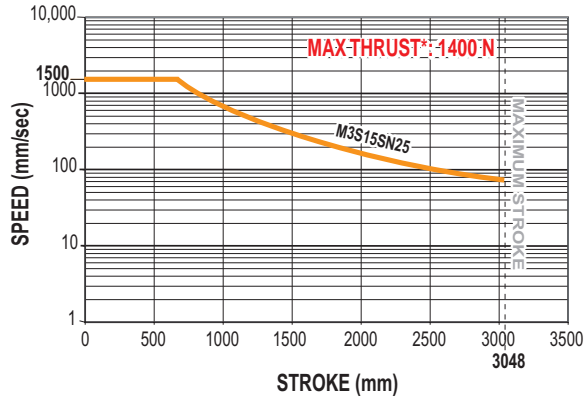

RODLESS

B3S/M3S15 Series
 • Metric acme screw
 critical speed capacities
 and PV limits

PV LIMITS: 15mm METRIC ACME SCREW w/12mm LEAD



PV LIMITS: 19mm METRIC ACME SCREW w/25mm LEAD

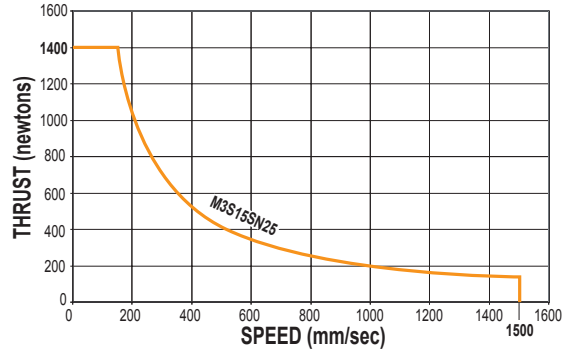

SN = Solid Nut

⚠ *Maximum thrust is the maximum continuous dynamic thrust subject to Thrust x Velocity limitation.

PV LIMITS: Any material which carries a sliding load is limited by heat buildup. The factors that affect heat generation rate in an application are the pressure on the nut in pounds per square inch and the surface velocity in feet per minute. The product of these factors provides a measure of the severity of an application.

$$P = \frac{\text{Thrust}}{\text{Max. Thrust Rating}} \times V = \frac{\text{Speed}}{\text{Max. Speed Rating}} \leq 0.1$$

Axi-dyne® B3S/M3S15 Series

DIMENSIONS

B3S15/M3S15 ACTUATOR AND OPTIONS



RODLESS

B3S/M3S15 Series

• Actuator and option dimensions

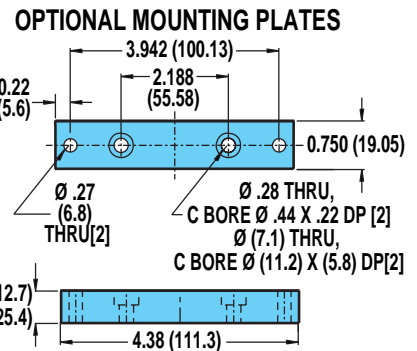
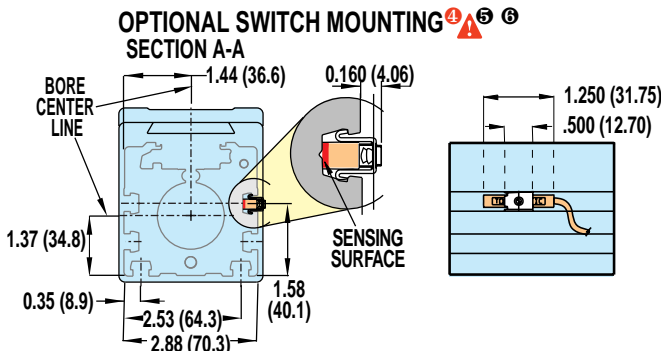
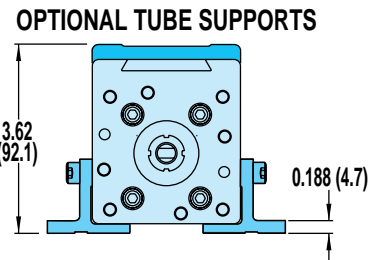
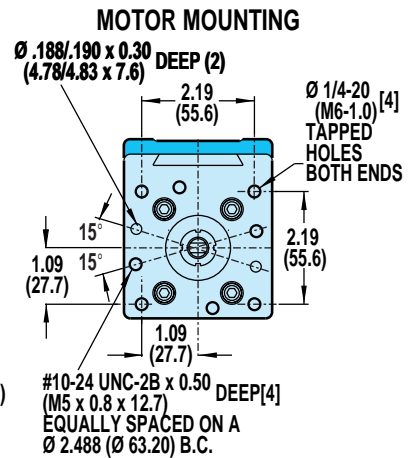
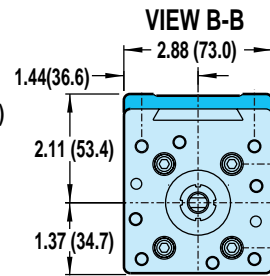
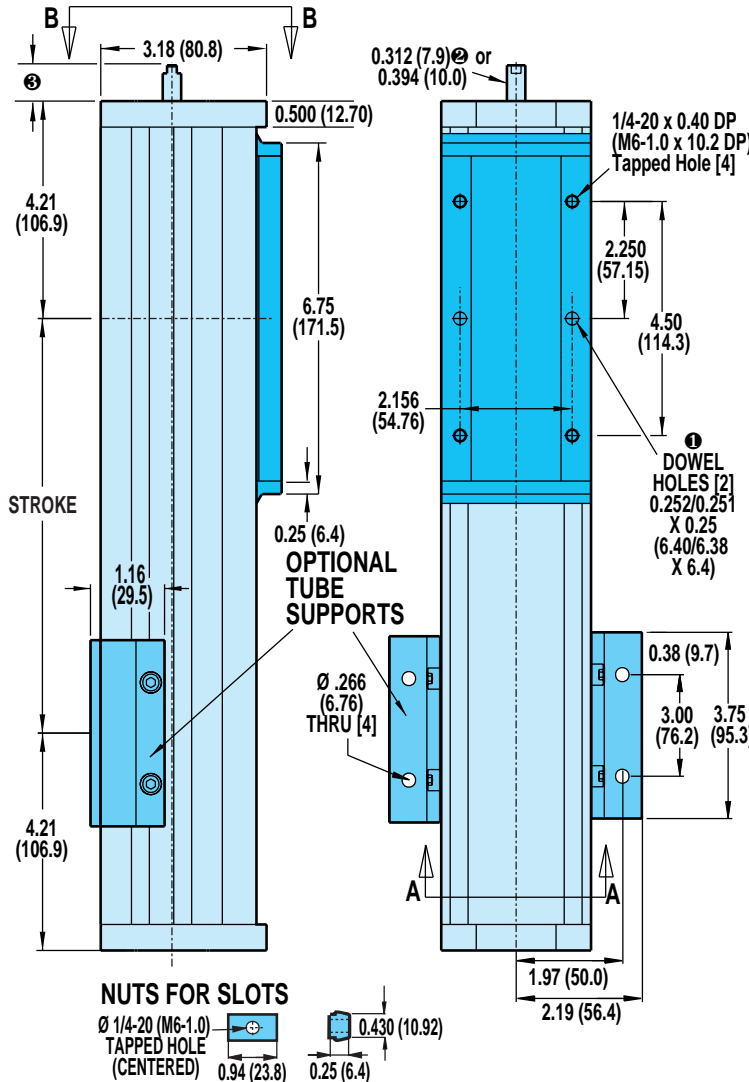

① DOWEL PINS ⌀ .003 (0.08mm) (M)

② FOR B3S15BN02 & B3S15BNL02

③ SHAFT LENGTH

In-line mounting	0.69 (17.5)
Extended shaft for RP & 23-frame motor	1.99 (50.5)
Extended shaft for RP & 34-frame motor	2.20 (55.9)
Extended shaft for RP & 40-frame motor	2.36 (59.9)
Extended shaft for purchases prior to 6/24/02	2.20 (55.9)

⚠ **CAUTION: DO NOT OVERTIGHTEN SWITCH HARDWARE WHEN INSTALLING**

⑤ **NOTE:** The scored face of the switch indicates the sensing surface and must face toward the magnet

⑥ **NOTE:** Some actuators require switch mounting on a specific side of the actuator. Call Tol-O-Matic 1-800-328-2174 for details

⑦ **WHEN USED WITH 23-FRAME BRUSHED DC AND STEPPER MOTORS**

⑧ **WHEN USED WITH 34-FRAME OR 40-FRAME MOTORS**

Unless otherwise noted, all dimensions shown are in inches (Dimensions in parenthesis are in millimeters)

Axi-dyne® B3S/M3S15 Series

DIMENSIONS

B3SD/M3SD15 DUAL 180° OPTION

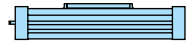
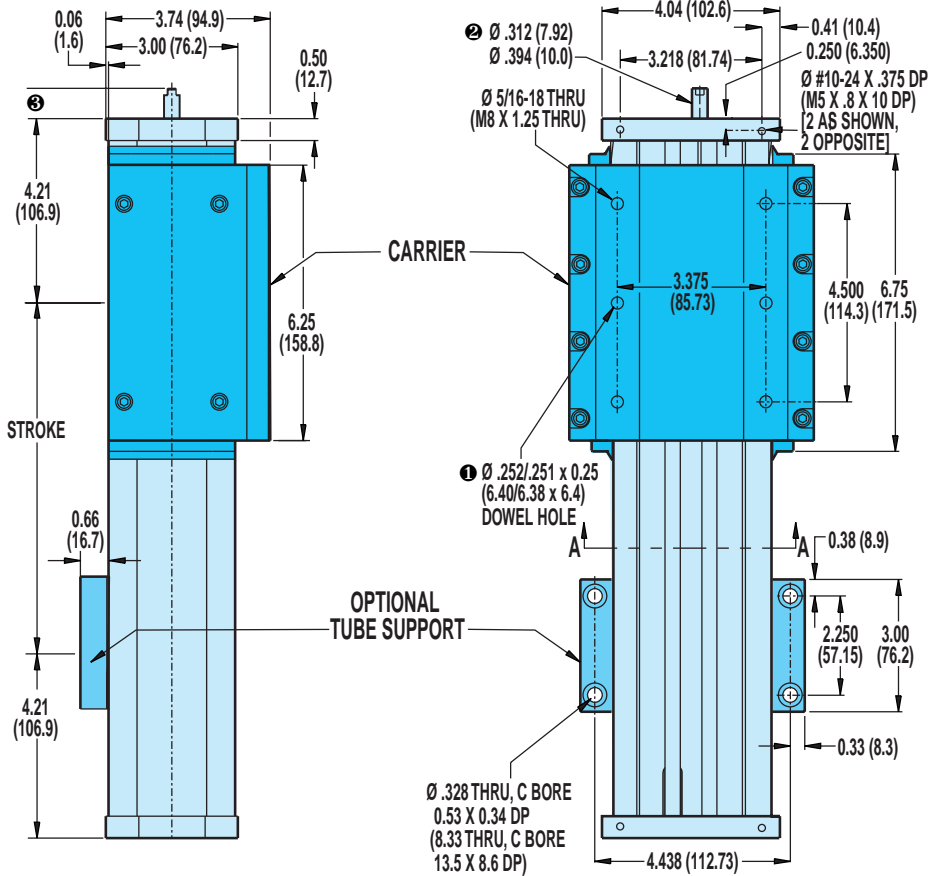

RODLESS

B3S/M3S15 Series
• Dual 180° option dimensions

NUTS FOR SLOTS



OPTIONAL SWITCH MOUNTING

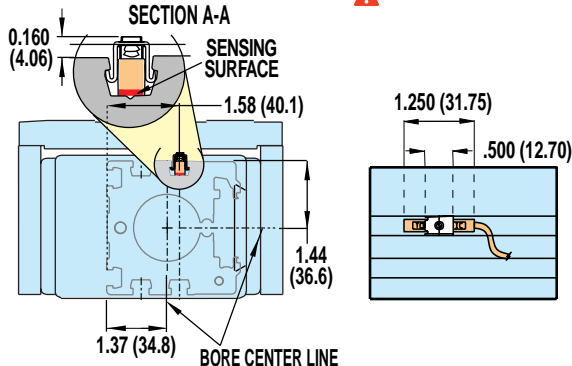

END VIEW

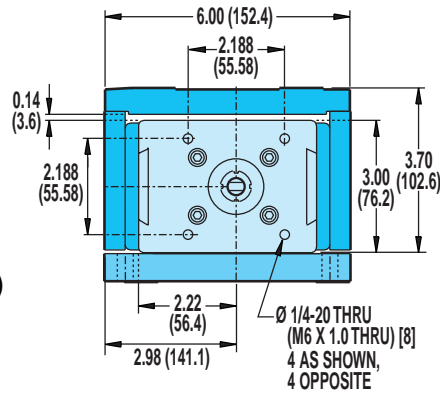

① DOWEL PINS $\varnothing .003$ (08mm) (M)

② FOR B3S15BN02 & B3S15BNL02

③ SHAFT LENGTH

In-line mounting	0.69 (17.5)
Extended shaft for RP & 23-frame motor	1.99 (50.5)
Extended shaft for RP & 34-frame motor	2.20 (55.9)
Extended shaft for RP & 40-frame motor	2.36 (59.9)
Extended shaft for purchases prior to 6/24/02	2.20 (55.9)

⚠ **CAUTION: DO NOT OVERTIGHTEN SWITCH HARDWARE WHEN INSTALLING**

④ NOTE: The scored face of the switch indicates the sensing surface and must face toward the magnet

⑤ NOTE: Some actuators require switch mounting on a specific side of the actuator. Call Tol-O-Matic 1-800-328-2174 for details

Axi-dyne® B3S/M3S15 Series

DIMENSIONS

B3S/M3S15: IN-LINE MOUNT FOR 23-FRAME STEPPER (MRS) OR BRUSHED DC (MRB) MOTORS (Not for use with gearhead reduction)

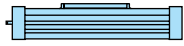

RODLESS

B3S/M3S15 Series
• In-line motor mounting dimensions

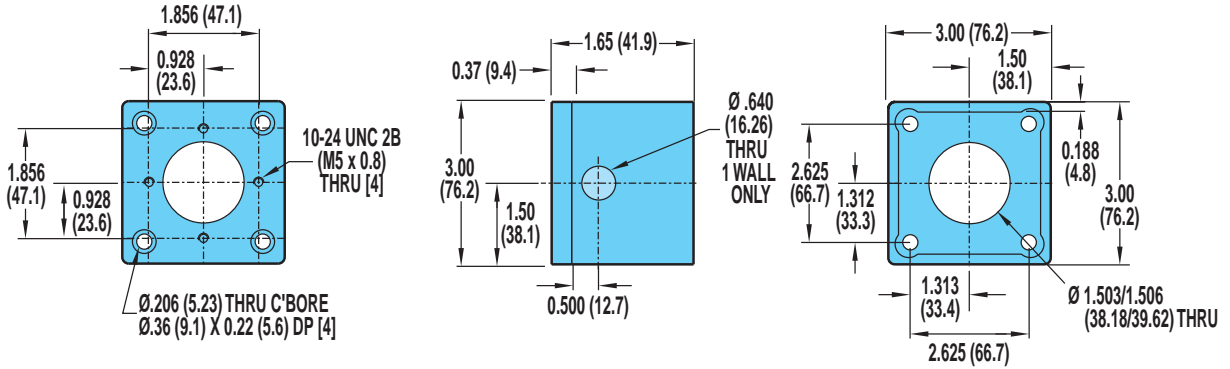

B3S/M3S15: IN-LINE MOUNT FOR 34-FRAME STEPPER (MRS) OR BRUSHED DC (MRB) MOTORS (Not for use with gearhead reduction)

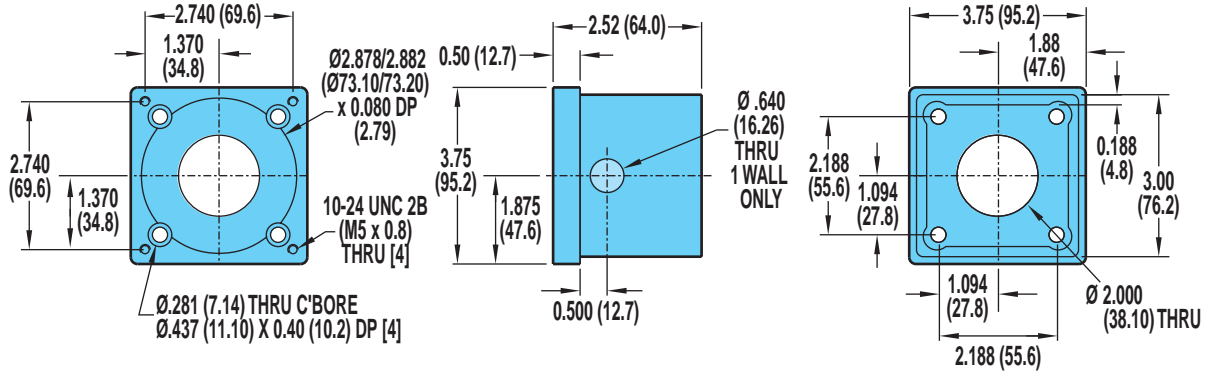

B3S/M3S15: IN-LINE MOUNT FOR BRUSHLESS SERVO (MRV) MOTORS, BRUSHED DC (MRB41, 42) MOTORS OR GEARHEADS

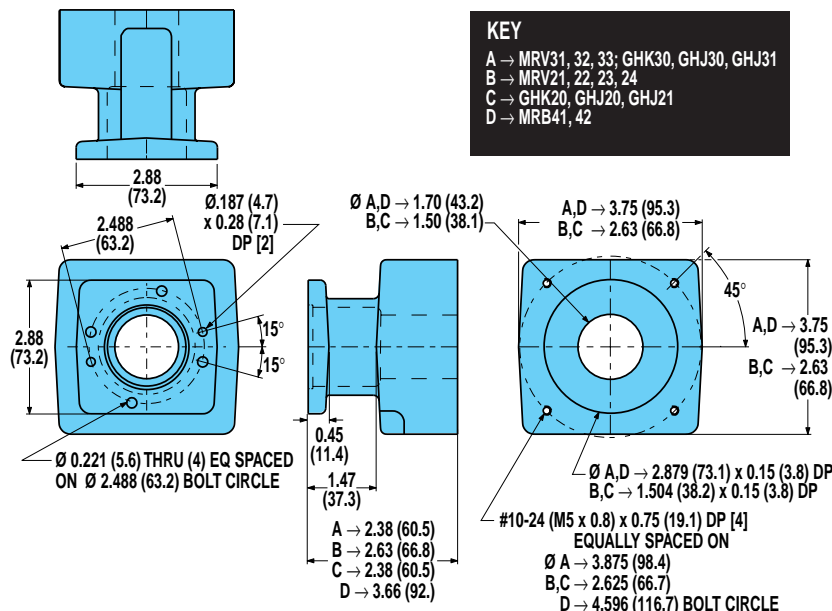

KEY	
A	→ MRV31, 32, 33; GHK30, GHJ30, GHJ31
B	→ MRV21, 22, 23, 24
C	→ GHK20, GHJ20, GHJ21
D	→ MRB41, 42

! For a complete part listing of screw-drive motor and gearhead mounting kits referencing actuator/motor/coupler compatibilities, refer to document 3600-4631 available on the Literature/Part Sheet/Axidyne section of our web site at: www.tolomatic.com.

For gearhead dimensions and specifications, refer to page F-10.

Axi-dyne® B3S/M3S15 Series

DIMENSIONS

B3S/M3S15: REVERSE PARALLEL MOUNTING

SIDE MOUNT (Right Shown)

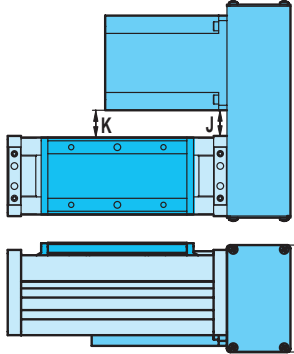

TOP MOUNT

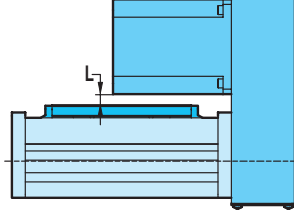

BOTTOM MOUNT

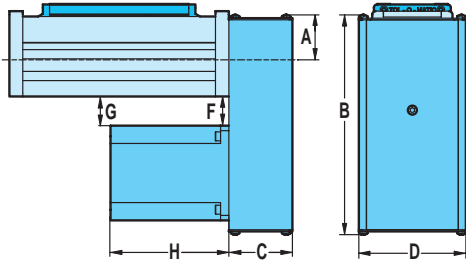

SPECIFICATIONS

MOTOR	WEIGHT OF REDUCTION DRIVE				REDUCTION INERTIA AT MOTOR SHAFT			
	1:1		2:1		1:1		2:1	
	lbs	kg	lbs	kg	lb-in ²	kg-m ² x 10 ⁻⁶	lb-in ²	kg-m ² x 10 ⁻⁶
BRUSHLESS MRV21, 22, 23, 24	2.17	0.98	2.40	1.09	0.0875	25.59	0.1206	35.28
	2.17	0.98	2.40	1.09	0.0875	25.59	0.1206	35.28
STEPPER MRS231, 232	2.03	0.92	2.26	1.03	0.0219	6.41	0.0544	15.91
	2.49	1.13	2.72	1.23	0.0250	7.31	0.0575	16.82
BRUSHED MRB21	2.03	0.92	2.26	1.03	0.0219	6.41	0.0544	15.91
	2.61	1.18	2.84	1.29	0.0875	25.59	0.1206	35.28
	3.73	1.69	3.96	1.80	0.1119	32.73	0.1444	42.24

REDUCTION EFFICIENCY: 0.95

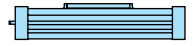

RODLESS

B3S/M3S15 Series
• Reverse parallel mounting

DIMENSIONS

MOTOR	A		B		C		D		F		G		H		J		K		L		
	in.	mm	in.	mm	in.	mm	in.	mm	in.	mm	in.	mm	in.	mm	in.	mm	in.	mm	in.	mm	
BRUSHLESS	MRV21	1.44	36.6	7.46	189.4	2.13	54.0	3.25	82.6	1.74	44.1	1.74	44.1	4.75	120.7	1.61	40.8	1.67	42.3	1.00	25.3
	MRV22	1.44	36.6	7.46	189.4	2.13	54.0	3.25	82.6	1.74	44.1	1.74	44.1	5.75	146.1	1.61	40.8	1.67	42.3	1.00	25.3
	MRV23	1.44	36.6	7.46	189.4	2.13	54.0	3.25	82.6	1.74	44.1	1.74	44.1	6.75	171.5	1.61	40.8	1.67	42.3	1.00	25.3
	MRV24	1.44	36.6	7.46	189.4	2.13	54.0	3.25	82.6	1.74	44.1	1.74	44.1	7.75	196.9	1.61	40.8	1.67	42.3	1.00	25.3
	MRV31	2.12	53.8	8.14	206.6	2.38	60.3	4.00	101.6	1.09	27.7	1.09	27.7	6.11	155.2	0.96	24.4	1.02	25.9	0.35	8.9
	MRV32	2.12	53.8	8.14	206.6	2.38	60.3	4.00	101.6	1.09	27.7	1.09	27.7	7.36	186.9	0.96	24.4	1.02	25.9	0.35	8.9
MRV33	2.12	53.8	8.14	206.6	2.38	60.3	4.00	101.6	1.09	27.7	1.09	27.7	8.61	218.7	0.96	24.4	1.02	25.9	0.35	8.9	
STEPPER	MRS231	1.44	36.6	7.46	189.4	2.13	54.0	3.25	82.6	1.74	44.1	1.74	44.1	2.06	52.3	1.61	40.8	1.67	42.3	1.00	25.3
	MRS232	1.44	36.6	7.46	189.4	2.13	54.0	3.25	82.6	1.74	44.1	1.74	44.1	3.10	78.7	1.61	40.8	1.67	42.3	1.00	25.3
	MRS341	2.12	53.8	8.14	206.6	2.38	60.3	4.00	101.6	1.17	29.7	1.17	29.8	2.58	65.5	1.04	26.4	1.10	27.9	0.43	11.0
	MRS342	2.12	53.8	8.14	206.6	2.38	60.3	4.00	101.6	1.17	29.7	1.17	29.8	3.76	95.5	1.04	26.4	1.10	27.9	0.43	11.0
MRS343	2.12	53.8	8.14	206.6	2.38	60.3	4.00	101.6	1.17	29.7	1.17	29.8	5.06	128.5	1.04	26.4	1.10	27.9	0.43	11.0	
BRUSHED	MRB21	1.44	36.6	7.46	189.4	2.13	54.0	3.25	82.6	1.74	44.1	1.74	44.1	6.33	160.8	1.61	40.8	1.67	42.3	1.00	25.3
	MRB31	2.12	53.8	8.14	206.6	2.38	60.3	4.00	101.6	1.23	31.3	1.23	31.3	5.07	128.8	1.10	27.9	1.16	29.5	0.49	12.5
	MRB32	2.12	53.8	8.14	206.6	2.38	60.3	4.00	101.6	1.23	31.3	1.23	31.3	7.72	196.1	1.10	27.9	1.16	29.5	0.49	12.5
	MRB41	2.34	59.5	8.36	212.3	2.59	65.9	5.00	127.0	0.86	21.9	0.86	21.9	10.63	270.0	0.73	18.5	0.79	20.1	0.12	3.1
	MRB42	2.34	59.5	8.36	212.3	2.59	65.9	5.00	127.0	0.86	21.9	0.86	21.9	11.63	295.4	0.73	18.5	0.79	20.1	0.12	3.1

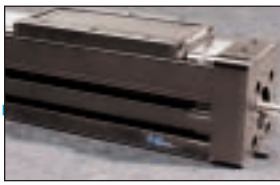

Axi-dyne® B3S/M3S20 Series ACME SCREW SPECIFICATIONS

B3S/M3S20 ACME SCREW SPECIFICATIONS

CRITICAL SPEED WITH 3/4" ENGLISH ACME SCREW

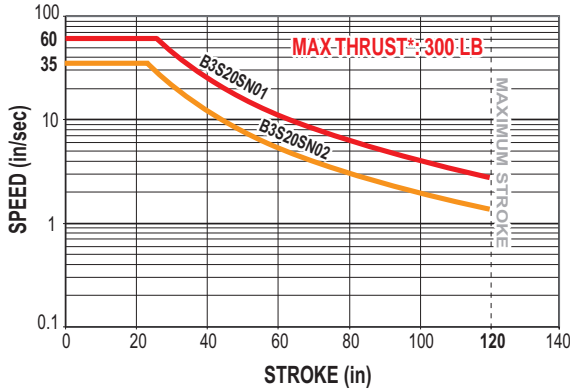

CRITICAL SPEED WITH 19mm METRIC ACME SCREW

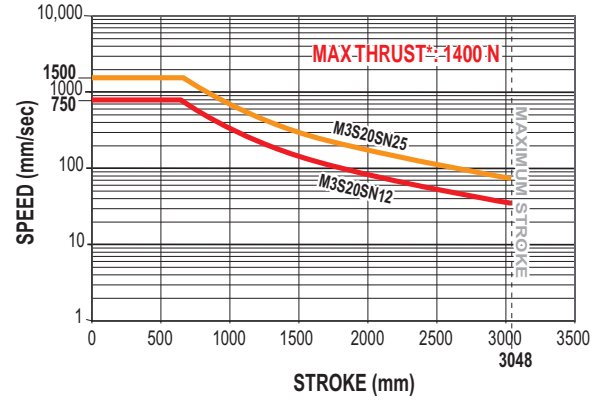

PV LIMITS: 3/4" 1TPI ENGLISH ACME SCREW

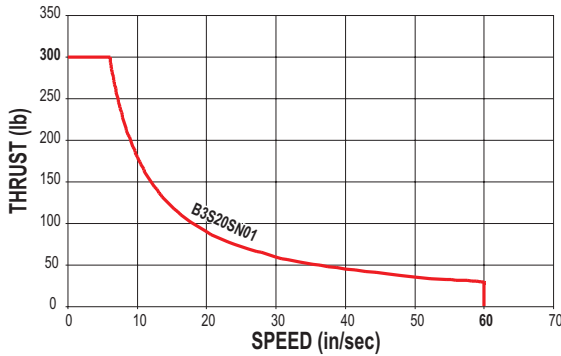

PV LIMITS: 19mm METRIC ACME SCREW w/25mm LEAD

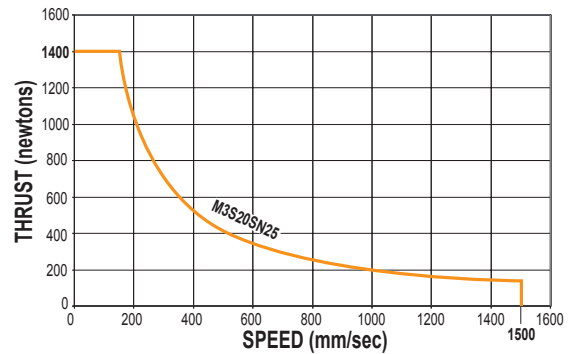

PV LIMITS: 3/4" 2TPI ENGLISH ACME SCREW

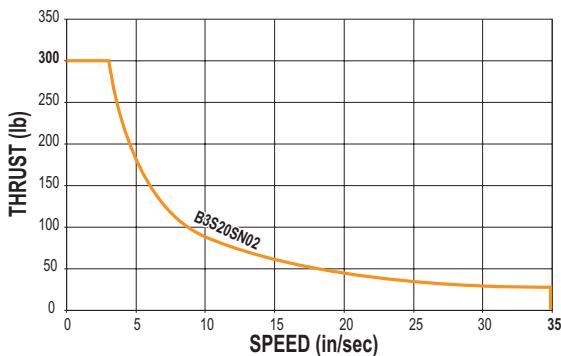

PV LIMITS: 19mm METRIC ACME SCREW w/12mm LEAD

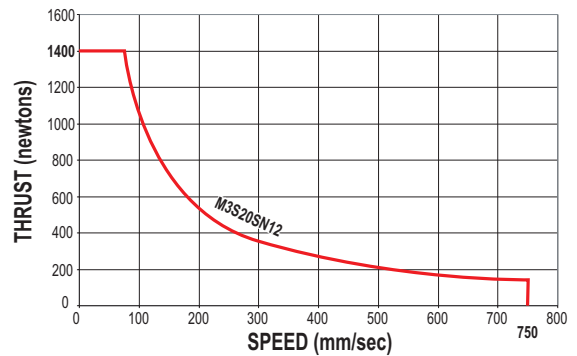

SN = Solid Nut

SNA = Solid Anti-backlash Nut



* Maximum thrust is the maximum continuous dynamic thrust subject to Thrust x Velocity limitation.

PV LIMITS: Any material which carries a sliding load is limited by heat buildup. The factors that affect heat generation rate in an application are the pressure on the nut in pounds per square inch and the surface velocity in feet per minute. The product of these factors provides a measure of the severity of an application.

$$P = \frac{\text{Thrust}}{\text{Max. Thrust Rating}} \times V = \frac{\text{Speed}}{\text{Max. Speed Rating}} \leq 0.1$$

Axi-dyne® B3S/M3S20 Series

BALL SCREW SPECIFICATIONS

B3S20/M3S20 BALL SCREW SPECIFICATIONS

CRITICAL SPEED WITH 3/4" ENGLISH BALL SCREW, 2TPI

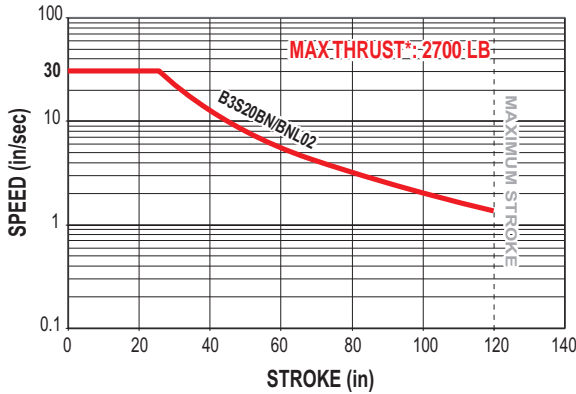

LIFE CALCULATION: 3/4" ENGLISH BALL SCREW, 5TPI

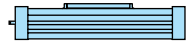
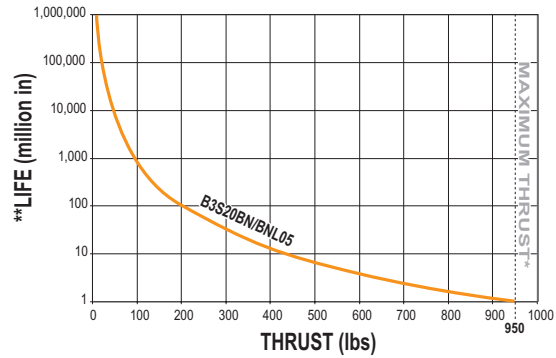

RODLESS

B3S/M3S20 Series

- Ball screw critical speed capacities and life calculations

LIFE CALCULATION: 3/4" ENGLISH BALL SCREW, 2TPI

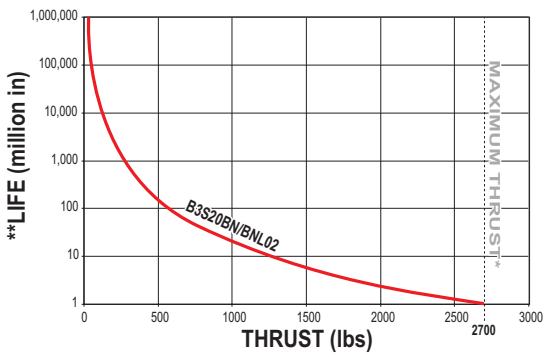

CRITICAL SPEED WITH 20mm METRIC BALL SCREW

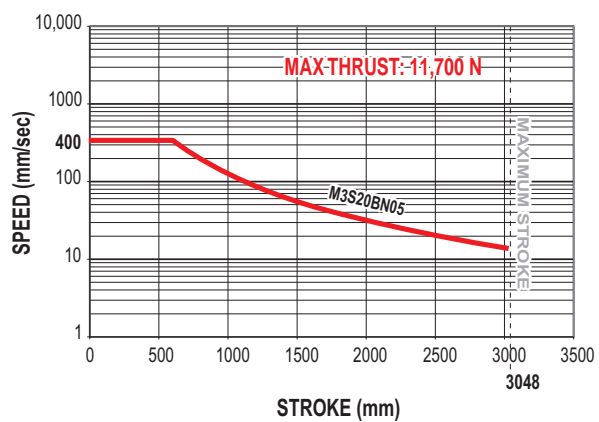

CRITICAL SPEED WITH 3/4" ENGLISH BALL SCREW, 5TPI

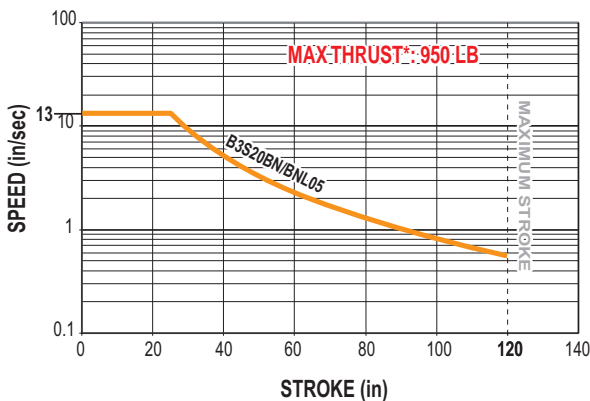

LIFE CALCULATION: 20mm METRIC BALL SCREW w/5mm LEAD

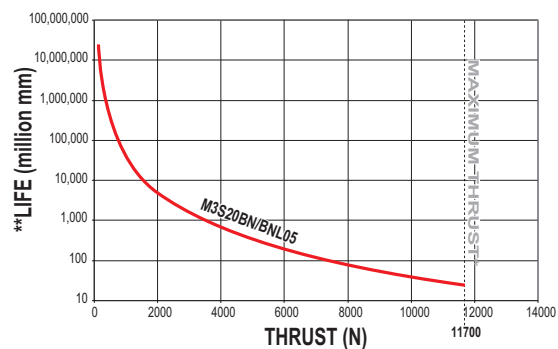

BN = Ball Nut

BNL = Ball Nut with Low-Backlash



* Maximum thrust reflects 90% reliability for 1 million linear inches of travel.

**Life indicates theoretical maximum life of screw only, under ideal conditions and does not indicate expected life of actuator.

Axi-dyne® B3S/M3S20 Series

DIMENSIONS

B3S20 ACTUATOR AND OPTIONS

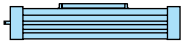

RODLESS

B3S/M3S20 Series

• Actuator and option dimensions

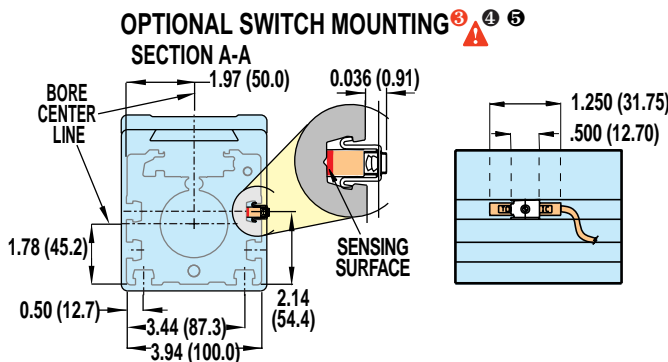
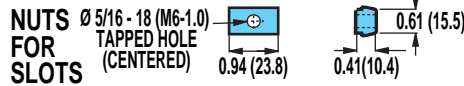
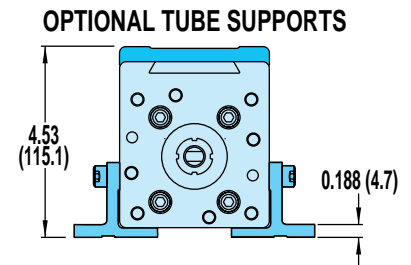
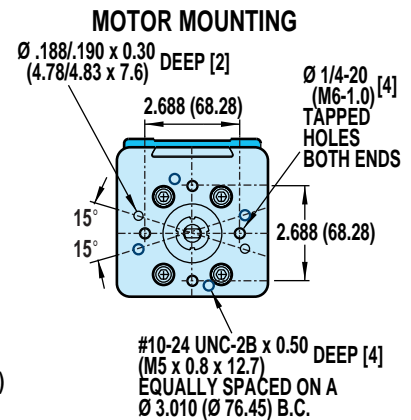
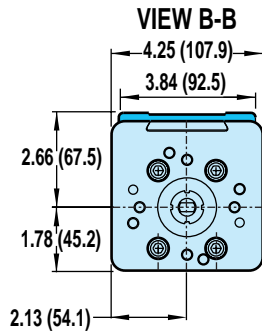
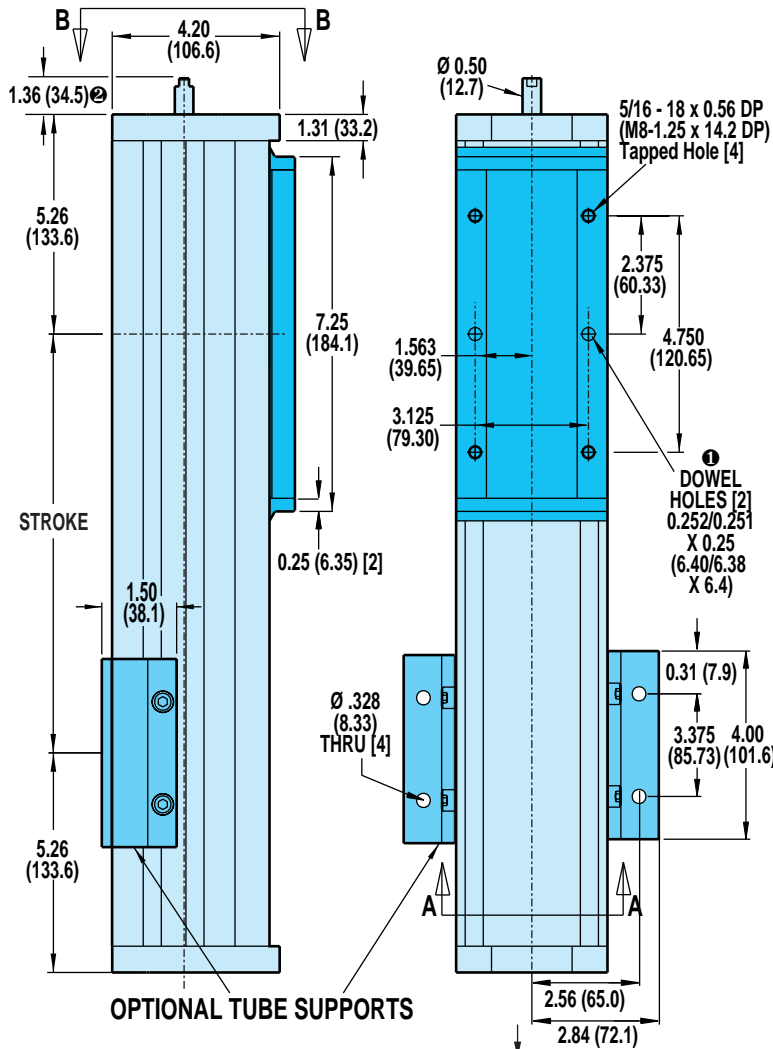

OPTIONAL MOUNTING PLATES

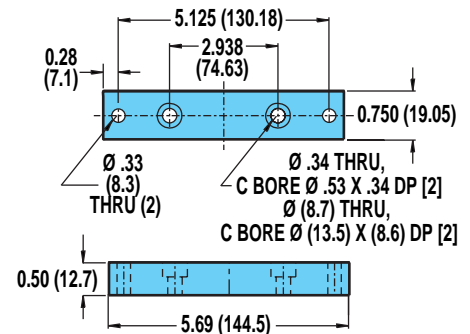

① DOWEL PINS \oplus .003 (08mm) M

② FOR EXTENDED SHAFT 2.11 (53.6)

⚠ **CAUTION: DO NOT OVERTIGHTEN SWITCH HARDWARE WHEN INSTALLING**

④ **NOTE: The scored face of the switch indicates the sensing surface and must face toward the magnet**

⑤ **NOTE: Some actuators require switch mounting on a specific side of the actuator. Call Tol-O-Matic 1-800-328-2174 for details**

Unless otherwise noted, all dimensions shown are in inches (Dimensions in parenthesis are in millimeters)

Axi-dyne® B3S/M3S20 Series

DIMENSIONS

B3SD/M3SD20 DUAL 180° OPTION

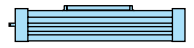
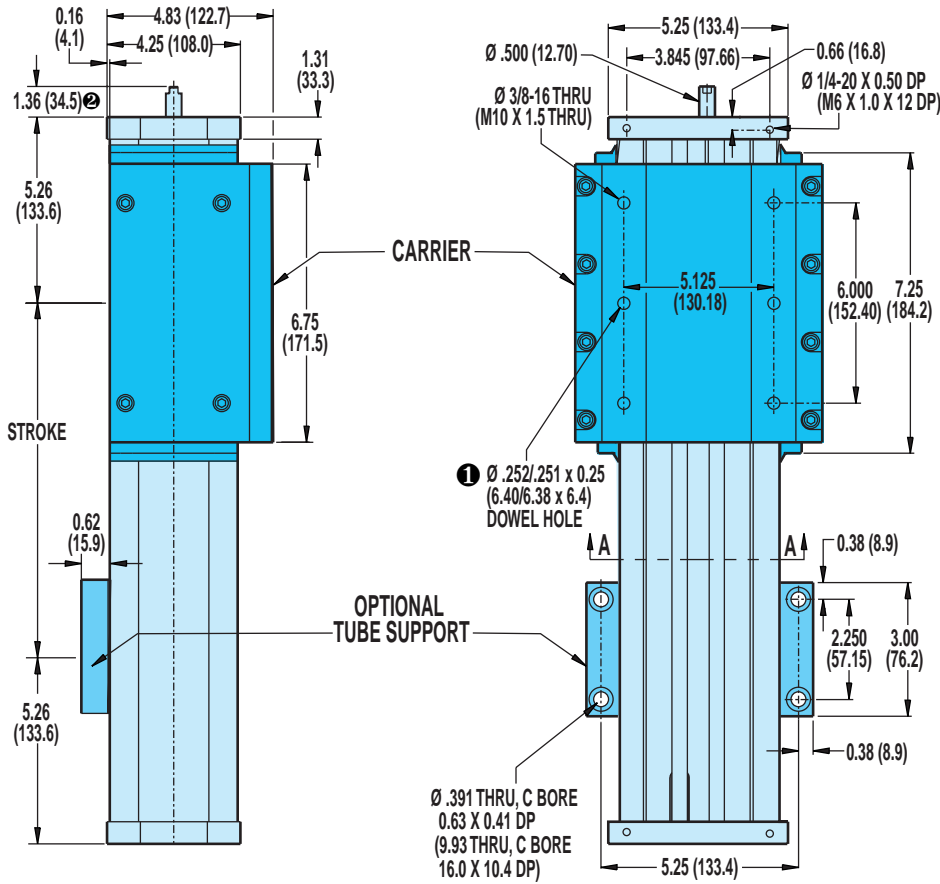

RODLESS

B3S/M3S20 Series
 • Dual 180° option dimensions

NUTS FOR SLOTS

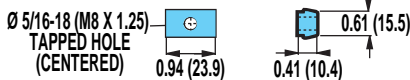

OPTIONAL SWITCH MOUNTING

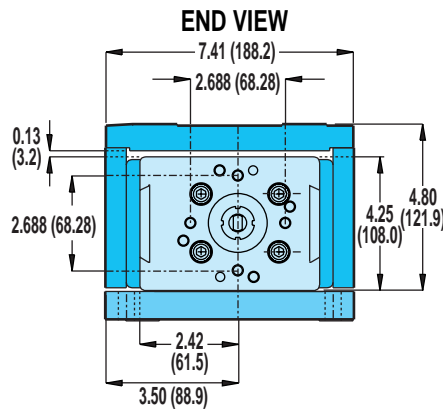
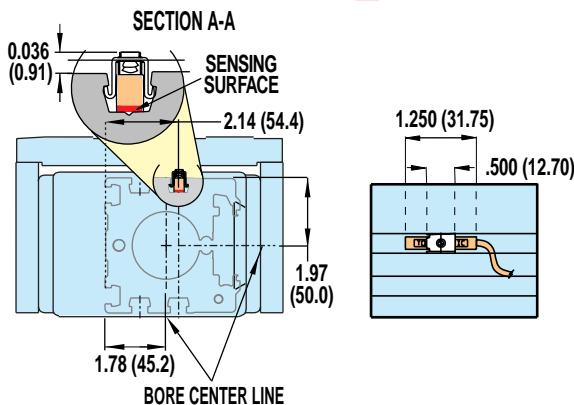

- ① DOWEL PINS \oplus .003 (08mm) M
- ② FOR EXTENDED SHAFT 2.11 (53.6)

⚠ CAUTION: DO NOT OVERTIGHTEN SWITCH HARDWARE WHEN INSTALLING

- ④ NOTE: The scored face of the switch indicates the sensing surface and must face toward the magnet

- ⑤ NOTE: Some actuators require switch mounting on a specific side of the actuator. Call Tol-O-Matic 1-800-328-2174 for details

Axi dyne® B3S/M3S20 Series

DIMENSIONS

B3S/M3S20: IN-LINE MOUNT FOR 23-FRAME STEPPER (MRS) OR BRUSHED DC (MRB) MOTORS (Not for use with gearhead reduction)

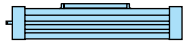

RODLESS

B3S/M3S20 Series
• In-line motor mounting dimensions

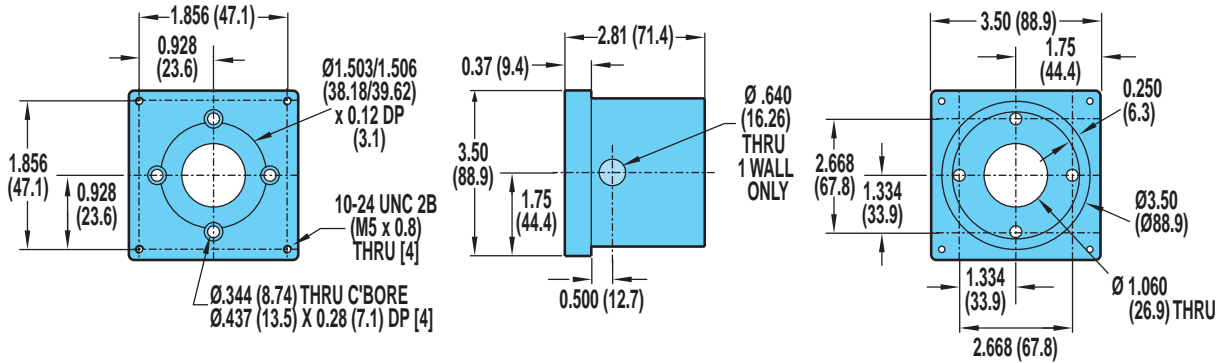

B3S/M3S20: IN-LINE MOUNT FOR 34-FRAME STEPPER (MRS) OR BRUSHED DC (MRB) MOTORS (Not for use with gearhead reduction)

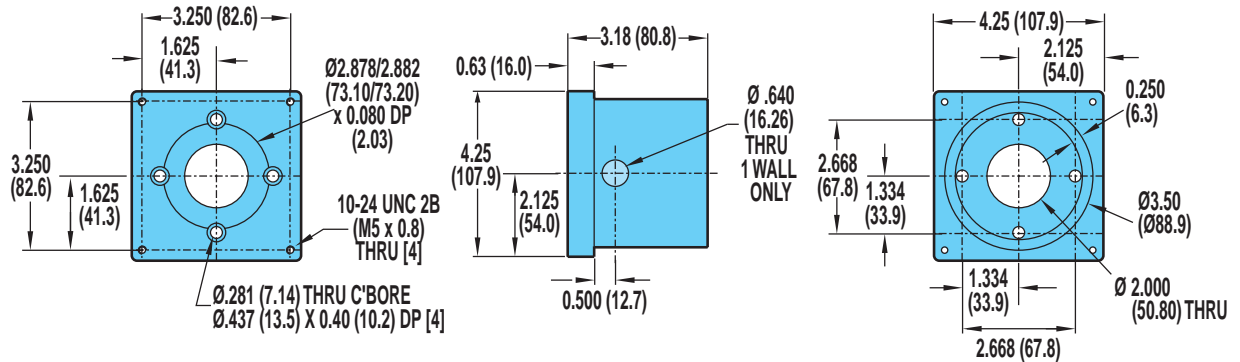

B3S/M3S20: IN-LINE MOUNT FOR BRUSHLESS SERVO (MRV) MOTORS, BRUSHED DC (MRB41,42) MOTORS OR GEARHEADS

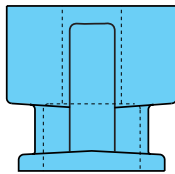

KEY

A → MRV31, 32, 33; GHK30, GHJ30, GHJ31
B → MRV21, 22, 23, 24
C → GHK20, GHJ20, GHJ21
D → MRB 41, MRB42



For a complete part listing of screw-drive motor and gearhead mounting kits referencing actuator/motor/coupler compatibilities, refer to document 3600-4631 available on the Literature/Part Sheet/Axidyne section of our web site at www.tolomatic.com.

For gearhead dimensions and specifications, refer to page F-10.

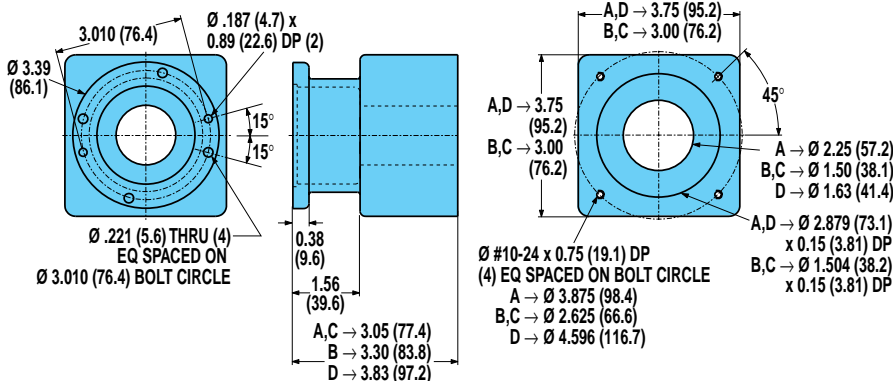

Axi-dyne® B3S/M3S20 Series

DIMENSIONS

B3S/M3S20: REVERSE PARALLEL MOUNTING

SIDE MOUNT (Right Shown)

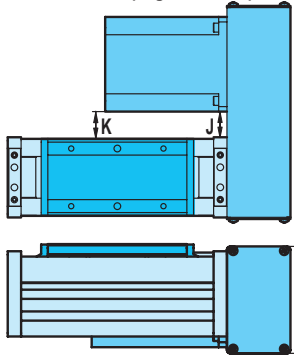

TOP MOUNT

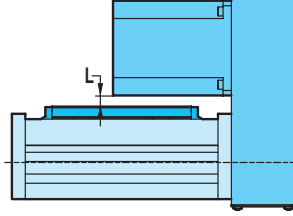

BOTTOM MOUNT

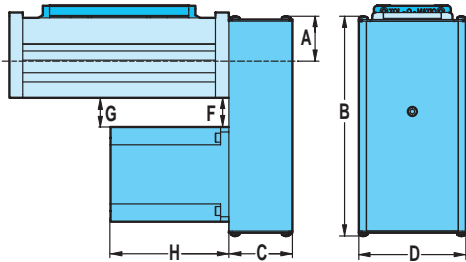

SPECIFICATIONS

MOTOR	WEIGHT OF REDUCTION DRIVE				REDUCTION INERTIA AT MOTOR SHAFT			
	1:1		2:1		1:1		2:1	
	lbs	kg	lbs	kg	lb-in ²	kg-m ² x 10 ⁻⁴	lb-in ²	kg-m ² x 10 ⁻⁴
BRUSHLESS MRV21, 22, 23, 24	3.07	1.39	3.23	1.47	2.46	720	2.07	605
BRUSHLESS MRV31, 32, 33	3.13	1.42	3.29	1.49	2.46	720	2.07	605
STEPPER MRS231, 232	2.93	1.33	3.09	1.40	1.40	410	1.01	295
STEPPER MRS341, 342, 343	3.02	1.37	3.18	1.44	1.46	427	1.06	310
BRUSHED MRB21	2.93	1.33	3.09	1.40	1.40	410	1.01	295
BRUSHED MRB31, 32	3.13	1.42	3.29	1.49	2.46	720	2.07	605
BRUSHED MRB41, 42	4.56	2.07	4.84	2.20	3.26	954	3.13	916

REDUCTION EFFICIENCY: 0.95

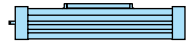

RODLESS

B3S/M3S20 Series
• Reverse parallel motor mounting

DIMENSIONS

MOTOR	A		B		C		D		F		G		H		J		K		L		
	in.	mm	in.	mm	in.	mm	in.	mm	in.	mm	in.	mm	in.	mm	in.	mm	in.	mm	in.	mm	
BRUSHLESS	MRV21	1.44	36.6	9.31	236.5	2.38	60.3	4.00	101.6	2.34	59.5	2.35	59.6	4.75	120.7	2.00	50.8	2.16	54.7	1.47	37.2
	MRV22	1.44	36.6	9.31	236.5	2.38	60.3	4.00	101.6	2.34	59.5	2.35	59.6	5.75	146.1	2.00	50.8	2.16	54.7	1.47	37.2
	MRV23	1.44	36.6	9.31	236.5	2.38	60.3	4.00	101.6	2.34	59.5	2.35	59.6	6.75	171.5	2.00	50.8	2.16	54.7	1.47	37.2
	MRV24	1.44	36.6	9.31	236.5	2.38	60.3	4.00	101.6	2.34	59.5	2.35	59.6	7.75	196.9	2.00	50.8	2.16	54.7	1.47	37.2
	MRV31	1.96	49.7	9.83	249.6	2.38	60.3	4.00	101.6	1.70	43.2	1.70	43.2	6.11	155.2	1.36	34.4	1.51	38.4	0.82	20.9
	MRV32	1.96	49.7	9.83	249.6	2.38	60.3	4.00	101.6	1.70	43.2	1.70	43.2	7.36	186.9	1.36	34.4	1.51	38.4	0.82	20.9
MRV33	1.96	49.7	9.83	249.6	2.38	60.3	4.00	101.6	1.70	43.2	1.70	43.2	8.61	218.7	1.36	34.4	1.51	38.4	0.82	20.9	
STEPPER	MRS231	1.44	36.6	9.31	236.5	2.38	60.3	4.00	101.6	2.34	59.5	2.35	59.6	2.06	52.3	2.00	50.8	2.16	54.7	1.47	37.2
	MRS232	1.44	36.6	9.31	236.5	2.38	60.3	4.00	101.6	2.34	59.5	2.35	59.6	3.10	78.7	2.00	50.8	2.16	54.7	1.47	37.2
	MRS341	1.96	49.7	9.83	249.6	2.38	60.3	4.00	101.6	1.78	45.2	1.78	45.2	2.58	65.5	1.44	36.4	1.59	40.4	0.90	22.9
	MRS342	1.96	49.7	9.83	249.6	2.38	60.3	4.00	101.6	1.78	45.2	1.78	45.2	3.76	95.5	1.44	36.4	1.59	40.4	0.90	22.9
MRS343	1.96	49.7	9.83	249.6	2.38	60.3	4.00	101.6	1.78	45.2	1.78	45.2	5.06	128.5	1.44	36.4	1.59	40.4	0.90	22.9	
BRUSHED	MRB21	1.44	36.6	9.31	236.5	2.38	60.3	4.00	101.6	2.34	59.5	2.35	59.6	6.33	160.8	2.00	50.8	2.00	54.7	1.47	37.2
	MRB31	1.96	49.7	9.83	249.6	2.38	60.3	4.00	101.6	1.84	46.7	1.84	46.8	5.07	128.8	1.50	38.0	1.50	41.9	0.96	24.4
	MRB32	1.96	49.7	9.83	249.6	2.38	60.3	4.00	101.6	1.84	46.7	1.84	46.8	7.72	196.1	1.50	38.0	1.50	41.9	0.96	24.4
	MRB41	2.34	59.5	10.21	259.4	2.59	65.9	5.00	127.0	1.47	37.3	1.47	37.4	10.63	270.0	1.13	28.6	1.13	32.5	0.59	15.0
	MRB42	2.34	59.5	10.21	259.4	2.59	65.9	5.00	127.0	1.47	37.3	1.47	37.4	11.63	295.4	1.13	28.6	1.13	32.5	0.59	15.0

Axi-dyne® B3S/M3S Screw Drives

ORDERING

BASE MODEL SPECIFICATIONS

B3SD 20 BNL02 SK36 LMI

OPTIONS SPECIFICATIONS

DC18 TS2 BM2 TN8



RODLESS

B3S/M3S Series
• Ordering

MODEL TYPE

B3S B3S Series English Screw Drive
B3SD B3S Series English Screw Drive with Dual 180° Carrier
M3S B3S Series Metric Screw Drive
M3SD B3S Series Metric Screw Drive with Dual 180° Carrier

TUBE BORE DIAMETER

10 1-inch (25 mm) bore
 15 1 1/2-inch (40 mm) bore
 20 2-inch (50 mm) bore

NUT/SCREW CONFIGURATION

ENGLISH MODELS

SOLID NUT / PITCH (turn/in)	SERIES
SN01	B3S(D)10, 15, 20
SN02	B3S(D)10, 15, 20
SNA02	B3S(D)10, 15
SN05	B3S(D)10

BALL NUT / PITCH (turn/in)	SERIES
BN02	B3S(D)15, 20
BNL02	B3S(D)15, 20
BN05	B3S(D)15, 20
BNL05	B3S(D)15, 20
BN08	B3S(D)10
BNL08	B3S(D)10

METRIC MODELS

SOLID NUT / LEAD (mm/turn)	SERIES
SN12	M3S(D)10, 15, 20
SN25	M3S(D)10, 15, 20

BALL NUT / LEAD (mm/turn)	SERIES
BN02	M3S(D)10
BNL02	M3S(D)10
BN05	M3S(D)15, 20
BNL05	M3S(D)15, 20

STROKE LENGTH

SK Stroke, then enter desired stroke length in decimal inches

MOTOR MOUNTING / REDUCTIONS

(must choose one)
LMI In-Line mounting
LME23 Ext. shaft for RP & 23 frame motor
LME34 Ext. shaft for RP & 34 frame motor
LME40 Ext. shaft for RP & 40 frame motor
***LMX** Extended shaft - old style (see note)
**For replacement actuators with extended motor shafts purchased prior to 6/24/02, use the LMX configuration code.*

⚠ A motor size and code must be selected when specifying a reverse-parallel mounting configuration. Reference the ordering pages in sections F, G and H for the motor types and selections.

RPL1 1:1 Reverse-Parallel mount left
RPR1 1:1 Reverse-Parallel mount right
RPB1 1:1 Reverse-Parallel mount bottom
RPT1 1:1 Reverse-Parallel mount top
RPL2 2:1 Reverse-Parallel mount left
RPR2 2:1 Reverse-Parallel mount right
RPB2 2:1 Reverse-Parallel mount bottom
RPT2 2:1 Reverse-Parallel mount top

AUXILIARY CARRIER

DC_ Auxiliary Carrier, then center-to-center spacing desired in decimal inches. (Center-to-Center spacing will add to overall dead length and will not subtract from the stroke length)

SUPPORTS AND MOUNTING PLATES

(both may be selected)
TS_ Tube Supports plus quantity desired
****MP_** Mounting Plates plus quantity desired

***Mounting plates are not available on B3SD Dual 180° models.*

SWITCHES

RM_ Reed Switch (Form A) with 5-meter lead/QD, and quantity desired
RT_ Reed Switch (Form A) with 5-meter lead, and quantity desired
BM_ Reed Switch (Form C) with 5-meter lead/QD, and quantity desired
BT_ Reed Switch (Form C) with 5-meter lead, and quantity desired
KM_ Hall-effect Sinking Switch with 5-meter lead/QD, and quantity desired
KT_ Hall-effect Sinking Switch with 5-meter lead, and quantity desired
TM_ Hall-effect Sourcing Switch with 5-meter lead/QD, and quantity desired
TT_ Hall-effect Sourcing Switch with 5-meter lead, and quantity desired
CM_ TRIAC Switch with 5-meter lead/QD, and quantity desired
CT_ TRIAC Switch with 5-meter lead, and quantity desired

T-NUTS

TN_ Additional T-Nuts and quantity

TO ORDER MOTORS/CONTROLS/INTERFACES

BRUSHLESS SERVO (SEE PAGE F-33)

MICROSTEPPING (SEE PAGE G-23)

BRUSHED DC (SEE PAGE H-26)

⚠ Not all codes listed are compatible with all options.

Use the Tol-O-Motion™ Sizing Software to determine available options and accessories based on your application requirements.

FIELD RETROFIT KITS						
ITEM	B3S10	B3S15	B3S20	M3S10	M3S15	M3S20
Tube Supports	3410-9006	3415-9006	3420-9006	4410-9006	4415-9006	4420-9006
Tube Supports (B3SD Dual 180° models)	3410-9026	3415-9026	3420-9026	4410-9026	4415-9026	4420-9026
1/2" Mounting Plates (MRB/MRS/MRV 23-frame motors)	3410-9056	3415-9056	—	3410-9056	3415-9056	—
1/2" Mounting Plates (MRB/MRS/MRV all frame motors)	—	—	3420-9056	—	—	3420-9056
1" Mounting Plates (MRB/MRS 23-frame; MRV all frame motors)	3410-9057	—	—	3410-9057	—	—
1" Mounting Plates (MRB/MRS/MRV 34-frame motors)	—	3415-9057	—	—	3415-9057	—

Axi-dyne® B3B/M3B Belt Drives



APPLICATION BENEFITS

- Accommodate heavy loads
- Handle high moment loads with consistent, smooth operation
- Cost-effective alternative to auxiliary rail systems
- Longer strokes
- Higher speeds

BEARING SYSTEM



- Heavy duty recirculating bearings in gothic arch rail guide
- Wear resistance with repeatable accuracy
- Patented * sealed bearing system—for long life
- High load and moment capacities
- Consistent tracking for full actuator life

STANDARD MOUNTING



- B3B actuators have T-nut mounting in the body base with four T-nuts for the first 24 inches of stroke. Two nuts are provided for each additional 20 inches.

ACTUATOR/MOTOR FACTORS

- Actuator's operating temperature range (40-130°F, 4-45° C) should take into consideration heat generated by the motor and drive, linear velocity and work cycle time.
- For large frame motors or small actuators, cantilevered motors need to be supported, if subjected to continuous rapid reversing duty and/or under dynamic conditions.

AVAILABLE OPTIONS



Tube Supports: Provide intermediate support of actuator body at the recommended intervals.



Auxiliary Carrier: Increases rigidity, load-carrying capacity and bending moments

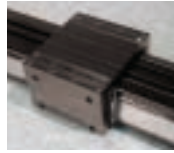

Dual 180° Carrier: Allows load to be rotated 90° from the cylinder's carrier, providing an additional load bearing surface. Requires its own proprietary tube supports and foot mounts.



Auxiliary Dual 180° Carrier: Substantially increases loads and moments.



Mounting Plates: Provide clearance height for motors and motor mounts when mounting an actuator on a flush surface and provide the means for top mounting access. Kits include plates and mounting screws.



Motor Mounting and Gearhead Reduction

Direct-Drive—Drive motor is mounted directly to the drive end assembly.



Reduction Drive—Mounts the motor to the reduction assembly, providing a 3:1 speed reduction from the motor to the belt drive wheel.



Gearheads—available for applications requiring reduction for inertia matching or higher torque at lower speeds. High efficiency, single stage, true planetary gearheads are available in 5.5:1 and 10:1 ratios for reduction solutions with most Tol-O-Matic NEMA 23 and 34 face motors.

For gearhead specifications and dimensions, see page F-10.

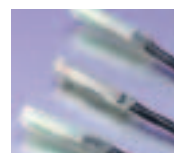

Switches: Reed, dc Hall-effect and ac TRIAC. See section I.

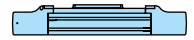

RODLESS

B3B/M3B Series

- Application benefits
- Bearing system
- Standard mounting
- Actuator/motor factors
- Available options

* U.S. Patent No. 5,555,789

Axi-dyne® B3B/M3B Belt Drives

BELT PERFORMANCE

BELT FORCE AND SPEED CAPACITIES

BELT LOAD FOR B3B/M3B ACTUATORS

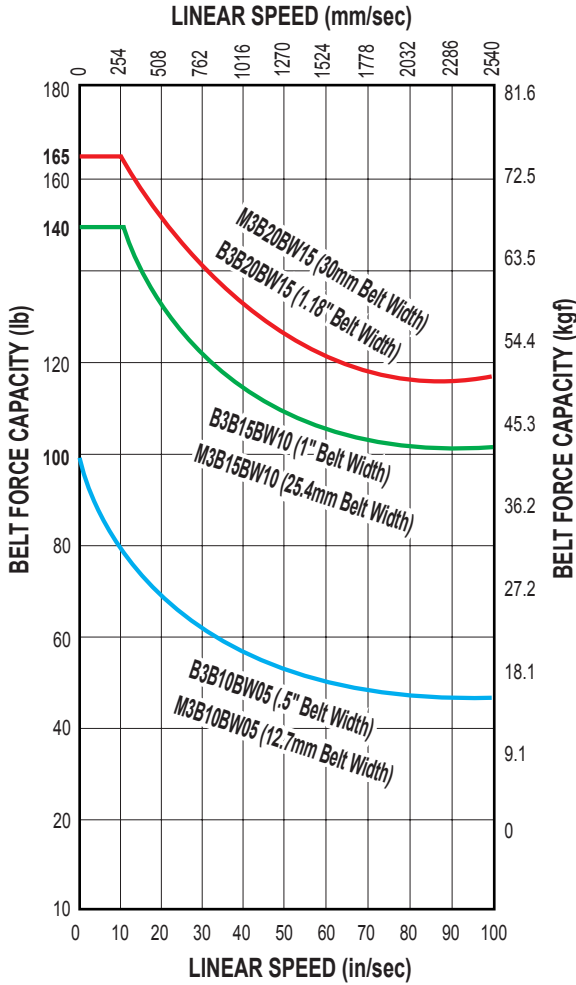

BELT SPEED FOR B3B/M3B ACTUATORS

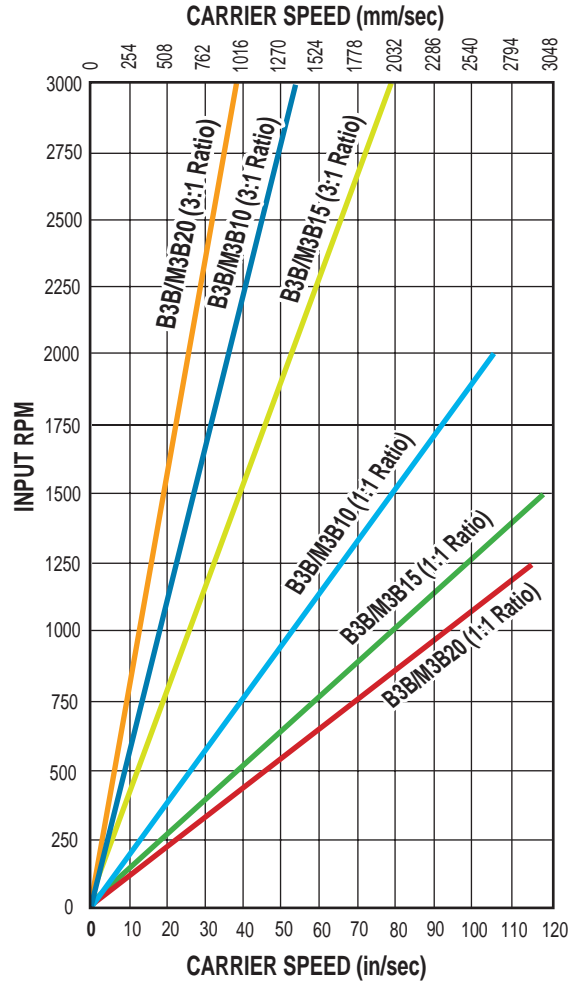

RODLESS

B3B/M3B Series

- Belt force and speed capacities
- Belt specifications

BELT SPECIFICATIONS

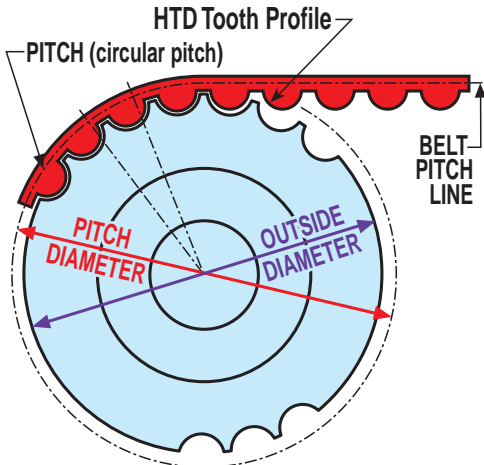

STYLE:	HTD Tooth
TOOTH PITCH:	5mm
BELT MATERIAL:	Neoprene body with Fiberglass tension members
CHARACTERISTICS:	For higher speed, higher load applications Heavy duty drive and idler pulley bearings

Axi-dyne® B3B Belt Drives

OVERALL SERIES SPECIFICATIONS

B3B/M3B BELT, INERTIA AND BREAKAWAY TORQUE SPECIFICATIONS

B3B ENGLISH ACTUATORS								
ACTUATOR SERIES	BELT WIDTH (in)	BELT WEIGHT (lb/in)	BELT DEAD LENGTH (in)	WHEEL PITCH DIA. (in)	PULLEY WHEELS INERTIA (lb-sq in)	INERTIA (lb-in ²)		BREAKAWAY TORQUE (LB-IN)
						BASE ACTUATOR	PER/INCH OF STROKE	
B3B10	.50	.0028	20.10	1.003	.031	0.2846	0.0016	5.000
B3B15	1.00	.0056	30.80	1.504	.303	1.3917	0.0017	10.000
B3B20	1.18	.0066	31.90	1.754	.651	2.6607	0.0114	15.625



RODLESS

B3B/M3B Series

- Belt, inertia and breakaway torque specifications
- General actuator specifications

M3B METRIC ACTUATORS								
ACTUATOR SERIES	BELT WIDTH (mm)	BELT WEIGHT (g/cm)	BELT DEAD LENGTH (mm)	WHEEL PITCH DIA. (mm)	PULLEY WHEELS INERTIA (kg-sq M x 10 ⁻⁶)	INERTIA (kg-m ² x 10 ⁻⁶)		BREAKAWAY TORQUE (N-m)
						BASE ACTUATOR	PER/mm OF STROKE	
M3B10	12.7	1.27	510.5	25.5	0.000009	83.25	0.47	0.56
M3B15	25.4	2.54	782.3	38.2	0.000886	407.07	0.50	1.13
M3B20	29.9	2.99	810.3	44.6	0.001905	778.25	0.33	1.77

GENERAL ACTUATOR SPECIFICATIONS

B3B ENGLISH ACTUATORS							
ACTUATOR SERIES	MAXIMUM STROKE (in)	CARRIER WEIGHT (lb)	BASE WEIGHT (lb) (Including Carrier)	WEIGHT PER/in OF STROKE (lb)	STRAIGHTNESS & FLATNESS (in) ¹ (Constrained)	TEMP. RANGE ² (F°)	IP RATING ³
B3B10	292	0.85	7.54	.388	0.00067 x L*	40 - 130	44
B3B15	292	1.56	25.12	.394	0.00067 x L*	40 - 130	44
B3B20	292	2.14	35.40	.714	0.00067 x L*	40 - 130	44

M3B METRIC ACTUATORS							
ACTUATOR SERIES	MAXIMUM STROKE (mm)	CARRIER WEIGHT (kg)	BASE WEIGHT (kg)	WEIGHT PER/mm OF STROKE (g)	STRAIGHTNESS & FLATNESS (mm) (Constrained)	TEMP. RANGE* (C°)	IP RATING**
M3B10	7417	0.40	1.00	6.43	0.00067 x L*	4 - 54	44
M3B15	7417	0.70	3.96	7.04	0.00067 x L*	4 - 54	44
M3B20	7417	0.97	6.52	12.75	0.00067 x L*	4 - 54	44



¹ The listed values relating to straightness/flatness are intended for reference purposes only, and not as an engineering standard of absolute tolerance for a given actuator. Appropriate installation is the single most important factor in reducing such deviation, so good engineering practices such as measurement, mapping, etc. must be employed in applications with stringent straightness/flatness requirements.

² Heat generated by the motor and drive should be taken into consideration as well as linear velocity and work cycle time. For applications that require operation outside of the recommended temperature range, contact the factory.

³ Protected against ingress of solid particles greater than .039 in (1mm) and splashing water.

* "L" is maximum distance between supports— See the support recommendation diagram on page C-34.

LARGE FRAME MOTORS AND SMALLER SIZE ACTUATORS: Cantilevered motors need to be supported, if subjected to continuous rapid reversing duty and/or under dynamic conditions.

Axi-dyne® B3B/M3B Belt Drives

OVERALL SERIES SPECIFICATIONS

FRICITION FORCE

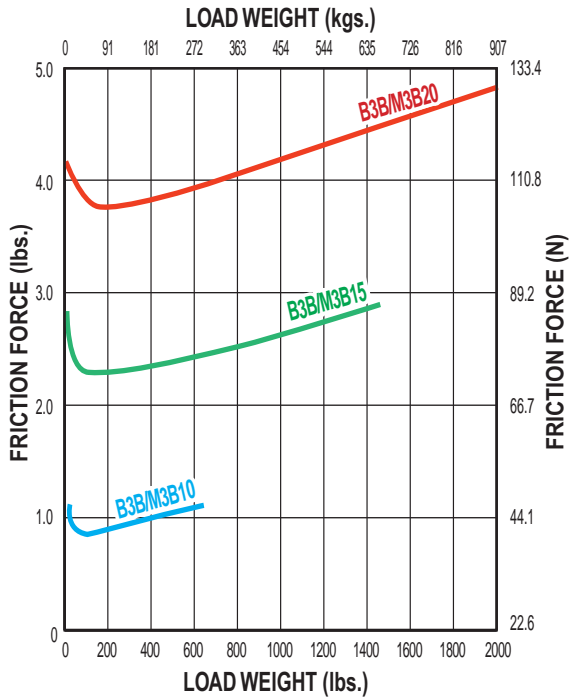

RODLESS

B3B/M3B Series

- Friction force
- Support recommendations

SUPPORT RECOMMENDATIONS

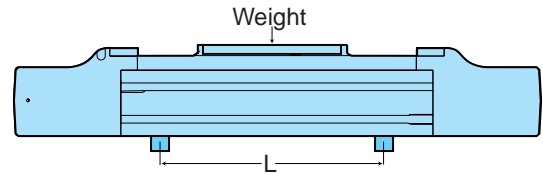
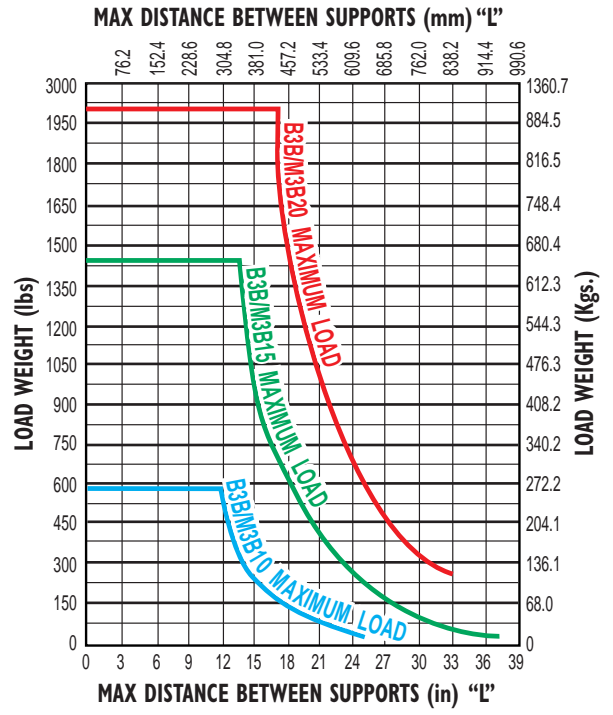

Axi-dyne® B3B Belt Drives

OVERALL SERIES SPECIFICATIONS

DYNAMIC BENDING MOMENTS AND LOADS

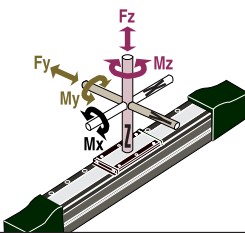
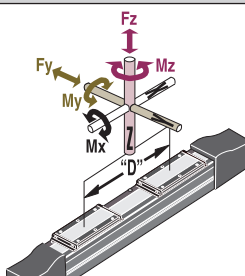
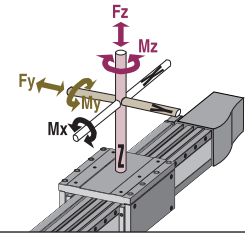
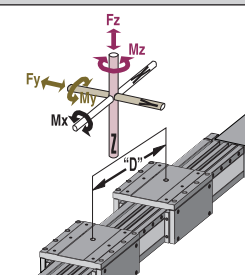
STANDARD CARRIER	MAXIMUM BENDING MOMENTS AND LOADS		ENGLISH			METRIC		
			B3B10	B3B15	B3B20	M3B10	M3B15	M3B20
	Mx Moment (Roll)	(lb-in : N-m)	250	859	1662	28.2	97.1	187.8
	My Moment (Pitch)	(lb-in : N-m)	269	1033	1472	30.4	116.7	166.3
	Mz Moment (Yaw)	(lb-in : N-m)	156	596	850	17.9	67.3	96.0
	Fy Load (Radial)	(lb : N)	341	840	1159	1517	3738	5158
	Fz Load (Lateral)	(lb : N)	591	1454	2008	2630	6470	8936
AUXILIARY CARRIER: Increases rigidity, load-carrying capacity and moments			B3B10	B3B15	B3B20	M3B10	M3B15	M3B20
	Mx Moment (Roll)	*(lb-in : N-m)	500	1718	3324	56.5	194.1	375.6
	My Moment (Pitch)	*(lb-in : N-m)	2825	11,734	16,265	319.2	1325.8	1837.8
	Mz Moment (Yaw)	*(lb-in : N-m)	1630	6779	9388	184.2	765.9	1060.8
	Fy Load (Radial)	(lb : N)	682	1680	2318	3035	7476	10315
	Fz Load (Lateral)	(lb : N)	1182	2908	4016	5260	1294	17871
	Minimum Dimension 'D'	(in : mm)	4.88	8.07	8.10	124.0	205.0	205.7
DUAL 180° CARRIER: Allows 90° rotation of load, adds load bearing surface			B3B10	B3B15	B3B20	M3B10	M3B15	M3B20
	Mx Moment (Roll)	(lb-in : N-m)	657	2468	4527	74.2	278.9	511.2
	My Moment (Pitch)	(lb-in : N-m)	312	1192	1700	35.3	134.7	192.1
	Mz Moment (Yaw)	(lb-in : N-m)	538	2066	2944	60.8	233.4	332.6
	Fy Load (Radial)	(lb : N)	1182	2908	4016	5260	1294	17871
	Fz Load (Lateral)	(lb : N)	682	1680	2318	3035	7476	10315
AUXILIARY DUAL 180° CARRIER: Substantially increases moment and loads			B3B15	B3B20	M3B10	M3B15	M3B20	
	Mx Moment (Roll)	*(lb-in : N-m)	1314	4936	9054	147	553	1014
	My Moment (Pitch)	*(lb-in : N-m)	3328	13558	18776	373	1518	2103
	Mz Moment (Yaw)	*(lb-in : N-m)	5768	23468	32530	646	2628	3643
	Fy Load (Radial)	(lb : N)	2364	5816	8032	1072	2638	3643
	Fz Load (Lateral)	(lb : N)	1364	3360	4636	619	1524	2103
	Minimum Dimension 'D'	(in : mm)	4.88	8.07	8.10	124.0	205.0	205.7



RODLESS

B3B/M3B Series

• Bending moments and loads



The Dual 180° carrier requires its own proprietary tube supports and foot mounts. See dimensional information. Breakaway torque will also increase when using the Auxiliary carrier or the Dual 180° carrier options. When ordering, determine your working stroke and enter this value into the configuration string. Overall actuator length will automatically be calculated.

Deflection Considerations: In applications where substantial Mx or My moments come into play, deflection of the cylinder tube, carrier and supports must be considered. The deflection factors shown in the Load Deflection charts on the following page, are based on cylinder mounted with tube supports at minimum recommended spacing. If more rigidity is desired, refer to the Auxiliary or Dual Carrier options.

**Loads shown in table are at minimum "D" dimension, for ratings with longer "D" dimension see graph on page C-37.*

Axi-dyne® B3B/M3B Belt Drives

OVERALL SERIES SPECIFICATIONS

LOAD DEFLECTION

Y-AXIS DEFLECTION

Figures calculated with the following considerations:

- 1.) Tube supports spaced at minimum distances for each bore size
- 2.) Measurement distance from F to center of carrier is 13 inches

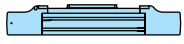

RODLESS

B3B/M3B Series

• Load deflection

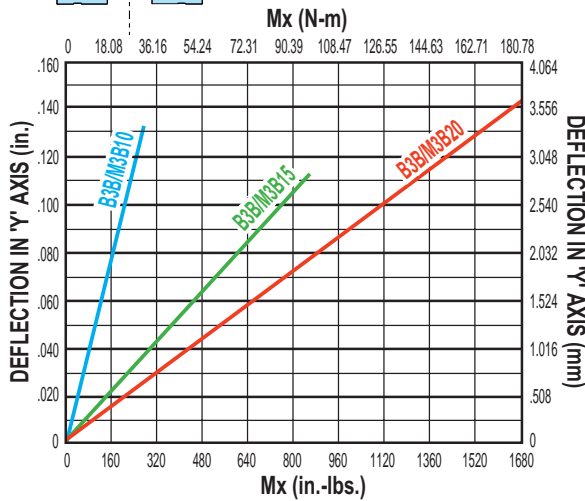
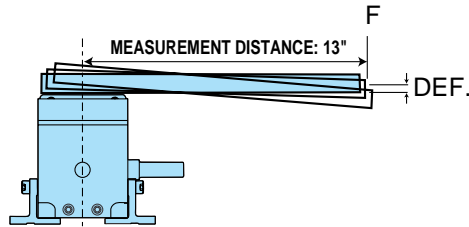

X-AXIS DEFLECTION

Figures calculated with the following considerations:

- 1.) Tube supports spaced at minimum distances for each bore size
- 2.) Measurement distance from F to center of carrier is 8 inches

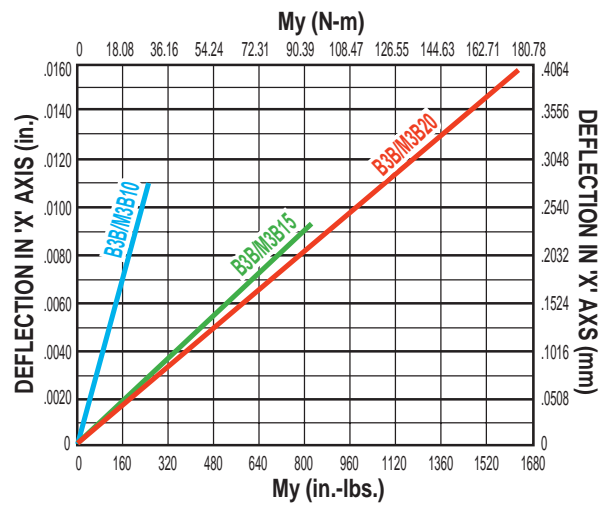
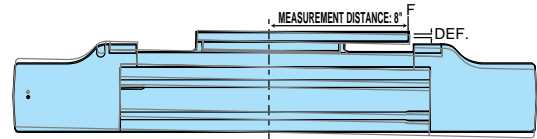

Axi-dyne® B3B/M3B Belt Drives

OVERALL SERIES SPECIFICATIONS

AUXILIARY CARRIER: BENDING MOMENT AT 'D' DISTANCE

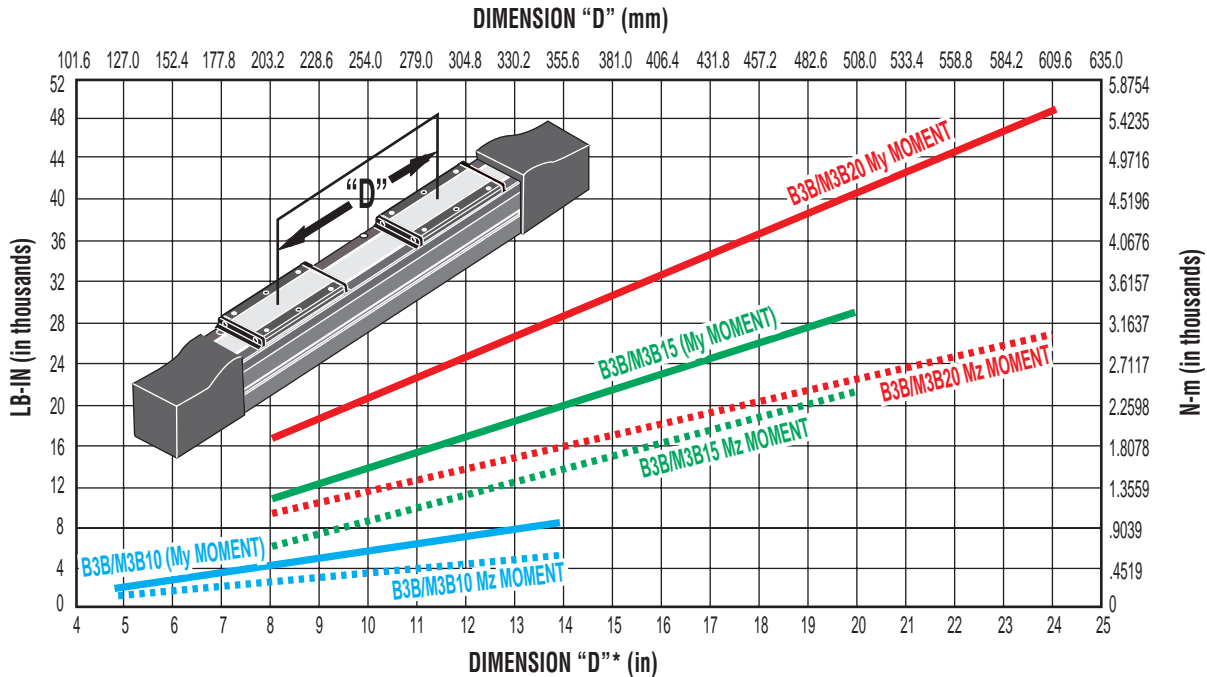

RODLESS

B3B/M3B Series

- Auxiliary carrier specifications
- Auxiliary dual 180° carrier specifications

- Rates shown on charts were calculated with these assumptions:
- 1.) Coupling between carriers is rigid.
 - 2.) Load is equally distributed between carriers.
 - 3.) Coupling device applies no misalignment loads to carriers.

* Customer must specify Dimension "D" (Distance between carrier center lines) in configuration string.

AUXILIARY DUAL 180° CARRIER: BENDING MOMENT AT 'D' DISTANCE

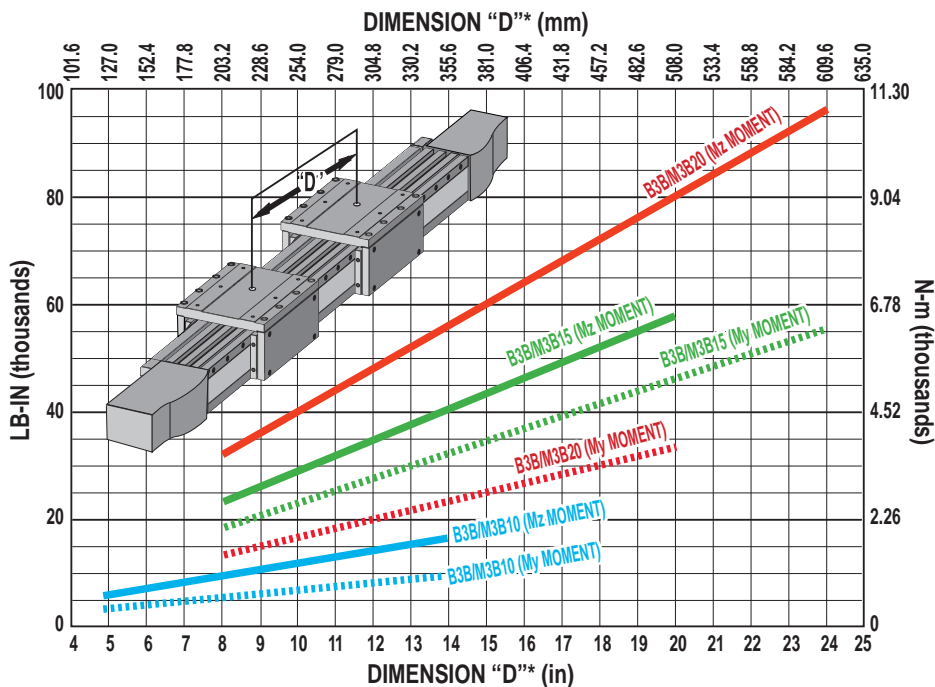

- Rates shown on charts were calculated with these assumptions:
- 1.) Coupling between carriers is rigid.
 - 2.) Load is equally distributed between carriers.
 - 3.) Coupling device applies no misalignment loads to carriers.

* Customer must specify Dimension "D" (Distance between carrier center lines) in configuration string.

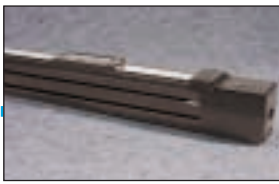

Axi dyne® B3B/M3B10 Series

BELT LOAD AND SPEED

B3B/M3B10 BELT LOAD



RODLESS

B3B/M3B10 Series

- Belt load
- Belt speed

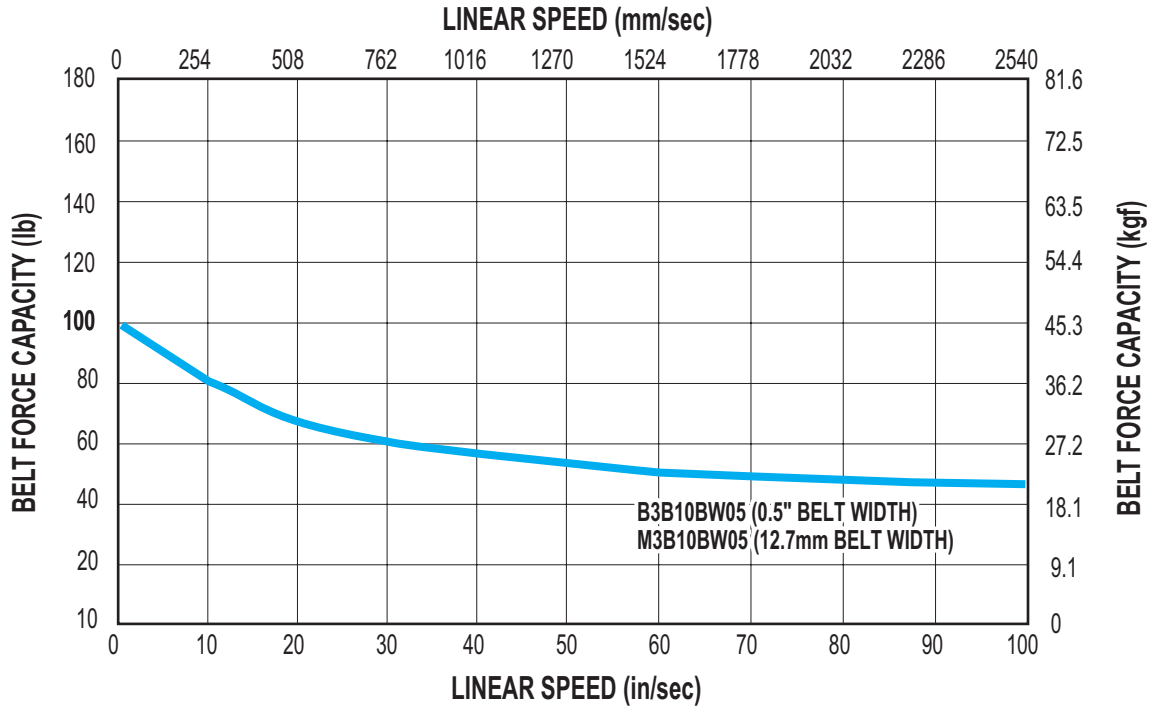

B3B/M3B10 BELT SPEED

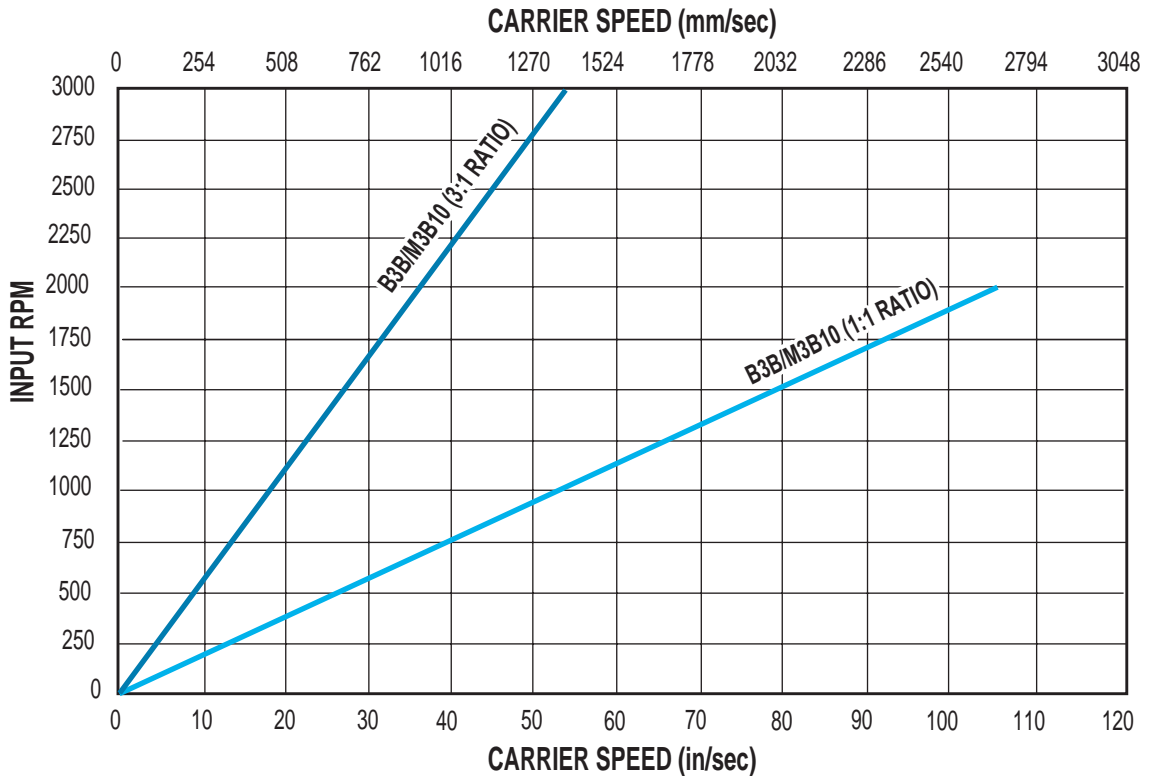

Axi-dyne® B3B/M3B I0 Series

DIMENSIONS

B3B/M3B I0 ACTUATOR AND OPTIONS

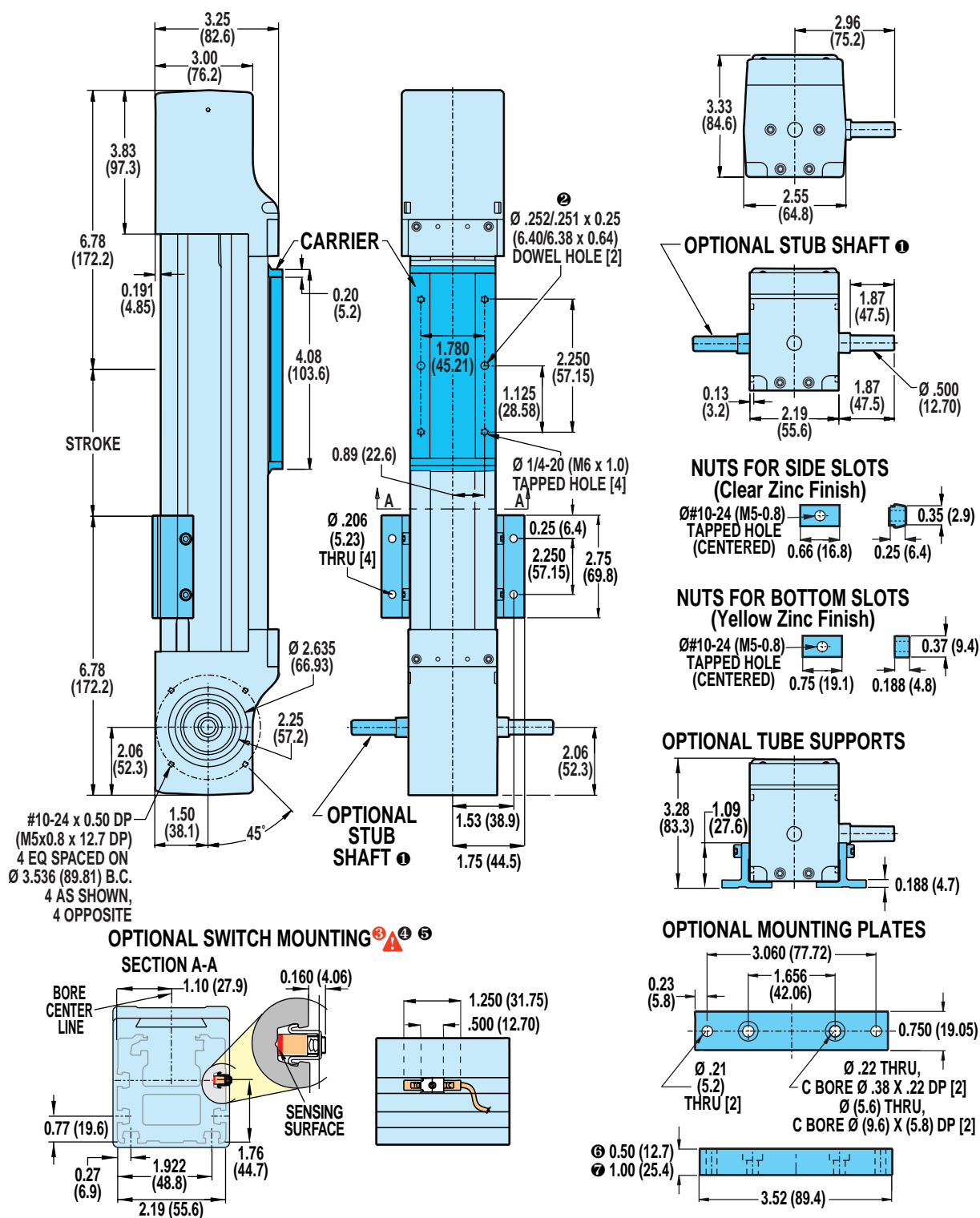

RODLESS

B3B/M3B I0 Series

• Actuator and options dimensions

❶ ONE STUB SHAFT IS STANDARD ON ALL B3B ACTUATORS

⚠ CAUTION: DO NOT OVERTIGHTEN SWITCH HARDWARE WHEN INSTALLING

❷ NOTE: Some actuators require switch mounting on a specific side of the actuator. Call Tol-O-Matic 1-800-328-2174 for details

❸ DOWEL PINS $\varnothing .003$ (08mm)

❹ NOTE: The scored face of the switch indicates the sensing surface and must face toward the magnet

❺ WHEN USED WITH 23-FRAME MOTORS

❻ WHEN USED WITH 34-FRAME MOTORS

Unless otherwise noted, all dimensions shown are in inches (Dimensions in parenthesis are in millimeters)

Axi dyne® B3B/M3B I0 Series

DIMENSIONS

B3BD/M3BD I0 DUAL 180° OPTION



RODLESS

B3B/M3B I0 Series

• Dual 180° carrier dimensions

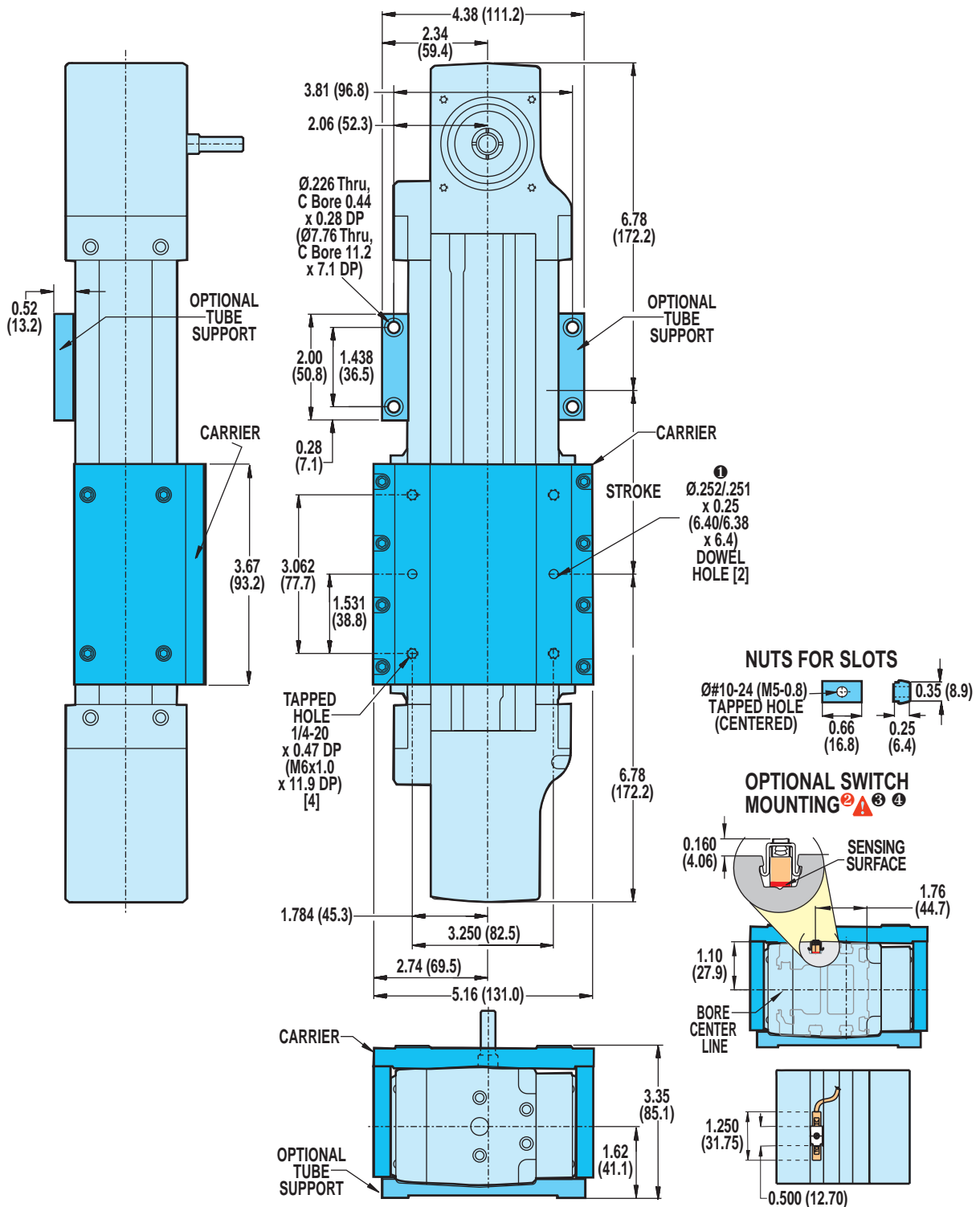

Axi-dyne® B3B/M3B I0 Series

DIMENSIONS

B3B(D)/M3B(D) I0 DIRECT DRIVE MOTOR MOUNTING

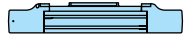
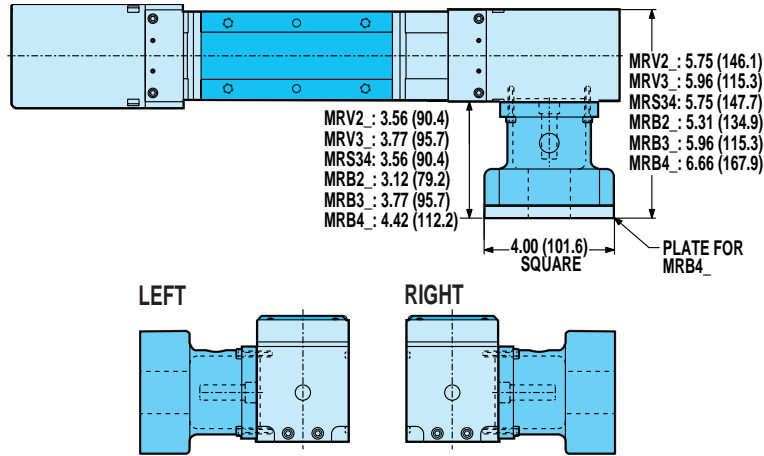

RODLESS

B3B/M3B I0 Series

- Direct drive motor mounting
- Reduction drive motor mounting

B3B(D)/M3B(D) I0 REDUCTION DRIVE MOTOR MOUNTING

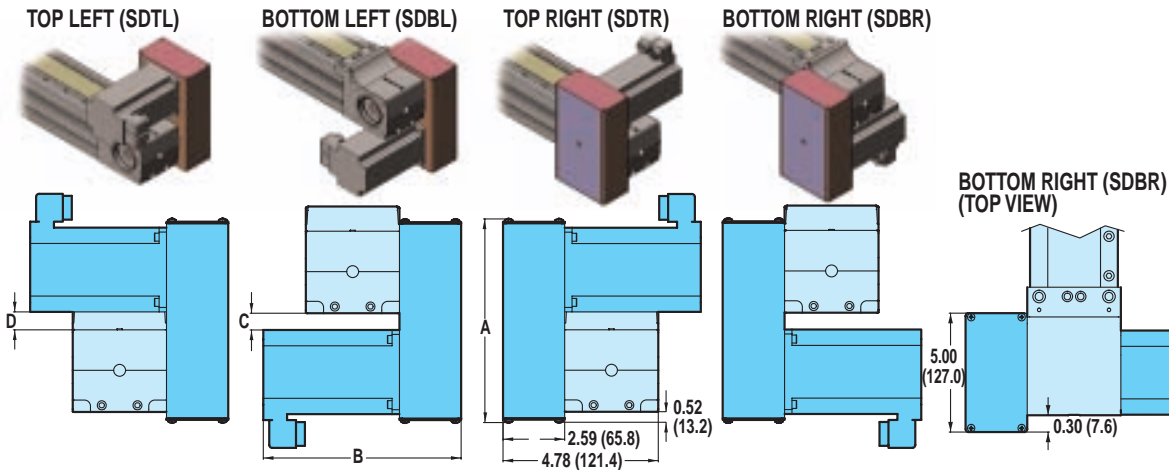

DIMENSIONS

	MOTOR	A		B		C		D	
		in.	mm	in.	mm	in.	mm	in.	mm
BRUSHLESS	MRV21	7.98	202.6	7.34	186.4	1.60	40.6	1.60	40.6
	MRV22	7.98	202.6	8.34	211.8	1.60	40.6	1.60	40.6
	MRV23	7.98	202.6	9.34	237.2	1.60	40.6	1.60	40.6
	MRV24	7.98	202.6	10.34	262.6	1.60	40.6	1.60	40.6
	MRV31	8.49	215.6	8.70	221.0	0.95	24.1	0.95	24.1
	MRV32	8.49	215.6	9.95	252.7	0.95	24.1	0.95	24.1
	MRV33	8.49	215.6	11.20	284.5	0.95	24.1	0.95	24.1
STEPPER	MRS231	7.98	202.6	4.65	118.1	1.60	40.6	3.25	82.6
	MRS232	7.98	202.6	5.69	144.5	1.60	40.6	3.25	82.6
	MRS341	8.49	215.6	5.17	131.3	1.04	26.4	1.04	26.4
	MRS342	8.49	215.6	6.35	161.3	1.04	26.4	1.04	26.4
MRS343	8.49	215.6	7.65	194.3	1.04	26.4	1.04	26.4	
BRUSHED	MRB21	7.98	202.6	8.92	226.6	1.60	40.6	1.60	40.6
	MRB31	8.49	215.6	7.66	194.6	1.09	27.7	1.09	27.7
	MRB32	8.49	215.6	10.31	261.9	1.09	27.7	1.09	27.7
	MRB41	8.85	224.8	13.22	335.8	0.72	18.3	0.72	18.3
	MRB42	8.85	224.8	14.22	361.2	0.72	18.3	0.72	18.3

SPECIFICATIONS

	MOTOR	WEIGHT OF REDUCTION DRIVE		REDUCTION INERTIA AT MOTOR SHAFT	
		lb	kg	lb-in ²	kg-m ² x 10 ⁻⁴
BRUSHLESS	MRV21, 22, 23, 24	3.40	1.54	0.229	66.98
	MRV31, 32, 33	3.92	1.78	0.229	66.98
STEPPER	MRS231, 232	3.33	1.51	0.144	42.12
	MRS341, 342, 343	3.84	1.76	0.199	58.21
BRUSHED	MRB21	3.33	1.51	0.208	60.84
	MRB31, 32	3.92	1.78	0.229	66.98
	MRB41, 42	4.62	2.10	0.226	66.11

3:1 REDUCTION EFFICIENCY: 0.95

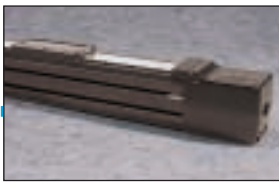

Axi dyne® B3B/M3B15 Series

BELT LOAD AND SPEED

B3B/M3B15 BELT LOAD

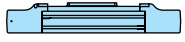

RODLESS

B3B/M3B15 Series

- Belt load
- Belt speed

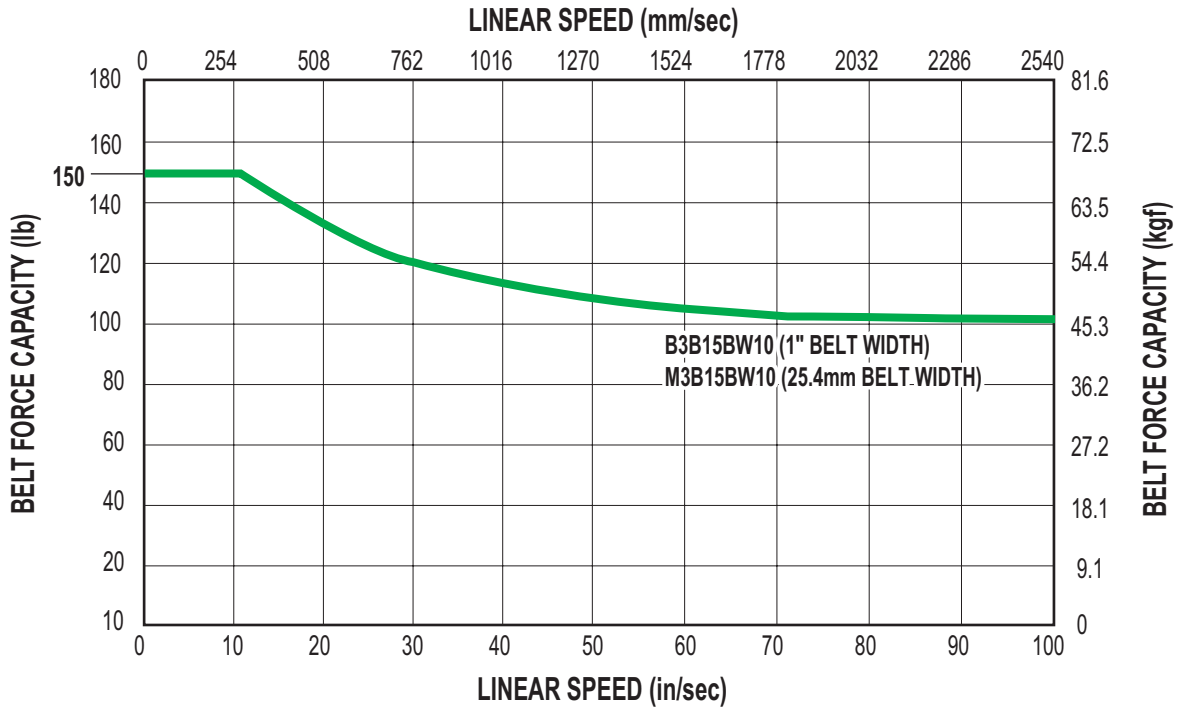

B3B/M3B15 BELT SPEED

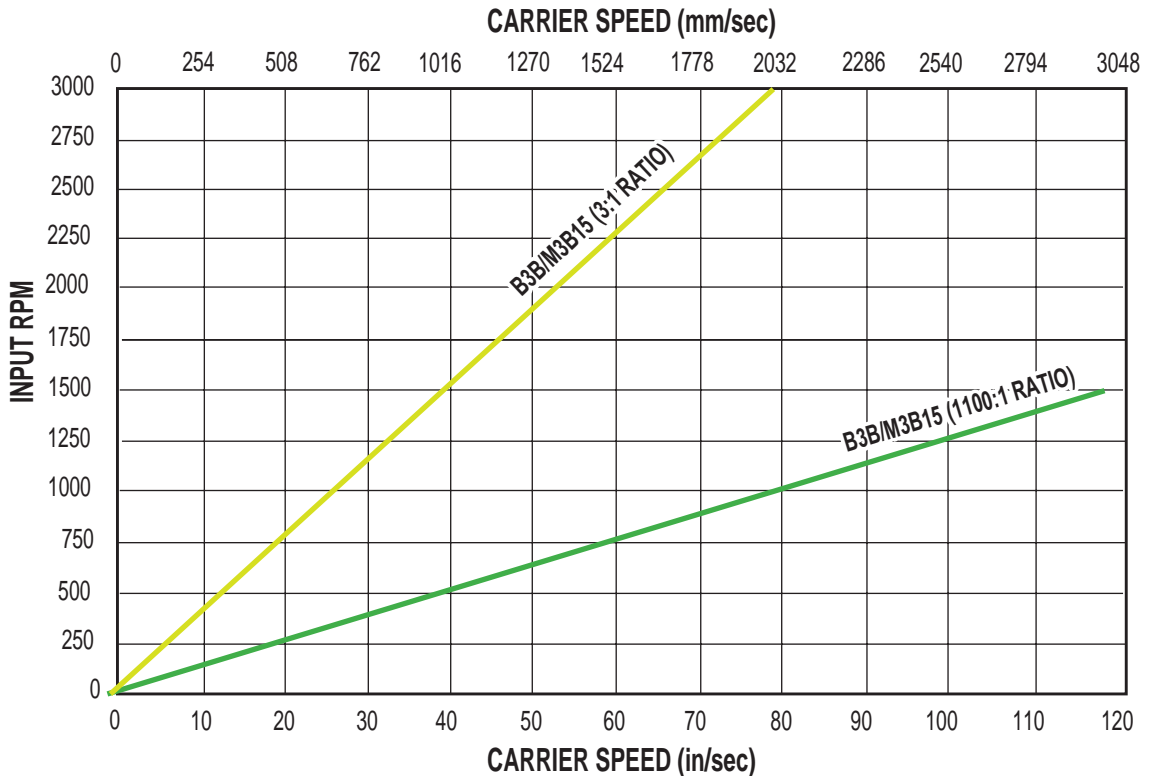

Axi-dyne® B3B/M3B I5 Series

DIMENSIONS

B3B/M3B I5 ACTUATOR AND OPTIONS

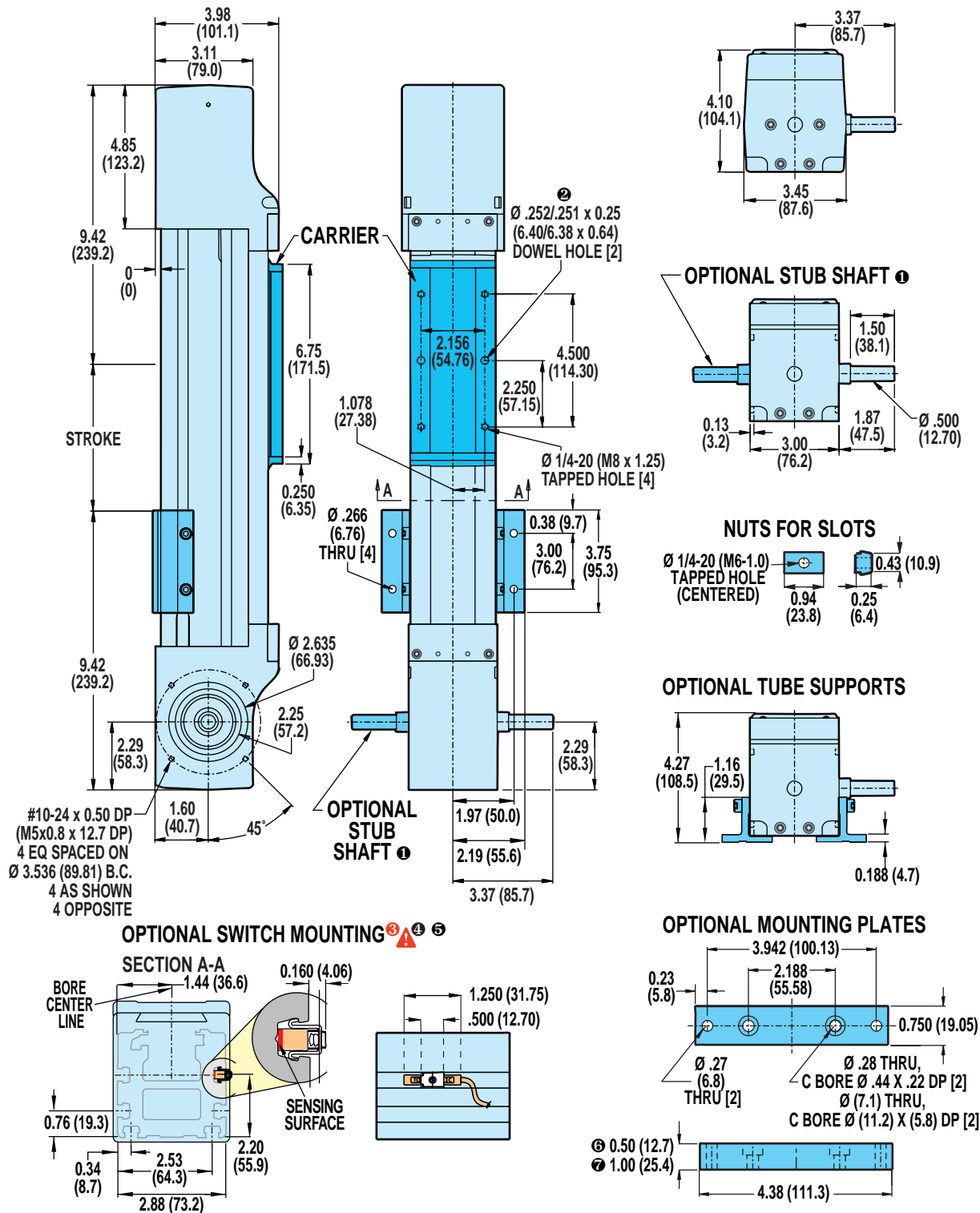

Unless otherwise noted, all dimensions shown are in inches (Dimensions in parenthesis are in millimeters)

Axi dyne® B3B/M3B I5 Series

DIMENSIONS

B3BD/M3BD I5 DUAL 180° OPTION

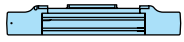

RODLESS

B3B/M3B I5 Series

• Dual 180° carrier
option dimensions

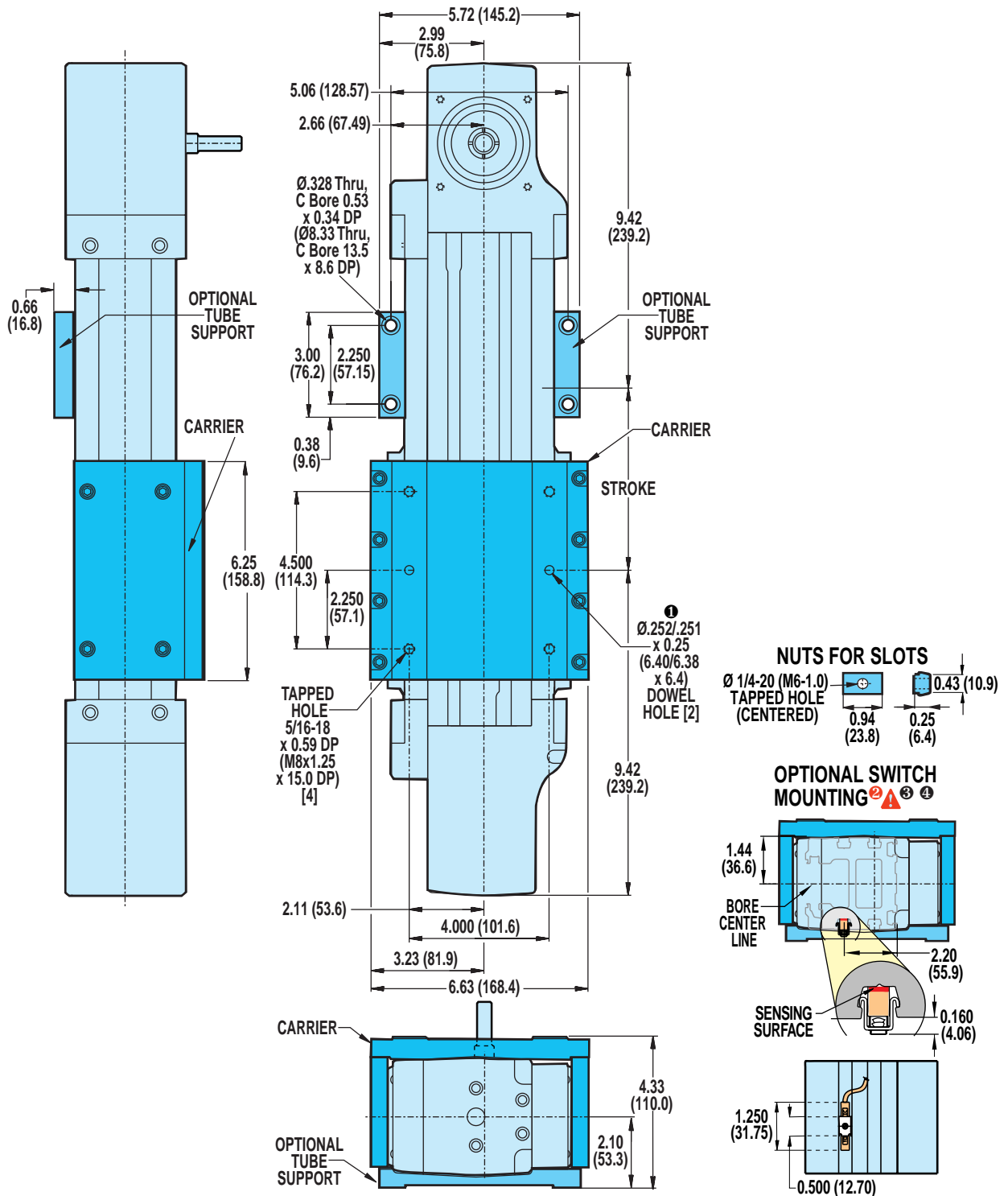

① DOWEL PINS \oplus .003 (08mm) M

Ⓝ NOTE: The scored face of the switch indicates the sensing surface and must face toward the magnet

Ⓞ NOTE: Some actuators require switch mounting on a specific side of the actuator. Call Tol-O-Matic 1-800-328-2174 for details

⚠ CAUTION: DO NOT OVERTIGHTEN SWITCH HARDWARE WHEN INSTALLING

Axi-dyne® B3B/M3B I5 Series

DIMENSIONS

B3B(D)/M3B(D) I5 DIRECT DRIVE MOTOR MOUNTING

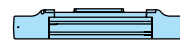
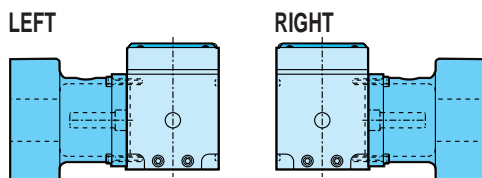
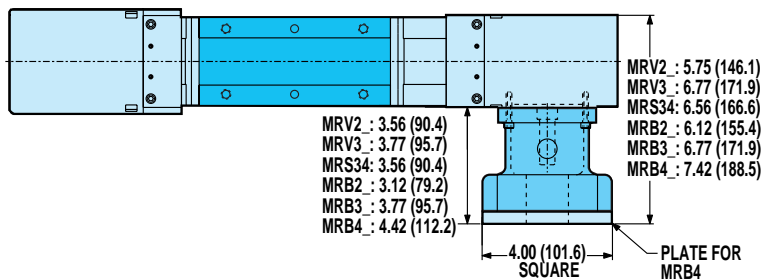

RODLESS

B3B/M3B I5 Series

- Direct drive motor mounting dimensions
- Reduction drive motor mounting dimensions

B3B(D)/M3B(D) I5 REDUCTION DRIVE MOTOR MOUNTING

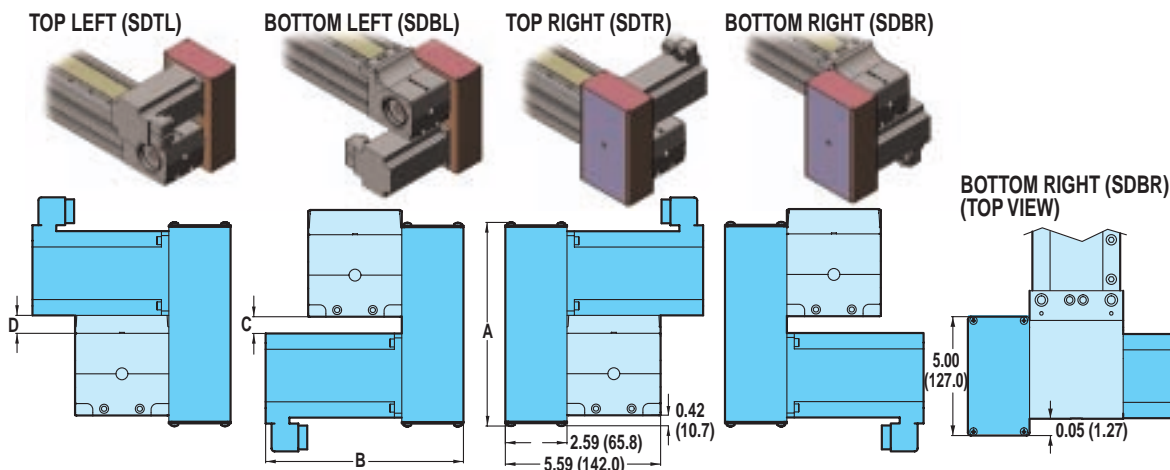

DIMENSIONS

	MOTOR	A		B		C		D	
		in.	mm	in.	mm	in.	mm	in.	mm
BRUSHLESS	MRV21	7.98	202.6	7.34	186.4	1.50	31.8	1.59	40.4
	MRV22	7.98	202.6	8.34	211.8	1.50	31.8	1.59	40.4
	MRV23	7.98	202.6	9.34	237.2	1.50	31.8	1.59	40.4
	MRV24	7.98	202.6	10.34	262.6	1.50	31.8	1.59	40.4
STEPPER	MRV31	8.49	215.6	8.70	221.0	0.85	21.6	0.95	24.1
	MRV32	8.49	215.6	9.95	252.7	0.85	21.6	0.95	24.1
	MRV33	8.49	215.6	11.20	284.5	0.85	21.6	0.95	24.1
BRUSHED	MRS341	8.49	215.6	5.17	131.3	0.93	23.6	1.03	26.2
	MRS342	8.49	215.6	6.35	161.3	0.93	23.6	1.03	26.2
	MRS343	8.49	215.6	7.65	194.3	0.93	23.6	1.03	26.2
	MRB21	7.98	202.6	8.92	226.6	1.50	31.8	1.59	40.4
	MRB31	8.49	215.6	7.66	194.6	0.99	25.1	1.09	27.7
	MRB32	8.49	215.6	10.31	261.9	0.99	25.1	1.09	27.7
	MRB41	8.85	224.8	13.22	335.8	0.62	15.7	0.72	18.3
	MRB42	8.85	224.8	14.22	361.2	0.62	15.7	0.72	18.3

SPECIFICATIONS

	MOTOR	WEIGHT OF REDUCTION DRIVE		REDUCTION INERTIA AT MOTOR SHAFT	
		lb	kg	lb-in ²	kg-m ² x 10 ⁻⁴
BRUSHLESS	MRV21, 22, 23, 24	3.40	1.54	0.229	66.98
	MRV31, 32, 33	3.92	1.78	0.229	66.98
STEPPER	MRS341, 342, 343	3.84	1.76	0.199	58.21
BRUSHED	MRB21	3.33	1.51	0.208	60.84
	MRB31, 32	3.92	1.78	0.229	66.98
	MRB41, 42	4.62	2.10	0.226	66.11

3:1 REDUCTION EFFICIENCY: 0.95

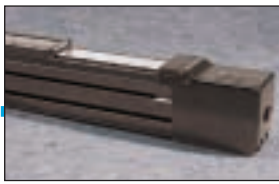

Axi dyne® B3B/M3B20 Series

BELT LOAD AND SPEED

B3B/M3B20 BELT LOAD



RODLESS

B3B/M3B20 Series

- Belt load
- Belt speed

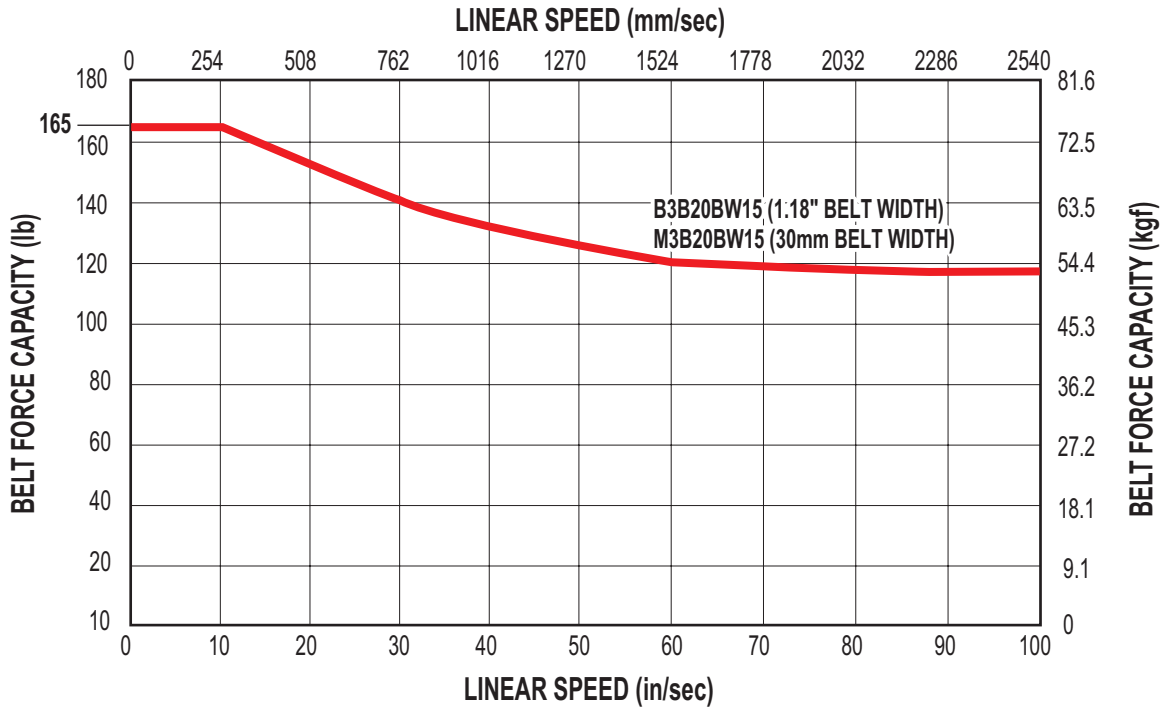

B3B/M3B20 BELT SPEED

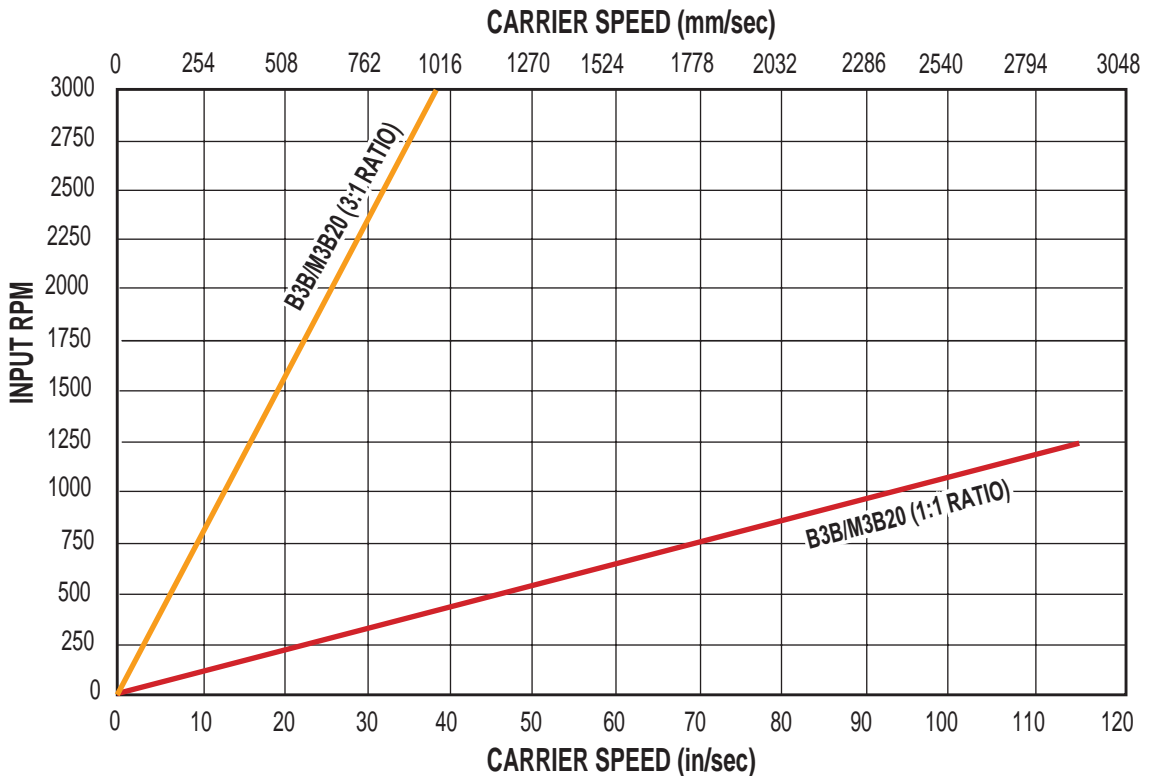

Axi-dyne® B3B/M3B20 Series

DIMENSIONS

B3B/M3B20 ACTUATOR AND OPTIONS

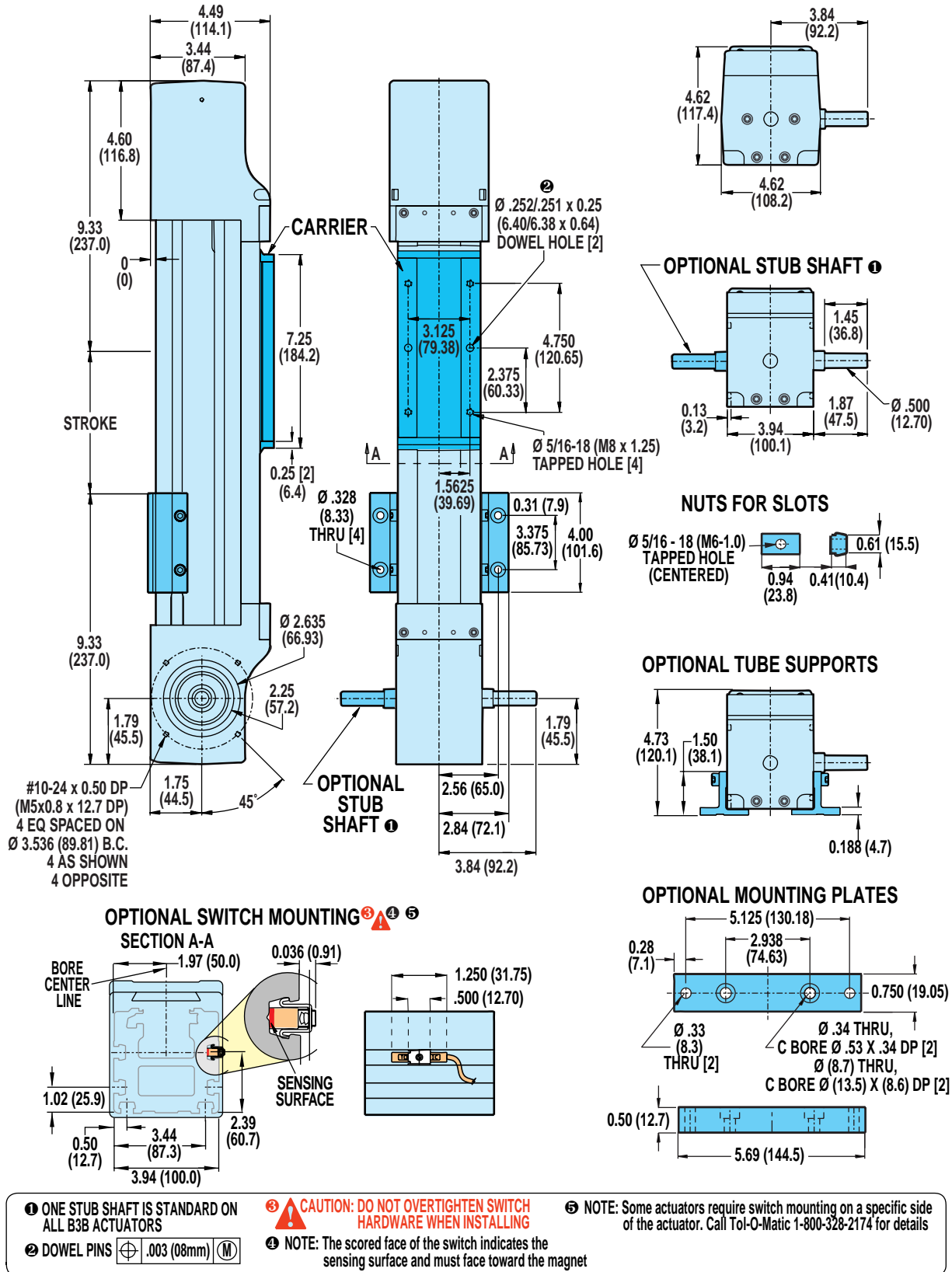

RODLESS

B3B/M3B20 Series
• Actuator and option dimensions

Unless otherwise noted, all dimensions shown are in inches (Dimensions in parenthesis are in millimeters)

Axi dyne® B3B/M3B20 Series

DIMENSIONS

B3BD/M3BD20 DUAL 180° OPTION



RODLESS

B3B/M3B20 Series

- Dual 180° carrier option dimensions

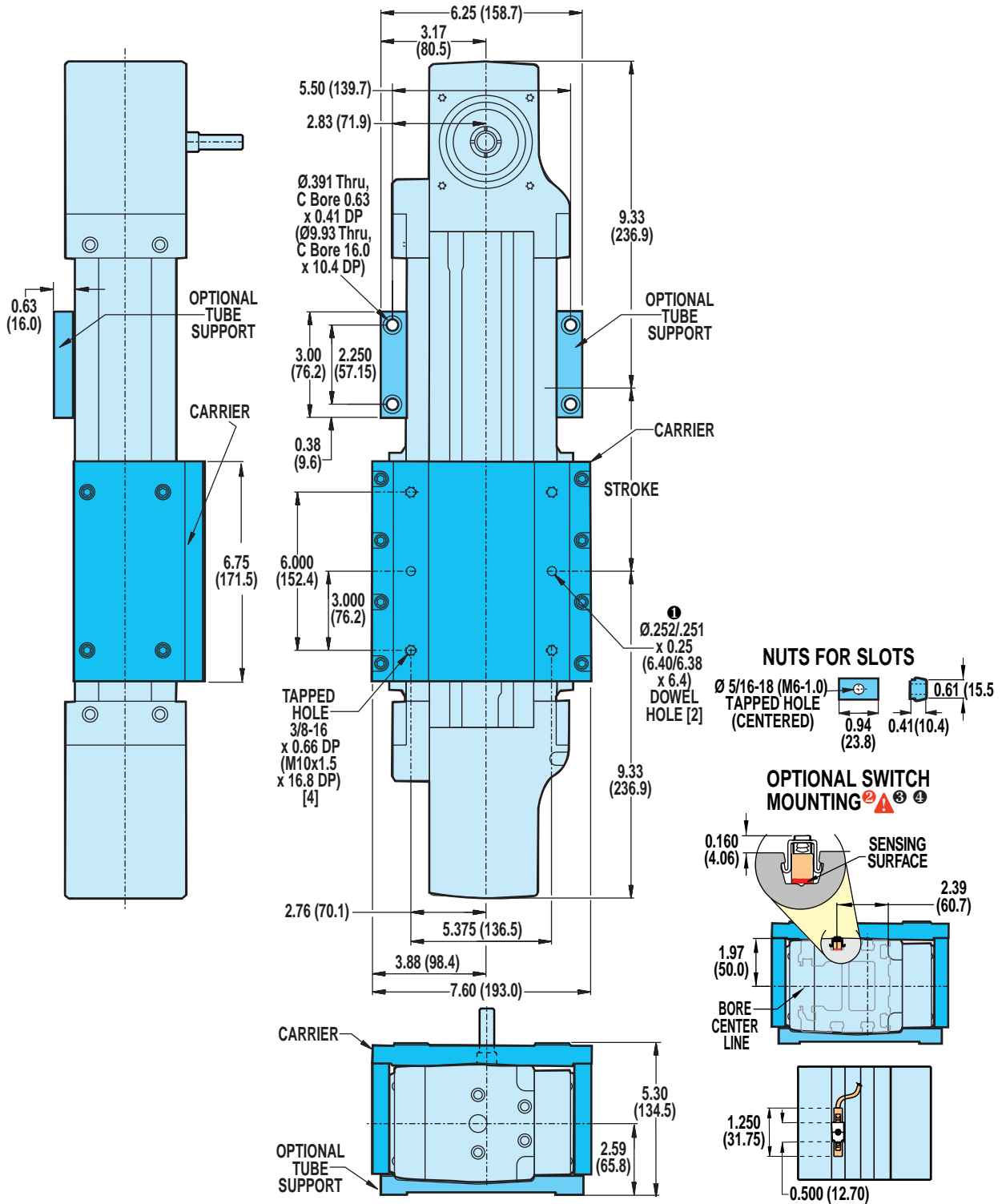

① DOWEL PINS $\pm .003$ (08mm) (M)

⚠ CAUTION: DO NOT OVERTIGHTEN SWITCH HARDWARE WHEN INSTALLING

Ⓜ NOTE: The scored face of the switch indicates the sensing surface and must face toward the magnet

Ⓝ NOTE: Some actuators require switch mounting on a specific side of the actuator. Call Tol-O-Matic 1-800-328-2174 for details

Axi-dyne® B3B/M3B20 Series

DIMENSIONS

B3BD/M3BD20 DIRECT DRIVE MOTOR MOUNTING

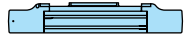
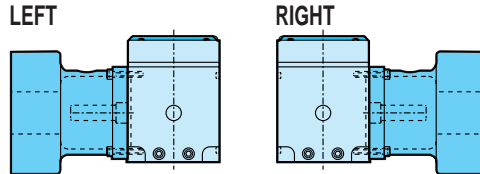
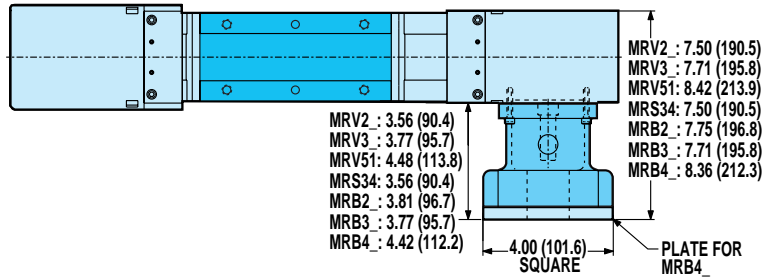

RODLESS

B3B/M3B20 Series

- Direct drive motor mounting
- Reduction drive motor mounting

B3BD/M3BD20 REDUCTION DRIVE MOTOR MOUNTING

TOP LEFT (SDTL) BOTTOM LEFT (SDBL) TOP RIGHT (SDTR) BOTTOM RIGHT (SDBR)

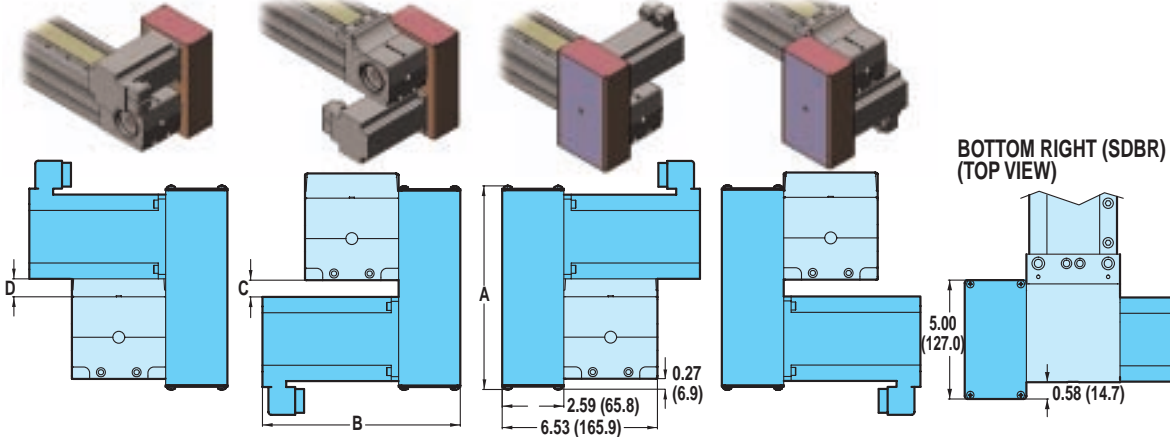

DIMENSIONS

MOTOR	A		B		C		D	
	in.	mm	in.	mm	in.	mm	in.	mm
MRV21	7.98	202.6	7.34	186.4	1.35	34.3	1.30	33.0
MRV22	7.98	202.6	8.34	211.8	1.35	34.3	1.30	33.0
MRV23	7.98	202.6	9.34	237.2	1.35	34.3	1.30	33.0
MRV24	7.98	202.6	10.34	262.6	1.35	34.3	1.30	33.0
MRV31	8.49	215.6	8.70	221.0	0.70	17.9	0.70	16.6
MRV32	8.49	215.6	9.95	252.7	0.70	17.9	0.70	16.6
MRV33	8.49	215.6	11.20	284.5	0.70	17.9	0.70	16.6
MRV51	11.66	296.1	12.55	318.8	2.35	59.6	2.35	58.3
MRS342	8.49	215.6	6.35	161.3	0.79	20.0	0.79	18.7
MRS343	8.49	215.6	7.65	194.3	0.79	20.0	0.79	18.7
MRB21	7.98	202.6	8.92	226.6	1.35	34.3	1.35	33.0
MRB31	8.49	215.6	7.66	194.6	0.84	21.4	0.84	20.2
MRB32	8.49	215.6	10.31	261.9	0.84	21.4	0.84	20.2
MRB41	8.85	224.8	13.22	335.8	0.47	12.0	0.47	10.8
MRB42	8.85	224.8	14.22	361.2	0.47	12.0	0.47	10.8

SPECIFICATIONS

MOTOR	WEIGHT OF REDUCTION DRIVE		REDUCTION INERTIA AT MOTOR SHAFT		
	lb	kg	lb-in ²	kg-m ² x 10 ⁻⁴	
BRUSHLESS	MRV21, 22, 23, 24	3.40	1.54	0.229	66.98
	MRV31, 32, 33	3.92	1.78	0.229	66.98
	MRV51	4.78	2.17	0.226	66.11
STEPPER	MRS342, 343	3.84	1.76	0.199	58.20
BRUSHED	MRB21	3.33	1.51	0.208	60.84
	MRB31, 32	3.92	1.78	0.229	66.98
	MRB41, 42	4.62	2.10	0.226	66.11

3:1 REDUCTION EFFICIENCY: 0.95

Axi dyne® B3B/M3B Belt Drives

ORDERING

BASE MODEL SPECIFICATIONS OPTIONS SPECIFICATIONS

B3BD 20 BWN15 SK56 SDTR DC18 TS2 BM2 TN16

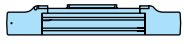

RODLESS

B3B/M3B Series

• Ordering

MODEL TYPE

B3B B3B Series English Belt Drive
B3BD B3B Series English Belt Drive with Dual 180° Carrier
M3B B3B Series Metric Belt Drive
M3BD B3B Series Metric Belt Drive with Dual 180° Carrier

TUBE BORE DIAMETER

10 1-inch (25 mm) bore
15 1 1/2-inch (40 mm) bore
20 2-inch (50 mm) bore

BELT MATERIAL AND WIDTH

BWN05 1/2-inch Neoprene/Fiberglass belt (B3B10)
BWN10 1-inch Neoprene/Fiberglass belt (B3B15)
BWN15 1.18-inch Neoprene/Fiberglass belt (B3B20)

STROKE LENGTH

SK Stroke, then enter desired stroke length in decimal inches

MOTOR MOUNTING / REDUCTIONS

(must choose one)
SDL, SDLB* Direct Drive on left
SDR, SDRB* Direct Drive on right

⚠ A motor size and code must be selected when specifying a 3:1 reduction. Reference the ordering pages in sections F, G and H for the motor types and selections.

SDTL, SDTLB* 3:1 Reduction on top left
SDTR, SDTRB* 3:1 Reduction on top right
SDBL, SDBLB* 3:1 Reduction on bottom left
SDBR, SDBRB* 3:1 Reduction on bottom right
** For Dual Stub Shaft option*

AUXILIARY CARRIER

DC_ Auxiliary Carrier, then center-to-center spacing desired in decimal inches. (Center-to-Center spacing will add to overall dead length and will not subtract from the stroke length)

SUPPORTS AND MOUNTING PLATES

(both may be selected)
TS_ Tube Supports plus quantity desired
MP_ Mounting Plates plus quantity desired

SWITCHES

RM_ Reed Switch (Form A) with 5-meter lead/QD, and quantity desired
RT_ Reed Switch (Form A) with 5-meter lead, and quantity desired
BM_ Reed Switch (Form C) with 5-meter lead/QD, and quantity desired
BT_ Reed Switch (Form C) with 5-meter lead, and quantity desired
KM_ Hall-effect Sinking Switch with 5-meter lead/QD, and quantity desired
KT_ Hall-effect Sinking Switch with 5-meter lead, and quantity desired
TM_ Hall-effect Sourcing Switch with 5-meter lead/QD, and quantity desired
TT_ Hall-effect Sourcing Switch with 5-meter lead, and quantity desired
CM_ TRIAC Switch with 5-meter lead/QD, and quantity desired
CT_ TRIAC Switch with 5-meter lead, and quantity desired

TO ORDER MOTORS/CONTROLS/INTERFACES

BRUSHLESS SERVO (SEE PAGE F-33)

MICROSTEPPING (SEE PAGE G-23)

BRUSHED DC (SEE PAGE H-26)

T-NUTS

TN_ Additional T-Nuts and quantity

⚠ Not all codes listed are compatible with all options.

Use the Tol-O-Motion™ Sizing Software to determine available options and accessories based on your application requirements.

FIELD RETROFIT KITS						
ITEM	B3B10	B3B15	B3B20	M3B10	M3B15	M3B20
Tube Supports	3410-9006	3415-90096	3420-9006	4410-9006	4415-9006	4420-9006
Tube Supports (B3BD Dual 180° models)	3410-9170	3415-9170	3420-9170	4410-9170	4415-9170	4420-9170
1/2" Mounting Plates (MRB/MRS/MRV 23-frame motors)	3410-9056	3415-9056	—	3410-9056	3415-9056	—
1/2" Mounting Plates (MRB/MRS/MRV all frame motors)	—	—	3420-9056	—	—	3420-9056
1" Mounting Plates (MRB/MRS 23-frame; MRV all frame motors)	3410-9057	—	—	3410-9057	—	—
1" Mounting Plates (MRB/MRS/MRV 34-frame motors)	—	3415-9057	—	—	3415-9057	—

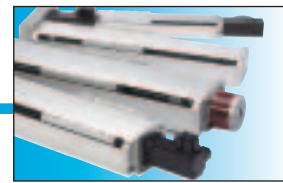

APPLICATION BENEFITS

- High precision with straightness and flatness within 0.0002 inches per inch
- Superior rigidity with high moment loads
- Lowest deflection rate of any Tol-O-Matic actuator
- Excellent repeatability
- Wide stable platform for XY applications

GUIDANCE SYSTEM



- Ground linear profiled rails and ball bearing blocks decrease deflection and provide smooth carrier/load movement

STANDARD MOUNTING



- Mounting holes are spaced the length of the actuator for ease in mounting directly to a flat surface.

ACTUATOR/MOTOR FACTORS

- Actuator's operating temperature range (40-130° F, 4-54° C) should take into consideration heat generated by the motor and drive, linear velocity and work cycle time.
- For large frame motors or small actuators, cantilevered motors need to be supported, if subjected to continuous rapid reversing duty and/or under dynamic conditions.

AVAILABLE OPTIONS



Mounting Plates: provide clearance height for motors and motor mounts when mounting on a flush surface. Recommended on all TruTrack actuators, they prevent actuator body deflections over 0.015 in (3.8mm).



Auxiliary Carrier: Increases rigidity, load-carrying capacity and bending moments



Double C-face Brake: a power-off holding brake with an output shaft.

Double C-Face brakes are used for static holding (back driving prevention) and are not designed for dynamic stopping. If your application requires stopping, please contact Tol-O-Matic.



Bellows: protects from dust and dirt environments.



Motor Mounting and Gearhead Reduction:

In-line Motor Mounting— motor is internally coupled to the actuator shaft.



Reverse-parallel Motor Mounting—These factory assembled configurations allow offset mounting of the motor to either side of, or below the actuator. Available in 1:1 or 2:1 drive ratios, they offer quiet, zero-backlash coupling of the motor to the actuator screw shaft.



Gearhead Reduction— Gearheads are available for applications requiring reduction for inertia matching or higher torque at lower speeds. High efficiency, single stage, true planetary gearheads are available in 5.5:1 and 10:1 ratios for reduction solutions with most Tol-O-Matic NEMA 23- and 34-frame motors. For gearhead specifications and dimensions, see page F-10.



Switches: Available in ac reed or dc Hall-effect. (Triac switches are not available on TruTrack actuators) See section I.



RODLESS

TKS Series

- Application benefits
- Bearing system
- Standard mounting
- Actuator/motor factors
- Available options

Axi-dyne[®] TRUTrack™ TKS Screw Drives

ACME AND BALL SCREW/NUT COMBINATIONS

TKS ENGLISH ACME AND BALL SCREW CRITICAL SPEED CAPACITIES

CRITICAL SPEED WITH ENGLISH ACME SCREW

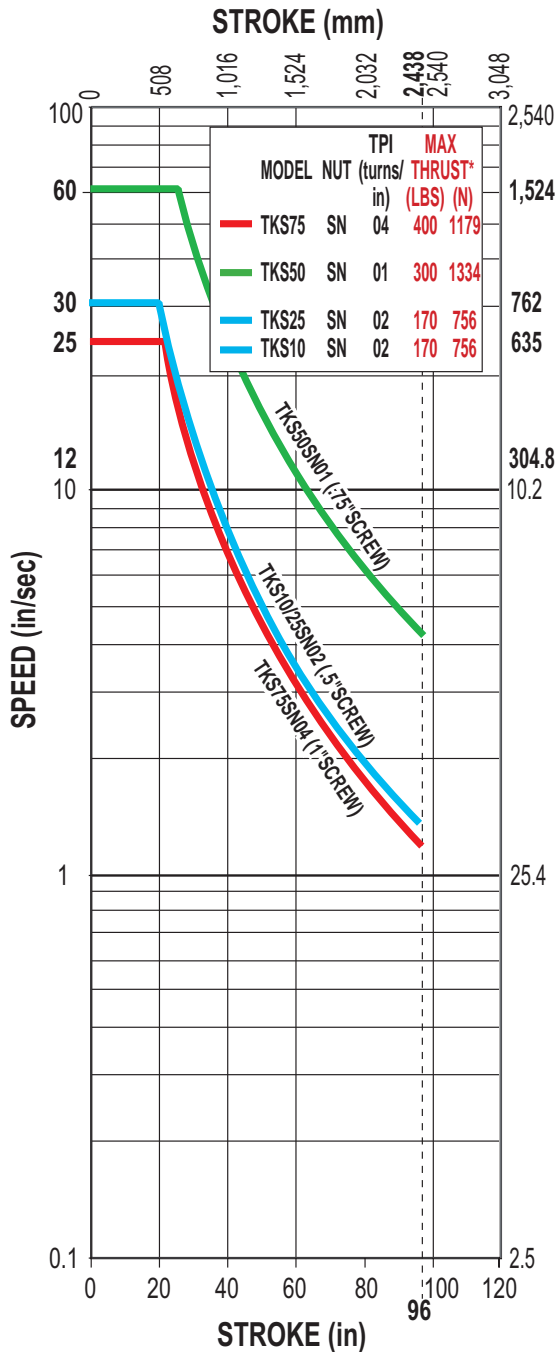

CRITICAL SPEED WITH ENGLISH BALL SCREW

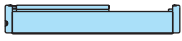
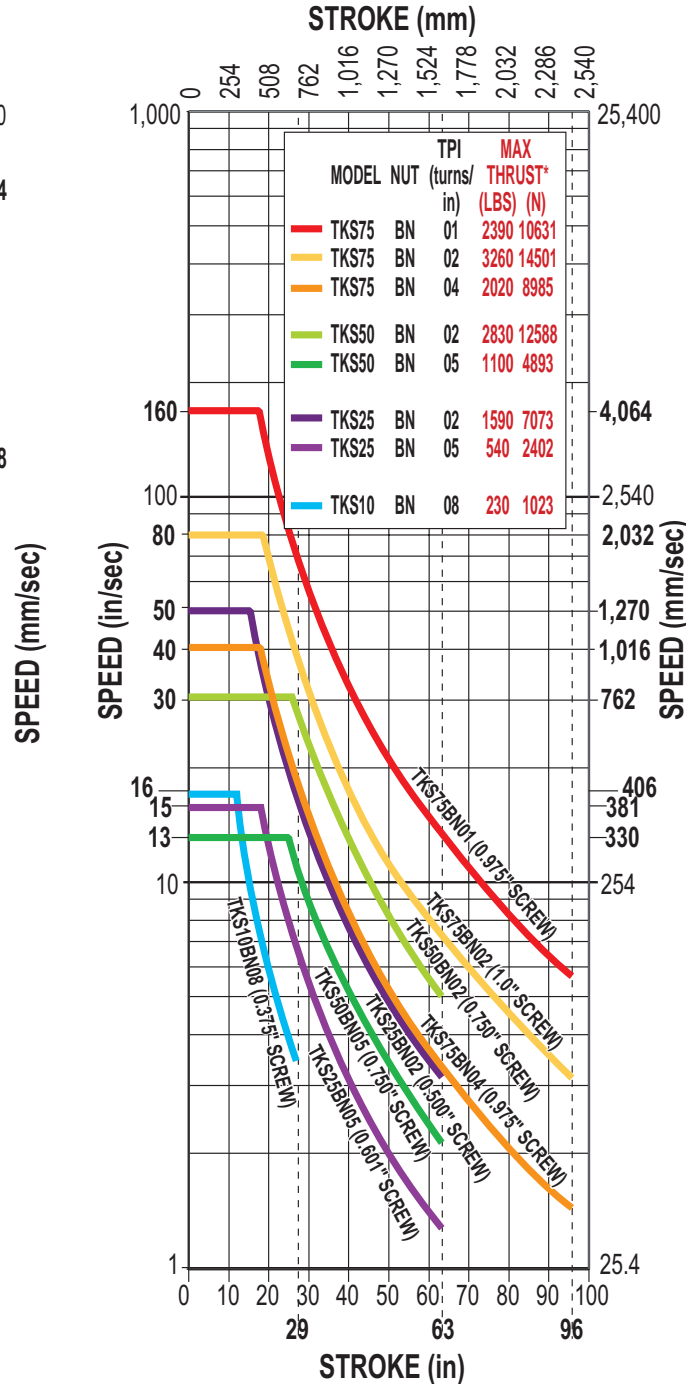

RODLESS

TKS Series

- Acme screw/nut combinations
- Acme screw critical speed
- Ball screw/nut combinations
- Ball screw critical speed



* For Acme screws, maximum thrust is the maximum continuous dynamic thrust subject to Thrust x Velocity limitation. For ball screws, maximum thrust reflects 90% reliability for 1 million linear inches of travel.

Dotted lines represent maximum stroke for screw selections.

For Acme Screw PV limits, refer to the individual charts located in the technical section for

SCREW TYPE	DESCRIPTION
SN	Solid Nut
BN	Ball Nut

Axi-dyne® TRUTrack™ TKS Screw Drives

BALL SCREW SPECIFICATIONS

TKS ENGLISH BALL SCREW LIFE CALCULATION

LIFE CAPACITIES WITH ENGLISH BALL SCREW

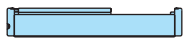
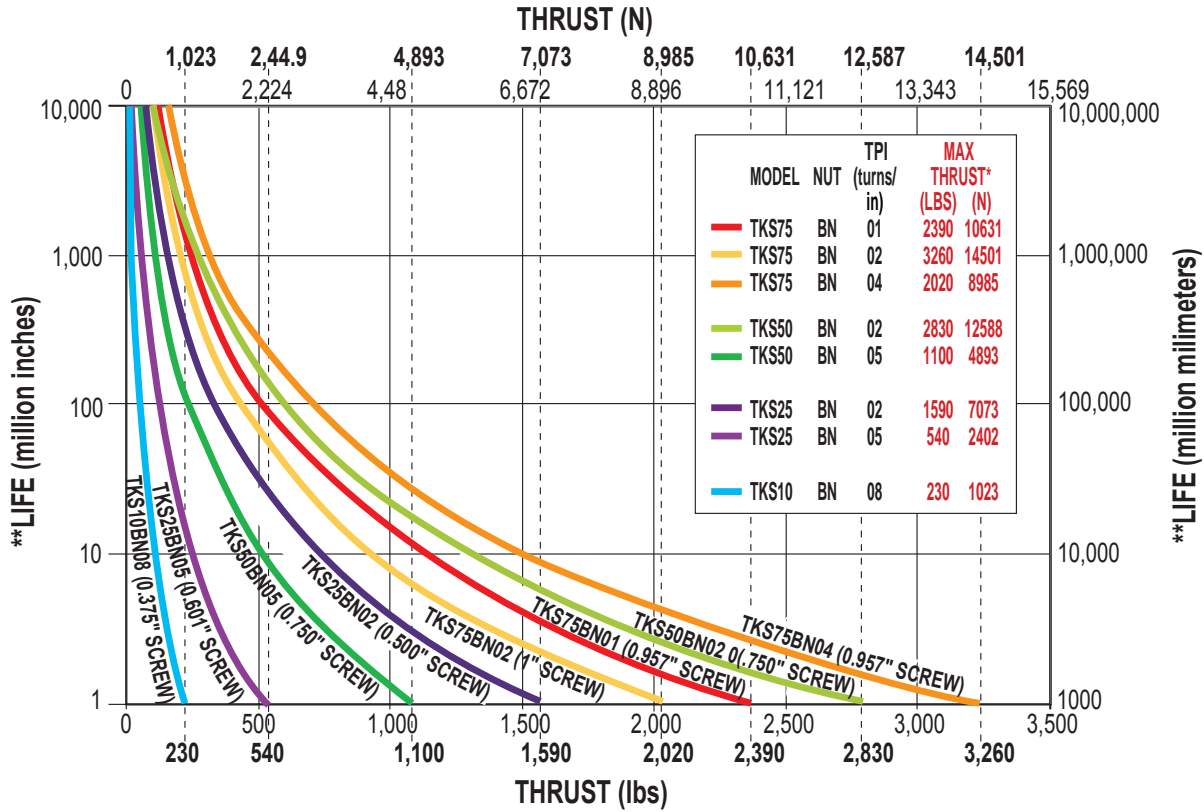

RODLESS

TKS Series
• Ball screw life capacities

SCREW TYPE **DESCRIPTION**
BN **Ball Nut**



* Maximum thrust reflects 90% reliability for 1 million linear inches of travel.

Dotted lines represent maximum thrust for screw selections.

**Life indicates theoretical maximum life of screw only, under ideal conditions and does not indicate expected life of actuator.

Axi-dyne® TRUTrack™ TKS Screw Drives

OVERALL SERIES SPECIFICATIONS

SPECIFICATIONS RELATED TO ACTUATOR SIZE AND SCREW SELECTION



RODLESS

TKS Series
• Actuator/Nut specifications

TKS ENGLISH LEAD SCREWS											
ACTUATOR SERIES	SCREW DIA. (in)	SCREW TYPE	TPI (turns/in)	LEAD ACCURACY (in/ft)	BACKLASH (in)	MAXIMUM THRUST* (lb)	MAXIMUM STROKE (in)	INERTIA (lb-in ²)			BREAKAWAY TORQUE (lb-in)
								BASE ACTUATOR		PER/in OF STROKE	
								In Line	Rev. Parallel		
TKS10	0.500	SN	02	0.003	0.007	170	96	0.0126	0.0159	0.0017	0.938
	0.375	BN	08	0.004	0.002	230	29	0.0029	0.0038	0.0005	0.813
TKS25	0.500	SN	02	0.003	0.007	170	96	0.0263	0.0291	0.0017	1.750
	0.500	BN	02	0.004	0.002	1590	63	0.0263	0.0291	0.0017	1.438
TKS50	0.625	BN	05	0.004	0.002	540	63	0.0311	0.0380	0.0042	1.063
	0.750	SN	01	0.003	0.007	300	96	0.1472	0.1577	0.0087	3.750
	0.750	BN	02	0.004	0.002	2830	63	0.0867	0.0972	0.0087	1.875
TKS75	0.750	BN	05	0.004	0.002	1100	63	0.0698	0.0803	0.0087	1.500
	1.00	SN	04	0.003	0.007	400	96	0.2196	0.2737	0.0275	2.813
	1.00	BN	01	0.004	0.002	2390	96	0.3037	0.3578	0.0275	3.438
	1.00	BN	02	0.004	0.002	3260	96	0.2364	0.2905	0.0275	2.813
	1.00	BN	04	0.004	0.002	2020	96	0.2196	0.2737	0.0275	2.500

METRIC CONVERSIONS											
ACTUATOR SERIES	SCREW Ø (in)	SCREW TYPE	TPI (turns/in)	LEAD ACCURACY (mm/300)	BACKLASH (mm)	MAXIMUM THRUST* (N)	MAXIMUM STROKE (mm)	INERTIA (kg-m ² x 10 ⁻⁴)			BREAKAWAY TORQUE (N-m)
								BASE ACTUATOR		PER/mm OF STROKE	
								In Line	Rev. Parallel		
TKS10	0.50	SN	02	0.0762	0.1778	756	2438	3.69	4.65	0.50	0.11
	0.375	BN	08	0.1016	0.0508	1023	737	0.85	1.11	0.15	0.09
TKS25	0.50	SN	02	0.0762	0.1778	756	2438	7.69	8.51	0.49	0.20
	0.50	BN	02	0.1016	0.0508	7073	1600	7.69	8.51	0.49	0.16
	0.625	BN	05	0.1016	0.0508	2402	1600	9.10	11.12	2.17	0.12
TKS50	0.75	SN	01	0.0762	0.1778	1334	2438	43.06	46.13	2.54	0.42
	0.75	BN	02	0.1016	0.0508	12588	1600	25.36	28.43	2.54	0.21
	0.75	BN	05	0.1016	0.0508	4893	1600	20.42	23.49	2.54	0.17
TKS75	1.00	SN	04	0.0762	0.1778	1779	2438	64.23	80.06	8.04	0.31
	1.00	BN	01	0.1016	0.0508	10631	2438	88.83	104.66	8.04	0.39
	1.00	BN	02	0.1016	0.0508	14234	2438	69.15	84.97	8.04	0.31
	1.00	BN	04	0.1016	0.0508	8985	2438	64.23	80.06	8.04	0.28

⚠ Contact the factory for higher accuracy and lower backlash options.

SCREW TYPE	DESCRIPTION
SN	Solid Nut
BN	Ball Nut

* For Acme screws, maximum thrust is the maximum continuous dynamic thrust subject to Thrust x Velocity limitation. For ball screws, maximum thrust reflects 90% reliability for 1 million linear inches of travel.

OVERALL SERIES SPECIFICATIONS

GENERAL ACTUATOR SPECIFICATIONS

SPECIFICATIONS	TKS ENGLISH ACTUATORS				METRIC CONVERSIONS			
	TKS10	TKS25	TKS50	TKS75	TKS10	TKS25	TKS50	TKS75
Carrier weight (lbs : kg)	0.56	2.31	3.18	3.54	0.25	1.05	1.44	1.61
Base weight in-line model (including carrier without motor) (lbs : kg)	3.22	9.46	14.56	17.95	1.46	4.29	6.60	8.14
Weight per/in (mm) of stroke (lbs : kg)	0.229	0.527	0.728	0.932	0.10	0.24	0.33	0.42
Straightness (YX Plane) (unconstrained ¹) (in/in : mm/mm)	0.0004	0.0004	0.0004	0.0004	0.0004	0.0004	0.0004	0.0004
Straightness (YX Plane) (constrained ²) (in/in : mm/mm)	0.0002	0.0002	0.0002	0.0002	0.0002	0.0002	0.0002	0.0002
Flatness (ZX Plane) (unconstrained ¹) (in/in : mm/mm)	0.0008	0.0008	0.0008	0.0008	0.0008	0.0008	0.0008	0.0008
Flatness (ZX Plane) (constrained ²) (in/in : mm/mm)	0.0002	0.0002	0.0002	0.0002	0.0002	0.0002	0.0002	0.0002
Screw uni-directional repeatability ³ (in : mm)	±0.0004	±0.0004	±0.0004	±0.0004	±0.010	±0.010	±0.010	±0.010
Temperature Range ⁴ (F° : C°)	40-130	40-130	40-130	40-130	4-54	4-54	4-54	4-54



¹ Listed values are intended for reference purposes only, and not as an engineering standard of absolute tolerance for a given actuator. Values were derived from testing of characteristic samples of appropriate products, and indicate an expected range of deviation from a theoretical straight line in the indicated plane of carrier motion. Appropriate installation is the single most important factor in reducing such deviation, so good engineering practices such as measurement, mapping, etc. must be employed in applications with stringent straightness/flatness requirements. For more information on how these values were obtained, please read the white paper on this subject available at www.tolomatic.com.

² Actuator mounted on a flat surface and fully restrained. (See dimensional drawings on pages C-60, C-66, C-72 and C-78)

³ Ball screw; not including backlash

⁴ Heat generated by the motor and drive should be taken into consideration as well as linear velocity and work cycle time. For applications that require operation outside of the recommended temperature range, contact the factory.

LARGE FRAME MOTORS AND SMALLER SIZE ACTUATORS: Cantilevered motors need to be supported, if subjected to continuous rapid reversing duty and/or under dynamic conditions.



RODLESS

TKS Series

- General actuator specifications
- Friction force
- Lubrication
- Mounting recommendations

FRICITION FORCE

$$lbf = 0.0003 \times \text{LOAD (lb)} + 3.96$$

$$N = 0.003 \times \text{LOAD (kg)} + 17.6$$

LUBRICATION

Proper and adequate lubrication is essential for normal operation of TruTrack actuators. Poor lubrication will cause quicker wear and decrease service life of the actuator. For general use, lubrication should be performed at intervals of 4,000,000 linear inches of travel (100 km) or once every year, whichever occurs first. However, the operating conditions of certain applications may require more frequent lubrication. Please consult Tol-O-Matic for recommendations.

Recommended greases:

- Multi-purpose grease based on refined mineral oil containing lithium thickening agent (excellent at high pressures, excellent viscosity stability).
- Grease based on a high-grade synthetic oil containing a urea thickening agent (long life, wide temperature range).

MOUNTING RECOMMENDATIONS

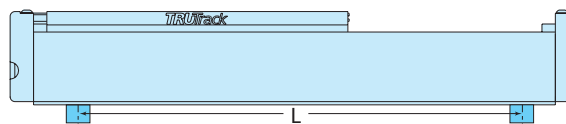
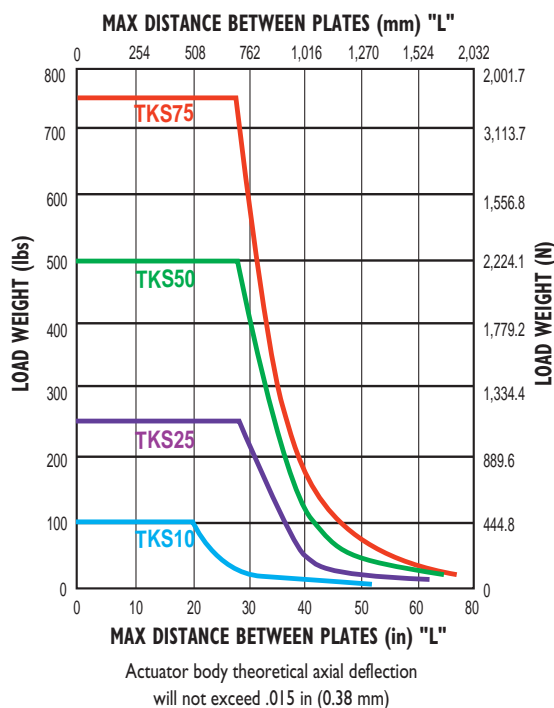

Axi-dyne[®] TRUTrack™ TKS Screw Drives

OVERALL SERIES SPECIFICATIONS

BENDING MOMENTS AND LOADS



RODLESS

TKS Series

• Bending moments and loads

STANDARD CARRIER		MAXIMUM BENDING MOMENTS AND LOADS*				ENGLISH		METRIC CONVERSIONS		
		TKS10	TKS25	TKS50	TKS75	TKS10	TKS25	TKS50	TKS75	
	Maximum Dynamic Bending Moments									
	Mx (Roll)	(lb-in : N-m)	85	721	971	1151	9.6	81.5	109.7	130.0
	My (Pitch)	(lb-in : N-m)	234	1014	1442	1477	26.4	114.6	162.9	166.9
	Mz (Yaw)	(lb-in : N-m)	234	915	1301	1332	26.4	103.4	147.0	150.5
	Maximum Dynamic Loads									
	Fy (Radial Load)	(lb : N)	100	250	500	750	445	1113	2225	3338
	Fz (Lateral Load)	(lb : N)	100	250	500	750	445	1113	2225	2225
	Fzr (Reverse Lateral Load)	(lb : N)	100	250	500	750	445	1113	2225	2225
	Maximum Static Bending Moments									
	Mx (Roll)	(lb-in : N-m)	170	1251	1685	1997	19.2	141.3	190.3	225.6
	My (Pitch)	(lb-in : N-m)	468	1759	2502	2563	52.9	198.8	282.7	289.5
	Mz (Yaw)	(lb-in : N-m)	468	1588	2257	2311	52.9	179.4	255.0	261.1
Maximum Static Loads										
Fy (Radial Load)	(lb : N)	200	434	868	1301	890	1931	3863	5789	
Fz (Lateral Load)	(lb : N)	200	434	868	868	890	1931	3863	3863	
Fzr (Reverse Lateral Load)	(lb : N)	200	434	868	868	890	1931	3863	3863	
AUXILIARY CARRIER: Increases rigidity, load-carrying capacity and moments		TKS10	TKS25	TKS50	TKS75	TKS10	TKS25	TKS50	TKS75	
	Maximum Dynamic Bending Moments									
	Mx (Roll)	** (lb-in : N-m)	170	1442	1942	2302	19.2	162.9	219.4	260.1
	My (Pitch)	** (lb-in : N-m)	563	1733	3810	3875	63.6	195.7	430.5	437.8
	Mz (Yaw)	** (lb-in : N-m)	563	1733	3810	3875	63.6	195.7	430.5	437.8
	Maximum Dynamic Loads									
	Fy (Radial Load)	(lb : N)	200	500	1000	1500	890	2225	4450	6675
	Fz (Lateral Load)	(lb : N)	200	500	1000	1500	890	2225	4450	4450
	Fzr (Reverse Lateral Load)	(lb : N)	200	500	1000	1500	890	2225	4450	4450
	Maximum Static Bending Moments									
	Mx (Roll)	** (lb-in : N-m)	340	2502	3369	3994	38	283	381	451
	My (Pitch)	** (lb-in : N-m)	1126	3006	6610	6723	127	340	747	760
	Mz (Yaw)	** (lb-in : N-m)	1126	3006	6610	6723	127	340	747	760
Maximum Static Loads										
Fy (Radial Load)	(lb : N)	400	868	1735	2603	1780	3863	7721	11583	
Fz (Lateral Load)	(lb : N)	400	868	1735	1735	1780	3863	7721	7721	
Fzr (Reverse Lateral Load)	(lb : N)	400	868	1735	1735	1780	3863	7721	7721	
Minimum Dimension 'D'		(in : mm)	5.63	6.93	7.63	7.75	142.9	176.0	193.8	196.9



* Bending moments are based on 200,000,000 (5,000 KM) linear inches of carrier travel.

Breakaway torque will increase when using the Auxiliary carrier option. When ordering, determine your working stroke and enter this value into the configuration string. Overall actuator length will automatically be calculated.

Deflection Considerations: In applications where substantial Mx or My moments come into play, deflection of the cylinder tube, carrier and supports must be considered. The deflection factors shown in the Load Deflection charts, are based on cylinder mounted with tube supports at minimum recommended spacing. If more rigidity is desired, refer to the Auxiliary or Dual Carrier options.

** Loads shown in table are at minimum "D" dimension, for ratings with longer "D" dimension see graph on page C-57.

Axi-dyne[®] TRUtrack™ TKS Screw Drives

OVERALL SERIES SPECIFICATIONS

LOAD DEFLECTION

X-AXIS DEFLECTION

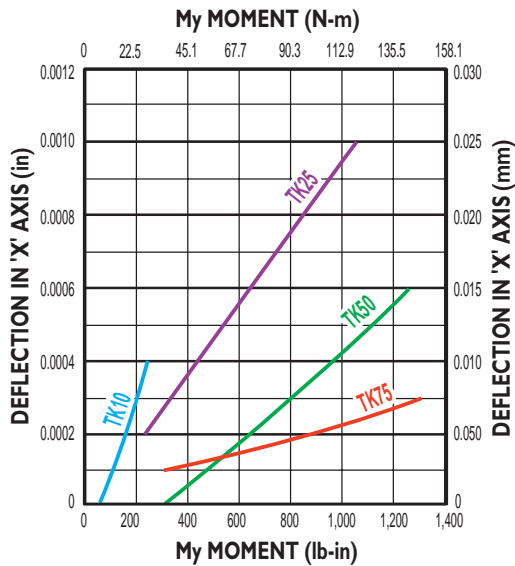
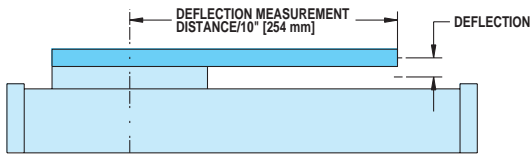

Y-AXIS DEFLECTION

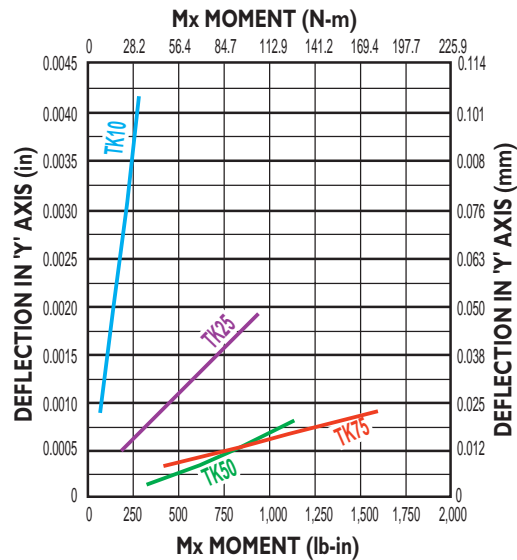
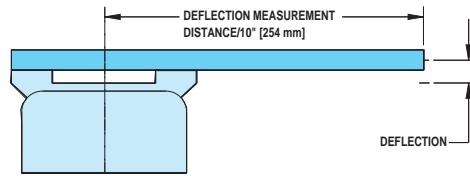

RODLESS

- TKS Series
- Load deflection
- Auxiliary Carrier

AUXILIARY CARRIER: BENDING MOMENT AT 'D' DISTANCE

DYNAMIC BENDING MOMENT

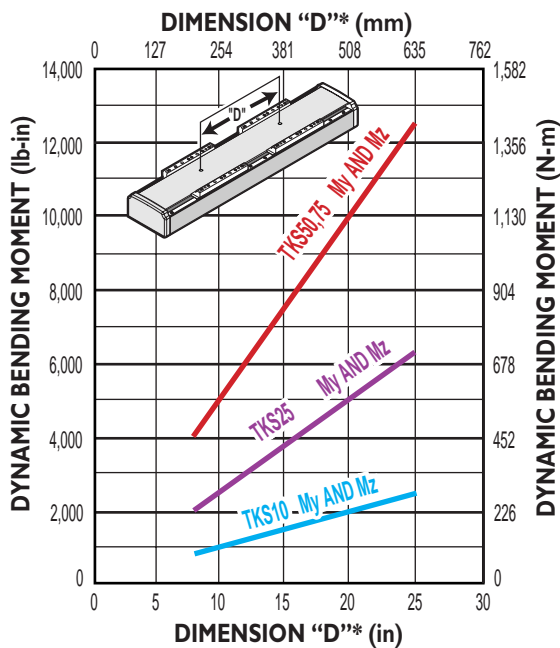

STATIC BENDING MOMENT

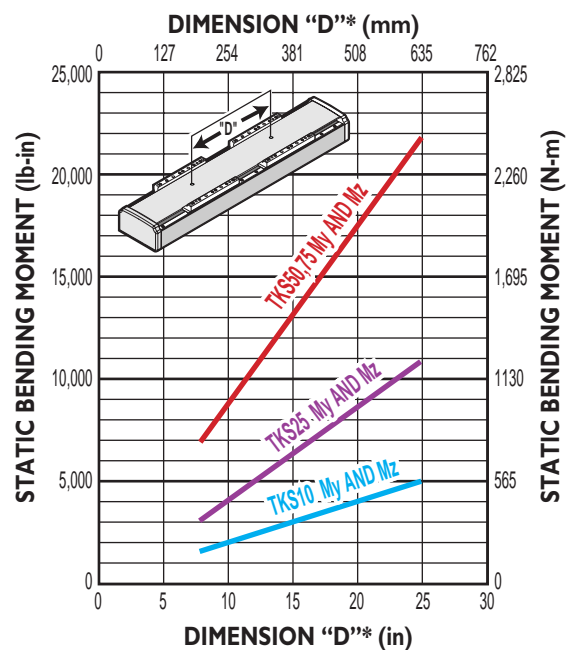

- Rates shown on charts were calculated with these assumptions:
- 1.) Coupling between carriers is rigid.
 - 2.) Load is equally distributed between carriers.
 - 3.) Coupling device applies no misalignment loads to carriers.

* Customer must specify Dimension "D" (Distance between carrier center lines) in configuration string.

Axi *dyne*® TRUTrack™ TKS Screw Drives

OVERALL SERIES SPECIFICATIONS

BELLOWS STROKE REQUIREMENTS

STANDARD ACTUATOR

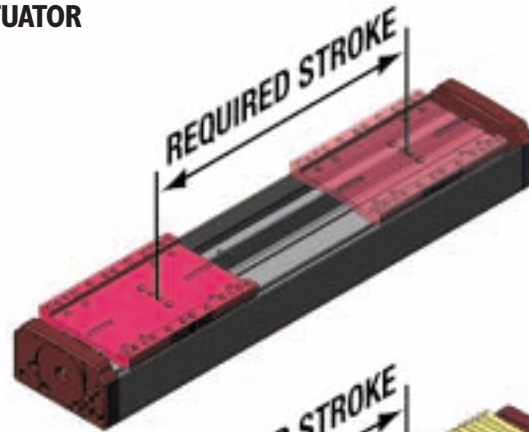

STANDARD ACTUATOR WITH BELLOWS COVER

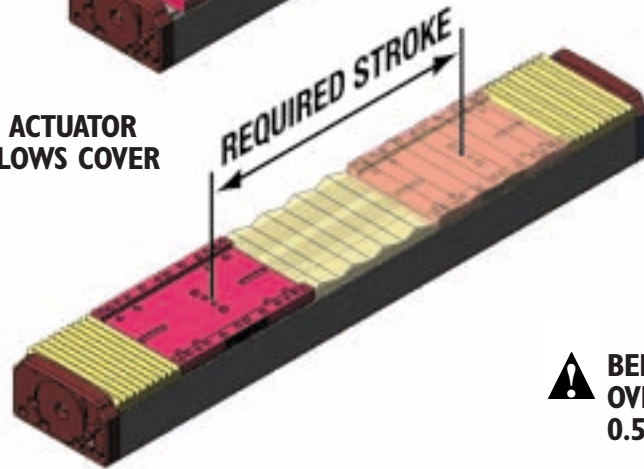

⚠ BELLOWS COVER OPTION INCREASES OVERALL ACTUATOR LENGTH BY 0.508 x STROKE



RODLESS

TKS Series
• Bellows stroke requirements

MAXIMUM AVAILABLE STROKE FOR BELLOWS OPTION

WITH BALL NUT

WITH SOLID NUT

TKS10	24 inches (610 mm)	64 inches (1626 mm)
TKS25	44 inches (1118 mm)	64 inches (1626 mm)
TKS50	56 inches (1422 mm)	64 inches (1626 mm)
TKS75	64 inches (1626 mm)	64 inches (1626 mm)

Axi-dyne[®] TRUTrack™ TKS10 Series

SCREW SPECIFICATIONS



TKS10 ACME SCREW CRITICAL SPEED AND PV LIMITS

CRITICAL SPEED WITH 0.500" 2TPI ENGLISH ACME SCREW

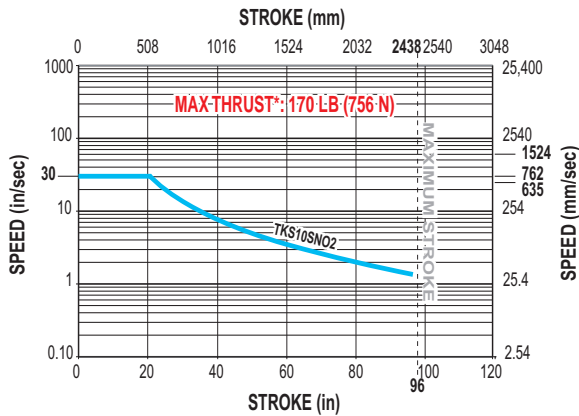

PV LIMITS: 0.500" 2 TPI ENGLISH ACME SCREW

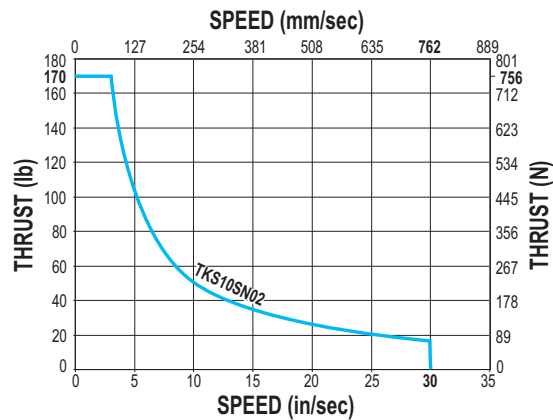

RODLESS

TKS10 Series

- Acme screw critical speed capacities and PV limits
- Ball screw critical speed capacities and life calculations

SN = Solid Nut



* Maximum thrust is the maximum continuous dynamic thrust subject to Thrust x Velocity limitation.

PV LIMITS: Any material which carries a sliding load is limited by heat buildup. The factors that affect heat generation rate in an application are the pressure on the nut in pounds per square inch and the surface velocity in feet per minute. The product of these factors provides a measure of the severity of an application.

$$P = \frac{\text{Thrust}}{\text{Max. Thrust Rating}} \times V = \frac{\text{Speed}}{\text{Max. Speed Rating}} \leq 0.1$$

TKS10 BALL SCREW CRITICAL SPEED AND LIFE CALCULATIONS

CRITICAL SPEED WITH 0.375" 8TPI ENGLISH BALL SCREW

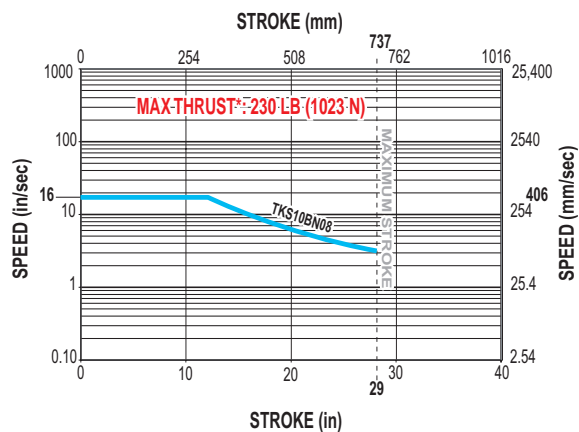

LIFE CALCULATION: 0.375" 8TPI ENGLISH BALL SCREW

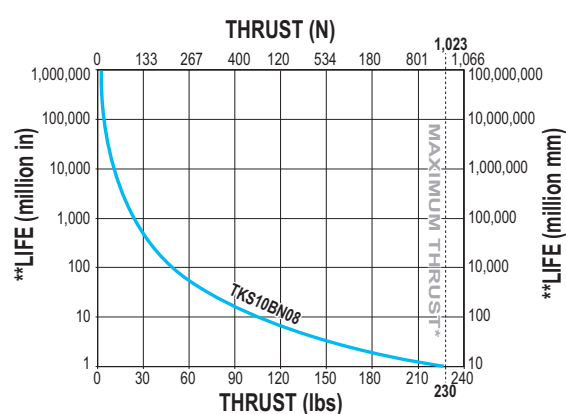

BN = Ball Nut



* Maximum thrust reflects 90% reliability for 1 million linear inches of travel.

**Life indicates theoretical maximum life of screw only, under ideal conditions and does not indicate expected life of actuator.

Axi dyne® TRUTrack™ TKS10 Series

DIMENSIONS

TKS10 ACTUATOR AND OPTIONS

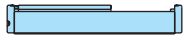

RODLESS

TKS10 Series

• Actuator and options dimensions

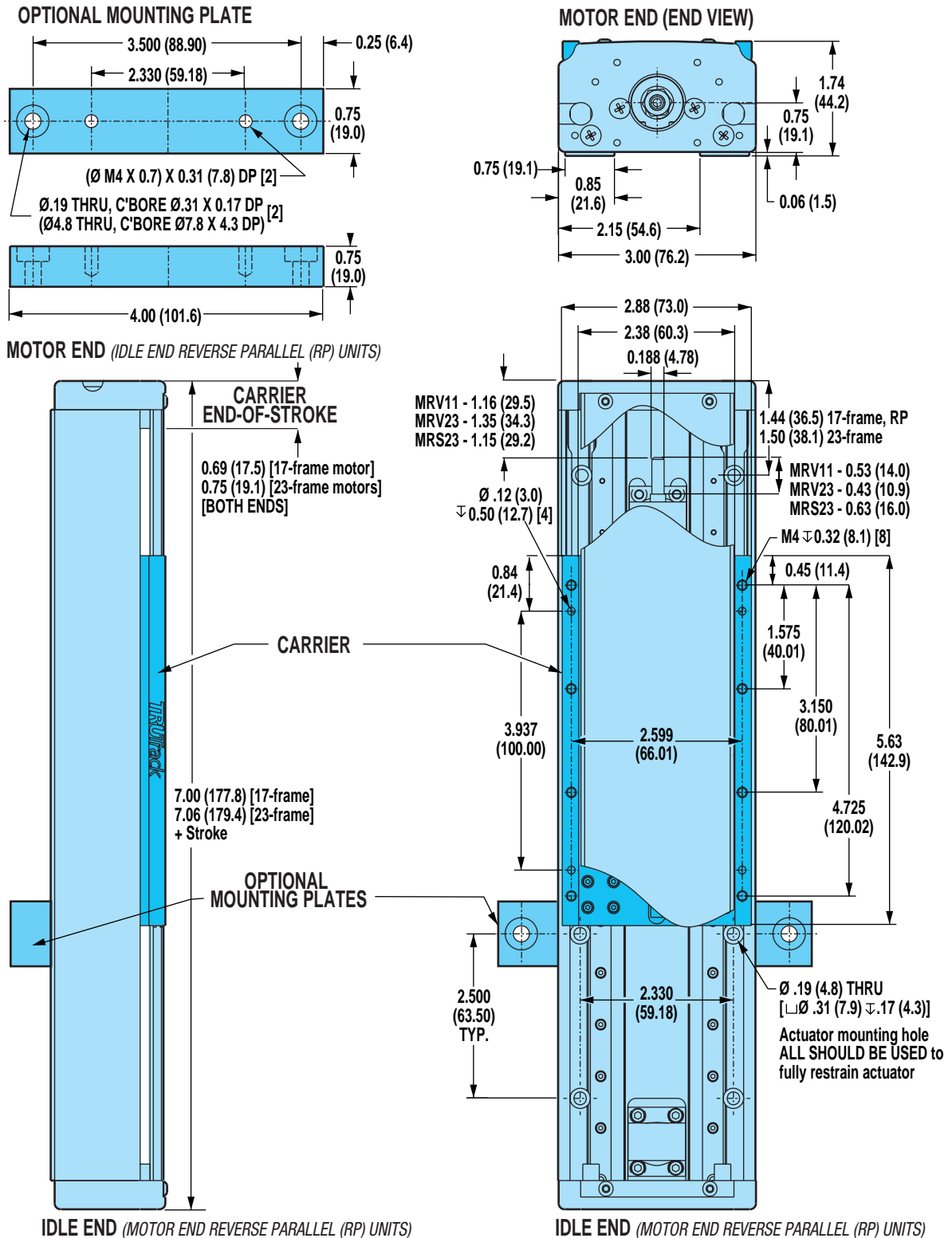

WHEN SPECIFYING THE XY/XJ SHAFT OPTION: IF A TOL-O-MATIC MOTOR IS NOT SPECIFIED IN THE CONFIGURATION STRING, CUSTOMER'S MOTOR MUST CONFORM TO THE SHAFT DIMENSIONS SHOWN FOR MOUNTING COMPATIBILITY. PLEASE SPECIFY YOUR MOTOR TYPE AND FRAME SIZE WHEN ORDERING.

Unless otherwise noted, all dimensions shown are in inches (Dimensions in parenthesis are in millimeters)

DIMENSIONS

TKS10: DOUBLE C-FACE BRAKE OPTION

BRAKE FOR 23-FRAME MOTOR

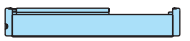
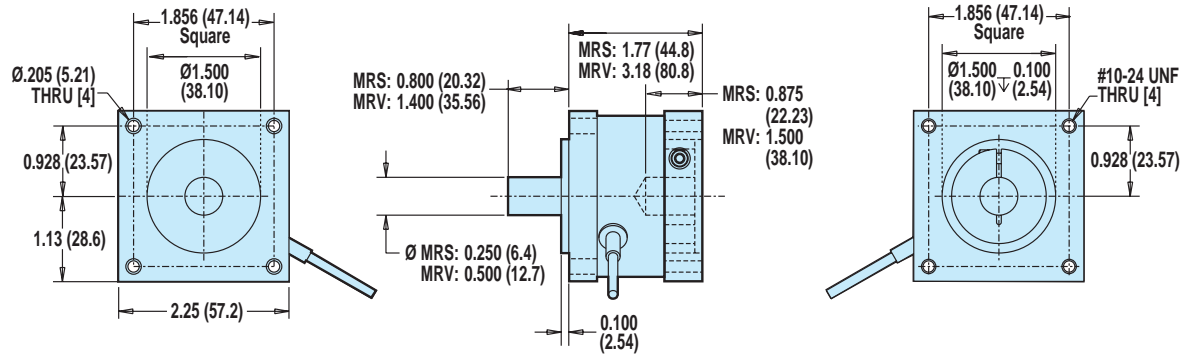

RODLESS

TKS10 Series
• Double C-face Brake dimensions

MOTOR TYPE	MOTOR/ FRAME	BRAKE PART NO.	STATIC TORQUE		REFLECTED INERTIA		WEIGHT		VOLTAGE	CURRENT	RESISTANCE	CABLE LENGTH	
			lb-in	N-m	lb-in ²	kg-m ² x10 ⁻⁴	lb	kg				in	mm
BRUSHLESS	MRV 23	3600-6286	10	1.130	0.0125	3.66	10.6	0.48	24	0.182	132.0	16.75	425
STEPPER	MRS 23	3600-6285	10	1.130	0.0125	3.66	10.6	0.48	24	0.182	132.0	16.75	425

MAXIMUM BRAKE HOLDING LOADS						
LEADSCREW/NUT REDUCTION	23-FRAME BRAKE					
	INLINE		5.5:1 GEARHEAD		10:1 GEARHEAD	
	lb	kg	lb	kg	lb	kg
TKS10 with SN02	180	81.6	180	81.6	180	81.6
TKS10 with BN08	559	253.5	1874	850.0	1874	850.0



Double C-face brakes are used for static holding (back driving prevention) and are not designed for dynamic stopping. Please contact Tol-O-Matic if your application requires dynamic stopping. This brake can be used with other Tol-O-Matic systems. Consult the factory for availability.

Axi dyne® TRUTrack™ TKS10 Series

DIMENSIONS

TKS10: IN-LINE MOUNT FOR 17-FRAME BRUSHLESS (MRV) MOTORS



RODLESS

TKS10 Series

- In-line motor mount dimensions
- Shaft xy/xj option

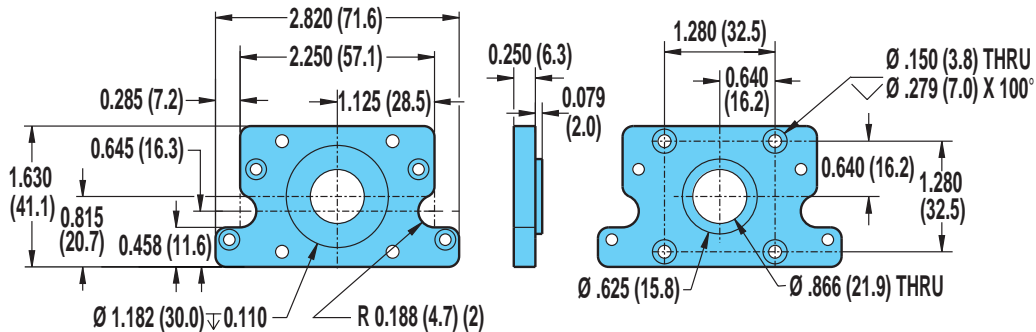

! 17-frame MRV motors cannot be mounted directly to the actuator head and require the use of the motor adapter plate shown. Gearhead option is not available with 17-frame motors.

TKS10: IN-LINE MOUNT FOR 23-FRAME BRUSHLESS (MRV) MOTORS, OR GEARHEAD

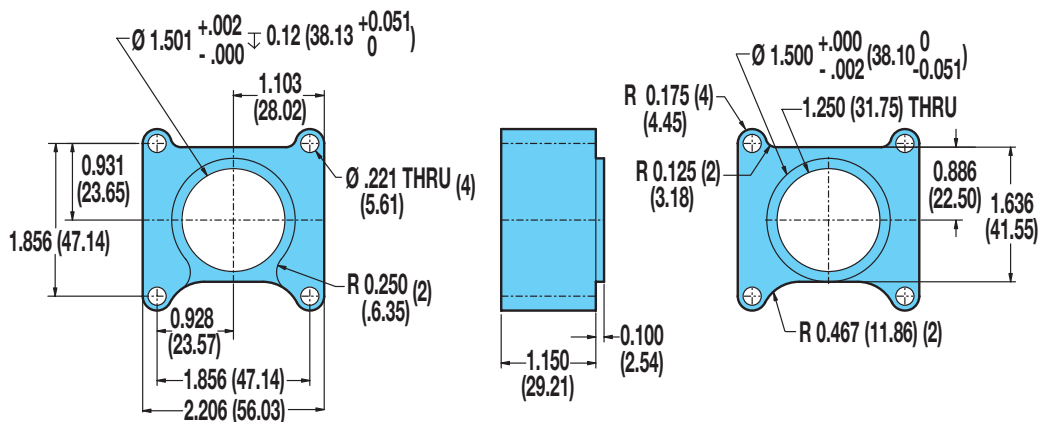

! 23-frame brushless MRV motors cannot be mounted directly to the actuator head and requires the use of the motor adapter plate shown. 23-frame stepper MRS motors are mounted directly to the actuator head and no motor adapter plates are required.



INTERCHANGING MOTORS: Leadscrews on TruTrack actuators are specific to the motor type specified. Motor mounting plates do not provide for interchanging servo or stepper motors.

For a complete part listing of screw-drive motor and gearhead mounting kits referencing actuator/motor/coupler compatibilities, refer to document 3600-4631 available on the Literature/Part Sheet/Axidyne section of our web site at: www.tolomatic.com.

For gearhead dimensions and specifications, refer to page F-10.

DIMENSIONS

TKS10: REVERSE PARALLEL MOUNTING

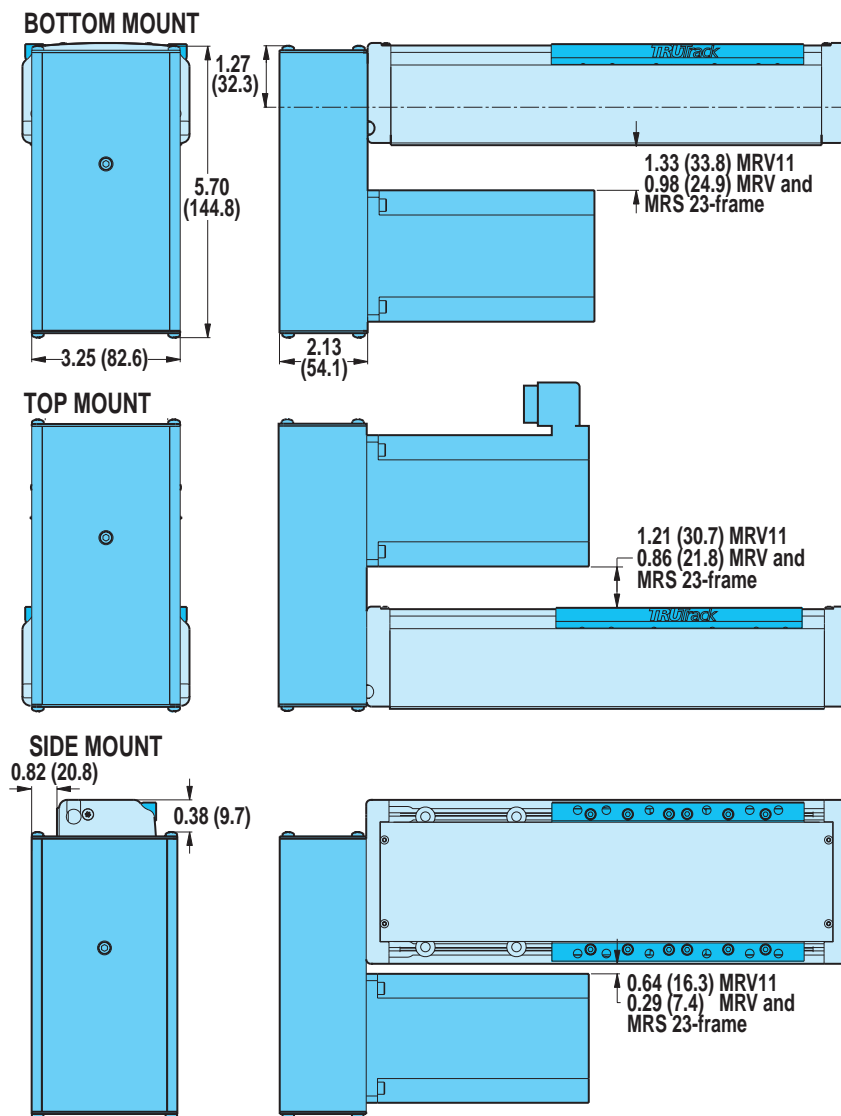

RODLESS

TKS10 Series

- Reverse parallel mounting

SPECIFICATIONS

	MOTOR	WEIGHT OF REDUCTION DRIVE				REDUCTION INERTIA AT MOTOR SHAFT			
		1:1		2:1		1:1 RATIO		2:1 RATIO	
		lbs	kg	lbs	kg	lb-in ²	kg-m ² x 10 ⁻⁴	lb-in ²	kg-m ² x 10 ⁻⁴
BRUSHLESS	MRV11	1.80	0.82	1.80	0.82	0.026	7.605	0.056	16+.453
	MRV21, 22, 23, 24	1.80	0.82	1.80	0.82	0.039	11.408	0.058	16.819
STEPPER	MRS231, 232	1.66	0.75	1.66	0.75	0.024	7.020	0.054	15.8681

REDUCTION EFFICIENCY: 0.95



Axi dyne® TRUTrack™ TKS25 Series ACME SCREW SPECIFICATIONS

TKS25 ACME SCREW CRITICAL SPEED AND PV LIMITS

CRITICAL SPEED WITH 0.500" ENGLISH ACME SCREW

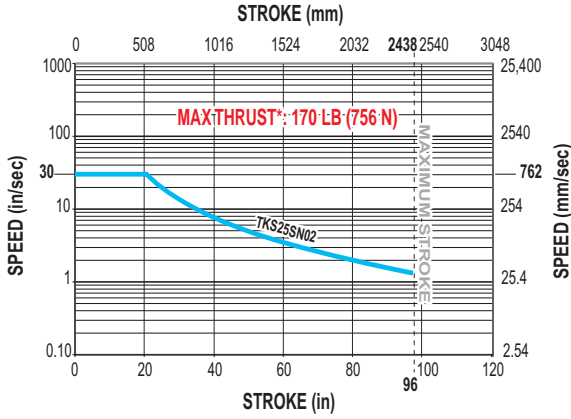

PV LIMITS: 1/2" 2 TPI ENGLISH ACME SCREW

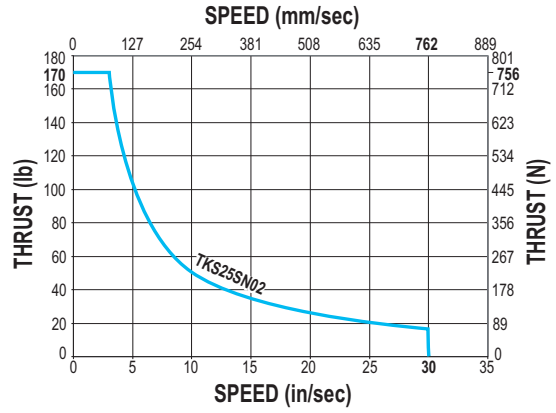

RODLESS

TKS25 Series

- Acme screw critical speed capacities and PV limits

SN = Solid Nut



* *Maximum thrust is the maximum continuous dynamic thrust subject to Thrust x Velocity limitation.*

PV LIMITS: Any material which carries a sliding load is limited by heat buildup. The factors that affect heat generation rate in an application are the pressure on the nut in pounds per square inch and the surface velocity in feet per minute. The product of these factors provides a measure of the severity of an application.

$$P = \frac{\text{Thrust}}{\text{Max. Thrust Rating}} \times V = \frac{\text{Speed}}{\text{Max. Speed Rating}} \leq 0.1$$

Axi-dyne® TRUTrack™ TKS25 Series

BALL SCREW SPECIFICATIONS

TKS25 BALL SCREW CRITICAL SPEED AND LIFE CALCULATIONS

CRITICAL SPEED WITH 0.500" 2TPI ENGLISH BALL SCREW

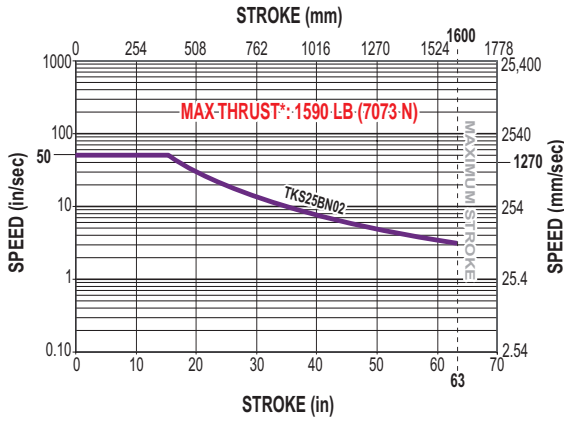

LIFE CALCULATION: 0.500" 2TPI ENGLISH BALL SCREW

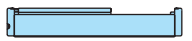
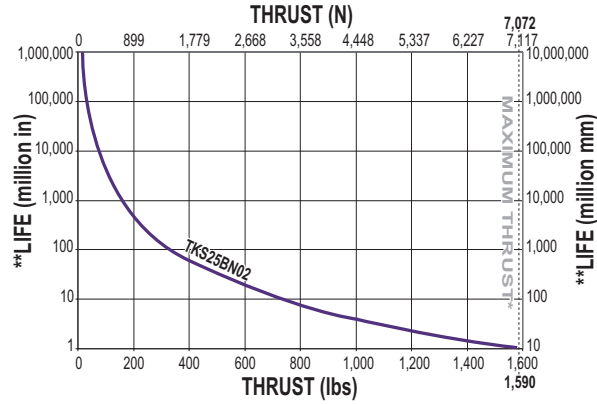

RODLESS

TKS25 Series

- Ball screw critical speed capacities and life calculations

CRITICAL SPEED WITH 0.601" 5TPI ENGLISH BALL SCREW

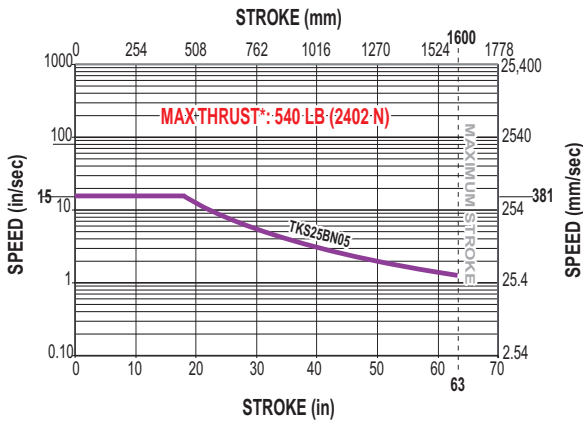

LIFE CALCULATION: 0.601" 5TPI ENGLISH BALL SCREW

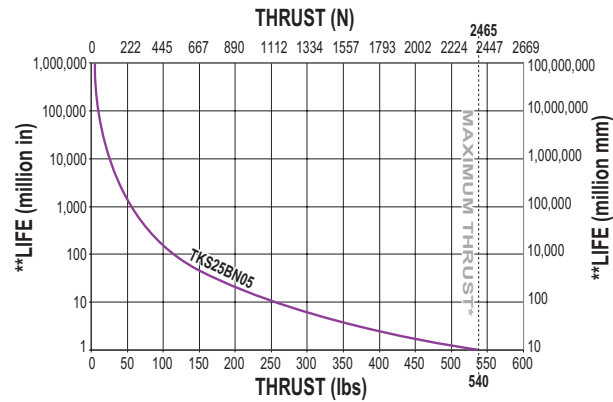

BN = Ball Nut



* Maximum thrust reflects 90% reliability for 1 million linear inches of travel.

**Life indicates theoretical maximum life of screw only, under ideal conditions and does not indicate expected life of actuator.

Axi-dyne[®] TRUTrack™ TKS25 Series

DIMENSIONS

TKS25 ACTUATOR AND OPTIONS

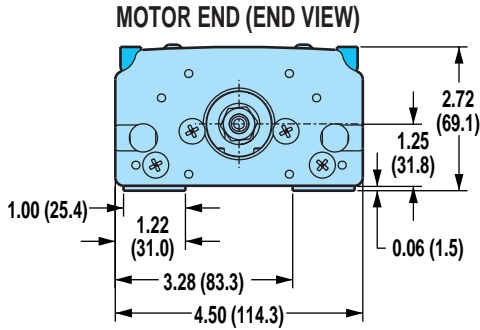
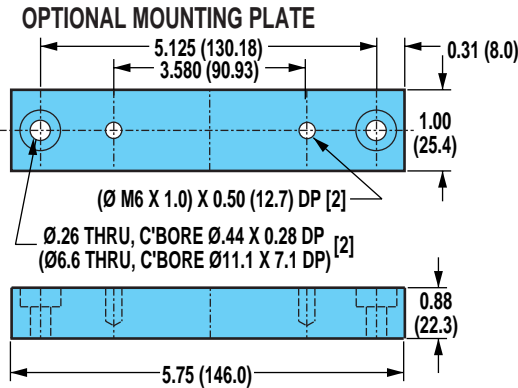

RODLESS

TKS25 Series

• Actuator and options dimensions

MOTOR END (IDLE END REVERSE PARALLEL (RP) UNITS)

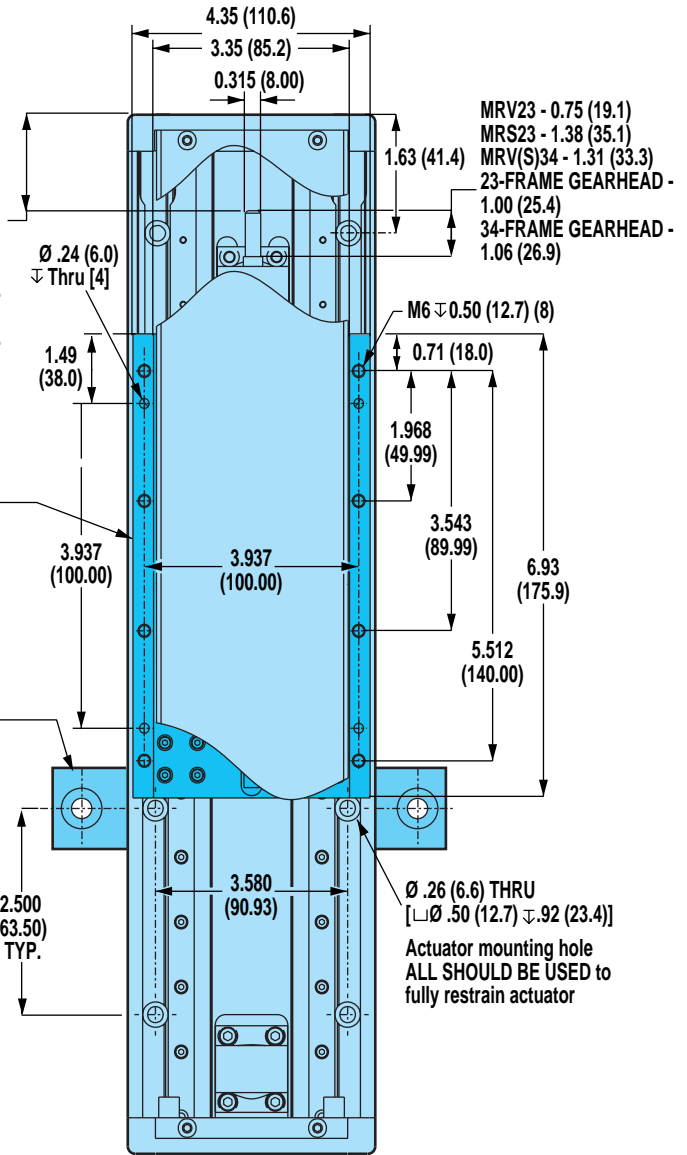
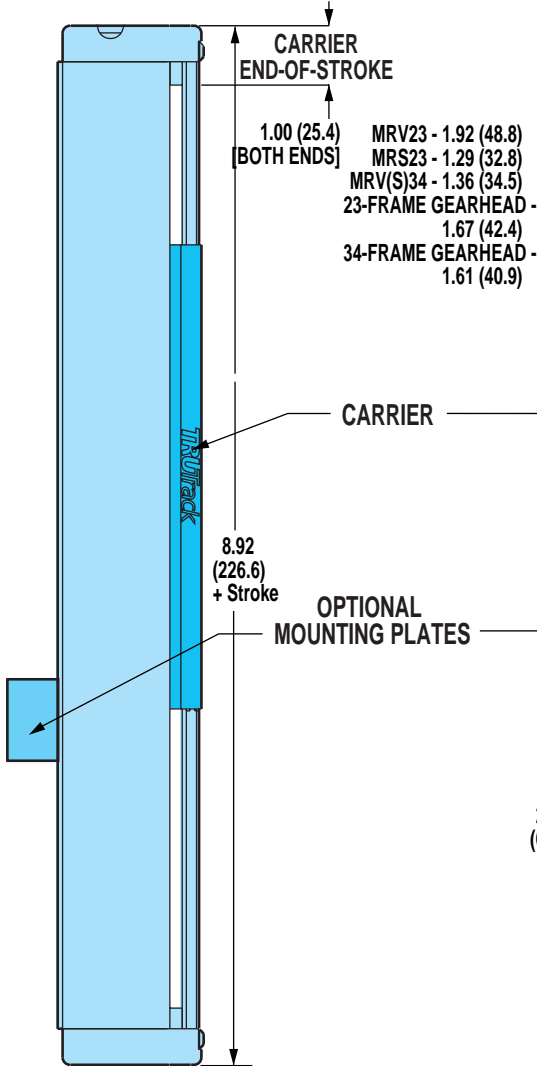

IDLE END (MOTOR END REVERSE PARALLEL (RP) UNITS)

IDLE END (MOTOR END REVERSE PARALLEL (RP) UNITS)

WHEN SPECIFYING THE XY/XJ SHAFT OPTION: IF A TOL-O-MATIC MOTOR IS NOT SPECIFIED IN THE CONFIGURATION STRING, CUSTOMER'S MOTOR MUST CONFORM TO THE SHAFT DIMENSIONS SHOWN FOR MOUNTING COMPATIBILITY. PLEASE SPECIFY YOUR MOTOR TYPE AND FRAME SIZE WHEN ORDERING.

Unless otherwise noted, all dimensions shown are in inches (Dimensions in parenthesis are in millimeters)

Axi-dyne[®] TRUtrack™ TKS25 Series

DIMENSIONS

TKS25: DOUBLE C-FACE BRAKE OPTION

BRAKE FOR 23-FRAME MOTOR

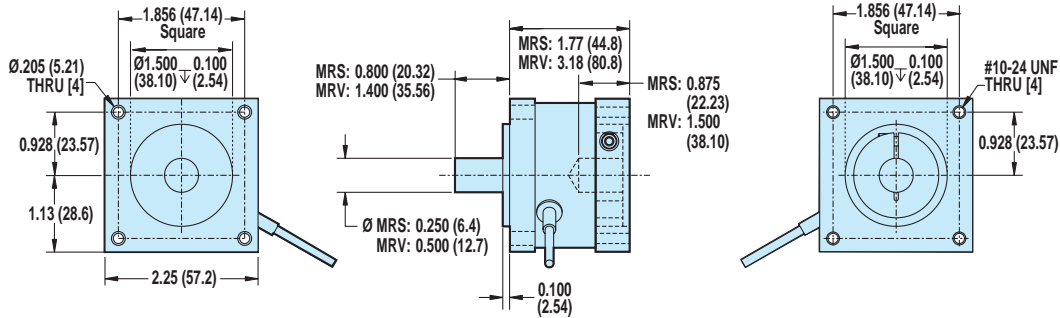

BRAKE FOR 34-FRAME MOTOR

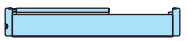
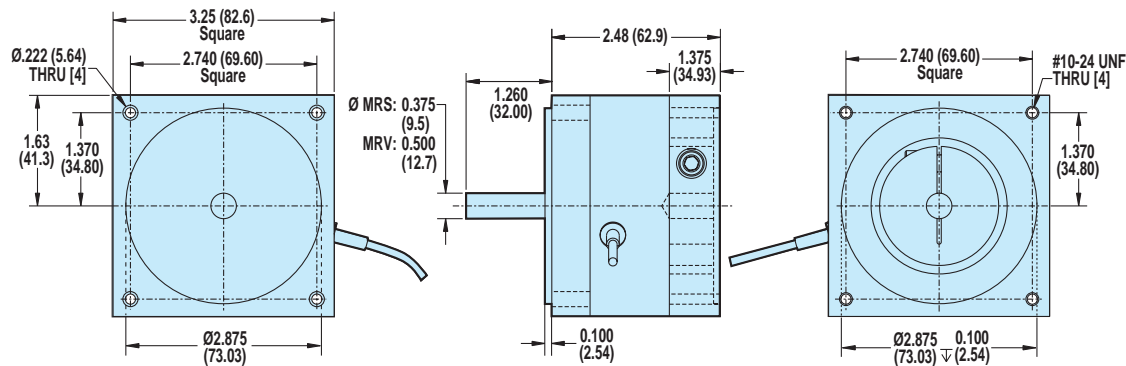

RODLESS

TKS25 Series

- Double C-face brake option dimensions

MOTOR TYPE	MOTOR/ FRAME	BRAKE PART NO.	STATIC TORQUE		REFLECTED INERTIA		WEIGHT		VOLTAGE	CURRENT	RESISTANCE	CABLE LENGTH	
			lb-in	N-m	lb-in ²	kg-M ² x10 ⁻⁶	lb	kg				in	mm
BRUSHLESS	MRV 23	3600-6286	10	1.130	0.0125	3.66	10.6	0.48	24	0.182	132.0	16.75	425
	MRV 34	3600-6288	25	2.825	0.1087	31.79	2.88	1.31	24	0.369	65.1	18.0	457
STEPPER	MRS 23	3600-6287	10	1.130	0.0125	3.66	10.6	0.48	24	0.182	132.0	16.75	425
	MRS 34	3600-6286	25	2.825	0.1087	31.79	2.88	1.31	24	0.369	65.1	18.0	457

MAXIMUM BRAKE HOLDING LOADS												
LEADSCREW/NUT REDUCTION	23-FRAME BRAKE						34-FRAME BRAKE					
	INLINE		5.5:1 GEARHEAD		10:1 GEARHEAD		INLINE		5.5:1 GEARHEAD		10:1 GEARHEAD	
	lb	kg	lb	kg	lb	kg	lb	kg	lb	kg	lb	kg
TKS25 with SN02	180	81.6	180	81.6	180	81.6	180	81.6	180	81.6	180	81.6
TKS25 with BN02	140	63.5	903	409.5	1643	745.2	349	158.3	2259	1024.6	4107	1862.8
TKS25 with BN05	349	158.3	2259	1024.6	4008	1817.9	873	395.9	4008	1817.9	4008	1817.9

⚠ Double C-face brakes are used for static holding (back driving prevention) and are not designed for dynamic stopping. Please contact Tol-O-Matic if your application requires dynamic stopping. This brake can be used with other Tol-O-Matic systems. Consult the factory for availability.

Axi dyne[®] TRUTrack™ TKS25 Series

DIMENSIONS

**TKS25: IN-LINE MOUNT FOR 34-FRAME BRUSHLESS (MRV) MOTORS,
34-FRAME STEPPER (MRS) MOTORS OR 34-FRAME GEARHEAD**



RODLESS

TKS Series
• In-line motor mounting

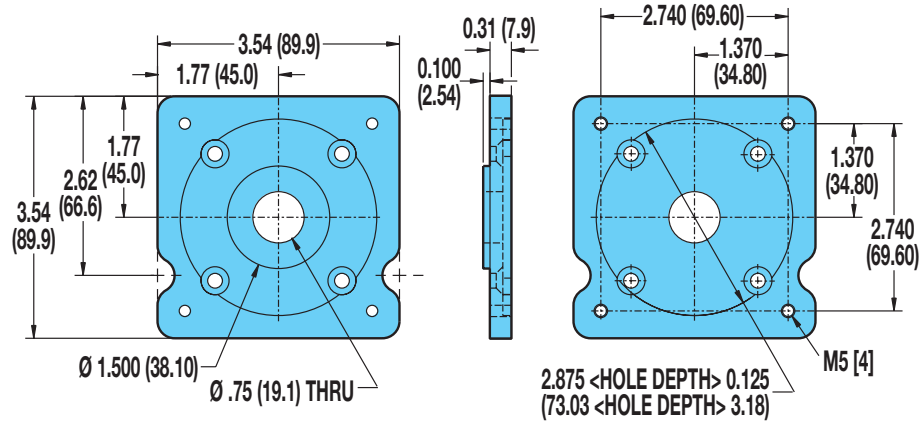

! *23-frame stepper MRS or brushless MRV motors are mounted directly to the actuator head and require no motor adapter plates. 34-frame stepper MS or brushless MRV motors cannot be mounted directly to the actuator head and require the use of the motor adapter plate shown.*



INTERCHANGING MOTORS: Leadscrews on TruTrack actuators are specific to the motor type specified. Motor mounting plates do not provide for interchanging servo or stepper motors.

For a complete part listing of screw-drive motor and gearhead mounting kits referencing actuator/motor/coupler compatibilities, refer to document 3600-4631 available on the Literature/Part Sheet/Axidyne section of our web site at: www.tolomatic.com.

For gearhead dimensions and specifications, refer to page F-10

Axi^{dyne}® TRUtrack™ TKS25 Series

DIMENSIONS

TKS25: REVERSE PARALLEL MOUNTING

BOTTOM MOUNT

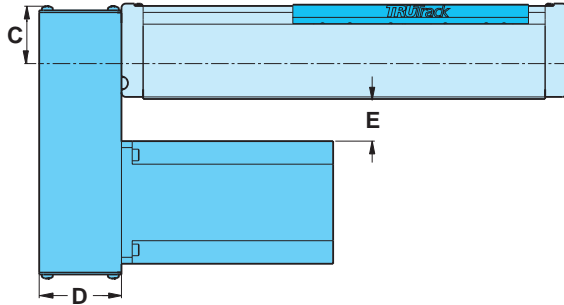
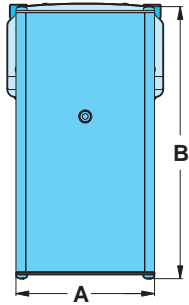

TOP MOUNT

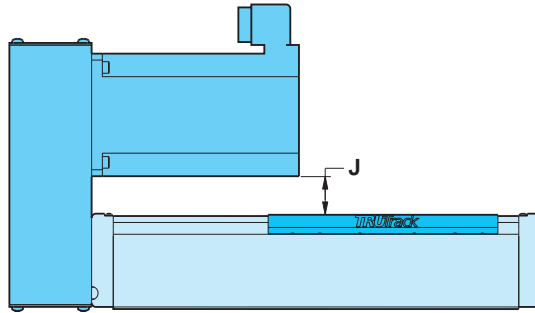
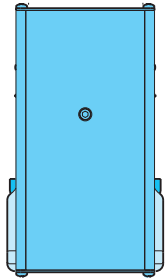

SIDE MOUNT

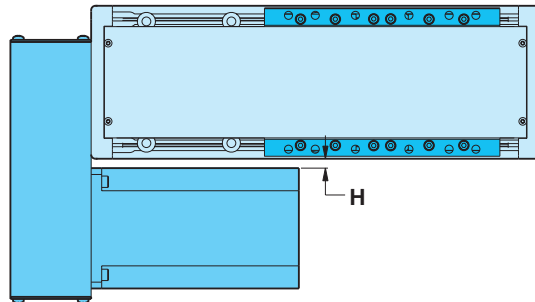
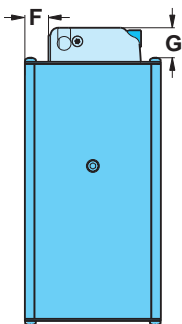

SPECIFICATIONS

	MOTOR	WEIGHT OF REDUCTION DRIVE			
		1:1		2:1	
		lbs	kg	lbs	kg
BRUSHLESS	MRV21, 22, 23, 24	2.51	1.14	2.74	1.24
	MRV31, 32, 33	2.75	1.25	2.98	1.35
STEPPER	MRS231, 232	2.07	0.94	2.30	1.04
	MRS341, 342, 343	2.17	0.99	2.34	1.06

	MOTOR	REDUCTION INERTIA AT MOTOR SHAFT			
		1:1		2:1	
		in-lb ²	kg-m ² x 10 ⁻⁴	in-lb ²	kg-m ² x 10 ⁻⁴
BRUSHLESS	MRV21, 22, 23, 24	0.038	11.115	0.103	30.128
	MRV31, 32, 33	0.038	11.115	0.103	30.128
STEPPER	MRS231, 232	0.033	9.653	0.061	17.696
	MRS341, 342, 343	0.051	14.918	0.118	34.442

REDUCTION EFFICIENCY: 0.95

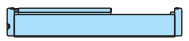

RODLESS

TKS25 Series

- Reverse parallel mounting

DIMENSIONS

	MOTORS	A		B		C		D		E		F		G		H		J	
		in.	mm	in.	mm	in.	mm	in.	mm	in.	mm	in.	mm	in.	mm	in.	mm	in.	mm
BRUSHLESS	MRV21, 22, 23, 24	3.25	82.6	7.02	178.4	1.33	33.8	2.13	54.1	1.74	44.2	0.32	8.1	1.07	27.2	0.80	20.3	1.78	45.2
	MRV31, 32, 33	4.00	101.6	7.79	197.9	1.33	33.8	2.38	60.5	0.97	24.6	0.69	17.5	1.07	27.2	0.15	3.8	1.01	25.7
STEPPER	MRS231, 232	3.25	82.6	7.02	178.3	1.33	33.8	2.13	54.1	1.74	44.2	0.32	8.1	1.07	27.2	0.80	20.3	1.78	45.2
	MRS341, 342, 343	4.00	101.6	7.79	197.9	1.33	33.8	2.38	60.5	1.05	26.7	0.69	17.5	1.07	27.2	0.23	5.8	1.09	27.7



Axi-dyne® TRUTrack™ TKS50 Series ACME SCREW SPECIFICATIONS

TKS50 ACME SCREW CRITICAL SPEED AND PV LIMITS

CRITICAL SPEED WITH 0.750" ITPI ENGLISH ACME SCREW

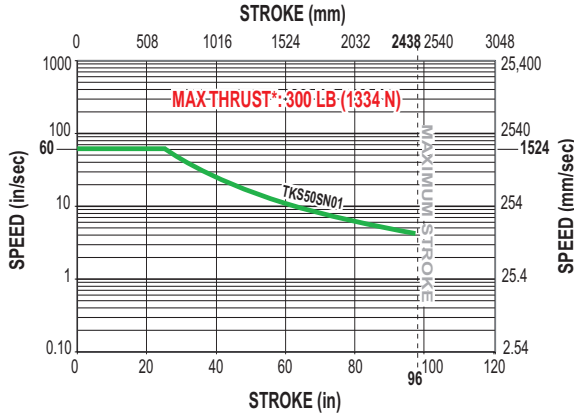

PV LIMITS: 0.750" ITPI ENGLISH ACME SCREW

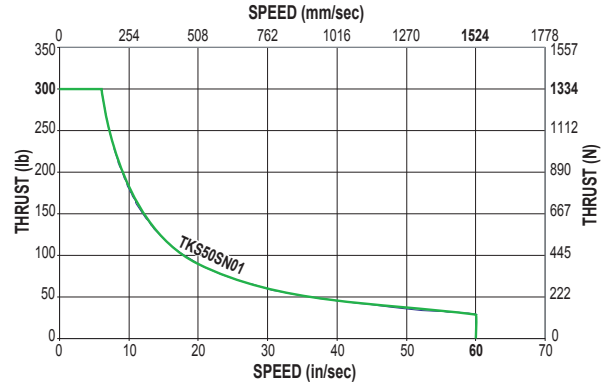

RODLESS

TKS50 Series

- Acme screw critical speed capacities and PV limits

SN = Solid Nut



* *Maximum thrust is the maximum continuous dynamic thrust subject to Thrust x Velocity limitation.*

PV LIMITS: Any material which carries a sliding load is limited by heat buildup. The factors that affect heat generation rate in an application are the pressure on the nut in pounds per square inch and the surface velocity in feet per minute. The product of these factors provides a measure of the severity of an application.

$$P = \frac{\text{Thrust}}{\text{Max. Thrust Rating}} \times V = \frac{\text{Speed}}{\text{Max. Speed Rating}} \leq 0.1$$

Axi-dyne® TRUTrack™ TKS50 Series

BALL SCREW SPECIFICATIONS

TKS50 BALL SCREW CRITICAL SPEED AND LIFE CALCULATIONS

CRITICAL SPEED WITH 0.750" 2TPI ENGLISH BALL SCREW

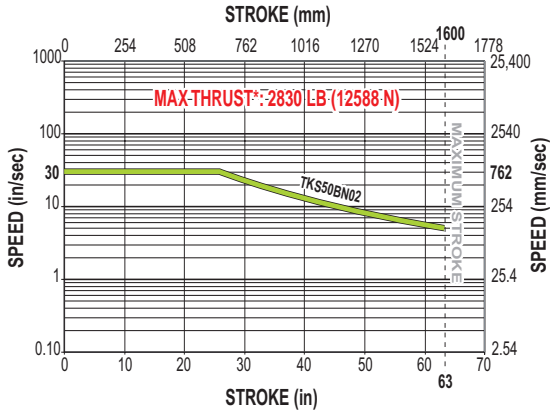

LIFE CALCULATION: 0.750" 2TPI ENGLISH BALL SCREW

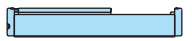
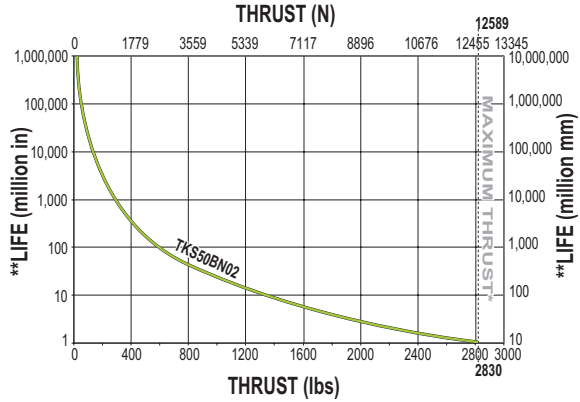

RODLESS

TKS50 Series

- Ball screw critical speed capacities and life calculations

CRITICAL SPEED WITH 0.750" 5TPI ENGLISH BALL SCREW

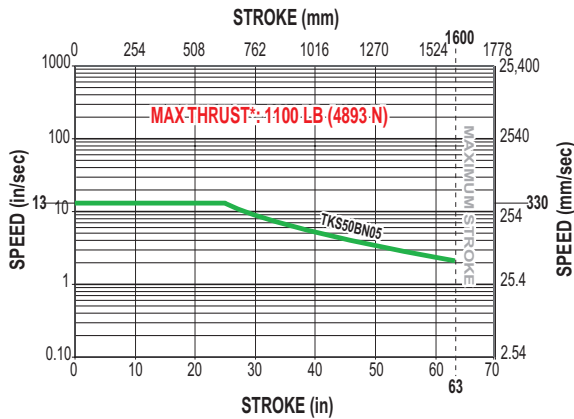

LIFE CALCULATION: 0.750" 5TPI ENGLISH BALL SCREW

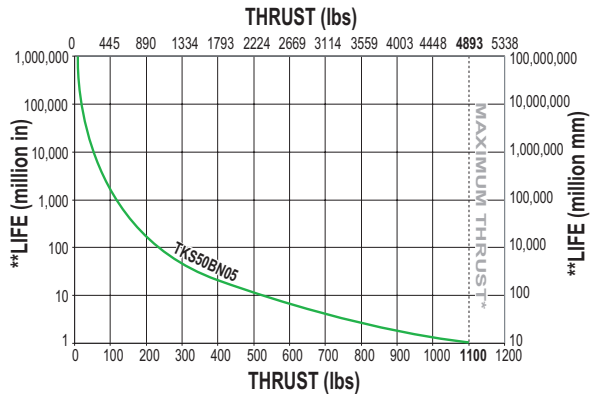

BN = Ball Nut



* Maximum thrust reflects 90% reliability for 1 million linear inches of travel.

**Life indicates theoretical maximum life of screw only, under ideal conditions and does not indicate expected life of actuator.

Axi-dyne[®] TRUTrack™ TKS50 Series

DIMENSIONS

TKS50 ACTUATOR AND OPTIONS DIMENSIONS



RODLESS

TKS50 Series
• Actuator and option dimensions

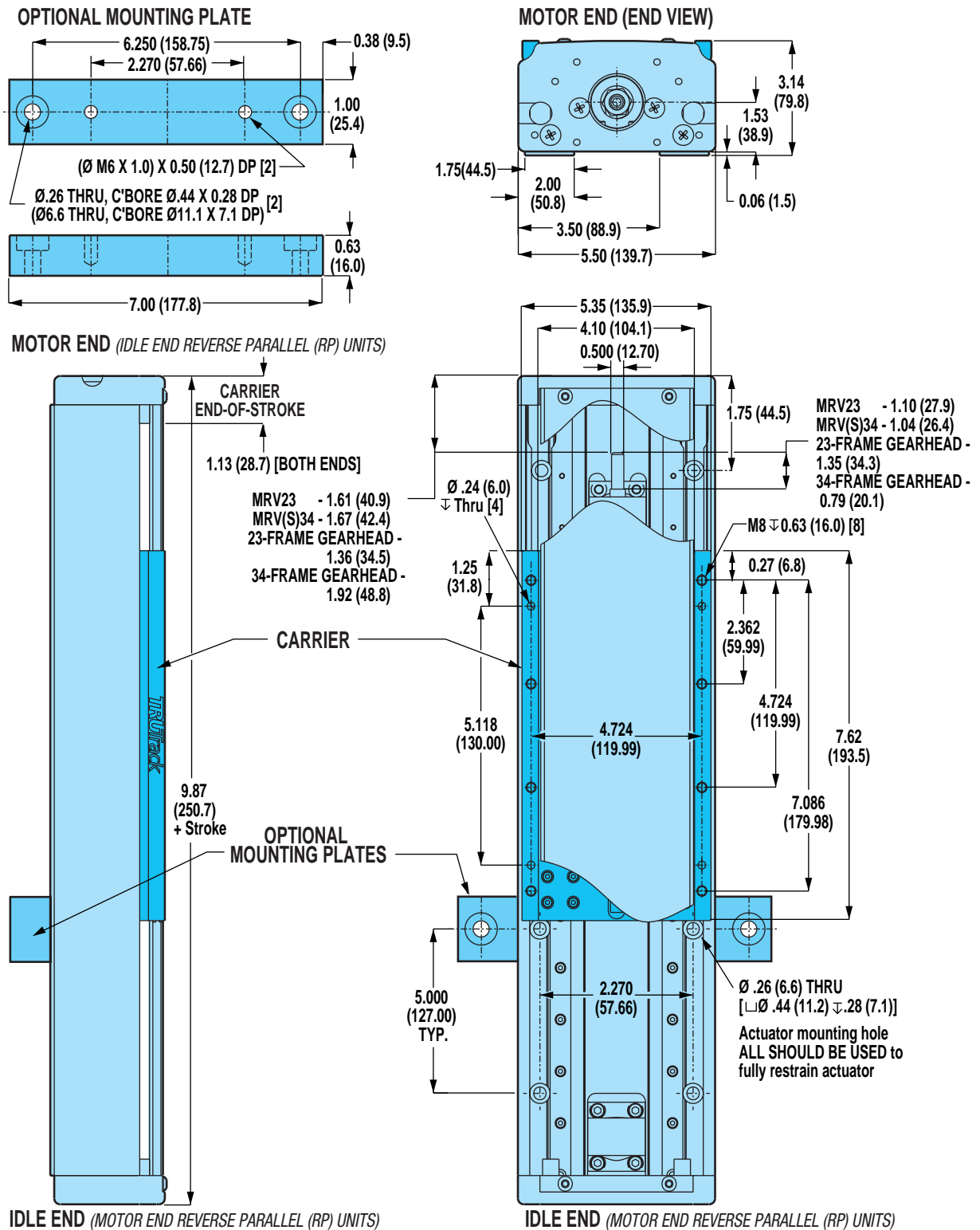

WHEN SPECIFYING THE XY/XJ SHAFT OPTION: IF A TOL-O-MATIC MOTOR IS NOT SPECIFIED IN THE CONFIGURATION STRING, CUSTOMER'S MOTOR MUST CONFORM TO THE SHAFT DIMENSIONS SHOWN FOR MOUNTING COMPATIBILITY. PLEASE SPECIFY YOUR MOTOR TYPE AND FRAME SIZE WHEN ORDERING.

Unless otherwise noted, all dimensions shown are in inches (Dimensions in parenthesis are in millimeters)

Axi-dyne[®] TRUTrack™ TKS50 Series

DIMENSIONS

TKS50: DOUBLE C-FACE BRAKE OPTION

BRAKE FOR 23-FRAME MOTOR

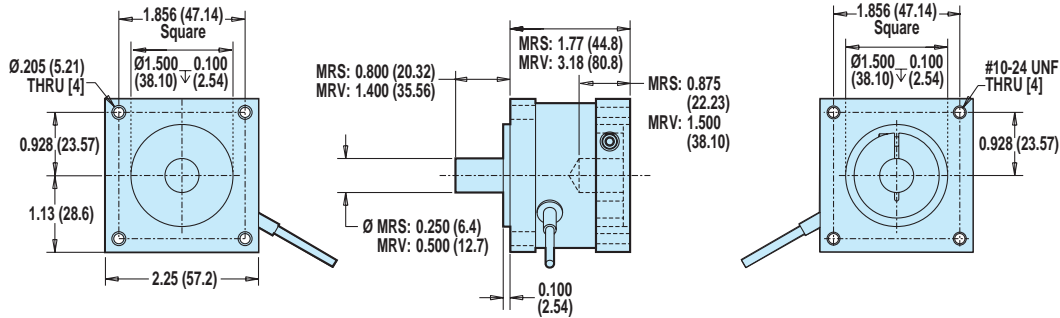

BRAKE FOR 34-FRAME MOTOR

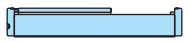
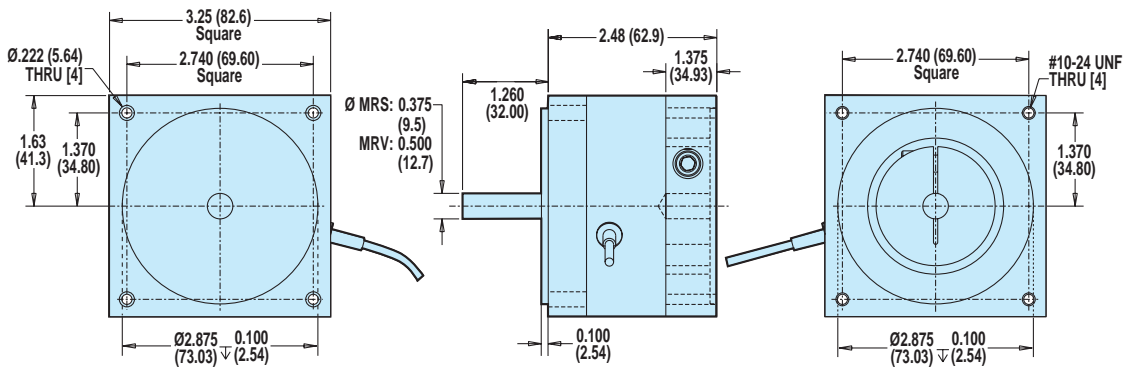

RODLESS

TKS50 Series

- Double C-face brake option dimensions

MOTOR TYPE	MOTOR/ FRAME	BRAKE PART NO.	STATIC TORQUE		REFLECTED INERTIA		WEIGHT		VOLTAGE	CURRENT	RESISTANCE	CABLE LENGTH	
			lb-in	N-m	lb-in ²	kg-m ² x 10 ⁻⁴	lb	kg	Vdc	Amps	Ohms	in	mm
BRUSHLESS	MRV 23	3600-6286	10	1.130	0.0125	3.66	10.60	0.48	24	0.182	132.0	16.75	425
	MRV 34	3600-6288	25	2.825	0.1087	31.79	2.88	1.31	24	0.369	65.1	18.00	457
STEPPER	MRS 23	3600-6287	10	1.130	0.0125	3.66	10.60	0.48	24	0.182	132.0	16.75	425
	MRS 34	3600-6286	25	2.825	0.1087	31.79	2.88	1.31	24	0.369	65.1	18.00	457

MAXIMUM BRAKE HOLDING LOADS

LEADSCREW/NUT REDUCTION	23-FRAME BRAKE						34-FRAME BRAKE					
	INLINE		5.5:1 GEARHEAD		10:1 GEARHEAD		INLINE		5.5:1 GEARHEAD		10:1 GEARHEAD	
	lb	kg	lb	kg	lb	kg	lb	kg	lb	kg	lb	kg
TKS50 with SN01	105	47.6	300	136.0	300	136.0	262	118.8	300	136.0	300	136.0
TKS50 with BN02	140	63.5	903	409.5	1643	745.2	349	158.3	2259	1024.6	4107	1862.8
TKS50 with BN05	349	158.3	2259	1024.6	4107	1862.8	873	395.9	5647	2561.4	10055	4560.8

⚠ Double C-face brakes are used for static holding (back driving prevention) and are not designed for dynamic stopping. Please contact Tol-O-Matic if your application requires dynamic stopping. This brake can be used with other Tol-O-Matic systems. Consult the factory for availability.

Axi dyne[®] TRUTrack™ TKS50 Series

DIMENSIONS

**TKS50: IN-LINE MOUNT FOR 23-FRAME BRUSHLESS (MRV) MOTORS,
OR 23-FRAME GEARHEAD**

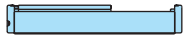

RODLESS

TKS50 Series

- In-line motor mounting dimensions

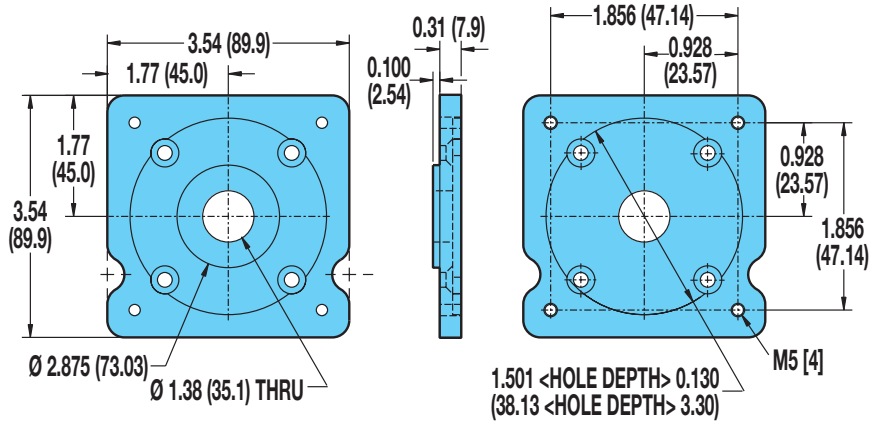

- ⚠ **34-frame stepper MRS or brushless MRV motors are mounted directly to the actuator head and require no motor adapter plates.**
- ⚠ **23-frame brushless MRV motors cannot be mounted directly to the actuator head and require the use of the adapter plate shown.**
- ⚠ **23-frame stepper MRS motors are not available on the TKS50.**

⚠ **INTERCHANGING MOTORS:** Leadscrews on TruTrack actuators are specific to the motor type specified. Motor mounting plates do not provide for interchanging servo or stepper motors.

For a complete part listing of screw-drive motor and gearhead mounting kits referencing actuator/motor/coupler compatibilities, refer to document 3600-4631 available on the Literature/Part Sheet/Axidyne section of our web site at: www.tolomatic.com.

For gearhead dimensions and specifications, refer to page F-10.

Axi-dyne® TRUTrack™ TKS50 Series

DIMENSIONS

TKS50: REVERSE PARALLEL MOUNTING

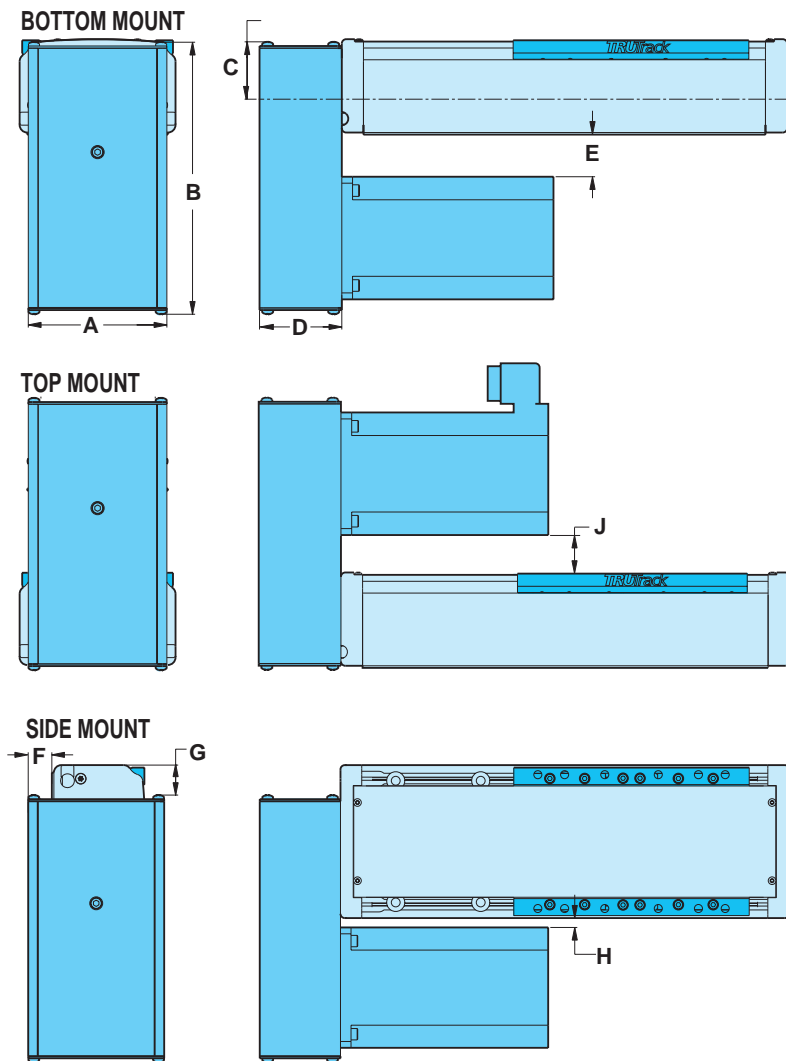

SPECIFICATIONS

	MOTOR	WEIGHT OF REDUCTION DRIVE			
		1:1		2:1	
		lbs	kg	lbs	kg
BRUSHLESS	MRV21, 22, 23, 24	2.85	1.29	3.08	1.40
	MRV31, 32, 33	3.40	1.54	3.56	1.62
STEPPER	MRS231, 232	2.67	1.21	2.90	1.32
	MRS341, 342, 343	3.20	1.45	3.36	1.52

	MOTOR	REDUCTION INERTIA AT MOTOR SHAFT			
		1:1		2:1	
		lb-in ²	kg-m ² x 10 ⁻⁶	lb-in ²	kg-m ² x 10 ⁻⁶
BRUSHLESS	MRV21, 22, 23, 24	0.036	10.530	0.103	30.054
	MRV31, 32, 33	0.036	10.530	0.103	30.054
STEPPER	MRS231, 232	0.024	7.020	0.060	17.623
	MRS341, 342, 343	0.051	14.918	0.118	34.442

REDUCTION EFFICIENCY: 0.95



RODLESS

TKS50 Series

- Reverse parallel mounting

DIMENSIONS

	MOTORS	A		B		C		D		E		F		G		H		J	
		in.	mm	in.	mm	in.	mm	in.	mm	in.	mm	in.	mm	in.	mm	in.	mm	in.	mm
BRUSHLESS	MRV21, 22, 23, 24	3.25	82.6	7.02	178.4	1.33	33.8	2.13	54.1	1.74	44.2	0.32	8.1	1.07	27.2	0.80	20.3	1.78	45.2
	MRV31, 32, 33	4.00	101.6	7.79	197.9	1.33	33.8	2.38	60.5	0.97	24.6	0.69	17.5	1.07	27.2	0.15	3.8	1.01	25.7
STEPPER	MRS231, 232	3.25	82.6	7.02	178.3	1.33	33.8	2.13	54.1	1.74	44.2	0.32	8.1	1.07	27.2	0.80	20.3	1.78	45.2
	MRS341, 342, 343	4.00	101.6	7.79	197.9	1.33	33.8	2.38	60.5	1.05	26.7	0.69	17.5	1.07	27.2	0.23	5.8	1.09	27.7



Axi dyne® TRUTrack™ TKS75 Series ACME SCREW SPECIFICATIONS

TKS75 ACME SCREW CRITICAL SPEED AND PV LIMITS

CRITICAL SPEED WITH 1" 4TPI ENGLISH ACME SCREW

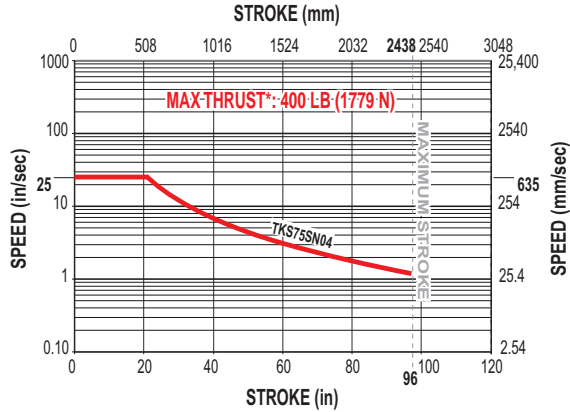

PV LIMITS: 1" 4TPI ENGLISH ACME SCREW

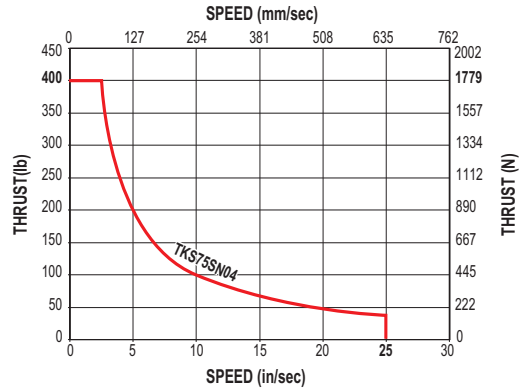

RODLESS

TKS75 Series

- Acme screw critical speed capacities and PV limits

SN = Solid Nut



* *Maximum thrust is the maximum continuous dynamic thrust subject to Thrust x Velocity limitation.*

PV LIMITS: Any material which carries a sliding load is limited by heat buildup. The factors that affect heat generation rate in an application are the pressure on the nut in pounds per square inch and the surface velocity in feet per minute. The product of these factors provides a measure of the severity of an application.

$$P = \frac{\text{Thrust}}{\text{Max. Thrust Rating}} \times V = \frac{\text{Speed}}{\text{Max. Speed Rating}} \leq 0.1$$

Axi-dyne[®] TRUTrack™ TKS75 Series

BALL SCREW SPECIFICATIONS

TKS75 BALL SCREW CRITICAL SPEED AND LIFE CALCULATIONS

CRITICAL SPEED WITH 0.927" ITPI ENGLISH BALL SCREW

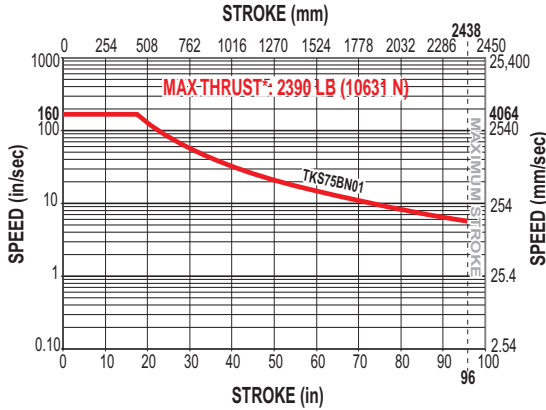

LIFE CALCULATION: 0.927" ITPI ENGLISH BALL SCREW

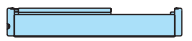
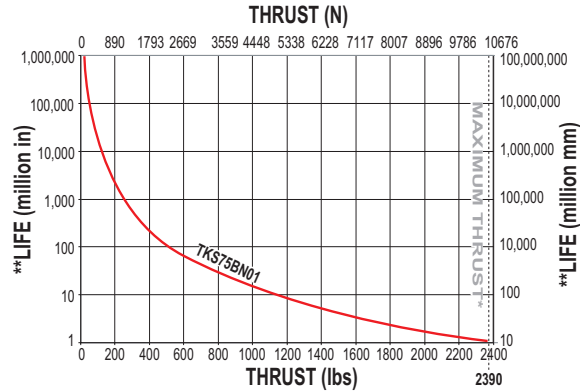

RODLESS

TKS75 Series

- Ball screw critical speed capacities and life calculations

CRITICAL SPEED WITH 0.957" 4TPI ENGLISH BALL SCREW

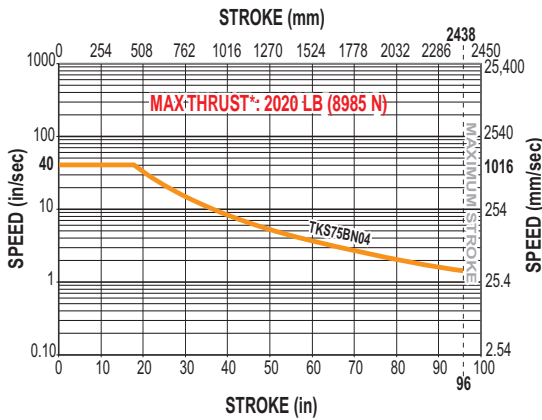

LIFE CALCULATION: 0.957" 4TPI ENGLISH BALL SCREW

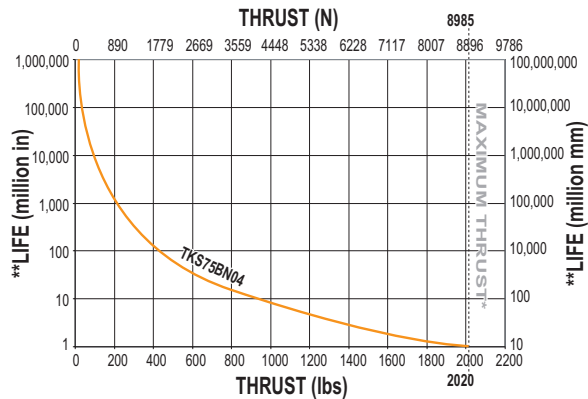

CRITICAL SPEED WITH 1" 2TPI ENGLISH BALL SCREW

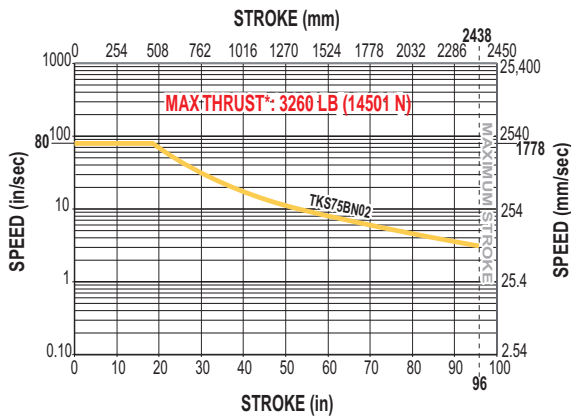

LIFE CALCULATION: 1" 2TPI ENGLISH BALL SCREW

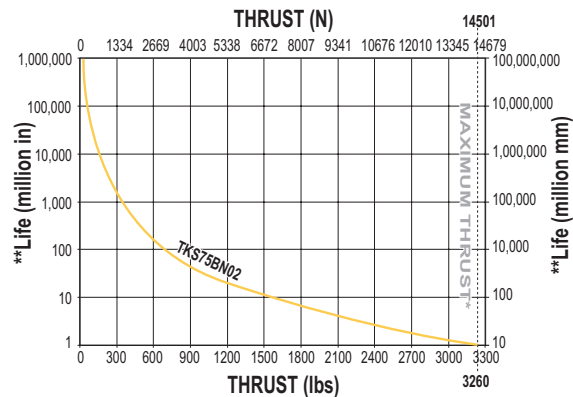

BN = Ball Nut



* Maximum thrust reflects 90% reliability for 1 million linear inches of travel.

**Life indicates theoretical maximum life of screw only, under ideal conditions and does not indicate expected life of actuator.

Axi-dyne[®] TRUTrack™ TKS75 Series

DIMENSIONS

TKS75 ACTUATOR AND OPTIONS



RODLESS

TKS75 Series
• Actuator and options dimensions

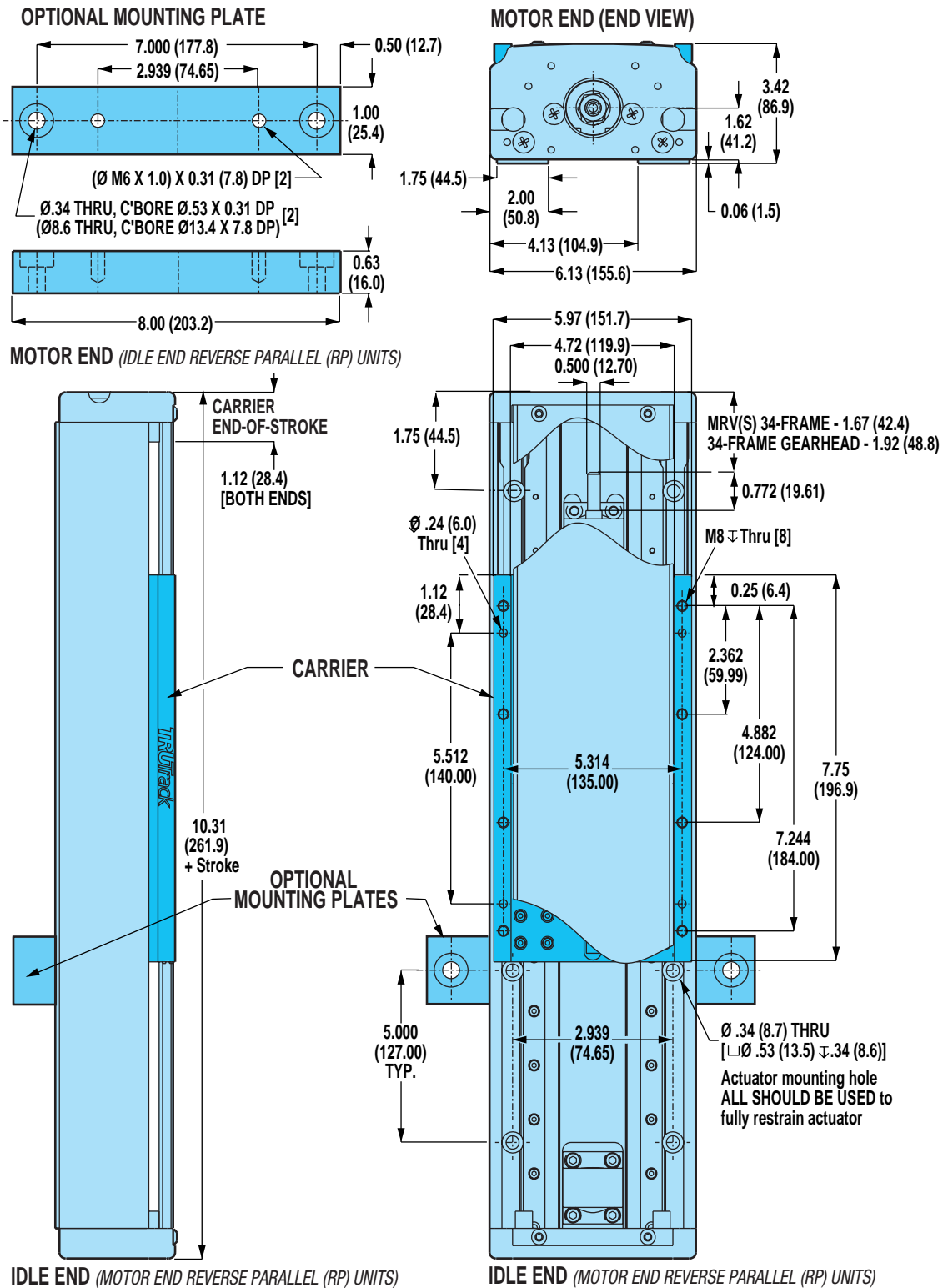

WHEN SPECIFYING THE XY/XJ SHAFT OPTION: IF A TOL-O-MATIC MOTOR IS NOT SPECIFIED IN THE CONFIGURATION STRING, CUSTOMER'S MOTOR MUST CONFORM TO THE SHAFT DIMENSIONS SHOWN FOR MOUNTING COMPATIBILITY. PLEASE SPECIFY YOUR MOTOR TYPE AND FRAME SIZE WHEN ORDERING.

Unless otherwise noted, all dimensions shown are in inches (Dimensions in parenthesis are in millimeters)

Axi-dyne® TRUTrack™ TKS75 Series

DIMENSIONS

TKS75: DOUBLE C-FACE BRAKE OPTION

BRAKE FOR 34-FRAME MOTOR

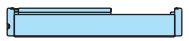
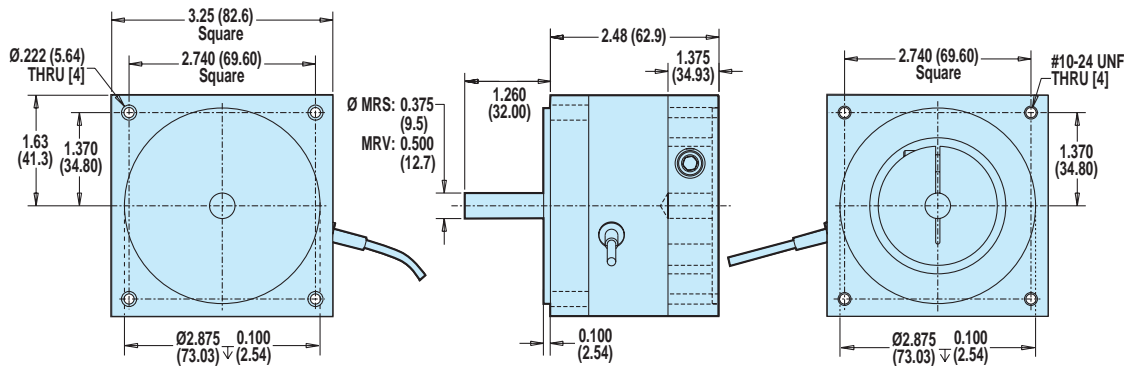

RODLESS

TKS75 Series

- Double C-face brake option
- In-line motor mounting

MOTOR TYPE	MOTOR/FRAME	BRAKE PART NO.	STATIC TORQUE		REFLECTED INERTIA		WEIGHT		VOLTAGE	CURRENT	RESISTANCE	CABLE LENGTH	
			lb-in	N-m	lb-in ²	kg-m ² x 10 ⁻⁶	lb	kg				in	mm
BRUSHLESS	MRV 34	3600-6288	25	2.825	0.1087	5.47	2.88	1.31	24	0.369	65.1	18.0	457
STEPPER	MRS 34	3600-6286	25	2.825	0.1087	5.47	2.88	1.31	24	0.369	65.1	18.0	457

MAXIMUM BRAKE HOLDING LOADS

LEADSCREW/NUT REDUCTION	34-FRAME BRAKE					
	INLINE		5.5:1 GEARHEAD		10:1 GEARHEAD	
	lb	kg	lb	kg	lb	kg
TKS75 with SN04	419	190.0	419	190.0	419	190.0
TKS75 with BN01	175	79.3	1129	512.1	2053	931.2
TKS75 with BN02	349	158.3	2259	1024.6	4107	1862.8
TKS75 with BN04	698	316.6	4517	2048.8	8213	3725.3

⚠ Double C-face brakes are used for static holding (back driving prevention) and are not designed for dynamic stopping. Please contact Tol-O-Matic if your application requires dynamic stopping. This brake can be used with other Tol-O-Matic systems. Consult the factory for availability.

TKS75: IN-LINE MOTOR AND GEARHEAD MOUNTING

All brushless servo (MRV) or stepper (MRS) 34-frame motors and gearheads may be mounted directly to the actuator head and do not require the use of motor adapter plates.

Reference the MOTOR END (END VIEW) in the dimensional drawing on page C-78



INTERCHANGING MOTORS: Leadscrews on TruTrack actuators are specific to the motor type specified. Motor mounting plates do not provide for interchanging servo or stepper motors.

For a complete part listing of screw-drive motor and gearhead mounting kits referencing actuator/motor/coupler compatibilities, refer to document 3600-4631 available on the Literature/Part Sheet/Axidyne section of our web site at: www.tolomatic.com.

For gearhead dimensions and specifications, refer to page F-10.

Axi-dyne® TRUtrack™ TKS75 Series

DIMENSIONS

TKS75: REVERSE PARALLEL MOUNTING

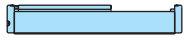

RODLESS

TKS75 Series
• Reverse parallel mounting

BOTTOM MOUNT

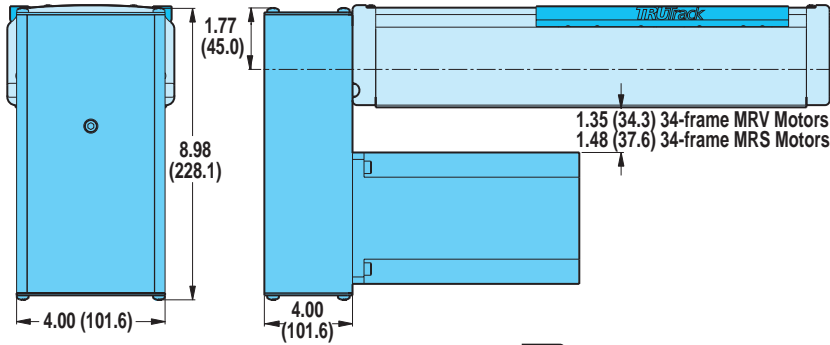

TOP MOUNT

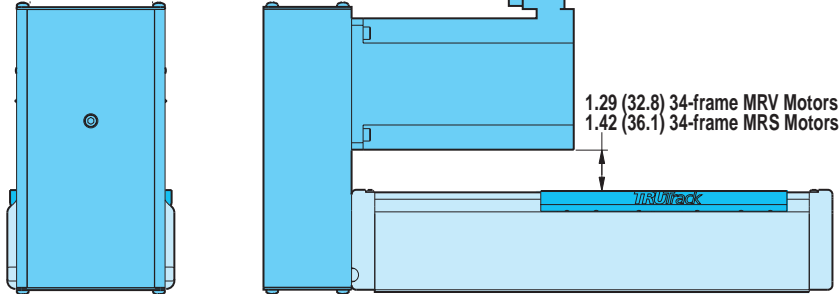

SIDE MOUNT

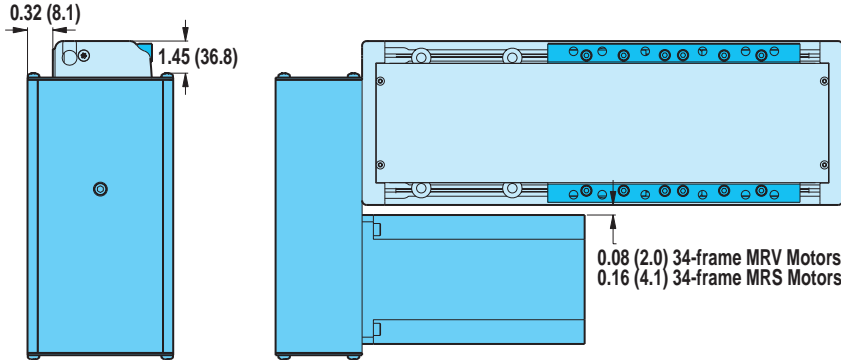

SPECIFICATIONS

	MOTOR	WEIGHT OF REDUCTION DRIVE				REDUCTION INERTIA AT MOTOR SHAFT			
		1:1		2:1		1:1		2:1	
		lbs	kg	lbs	kg	lb-in ²	kg-m ² x 10 ⁻⁴	lb-in ²	kg-m ² x 10 ⁻⁴
BRUSHLESS	MRV31, 32, 33	3.40	1.54	3.56	1.62	0.036	10.530	0.103	30.054
STEPPER	MRS341, 342, 343	3.20	1.45	3.36	1.52	0.051	14.918	0.118	34.442

REDUCTION EFFICIENCY: 0.95

Axi-dyne[®] TRUtrack™ TKS Screw Drives

ORDERING

BASE MODEL SPECIFICATIONS

TKS 50 BN02 SK55 LMB

OPTIONS SPECIFICATIONS

DC18 KT2 BE2 BRK LU MP4

MODEL TYPE

TKS TKS Series TruTrack English Screw Drive

PAYLOAD LIMITS

10	100 lbs	50	500 lbs
25	250 lbs	75	750 lbs

NUT/SCREW CONFIGURATION

ENGLISH MODELS

SOLID NUT / PITCH (turn/in)	SERIES
SN01	TKS50
SN02	TKS10, 25
SN04	TKS75

BALL NUT / PITCH (turn/in)	SERIES
BN01	TKS75
BN02	TKS25, 50, 75
BN04	TKS75
BN05	TKS25, 50
BN08	TKS10

STROKE LENGTH

SK Stroke, then enter desired stroke length in decimal inches

MODEL		MAX STROKE* (in)
TKS10	Ball Nut	29
	Solid Nut	96
TKS25	Ball Nut	63
	Solid Nut	96
TKS50	Ball Nut	63
	Solid Nut	96
TKS75	Ball/Solid Nut	96

*Actuator cover has maximum stroke of 48 inches

MOTOR MOUNTING / REDUCTIONS

▲ *The length on the leadscrew and coupling device is determined by motor selection. Motor type and frame size must be specified when ordering. Reference the ordering pages in sections F, G and H for the motor types and selections.*

(must choose one)

LMI In-Line mount
 LMB In-Line mount with brake
 LMG In-Line mount with gearhead
 RPL1 1:1 Reverse-Parallel mount left
 RPR1 1:1 Reverse-Parallel mount right
 RPB1 1:1 Reverse-Parallel mount bottom
 RPT1 1:1 Reverse-Parallel mount top
 RPL2 2:1 Reverse-Parallel mount left
 RPR2 2:1 Reverse-Parallel mount right
 RPB2 2:1 Reverse-Parallel mount bottom
 RPT2 2:1 Reverse-Parallel mount top

▲ *When the LMB option is selected, the configurator picks the appropriate screw and hardware to accommodate the mounting of the brake based on motor selection. The brake option "BRK" must also be indicated in the configuration string.*

When the LMG option is selected, the configurator picks the appropriate screw and hardware to accommodate the mounting of the gearhead based on motor selection. A gearhead reduction must also be indicated in the configuration string. Please reference the motor ordering pages for available options.

AUXILIARY CARRIER

DC_ Auxiliary Carrier, then center-to-center spacing desired in decimal inches. (Center-to-Center spacing will add to overall dead length and will not subtract from the stroke length)

SWITCHES

RT_ Reed Switch (Form A) with 5-meter lead, and quantity desired
 BT_ Reed Switch (Form C) with 5-meter lead, and quantity desired
 KT_ Hall-effect Sinking Switch with 5-meter lead, and quantity desired
 TT_ Hall-effect Sourcing Switch with 5-meter lead, and quantity desired
 SP*_ Sensor Package

*Includes: Two Form C reed switches w/5-meter leads, mounted 1" from end-of-stroke and one Hall-effect sinking switch w/5-meter lead, mounted 2" from end-of-stroke on motor end.

BELLOWS

BE2 Bellows option (increases the dead length of the actuator, see page C-58)

BRAKE OPTION

BRK In-line mounted brake***
 *** Used with the LMB in-line mounting option.

SPECIAL LUBRICATION

LU Low dust generating grease

MOUNTING PLATES

MP_ Mounting Plates plus quantity desired

▲ *Not all codes listed are compatible with all options.*

Use the Tol-O-Motion™ Sizing Software to determine available options and accessories based on your application requirements.

TO ORDER MOTORS/CONTROLS/INTERFACES

 BRUSHLESS SERVO (SEE PAGE F-33)

 MICROSTEPPING (SEE PAGE G-23)

 BRUSHED DC (SEE PAGE H-26)

FIELD RETROFIT KITS

ITEM	TKS10	TKS25	TKS50	TKS75
Mounting Plates	0601-9803	0602-9803	0603-9803	0604-9803

RODLESS

TKS75 Series

- Ordering

Customization, Tol-O-Matic does it every day

Tol-O-Matic's ability to provide creative and imaginative solutions for our customers has made us a world leader in the manufacture of automation components. Every Tol-O-Matic product is custom made specifically to your order. Our product line contains over 30,000 base models, most of these manufactured in customer specified strokes. Add on our wide variety of available options and Tol-O-Matic offers literally millions of choices to fit your application. Even with so many choices we encourage you to contact us with your "specials" requirements. We have the resources to create whatever it is you may need.



RODLESS

Exacting precision for a 5-axis milling machine.

Tol-O-Matic worked with this manufacturer to create a prototype specific to their application. Standard RSA rod screw actuators were completely modified with special bearings and precision-matched lead screws to provide the highest possible accuracy, rigidity and ultra low-backlash. A series of six Axidyne DV drives worked with their existing controls and proprietary software system to cue the six legs of actuator motion.

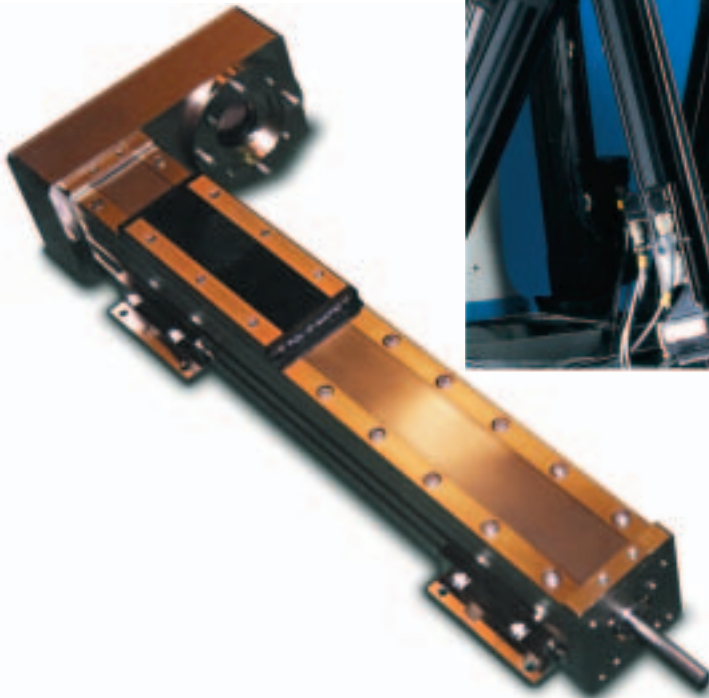
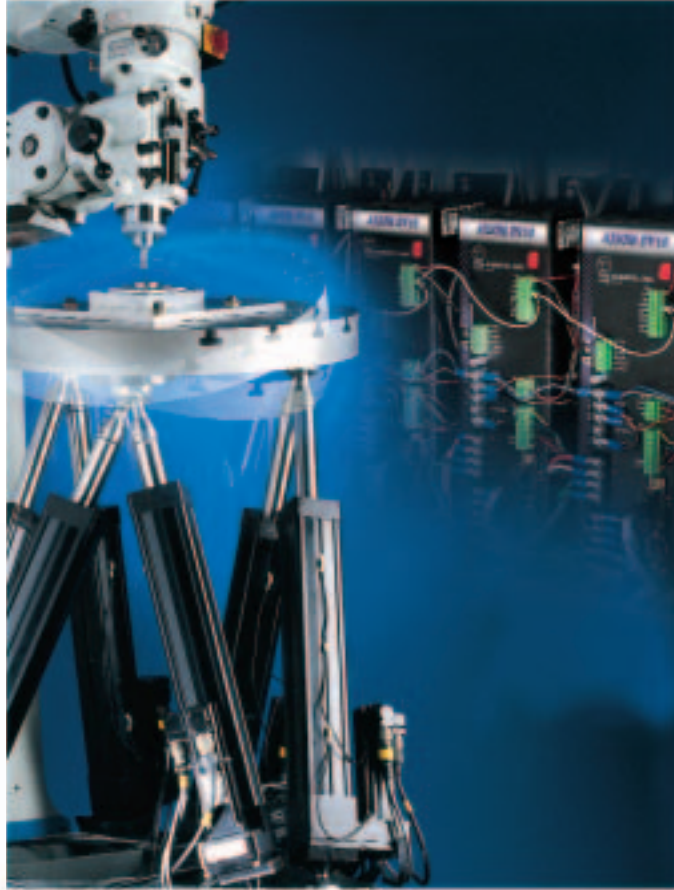

An actuator for an extremely corrosive environment

This standard B3S actuator has a nickel-plated extrusion, other components were made of stainless-steel. A special mounting bracket was created to use with a nonstandard motor.

YES, we can create it.

Tol-O-Matic has created hundreds of special proprietary products for a wide variety of different industries. From simple refinements like creating new mounting brackets or tapped holes to redesigning an existing product, or creating a completely new product, Tol-O-Matic has the resources available to design, test and manufacture whatever you need. Our engineers are available to visit your facility and discuss your special requirements.

Axi-dyne® TRUTrack™ TKB Belt Drives

OVERVIEW



APPLICATION BENEFITS

- Straightness and flatness within 0.0002 inches per inch
- Superior rigidity, high moment loads, faster speeds
- Lowest carrier deflection of any Tol-O-Matic actuator
- Excellent repeatability
- Wide stable platform for XY applications

GUIDANCE SYSTEM

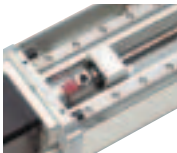

- Ground linear profiled rails and ball bearing blocks decrease deflection and provide smooth carrier/load movement

STANDARD MOUNTING

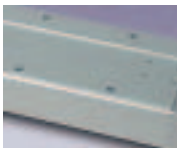

- Mounting holes are spaced the length of the actuator for ease in mounting directly to a flat surface.

ACTUATOR/MOTOR FACTORS

- Actuator's operating temperature range (40-130° F, 4-54° C) should take into consideration heat generated by the motor and drive, linear velocity and work cycle time.
- For large frame motors or small actuators, cantilevered motors need to be supported, if subjected to continuous rapid reversing duty and/or under dynamic conditions.

AVAILABLE OPTIONS



Mounting Plates: provide clearance height for motors and motor mounts when mounting on a flush surface. Recommended on all TruTrack actuators, they prevent actuator body deflections over .015 in (3.8mm).



Auxiliary Carrier: Increases rigidity, load-carrying capacity and bending moments



Bellows: protects from dust and dirt environments.



Motor Mounting and Gearhead Reduction:

Direct Drive Mounting— motor is mounted directly to the drive end assembly. Motor may be mounted directly on the left or right side.



Reduction Drive Mounting—motor is mounted to the reduction assembly, providing a speed reduction from the motor to the belt drive wheel. TKB actuators are available with a 1:1 or 2:1 reduction.



Gearhead Reduction—Gearheads are available for applications requiring reduction for inertia matching or higher torque at lower speeds. High efficiency, single stage, true planetary gearheads are available in 5.5:1 and 10:1 ratios for reduction solutions with most Tol-O-Matic NEMA 23- and 34-frame motors. For gearhead specifications and dimensions see page F-10.



Switches: Available in ac reed or dc Hall-effect. (TRIAC switches are not available on TruTrack actuators) See section I.



RODLESS

TKB Series

- Application benefits
- Guidance system
- Standard mounting
- Actuator/motor factors
- Available options

Axi-dyne® TRUTrack™ TKB Belt Drives

BELT PERFORMANCE

BELT FORCE AND SPEED CAPACITIES

BELT LOAD FOR TKB ENGLISH ACTUATORS

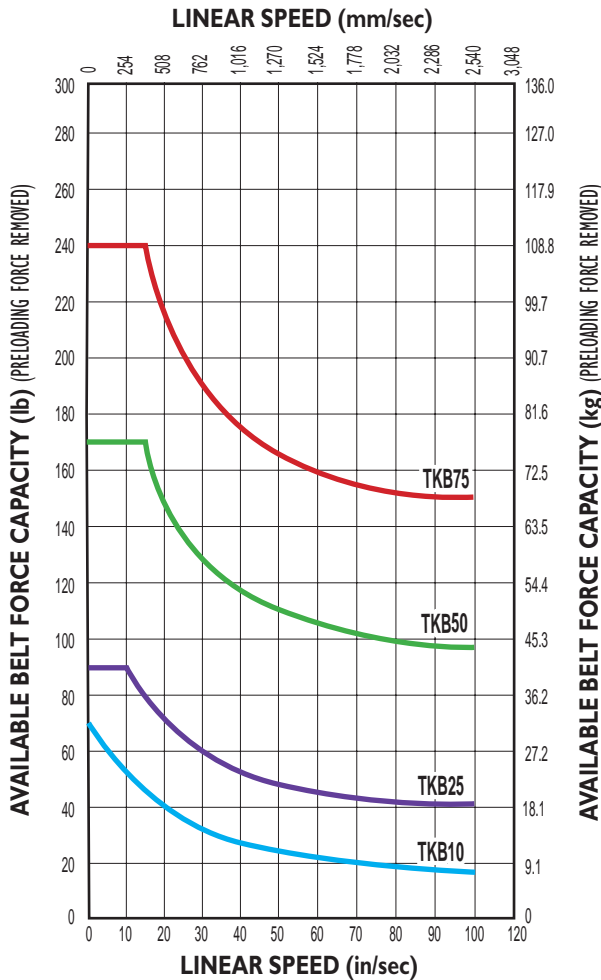

BELT SPEED FOR TKB ENGLISH ACTUATORS

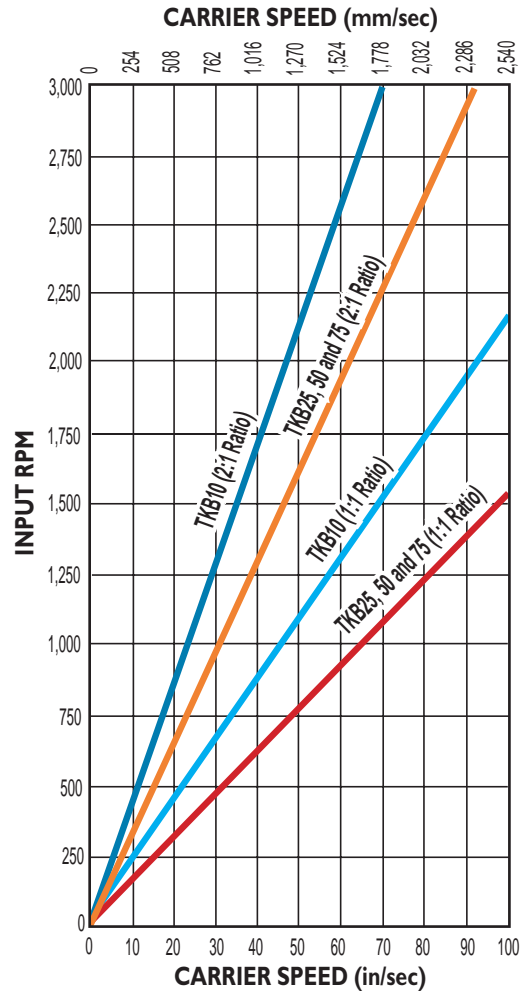

BELT SPECIFICATIONS

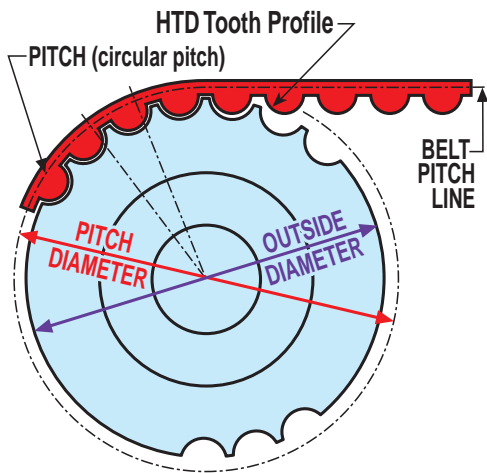

STYLE:	HTD Tooth
TOOTH PITCH:	5mm
BELT MATERIAL:	Neoprene body with Fiberglass tension members
CHARACTERISTICS:	<ul style="list-style-type: none"> • For higher speed, higher load applications • Heavy duty drive and idler pulley bearings

OVERALL SERIES SPECIFICATIONS

TKB BELT, INERTIA AND BREAKAWAY TORQUE SPECIFICATIONS

TKB ENGLISH ACTUATORS								
ACTUATOR SERIES	BELT WIDTH (in)	BELT WEIGHT (lb/in)	BELT DEAD LENGTH (in)	WHEEL PITCH DIA. (in)	PULLEY WHEELS INERTIA (lb-sq in)	INERTIA (lb-in ²)		BREAKAWAY TORQUE (LB-IN)
						BASE ACTUATOR	PER/INCH OF STROKE	
TKB10	0.59	0.0033	15.88	0.887	0.019	0.1668	0.0014	3.125
TKB25	1.00	0.0056	23.12	1.191	0.099	1.0996	0.0044	9.375
TKB50	1.57	0.0089	26.23	1.191	0.149	1.5722	0.0070	9.375
TKB75	1.97	0.0111	25.68	1.191	0.181	2.0350	0.0087	9.375

METRIC CONVERSIONS								
ACTUATOR SERIES	BELT WIDTH (mm)	BELT WEIGHT (g/cm)	BELT DEAD LENGTH (mm)	WHEEL PITCH DIA. (mm)	PULLEY WHEELS INERTIA (kg-m ² x 10 ⁻⁶)	INERTIA (kg-m ² x 10 ⁻⁶)		BREAKAWAY TORQUE (N-m)
						BASE ACTUATOR	PER/mm OF STROKE	
TKB10	15.0	1.50	403.4	22.5	131.94	48.80	0.41	0.35
TKB25	25.4	2.54	587.2	30.3	687.50	321.63	1.29	1.06
TKB50	40.0	4.04	666.2	30.3	1034.72	459.87	2.05	1.06
TKB75	50.0	5.04	652.3	30.3	1256.94	595.24	2.54	1.06



RODLESS

TKB Series

- Belt, inertia and breakaway torque specifications
- General actuator specifications

GENERAL ACTUATOR SPECIFICATIONS

ENGLISH MEASUREMENTS								
ACTUATOR SERIES	MAXIMUM STROKE (in)	CARRIER WEIGHT (lb)	DIRECT DRIVE BASE WEIGHT ¹ (lb)	WEIGHT PER/in OF STROKE (lb)	FLATNESS ZX PLANE (in/in) (Unconstrained ²)	STRAIGHTNESS YX PLANE (in/in) (Unconstrained ²)	STRAIGHTNESS & FLATNESS (in/in) (Constrained ²)	TEMP. RANGE ⁴ (F°)
TKB10	96	0.64	3.23	0.20	0.0008	0.0004	.0002	40°-130°
TKB25	96	2.41	10.69	0.46	0.0008	0.0004	.0002	40°-130°
TKB50	96	3.38	14.99	0.61	0.0008	0.0004	.0002	40°-130°
TKB75	96	4.42	18.34	0.72	0.0008	0.0004	.0002	40°-130°

METRIC CONVERSIONS								
ACTUATOR SERIES	MAXIMUM STROKE (mm)	CARRIER WEIGHT (kg)	DIRECT DRIVE BASE WEIGHT ¹ (kg)	WEIGHT PER/mm OF STROKE (kg)	FLATNESS ZX PLANE (mm/mm) (Unconstrained ²)	STRAIGHTNESS YX PLANE (mm/mm) (Unconstrained ²)	STRAIGHTNESS & FLATNESS (mm/mm) (Constrained ²)	TEMP. RANGE ⁴ (C°)
TKB10	2438	0.3	1.5	0.09	0.0008	0.0004	.05	4°-54°
TKB25	2438	1.1	4.8	0.21	0.0008	0.0004	.05	4°-54°
TKB50	2438	1.5	6.8	0.28	0.0008	0.0004	.05	4°-54°
TKB75	2438	2.0	8.3	0.32	0.0008	0.0004	.05	4°-54°



¹ Weight includes carrier without motor.

² Listed values are intended for reference purposes only, and not as an engineering standard of absolute tolerance for a given actuator. Values were derived from testing of characteristic samples of appropriate products, and indicate an expected range of deviation from a theoretical straight line in the indicated plane of carrier motion. Appropriate installation is the single most important factor in reducing such deviation, so good engineering practices such as measurement, mapping, etc. must be employed in applications with stringent straightness/flatness requirements. For more information on how these values were obtained, please read the white paper on this subject available at www.tolomatic.com.

³ Actuator mounted on a flat surface and fully restrained. (See dimensional drawings)

⁴ Heat generated by the motor and drive should be taken into consideration as well as linear velocity and work cycle time. For applications that require operation outside of the recommended temperature range, contact the factory.

LARGE FRAME MOTORS AND SMALLER SIZE ACTUATORS: Cantilevered motors need to be supported, if subjected to continuous rapid reversing duty and/or under dynamic conditions.

Axi-dyne[®] TRUTrack™ TKB Belt Drives

OVERALL SERIES SPECIFICATIONS

MOUNTING RECOMMENDATIONS

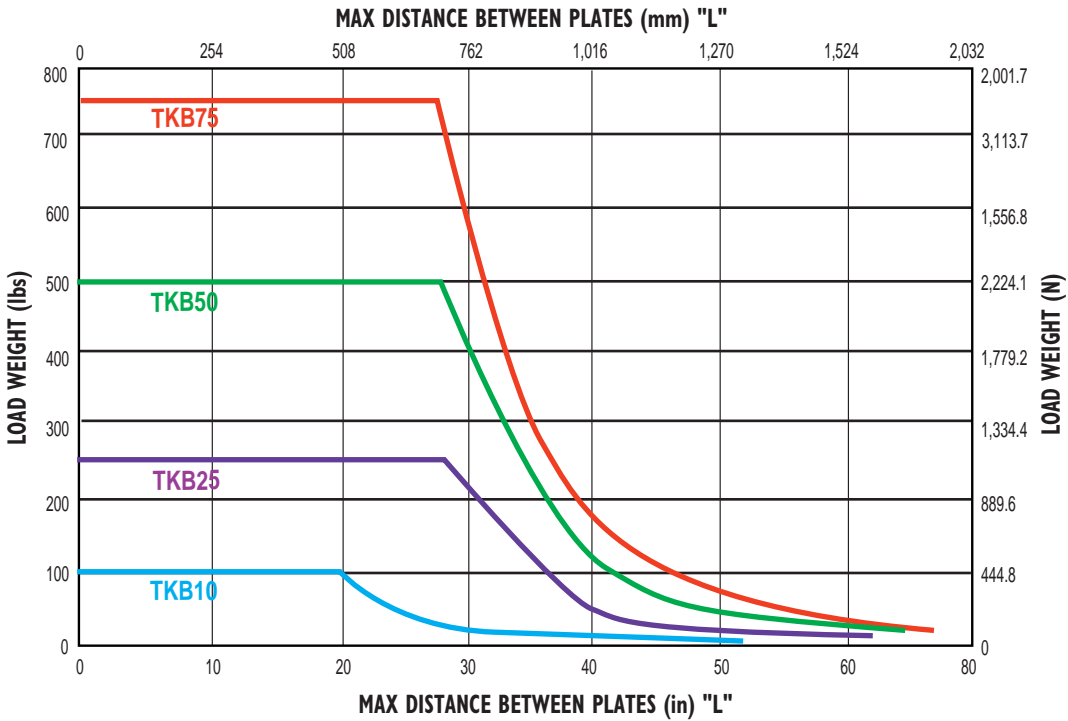

Actuator body theoretical axial deflection will not exceed .015 in (0.38 mm)

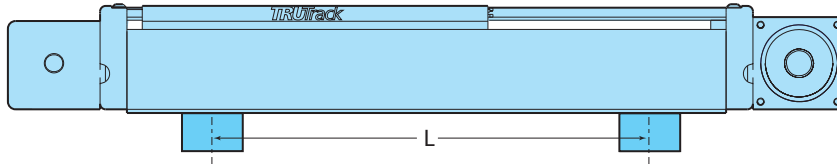

FRICITION FORCE

$$lbf = 0.0003 \times \text{LOAD (lb)} + 3.96$$

$$N = 0.003 \times \text{LOAD (kg)} + 17.6$$

Axi-dyne® TRUTrack™ TKB Belt Drives

OVERALL SERIES SPECIFICATIONS

BELLOWS OPTION STROKE REQUIREMENTS

STANDARD ACTUATOR

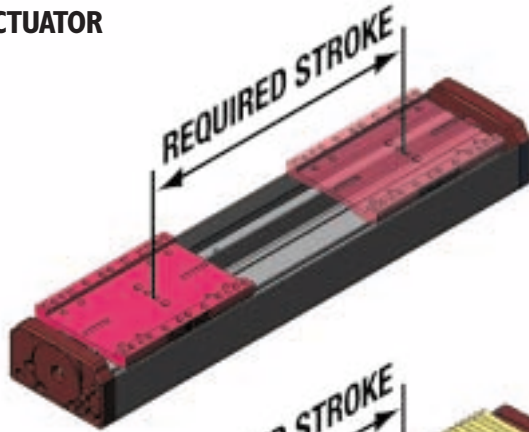

STANDARD ACTUATOR WITH BELLOWS COVER

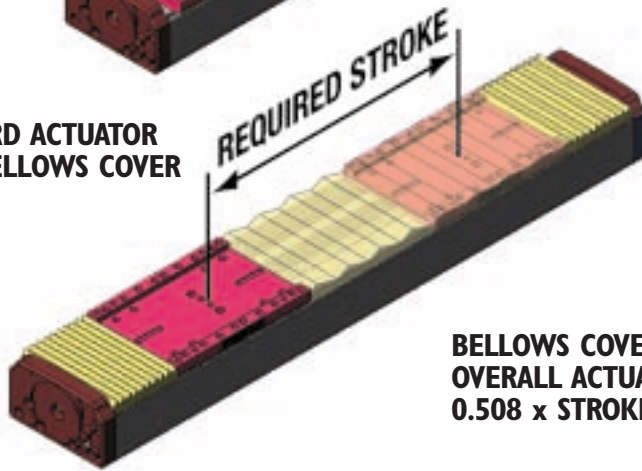

**BELLOWS COVER OPTION INCREASES
OVERALL ACTUATOR LENGTH BY
0.508 x STROKE**



RODLESS

TKB Series
• Bellows option

MAXIMUM AVAILABLE STROKE FOR BELLOWS OPTION

TKB10	64 inches (1626 mm)
TKB25	64 inches (1626 mm)
TKB50	64 inches (1626 mm)
TKB75	64 inches (1626 mm)

Axi-dyne® TRUTrack™ TKB Belt Drives

OVERALL SERIES SPECIFICATIONS

BENDING MOMENTS AND LOADS



RODLESS

TKB Series

- Bending moments and loads

STANDARD CARRIER	MAXIMUM BENDING MOMENTS AND LOADS*				ENGLISH				METRIC CONVERSIONS			
	TKB10	TKB25	TKB50	TKB75	TKB10	TKB25	TKB50	TKB75	TKB10	TKB25	TKB50	TKB75
	Maximum Dynamic Bending Moments											
	Mx (Roll)	(lb-in : N-m)	85	721	971	1151	9.6	81.5	109.7	130.0		
	My (Pitch)	(lb-in : N-m)	234	1014	1442	1477	26.4	114.6	162.9	166.9		
	Mz (Yaw)	(lb-in : N-m)	234	915	1301	1332	26.4	103.4	147.0	150.5		
	Maximum Dynamic Loads											
	Fy (Radial Load)	(lb : N)	100	250	500	750	445	1113	2225	3338		
	Fz (Lateral Load)	(lb : N)	100	250	500	750	445	1113	2225	2225		
	Fzr (Reverse Lateral Load)	(lb : N)	100	250	500	750	445	1113	2225	2225		
	Maximum Static Bending Moments											
	Mx (Roll)	(lb-in : N-m)	170	1251	1685	1997	19.2	141.3	190.3	225.6		
	My (Pitch)	(lb-in : N-m)	468	1759	2502	2563	52.9	198.8	282.7	289.5		
	Mz (Yaw)	(lb-in : N-m)	468	1588	2257	2311	52.9	179.4	255.0	261.1		
	Maximum Static Loads											
	Fy (Radial Load)	(lb : N)	200	434	868	1301	890	1931	3863	5789		
	Fz (Lateral Load)	(lb : N)	200	434	868	868	890	1931	3863	3863		
Fzr (Reverse Lateral Load)	(lb : N)	200	434	868	868	890	1931	3863	3863			
AUXILIARY CARRIER: Increases rigidity, load-carrying capacity and moments												
	Maximum Dynamic Bending Moments											
	Mx (Roll)	** (lb-in : N-m)	170	1442	1942	2302	19.2	162.9	219.4	260.1		
	My (Pitch)	** (lb-in : N-m)	563	1733	3810	3875	63.6	195.7	430.5	437.8		
	Mz (Yaw)	** (lb-in : N-m)	563	1733	3810	3875	63.6	195.7	430.5	437.8		
	Maximum Dynamic Loads											
	Fy (Radial Load)	(lb : N)	200	500	1000	1500	890	2225	4450	6675		
	Fz (Lateral Load)	(lb : N)	200	500	1000	1500	890	2225	4450	4450		
	Fzr (Reverse Lateral Load)	(lb : N)	200	500	1000	1500	890	2225	4450	4450		
	Maximum Static Bending Moments											
	Mx (Roll)	** (lb-in : N-m)	340	2502	3369	3994	38	283	381	451		
	My (Pitch)	** (lb-in : N-m)	1126	3006	6610	6723	127	340	747	760		
	Mz (Yaw)	** (lb-in : N-m)	1126	3006	6610	6723	127	340	747	760		
	Maximum Static Loads											
	Fy (Radial Load)	(lb : N)	400	868	1735	2603	1780	3863	7721	11583		
	Fz (Lateral Load)	(lb : N)	400	868	1735	1735	1780	3863	7721	7721		
Fzr (Reverse Lateral Load)	(lb : N)	400	868	1735	1735	1780	3863	7721	7721			
Minimum Dimension 'D'	(in : mm)	5.63	6.93	7.63	7.75	142.9	176.0	193.8	196.9			



* Bending moments are based on 200,000,000 (5,000 KM) linear inches of carrier travel.

Breakaway torque will increase when using the Auxiliary carrier option. When ordering, determine your working stroke and enter this value into the configuration string. Overall actuator length will automatically be calculated.

Deflection Considerations: In applications where substantial M_x or M_y moments come into play, deflection of the cylinder tube, carrier and supports must be considered. The deflection factors shown in the Load Deflection charts, are based on cylinder mounted with tube supports at minimum recommended spacing. If more rigidity is desired, refer to the Auxiliary or Dual Carrier options.

** Loads shown in table are at minimum "D" dimension, for ratings with longer "D" dimension see graph on page C-89.

Axi-dyne® TRUTrack™ TKB Belt Drives

OVERALL SERIES SPECIFICATIONS

LOAD DEFLECTION

X-AXIS DEFLECTION

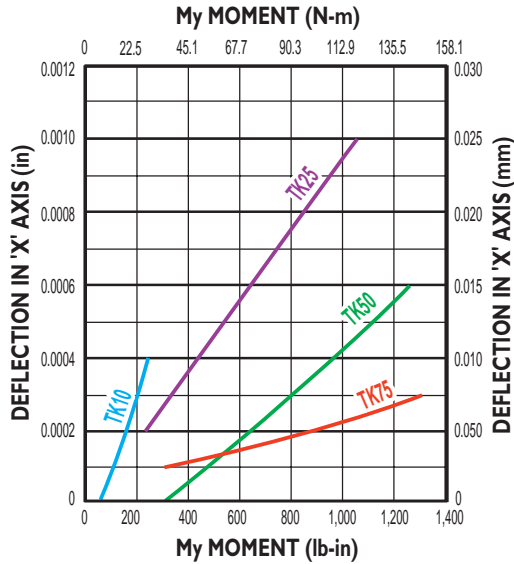
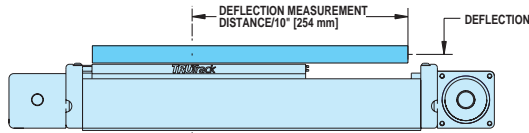

Y-AXIS DEFLECTION

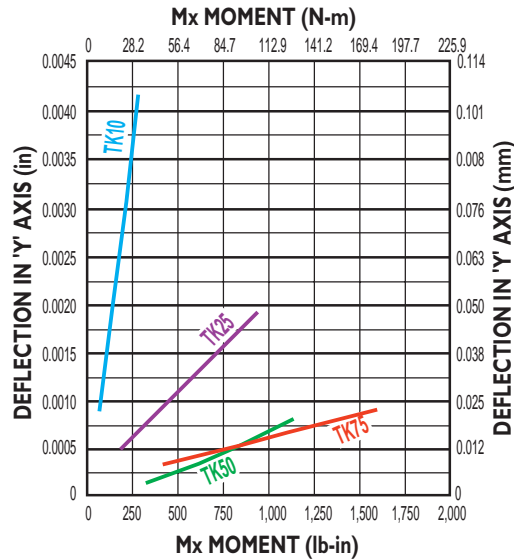
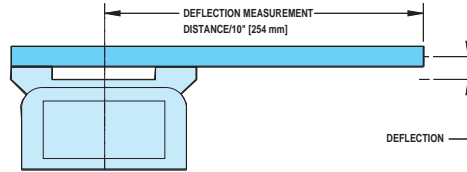

RODLESS

- TKB Series
- Load deflection
- Auxiliary carrier

AUXILIARY CARRIER: BENDING MOMENT AT 'D' DISTANCE

DYNAMIC BENDING MOMENT

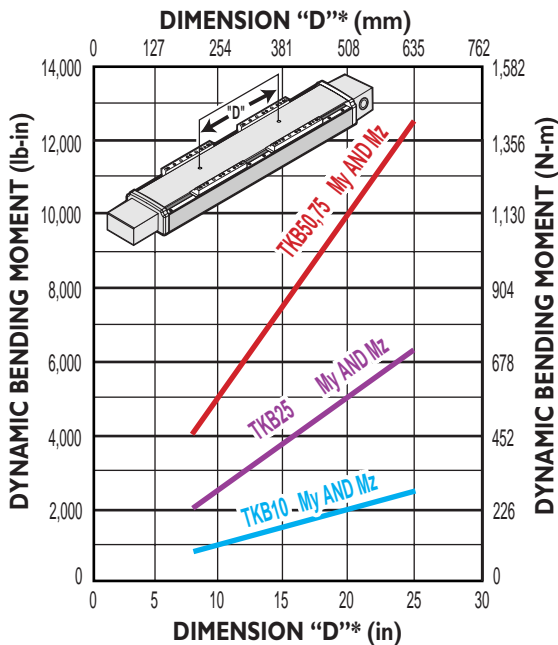

STATIC BENDING MOMENT

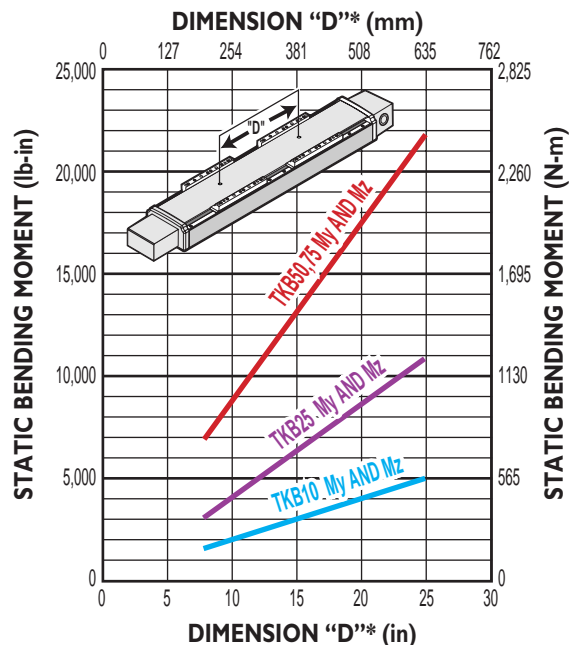

- Rates shown on charts were calculated with these assumptions:
- 1.) Coupling between carriers is rigid.
 - 2.) Load is equally distributed between carriers.
 - 3.) Coupling device applies no misalignment loads to carriers.

* Customer must specify Dimension "D" (Distance between carrier center lines) in configuration string.



Axi-dyne® TRUTrack™ TKB10 Series BELT SPECIFICATIONS

TKB10 BELT LOAD



RODLESS

- TKB10 Series**
- Belt load
 - Belt speed

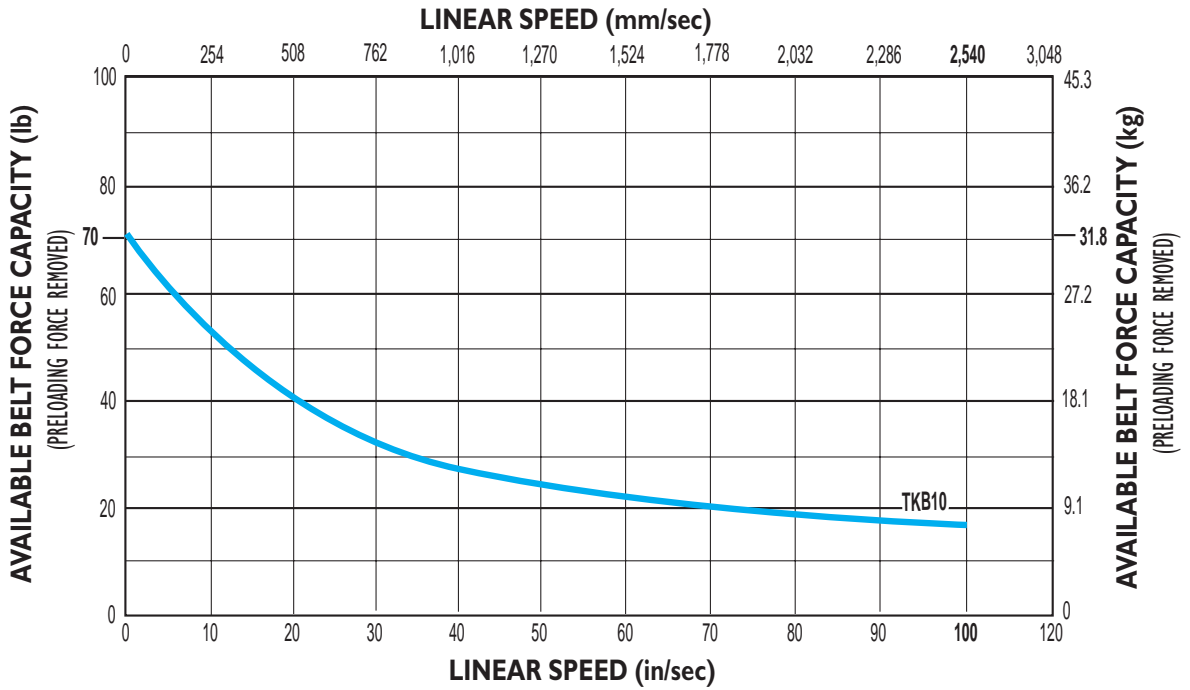

TKB10 BELT SPEED

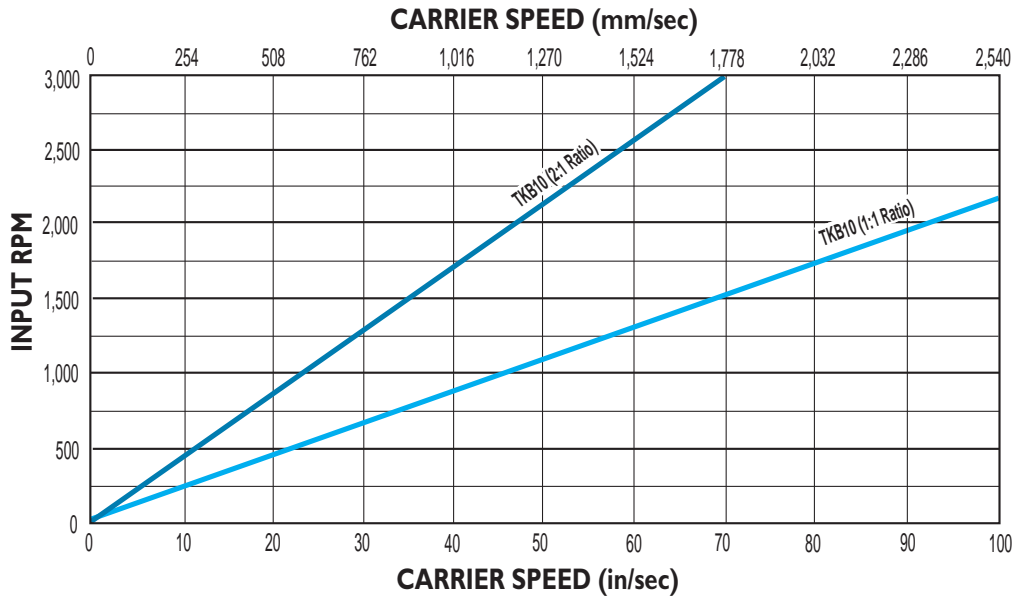

Axi-dyne® TRUTrack™ TKB10 Series

DIMENSIONS

TKB10 ACTUATOR AND OPTIONS

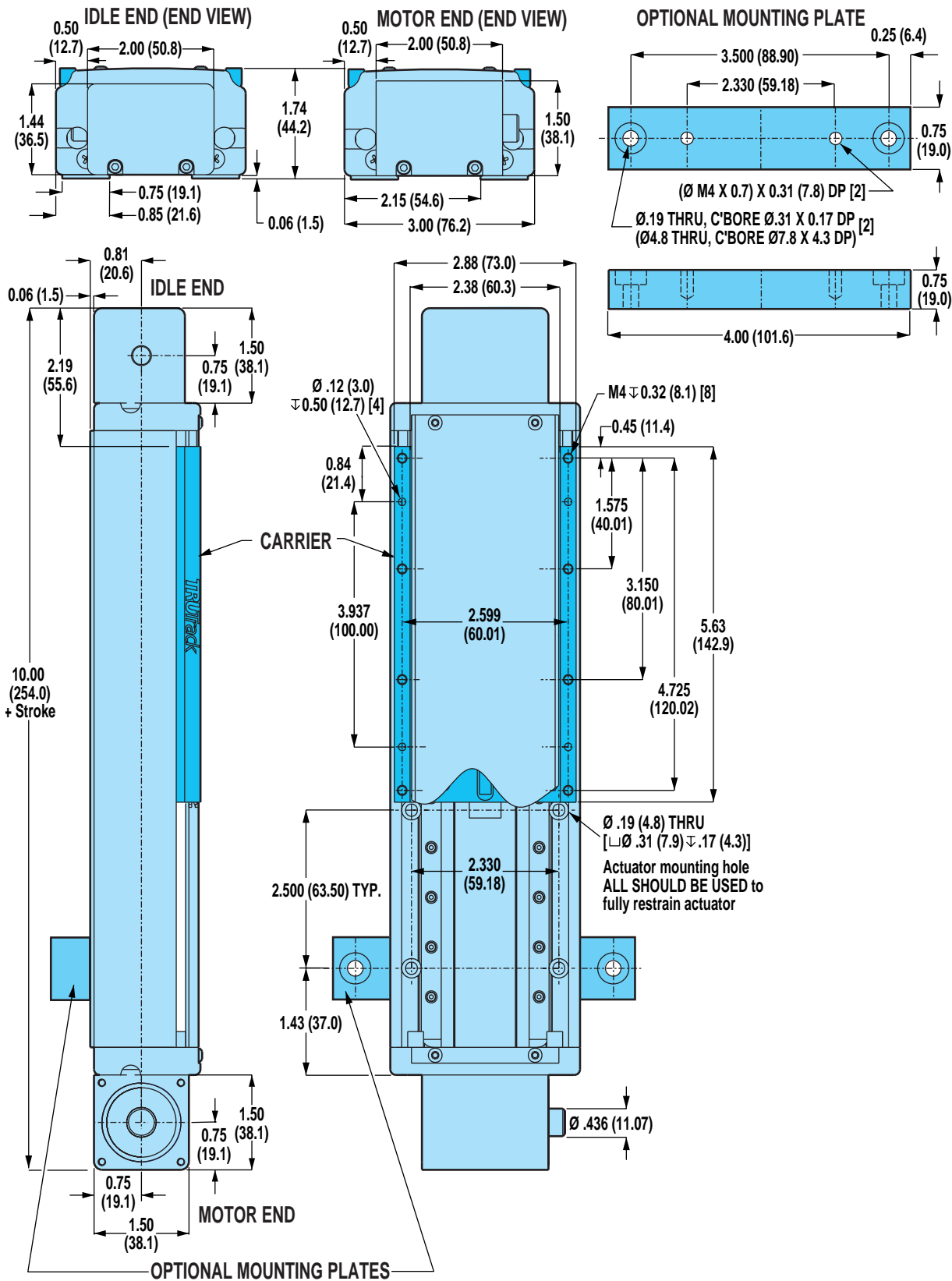

RODLESS

TKB10 Series

• Actuator and options dimensions

Unless otherwise noted, all dimensions shown are in inches (Dimensions in parenthesis are in millimeters)

Axi-dyne® TRUTrack™ TKB10 Series

DIMENSIONS

TKB10 DIRECT DRIVE MOTOR MOUNTING

For 23-frame MRV brushless and MRS stepper motors and 23-frame gearheads



RODLESS

- TKB10 Series**
- Direct drive mounting
 - Xy/Xj shaft option
 - Reduction drive mounting

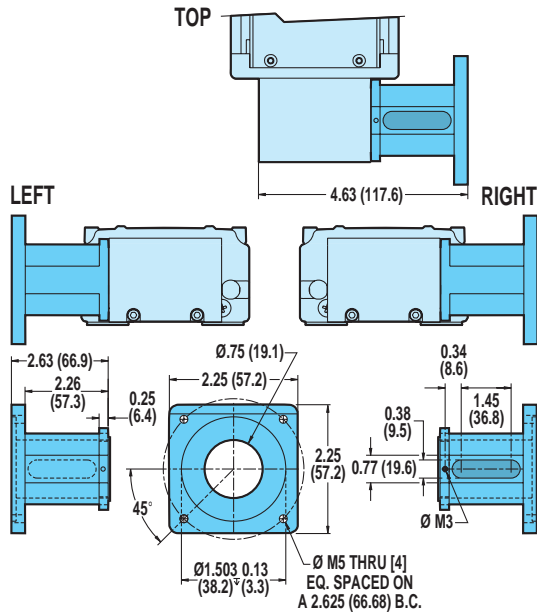

XY/XJ SHAFT OPTION

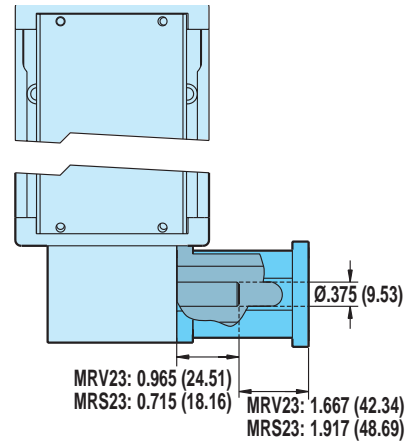

If a Tol-O-Matic motor is not specified in the configuration string, customer's motor must conform to the shaft dimensions shown for mounting compatibility. Please specify your motor type and frame size when ordering. See ordering pages F-33, G-23 or H-26 and refer to Customer Supplied Motor Mounting Specifications document 3600-4632.

TKB10 REDUCTION DRIVE MOTOR MOUNTING

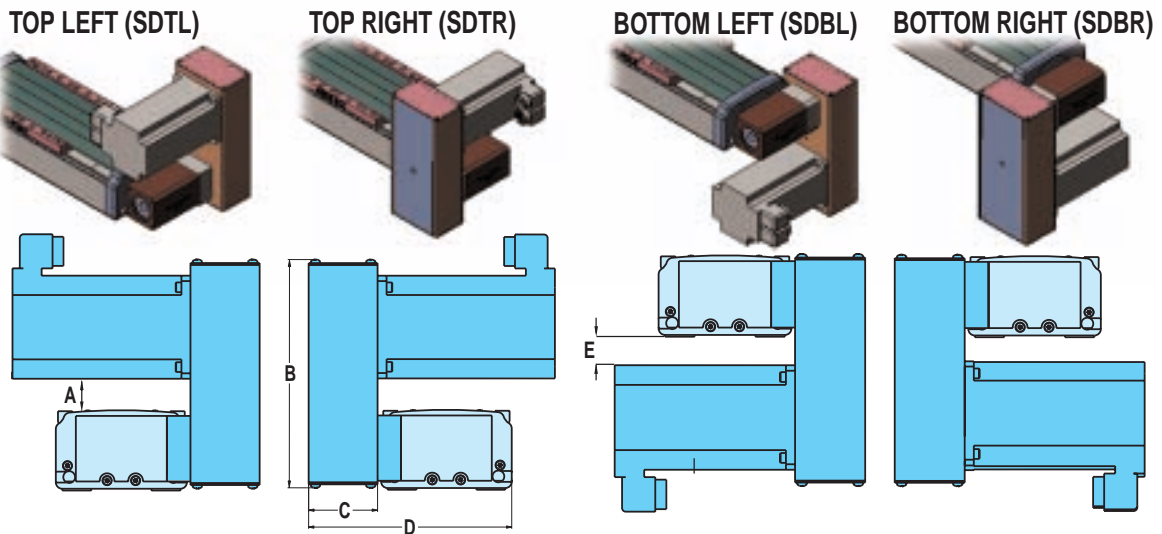

DIMENSIONS

	MOTORS	A		B		C		D		E	
		in.	mm	in.	mm	in.	mm	in.	mm	in.	mm
BRUSHLESS	MRV11	1.21	30.7	5.70	144.8	2.13	54.1	4.50	114.3	1.33	33.7
	MRV21, 22, 23, 24	0.86	21.9	5.70	144.8	2.13	54.1	4.50	114.3	0.98	24.9
STEPPER	MRS231, 232	0.86	21.9	5.70	144.8	2.13	54.1	4.50	114.3	0.98	24.9

SPECIFICATIONS

MOTORS	REDUCTION DRIVE WEIGHT				REDUCTION INERTIA AT MOTOR SHAFT			
	1:1 RATIO		2:1 RATIO		1:1 RATIO		2:1 RATIO	
	lb	kg	lb	kg	lb-in ²	kg-m ² x 10 ⁴	lb-in ²	kg-m ² x 10 ⁴
MRV11	1.80	0.82	1.80	0.82	0.025	7.313	0.057	16.560
MRV21, 22, 23, 24	1.80	0.82	1.80	0.82	0.056	16.380	0.088	25.667
MRS231, 232	1.80	0.82	1.80	0.82	0.023	6.728	0.055	16.014

REDUCTION EFFICIENCY: 0.95

Axi-dyne® TRUTrack™ TKB25 Series

BELT SPECIFICATIONS



TKB25 BELT LOAD

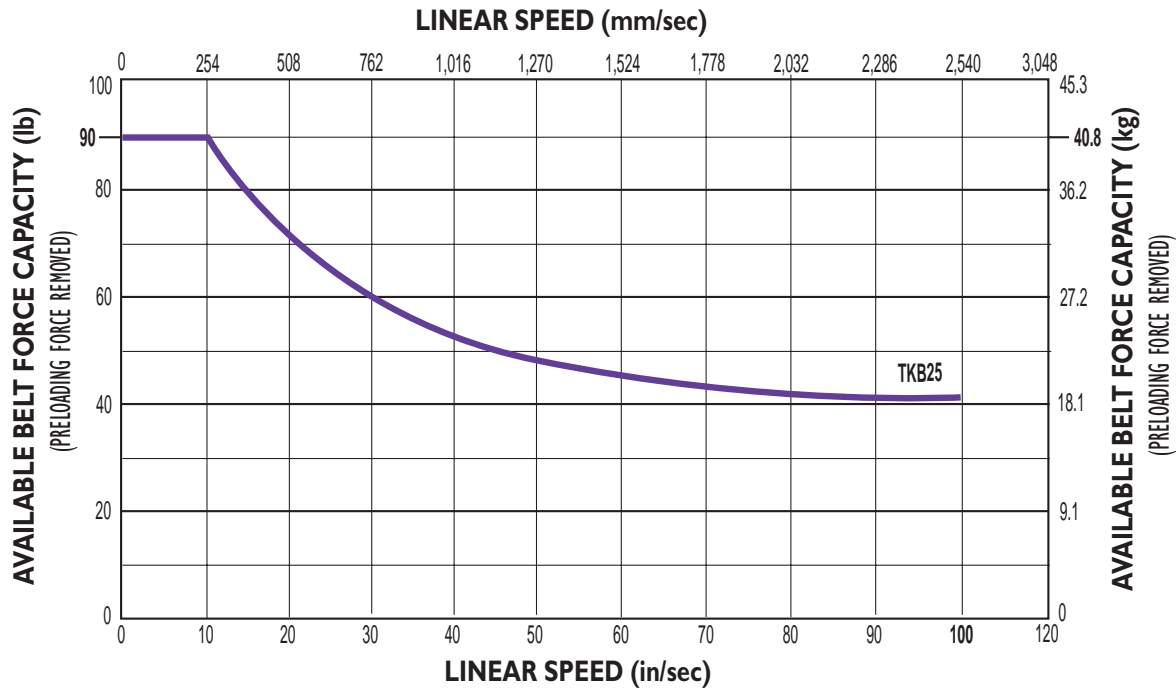

RODLESS

- TKB25 Series**
- Belt load
 - Belt speed

TKB25 BELT SPEED

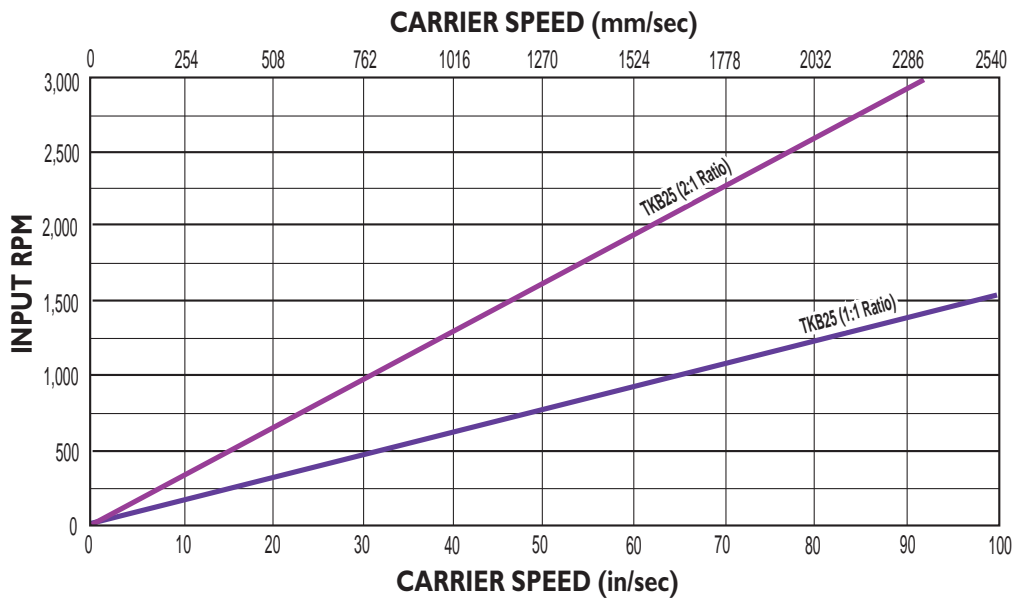

Axi dyne® TRUTrack™ TKB25 Series

DIMENSIONS

TKB25 ACTUATOR AND OPTIONS



RODLESS

TKB10 Series
• Actuator and option dimensions

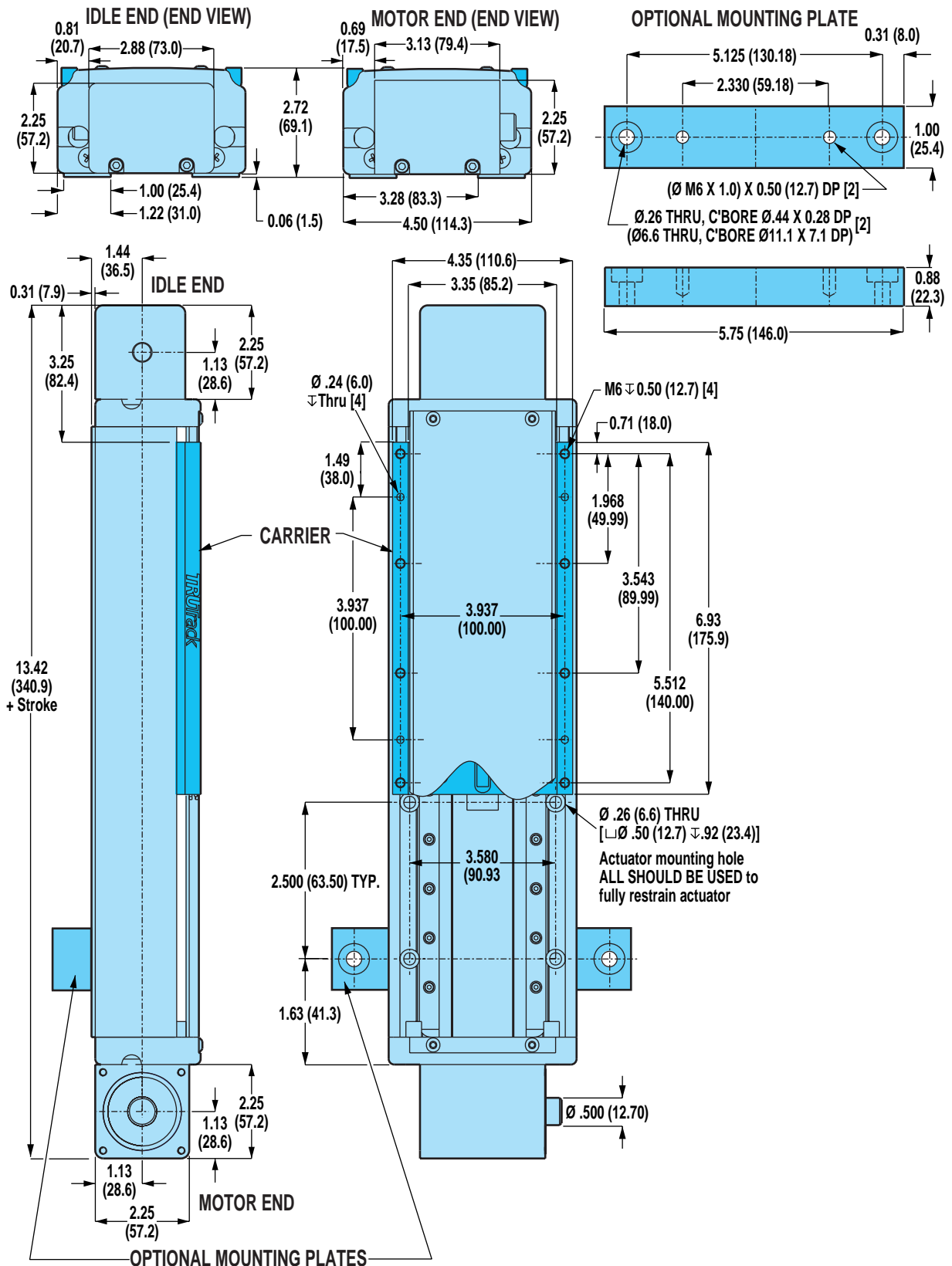

Unless otherwise noted, all dimensions shown are in inches (Dimensions in parenthesis are in millimeters)

Axi-dyne® TRUTrack™ TKB25 Series

DIMENSIONS

TKB25 DIRECT DRIVE MOUNTING MOTOR ADAPTER

For 23-frame MRV brushless motors and gearheads

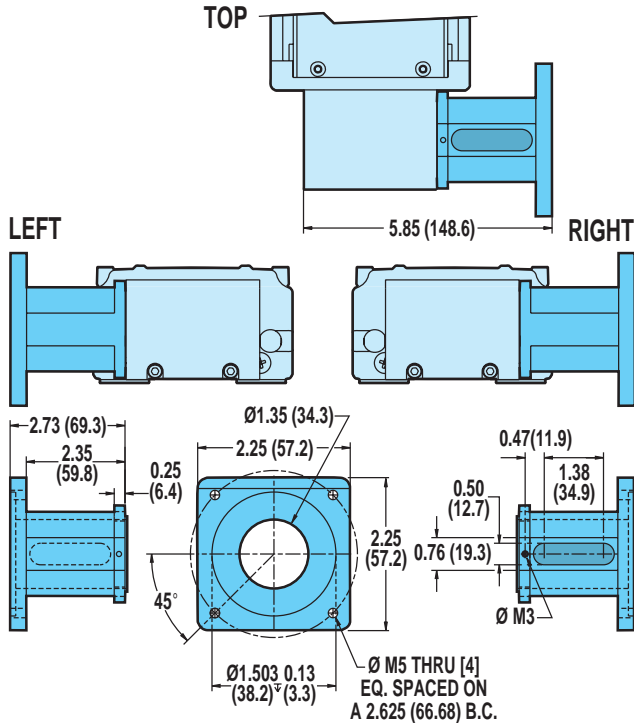

For 34-frame MRV brushless and MRS stepper motors and 34-frame gearheads.

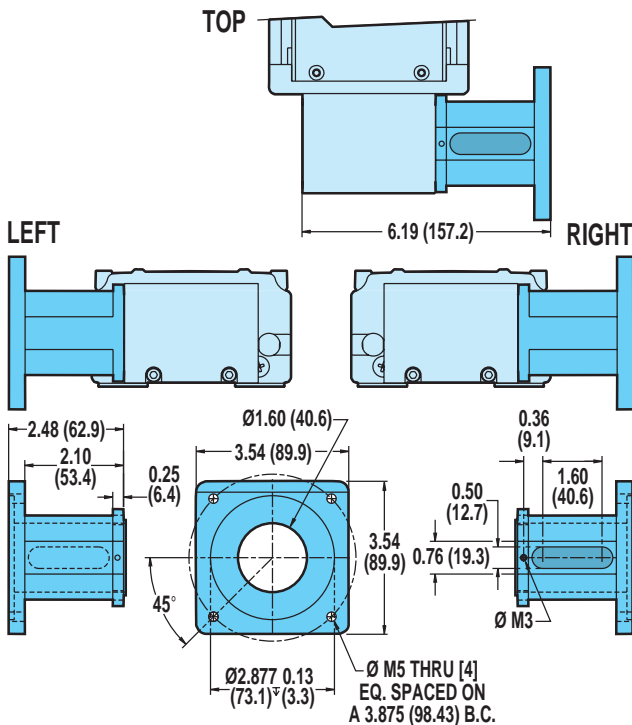

XY/XJ SHAFT OPTION

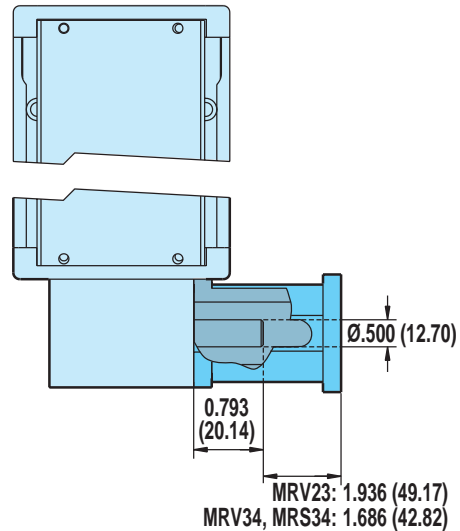

RODLESS

TKB25 Series
• Direct drive motor and gearhead mounting

⚠ If a Tol-O-Matic motor is not specified in the configuration string, customer's motor must conform to the shaft dimensions shown for mounting compatibility. Please specify your motor type and frame size when ordering. See ordering pages F-33, G-23 or H-26 and refer to Customer Supplied Motor Mounting Specifications document 3600-4632.

Axi-dyne® TRUTrack™ TKB25 Series

DIMENSIONS

TKB25 REDUCTION DRIVE MOTOR MOUNTING

TOP LEFT (SDTL)

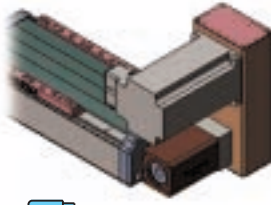

TOP RIGHT (SDTR)

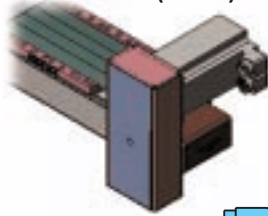

BOTTOM LEFT (SDBL)

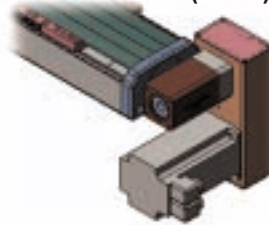

BOTTOM RIGHT (SDBR)

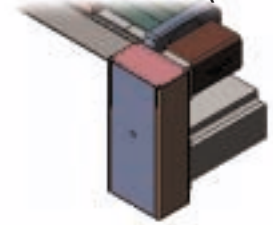

RODLESS

TKB25 Series
• Reduction drive motor mounting

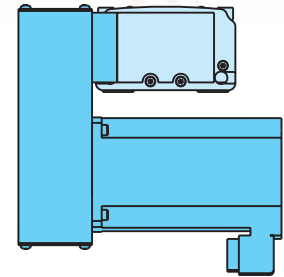
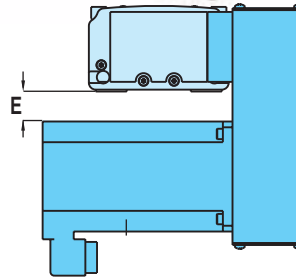
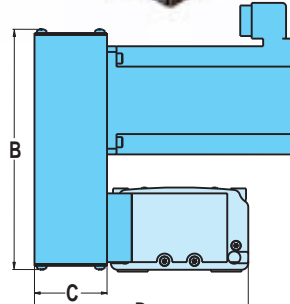
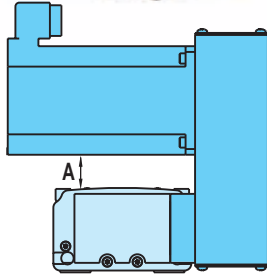

DIMENSIONS

	MOTORS	A		B		C		D		E	
		in.	mm	in.	mm	in.	mm	in.	mm	in.	mm
BRUSHLESS	MRV21, 22, 23, 24	1.77	44.9	7.02	178.3	2.13	54.1	5.67	144.1	1.61	40.8
	MRV31, 32, 33	1.12	28.5	7.79	197.9	2.38	60.5	5.92	150.4	0.96	24.4
STEPPER	MRS341, 342, 343	1.20	30.5	7.79	197.9	2.38	60.5	5.92	150.4	1.04	26.4

SPECIFICATIONS

MOTORS	REDUCTION DRIVE WEIGHT				REDUCTION INERTIA AT MOTOR SHAFT			
	1:1 RATIO		2:1 RATIO		1:1 RATIO		2:1 RATIO	
	lb	kg	lb	kg	lb-in ²	kg-m ² x 10 ⁴	lb-in ²	kg-m ² x 10 ⁴
MRV21, 22, 23, 24	2.55	1.16	2.78	1.26	0.036	10.530	0.103	30.054
MRV31, 32, 33	2.80	1.27	3.03	1.37	0.036	10.530	0.103	30.054
MRS341, 342, 343	2.22	1.00	2.45	1.11	0.051	14.918	0.118	34.442

REDUCTION EFFICIENCY: 0.95

Axi-dyne[®] TRUTrack™ TKB50 Series

BELT SPECIFICATIONS



TKB50 BELT LOAD

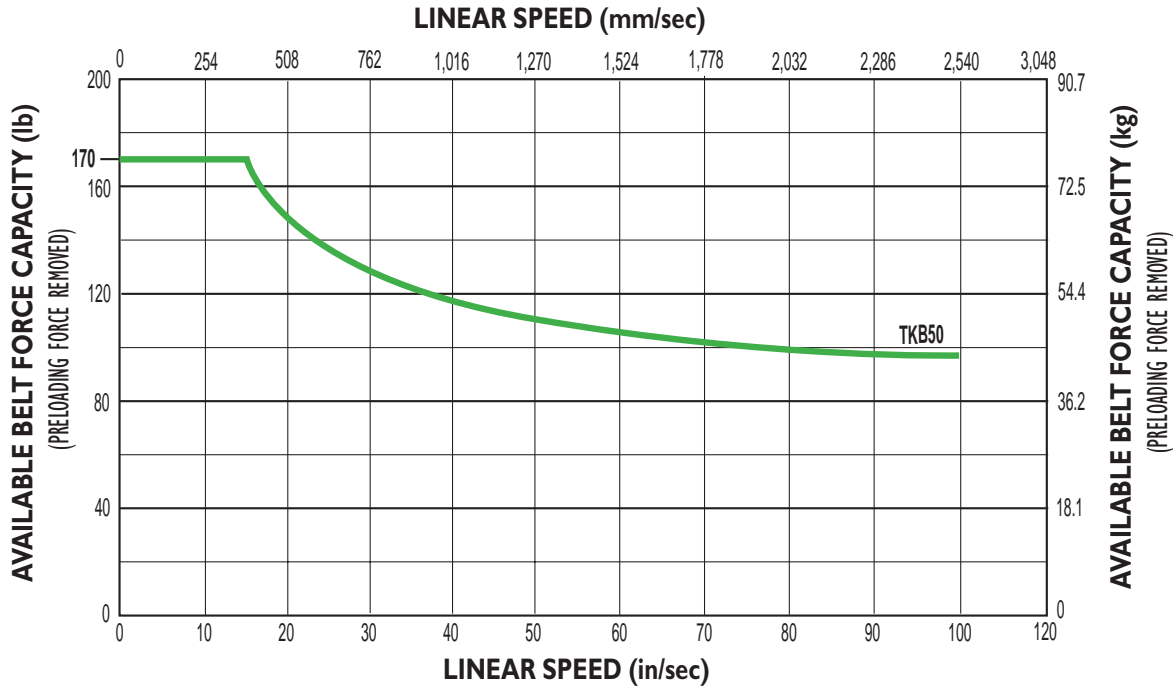

RODLESS

TKB50 Series

- Belt load
- Belt Speed

TKB50 BELT SPEED

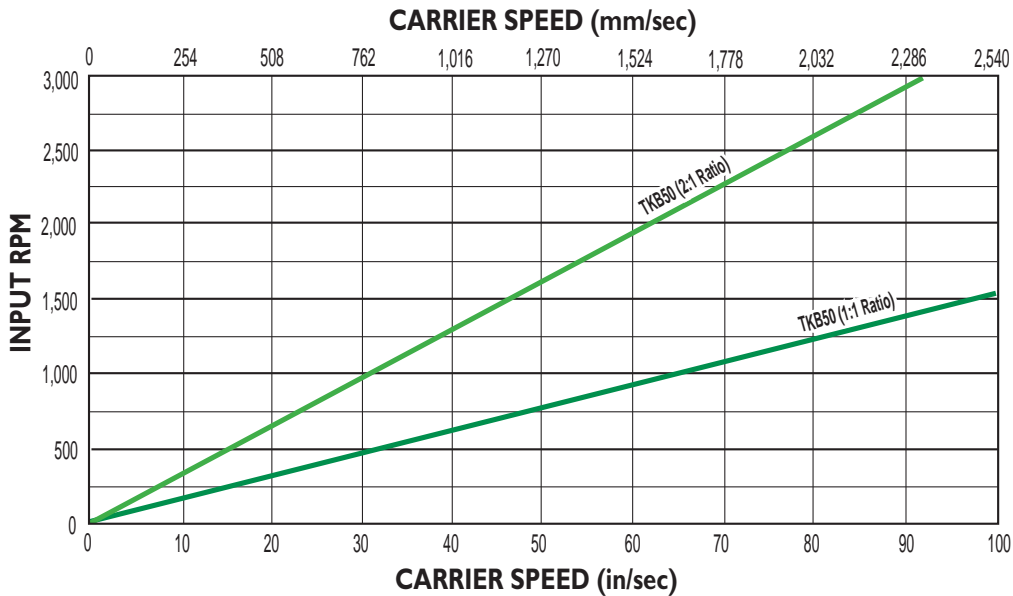

Axi-dyne® TRUTrack™ TKB50 Series

DIMENSIONS

TKB50 ACTUATOR AND OPTIONS



RODLESS

TKB50 Series

- Actuator and options dimensions

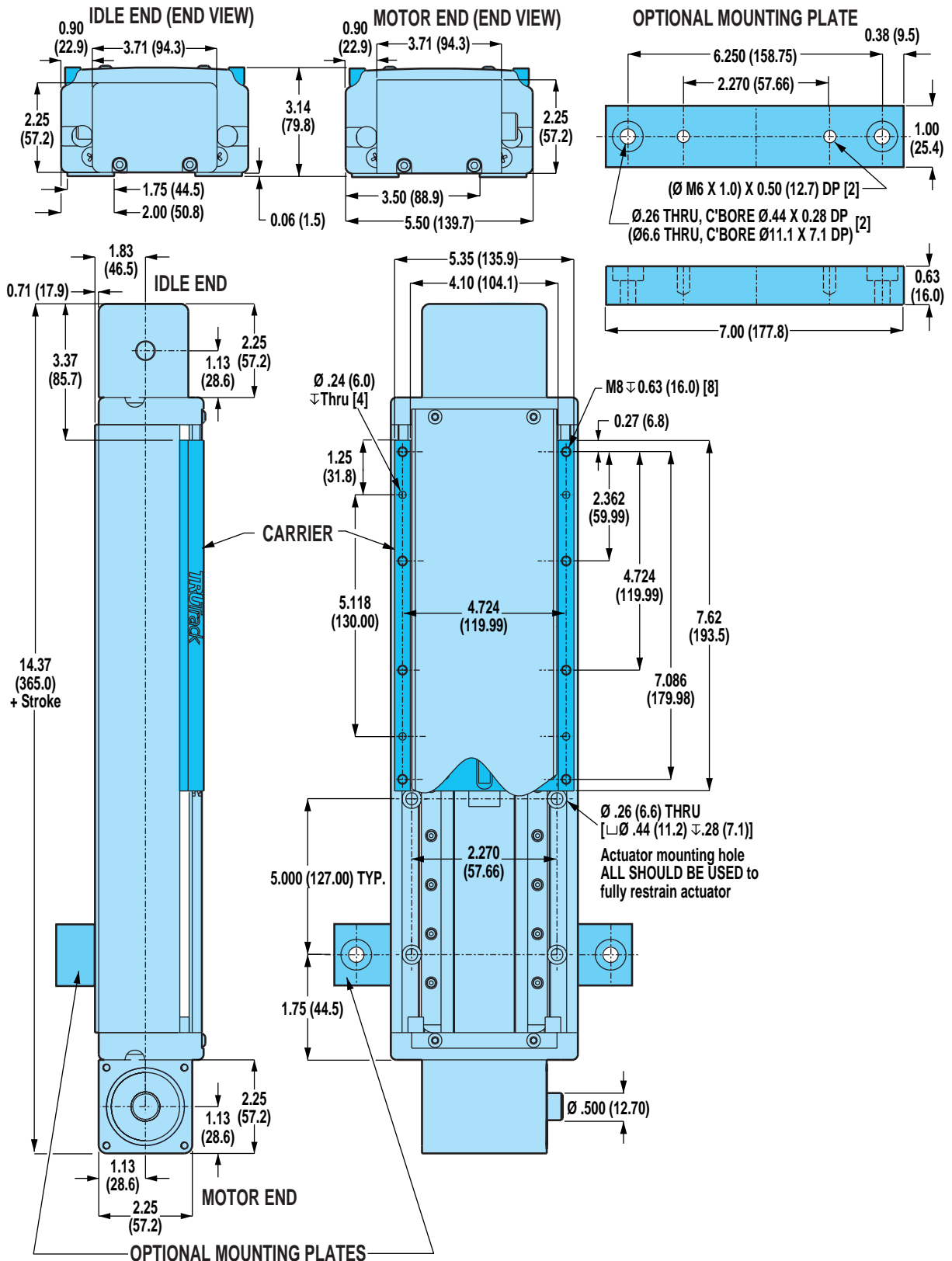

Unless otherwise noted, all dimensions shown are in inches (Dimensions in parenthesis are in millimeters)

Axi-dyne® TRUTrack™ TKB50 Series

DIMENSIONS

TKB50 DIRECT DRIVE MOUNTING MOTOR ADAPTER

For 23-frame MRV brushless motors and gearheads

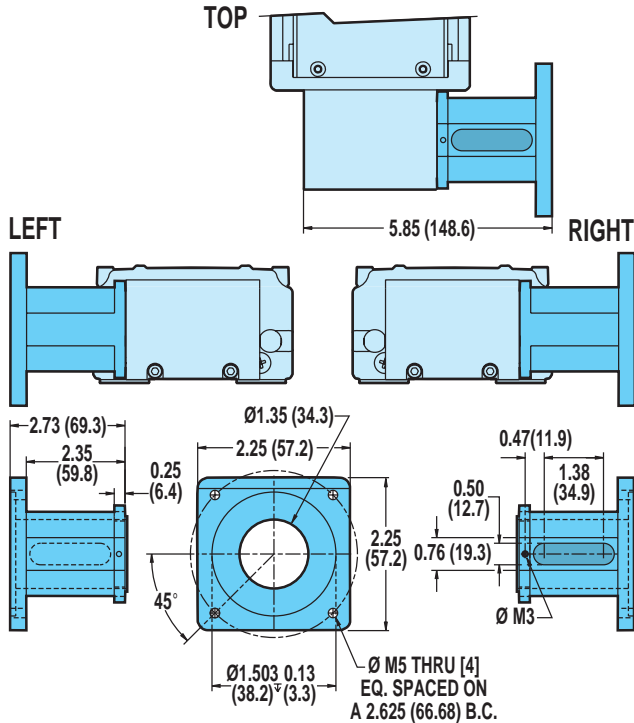

For 34-frame MRV brushless and MRS stepper motors and 34-frame gearheads.

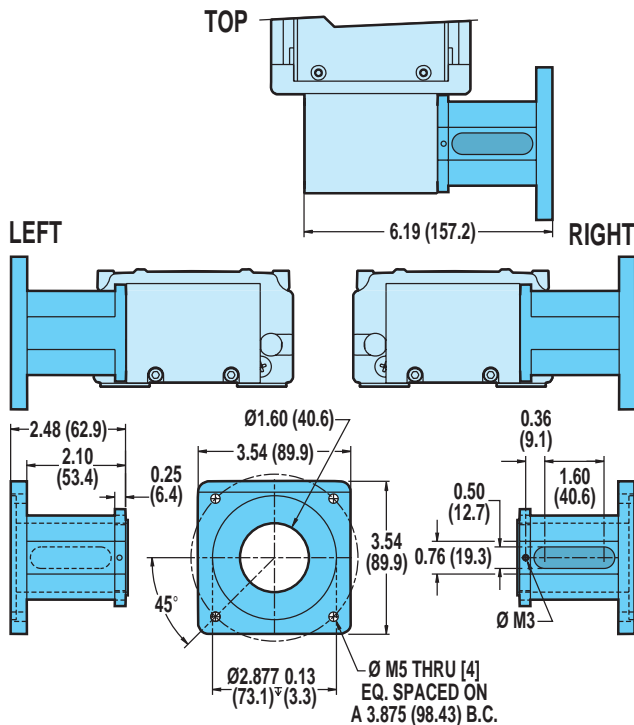

XY/XJ SHAFT OPTION

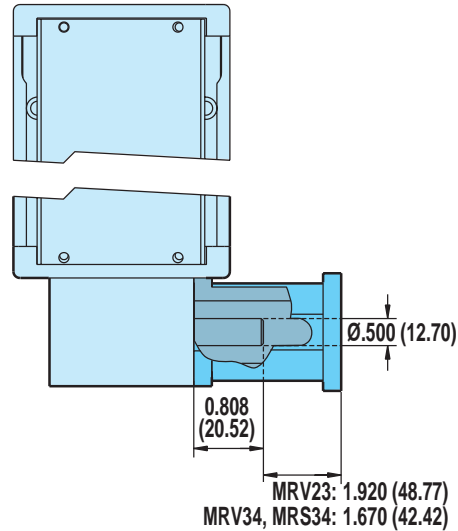

RODLESS

- TKB50 Series**
- Direct drive motor mounting
 - Xy/Xj shaft option

! If a Tol-O-Matic motor is not specified in the configuration string, customer's motor must conform to the shaft dimensions shown for mounting compatibility. Please specify your motor type and frame size when ordering. See ordering pages F-33, G-23 or H-26 and refer to Customer Supplied Motor Mounting Specifications document 3600-4632.

Axi-dyne® TRUTrack™ TKB50 Series

DIMENSIONS

TKB50 REDUCTION DRIVE MOTOR MOUNTING

TOP LEFT (SDTL)

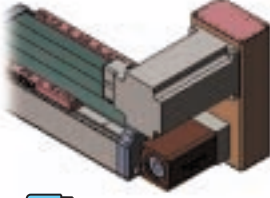

TOP RIGHT (SDTR)

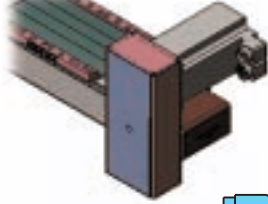

BOTTOM LEFT (SDBL)

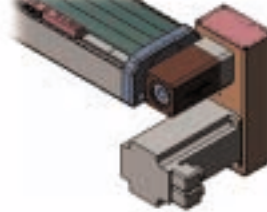

BOTTOM RIGHT (SDBR)



RODLESS

TKB50 Series
• Reduction drive motor mounting

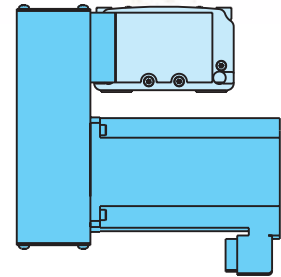
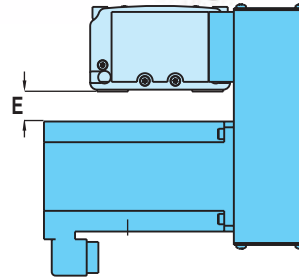
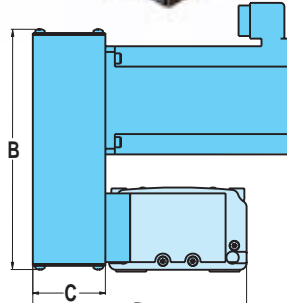
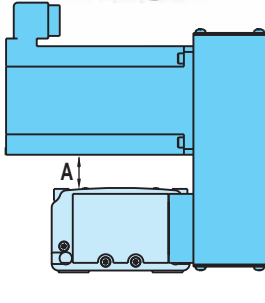

DIMENSIONS

	MOTORS	A		B		C		D		E	
		in.	mm	in.	mm	in.	mm	in.	mm	in.	mm
		BRUSHLESS	MRV21, 22, 23, 24	2.50	63.4	8.34	211.8	2.13	54.1	6.48	164.6
BRUSHLESS	MRV31, 32, 33	1.85	47.0	8.98	228.1	2.38	60.5	6.73	170.9	1.31	33.3
STEPPER	MRS341, 342, 343	1.93	49.0	8.98	228.1	2.38	60.5	6.73	170.9	1.39	35.3

SPECIFICATIONS

MOTORS	REDUCTION DRIVE WEIGHT				REDUCTION INERTIA AT MOTOR SHAFT			
	1:1 RATIO		2:1 RATIO		1:1 RATIO		2:1 RATIO	
	lb	kg	lb	kg	lb-in ²	kg-m ² x 10 ⁴	lb-in ²	kg-m ² x 10 ⁴
MRV21, 22, 23, 24	2.87	1.30	3.10	1.40	0.036	10.530	0.103	30.054
MRV31, 32, 33	3.44	1.56	3.60	1.63	0.036	10.530	0.103	30.054
MRS341, 342, 343	3.20	1.45	3.40	1.54	0.051	14.918	0.118	34.442

REDUCTION EFFICIENCY: 0.95

Axi-dyne® TRUTrack™ TKB75 Series

BELT SPECIFICATIONS



TKB75 BELT LOAD

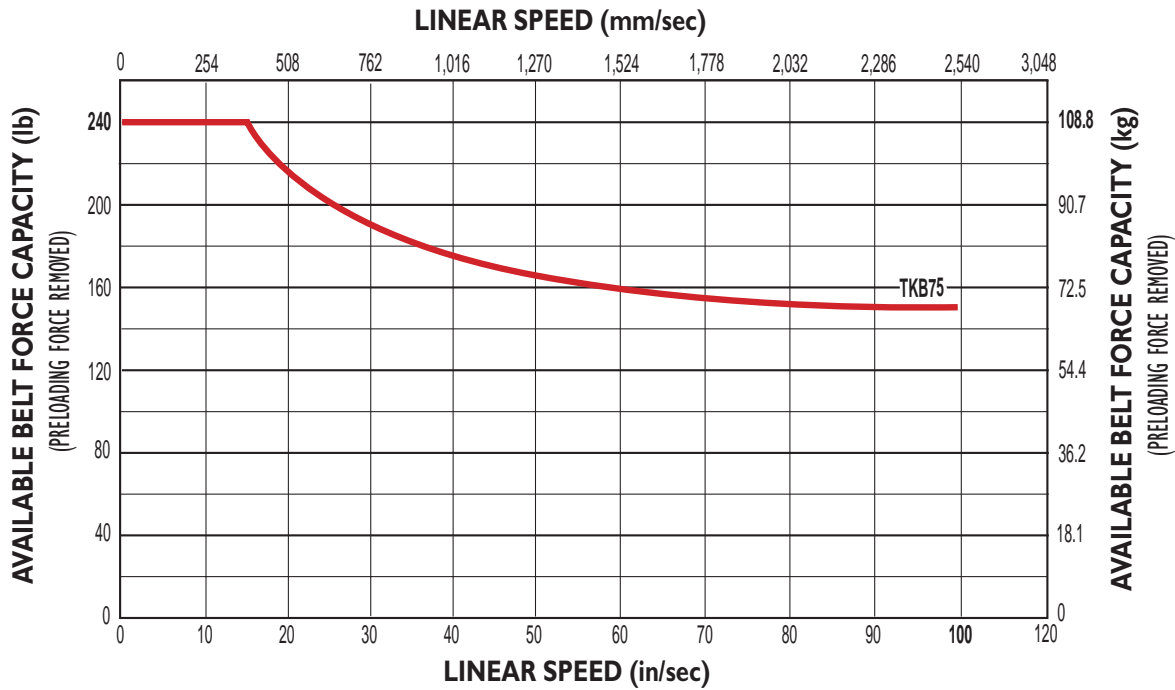

RODLESS

- TKB75 Series**
- Belt load
 - Belt speed

TKB75 BELT SPEED

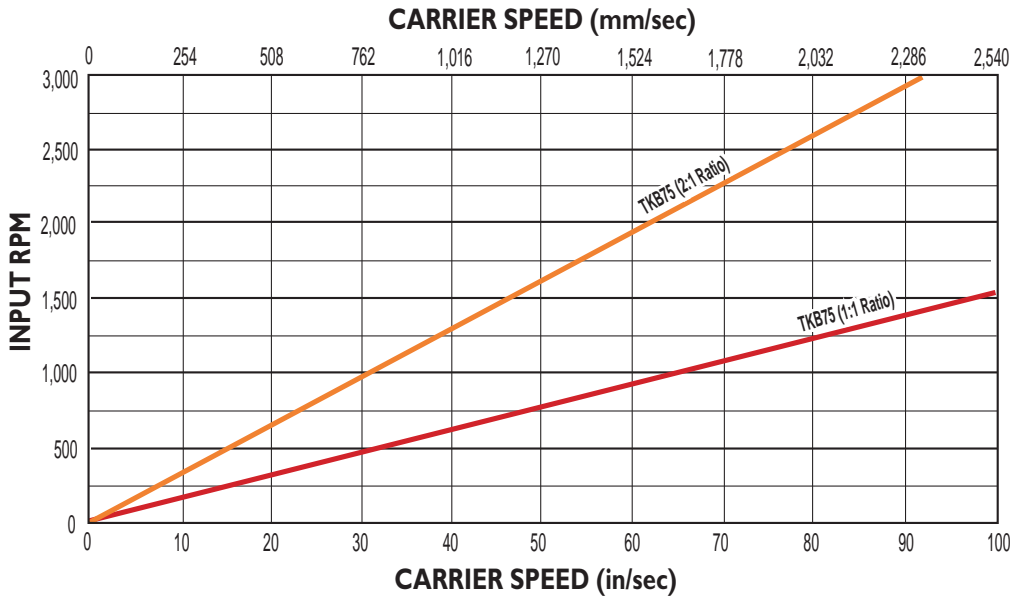

Axi dyne® TRUTrack™ TKB75 Series

DIMENSIONS

TKB75 ACTUATOR AND OPTIONS



RODLESS

TKB75 Series

- Actuator and options dimensions

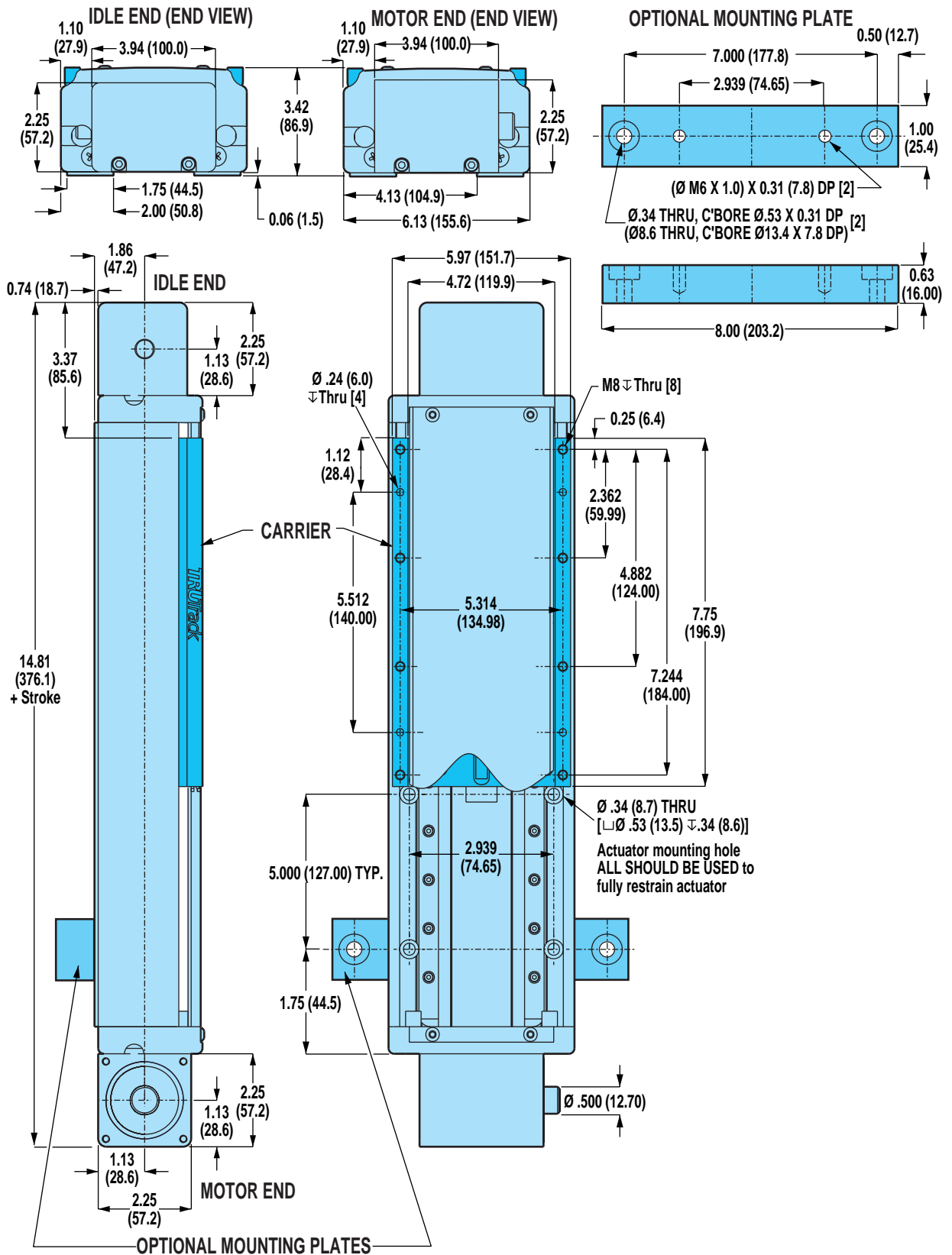

Unless otherwise noted, all dimensions shown are in inches (Dimensions in parenthesis are in millimeters)

Axi-dyne® TRUTrack™ TKB75 Series

DIMENSIONS

TKB75 DIRECT DRIVE MOTOR MOUNTING

For 34-frame MRV brushless and MRS stepper motors and 34-frame gearheads

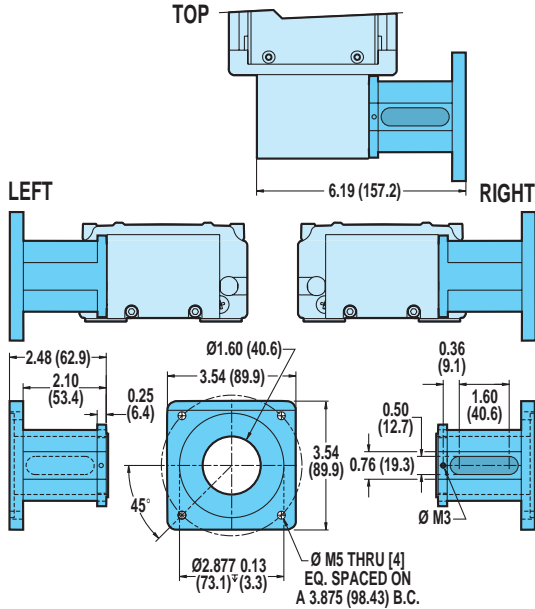

XY/XJ SHAFT OPTION

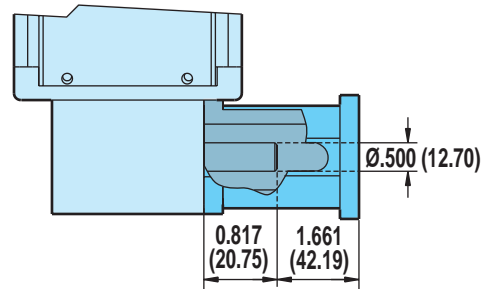

RODLESS

TKB75 Series

- Direct drive motor mounting dimensions
- Reduction drive motor mounting dimensions
- Xy/Xj motor mounting option



If a Tol-O-Matic motor is not specified in the configuration string, customer's motor must conform to the shaft dimensions shown for mounting compatibility. Please specify your motor type and frame size when ordering. See ordering pages F-33, G-23 or H-26 and refer to Customer Supplied Motor Mounting Specifications document 3600-4632.

TKB75 REDUCTION DRIVE MOTOR MOUNTING

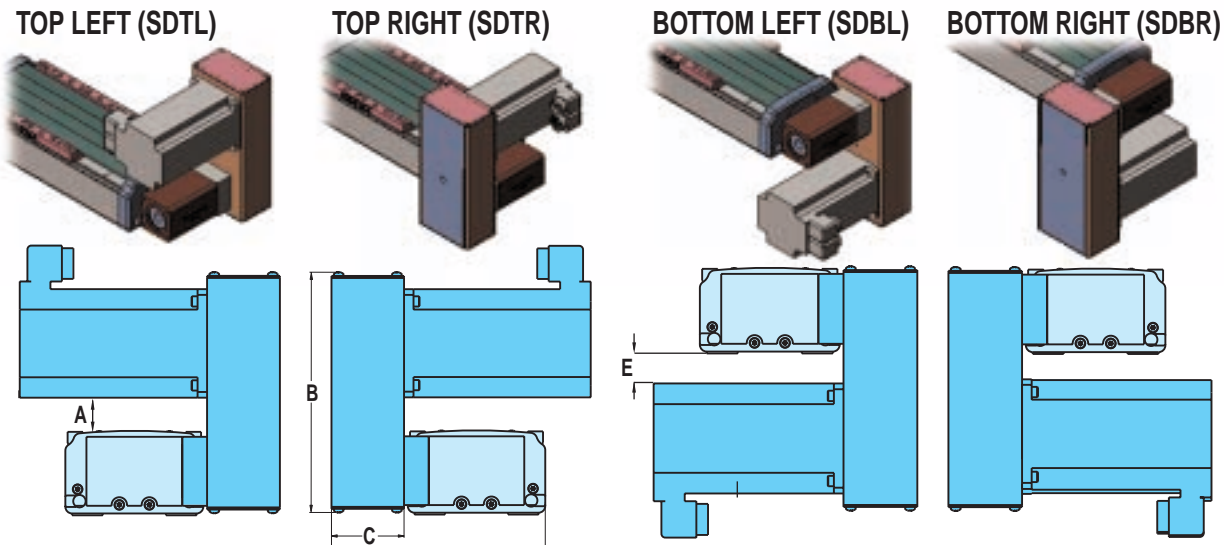

DIMENSIONS

	MOTORS	A		B		C		D		E	
		in.	mm	in.	mm	in.	mm	in.	mm	in.	mm
BRUSHLESS	MRV31, 32, 33	1.60	40.7	8.98	228.1	2.38	60.5	7.00	177.9	1.28	32.5
	MRS341, 342, 343	1.68	42.7	8.98	228.1	2.38	60.5	7.00	177.9	1.36	34.6

SPECIFICATIONS

MOTORS	REDUCTION DRIVE WEIGHT				REDUCTION INERTIA AT MOTOR SHAFT			
	1:1 RATIO		2:1 RATIO		1:1 RATIO		2:1 RATIO	
	lb	kg	lb	kg	lb-in ²	kg-m ² x 10 ⁴	lb-in ²	kg-m ² x 10 ⁴
MRV31, 32, 33	3.44	1.56	3.60	1.63	0.036	10.530	0.103	30.054
MRS341, 342, 343	3.20	1.45	3.40	1.54	0.051	14.918	0.118	34.442

REDUCTION EFFICIENCY: 0.95

Axi *dyne*® TRUTrack™ TKB Belt Drives

ORDERING

BASE MODEL SPECIFICATIONS

TKB 50 SK48 SDBR2

OPTIONS SPECIFICATIONS

DC18 KT2 BE2 LU MP4

MODEL TYPE

TKB TKB Series TruTrack Belt Drive

PAYLOAD LIMITS

10 100 lbs
25 250 lbs
50 500 lbs
75 750 lbs

STROKE LENGTH

SK Stroke, then enter desired stroke length in decimal inches

MODEL	MAX STROKE* (in)
TKB ALL SIZES	96

*Actuator cover has maximum stroke of 48 inches

MOTOR MOUNTING / REDUCTIONS

(must choose one)

SDL Direct Drive / left
SDR Direct Drive / right

⚠ **A motor size and code must be selected when specifying a 1:1 or 2:1 reduction. Reference the ordering pages in sections F, G and H for the motor types and selections.**

SDTL1 1:1 Reduction Drive / top left
SDTR1 1:1 Reduction Drive / top right
SDBL1 1:1 Reduction Drive / bottom left
SDBR1 1:1 Reduction Drive / bottom right
SDTL2 2:1 Reduction Drive / top left
SDTR2 2:1 Reduction Drive / top right
SDBL2 2:1 Reduction Drive / bottom left
SDBR2 2:1 Reduction Drive / bottom right

AUXILIARY CARRIER

DC_ Auxiliary Carrier, then center-to-center spacing desired in decimal inches. (Center-to-Center spacing will add to overall dead length and will not subtract from the stroke length)

SWITCHES

RT_ Reed Switch (Form A) with 5-meter lead, and quantity desired
BT_ Reed Switch (Form C) with 5-meter lead, and quantity desired
KT_ Hall-effect Sinking Switch with 5-meter lead, and quantity desired
TT_ Hall-effect Sourcing Switch with 5-meter lead, and quantity desired
SP* Sensor Package

*Includes: Two Form C reed switches w/5-meter leads, mounted 1" from end-of-stroke and one Hall-effect sinking switch w/5-meter lead, mounted 2" from end-of-stroke on motor end.

BELLOWS

BE2 Bellows option (increases the dead length of the actuator, see page C-87)

SPECIAL LUBRICATION

LU Low dust generating grease

MOUNTING PLATES

MP_ Mounting Plates plus quantity desired

TO ORDER MOTORS/CONTROLS/INTERFACES

-  **BRUSHLESS SERVO (SEE PAGE F-33)**
-  **MICROSTEPPING (SEE PAGE G-23)**
-  **BRUSHED DC (SEE PAGE H-26)**



Not all codes listed are compatible with all options.

Use the Tol-O-Motion™ Sizing Software to determine available options and accessories based on your application requirements.

FIELD RETROFIT KITS

ITEM	TKB10	TKB25	TKB50	TKB75
Mounting Plates	0601-9803	0602-9803	0603-9803	0604-9803



RODLESS

TKB Series
• Ordering

Axi-dyne® BCS/MCS Screw Drives

OVERVIEW



APPLICATION BENEFITS

- Moderate load carrying capabilities at an economical price
- Easily retrofittable and interchangeable
- Adjustable carrier and self-lubricating bearings for easy maintenance

GUIDANCE SYSTEM



A patented* adjustable carrier bracket transmits the load to the cylinder body, instead of the screw for true tracking, superior load support and controlled minimum friction load. Two self-lubricating Delrin bearing rods, pass force directly to the cylinder tube. Patented** Band Retention system uses a T-shaped elastomer strip bonded to a stainless steel band, inserted directly into the body housing forming a tight metal-to-metal seal for clean operation.

*U.S. Patent No. 4724744

**U.S. Patent No. 4545290

STANDARD MOUNTING



Mounting holes are provided on the underside of the cylinder heads. To mount, transfer the location of holes to the receiving surface. Drill mounting holes 1/32" larger than diameter of the mounting screws and attach securely with appropriate screws.

ACTUATOR/MOTOR FACTORS

- Actuator's operating temperature range (40-130° F, 4-54° C) should take into consideration heat generated by the motor and drive, linear velocity and work cycle time.
- For large frame motors or small actuators, cantilevered motors need to be supported, if subjected to continuous rapid reversing duty and/or under dynamic conditions.

AVAILABLE OPTIONS



Tube Supports: Provide intermediate support of actuator body at the recommended intervals. They are designed to fit into the dove-tailed grooves running the entire length of the cylinder tube.



Mounting Plates: Provide clearance height for motors and motor mounts when mounting an actuator on a flush surface. Mounted to the tapped holes in cylinder heads, they provide the means for top mounting access. Kits include plates and mounting screws.



Floating Mount Bracket: Compensates for non-parallelism between the actuator and an external support/guidance system. These mounts should be used on independently-guided loads to eliminate actuator binding. Use of the Float Mount, adds 0.014" (0.36 mm) to the backlash.



Auxiliary Carrier: Increases rigidity, load-carrying capacity and bending moments



Motor Mounting and Gearhead Reduction:

In-line Motor Mounting—This motor mounting option uses a spacer and coupler to join the motor to the actuator shaft.



Reverse-parallel Motor Mounting—These factory assembled configurations allow offset mounting of the motor to either side of, or below the actuator. Available in 1:1 or 2:1 drive ratios, they offer quiet, zero-backlash coupling of the motor to the actuator screw shaft.



Gearhead Reduction—Gearheads are available for applications requiring reduction for inertia matching or higher torque at lower speeds. High efficiency, single stage, true planetary gearheads are available in 5.5:1 and 10:1 ratios for reduction solutions with most Tol-O-Matic NEMA 23 and 34 face motors. See page F-10.



Switches: Reed, dc Hall-effect and ac TRIAC. See section I.

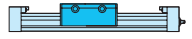

RODLESS

BCS/MCS Series

- Application benefits
- Guidance system
- Standard mounting
- Actuator/motor factors
- Available options

Axi-dyne® BCS/MCS Screw Drives

ACME SCREW/NUT COMBINATIONS

ACME SCREW CRITICAL SPEED CAPACITIES

CRITICAL SPEED WITH ENGLISH ACME SCREW

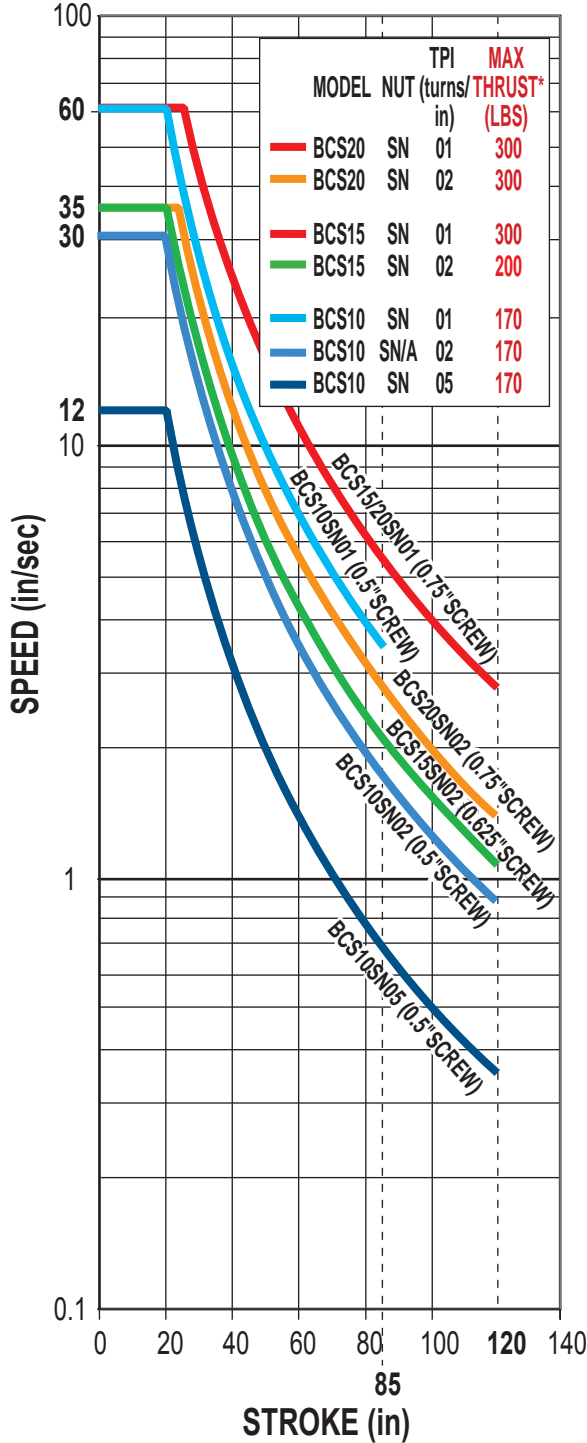

CRITICAL SPEED WITH METRIC ACME SCREW

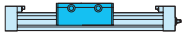
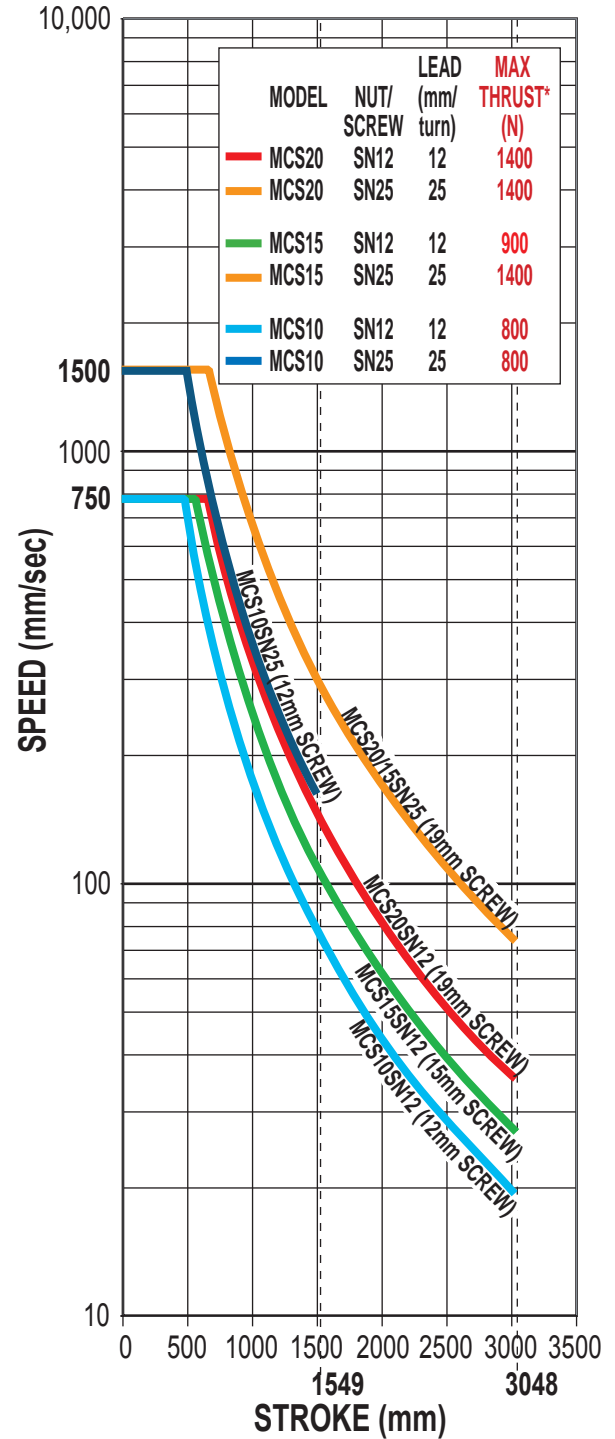

RODLESS

BCS/MCS Series

- Acme critical speed capacities



*Maximum thrust is the maximum continuous dynamic thrust subject to Thrust x Velocity limitation.

Dotted lines represent maximum stroke for screw selections.

For Screw PV limits, refer to the individual charts located in the technical section for each actuator body size.

Axi-dyne® BCS/MCS Screw Drives

BALL SCREW/NUT COMBINATIONS

BALL SCREW CRITICAL SPEED CAPACITIES

CRITICAL SPEED WITH ENGLISH BALL SCREW

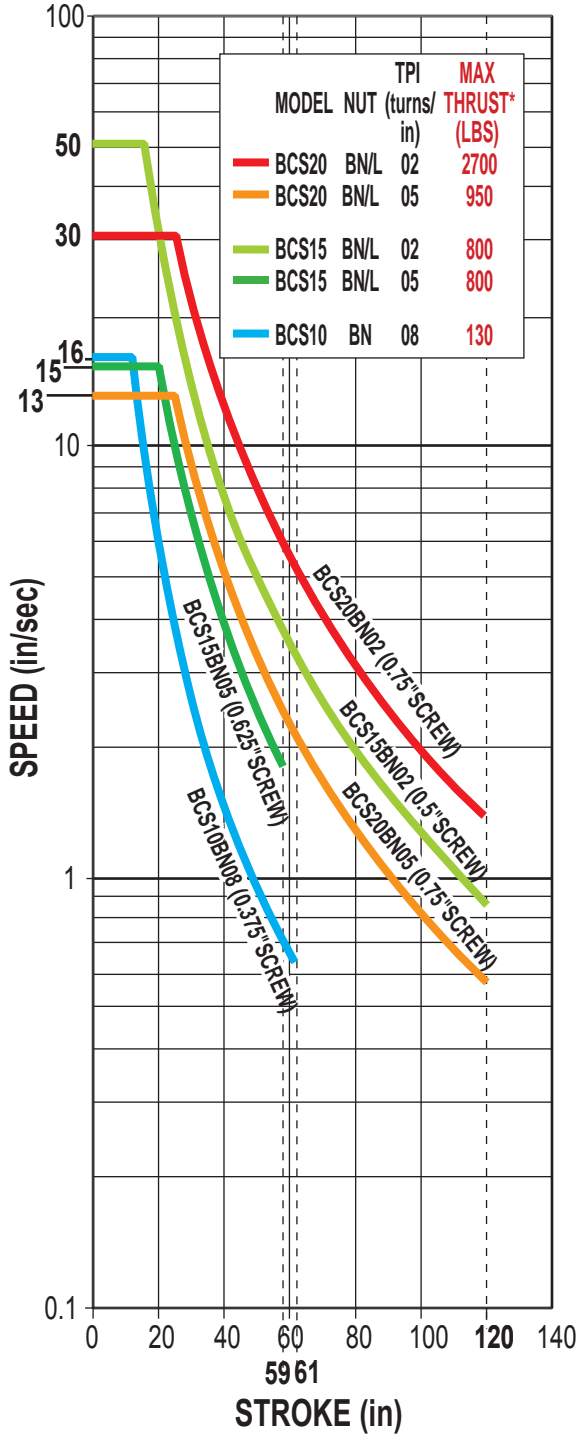

CRITICAL SPEED WITH METRIC BALL SCREW

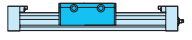
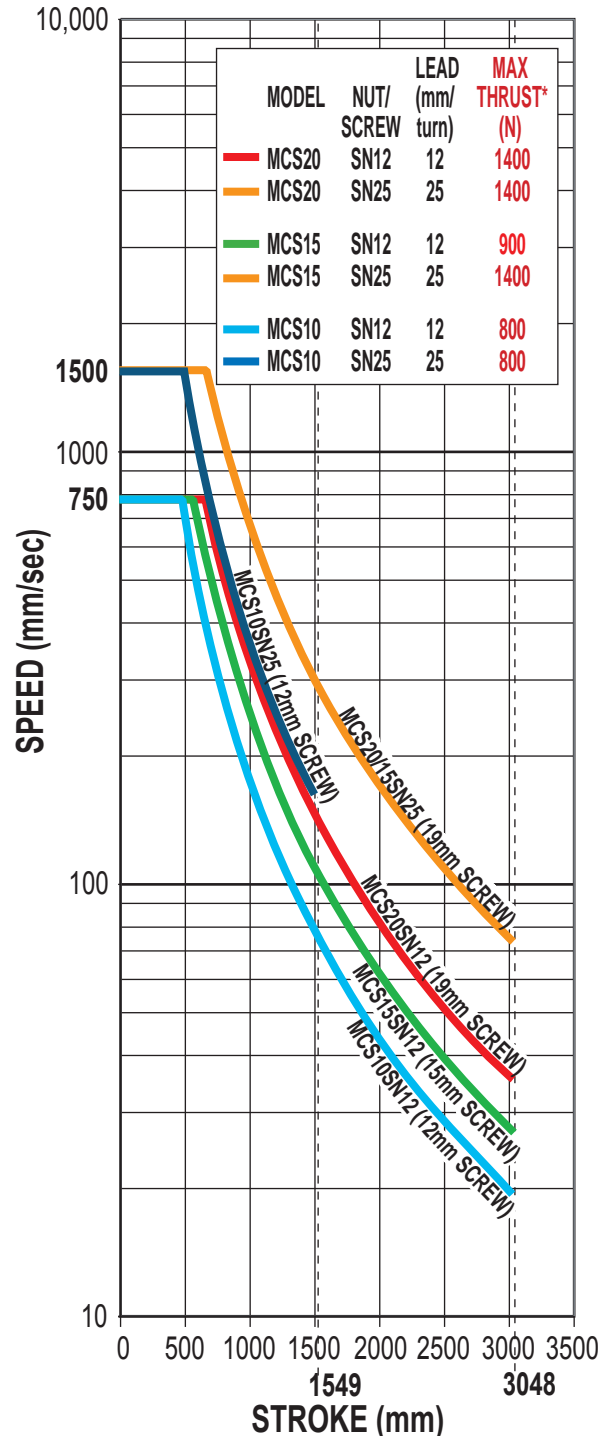

RODLESS

BCS/MCS Series

- Ball screw critical speed capacities



* Maximum thrust reflects 90% reliability for 1 million linear inches of travel.

Dotted lines represent maximum stroke for screw selections.

Refer to the technical section for each actuator body size for details on life calculations for individual screws.

Axi dyne[®] BCS/MCS Screw Drives

BALL SCREW SPECIFICATIONS

BALL SCREW LIFE CALCULATION

LIFE CAPACITIES WITH ENGLISH BALL SCREW

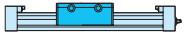
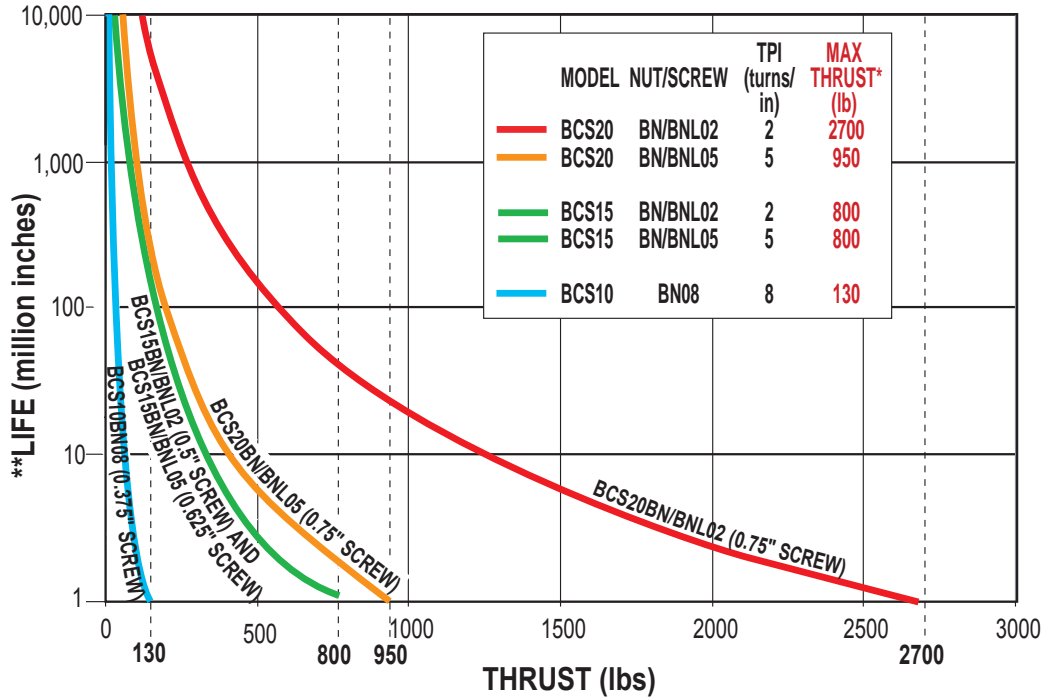

RODLESS

BCS/MCS Series

- Ball screw life calculations

LIFE CAPACITIES WITH METRIC BALL SCREW

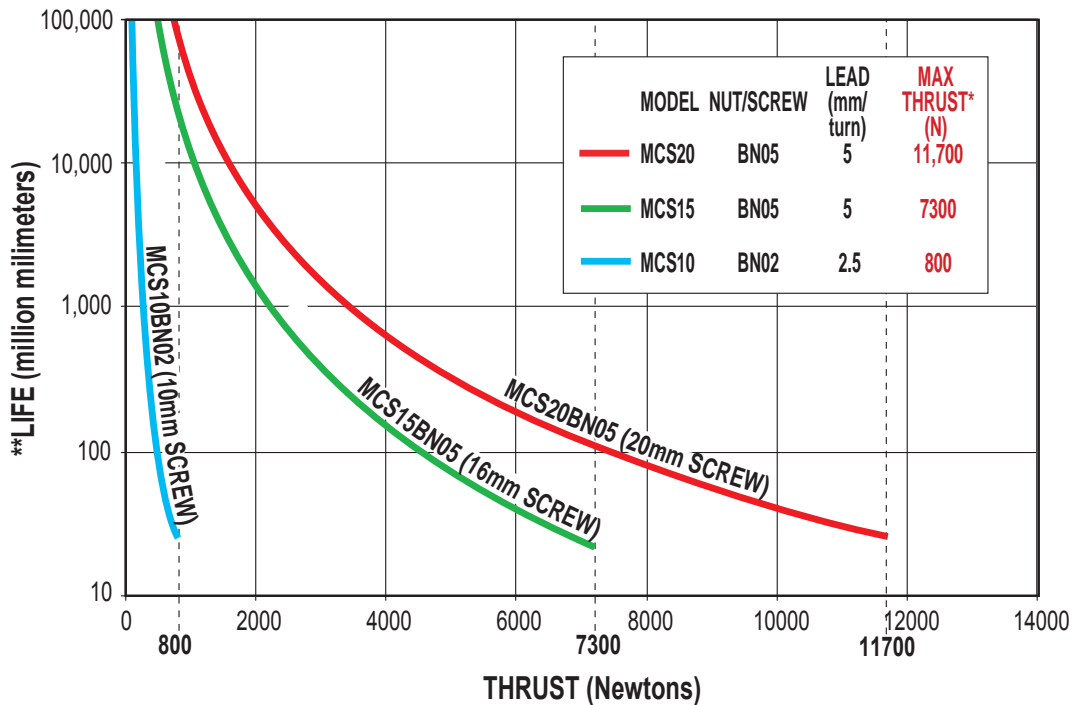

*Maximum thrust reflects 90% reliability for 1 million linear inches of travel.

Dotted lines represent maximum thrust for screw selections.

**Life indicates theoretical maximum life of screw only, under ideal conditions and does not indicate expected life of actuator.

Axi-dyne® BCS/MCS Screw Drives

OVERALL SERIES SPECIFICATIONS

SPECIFICATIONS RELATED TO ACTUATOR SIZE AND SCREW SELECTION

ENGLISH LEAD SCREWS											
ACTUATOR SERIES	SCREW DIA. (in)	SCREW TYPE	TPI (turns/in)	LEAD ACCURACY (in/ft)	BACKLASH (in)	MAXIMUM THRUST* (lb)	MAXIMUM STROKE (in)	INERTIA (lb-in ²)			BREAKAWAY TORQUE (lb-in)
								BASE ACTUATOR		PER/in OF STROKE	
								In Line	Rev. Parallel		
BCS10	0.375	BN	08	0.004	0.015	130	61	0.0046	0.0054	0.0005	1.000
	0.375	BNL	08	0.004	0.002	130	61	0.0046	0.0054	0.0005	1.000
	0.500	SN	01	0.006	0.007	170	85	0.0321	0.0348	0.0017	1.857
	0.500	SN	02	0.005	0.007	170	120	0.0190	0.0217	0.0017	1.563
	0.500	SNA	02	0.005	0.003	170	120	0.0190	0.0217	0.0017	1.563
	0.500	SN	05	0.006	0.007	170	120	0.0153	0.0180	0.0017	1.125
BCS15	0.500	BN	02	0.003	0.015	800	59	0.0299	0.0327	0.0017	1.375
	0.500	BNL	02	0.003	0.002	800	59	0.0299	0.0327	0.0017	1.375
	0.625	BN	05	0.003	0.015	800	59	0.0455	0.0524	0.0042	1.188
	0.625	BNL	05	0.003	0.002	800	59	0.0455	0.0524	0.0042	1.188
	0.625	SN	02	0.005	0.007	200	120	0.0558	0.0627	0.0042	1.563
	0.750	SN	01	0.005	0.007	300	120	0.1391	0.1536	0.0087	2.188
BCS20	0.750	BN	02	0.004	0.015	2700	120	0.1241	0.1374	0.0087	1.750
	0.750	BNL	02	0.004	0.002	2700	120	0.1241	0.1374	0.0087	1.750
	0.750	BN	05	0.003	0.015	950	120	0.1091	0.1224	0.0087	1.563
	0.750	BNL	05	0.003	0.002	950	120	0.1091	0.1224	0.0087	1.563
	0.750	SN	01	0.005	0.007	300	120	0.1775	0.1908	0.0087	3.125
	0.750	SN	02	0.005	0.007	300	120	0.1241	0.1374	0.0087	2.188

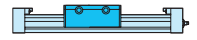

RODLESS

BCS/MCS Series
• Actuator size/screw specifications

METRIC LEAD SCREWS											
ACTUATOR SERIES	SCREW DIA. (mm)	SCREW TYPE	LEAD (mm/turn)	LEAD ACCURACY (mm/300)	BACKLASH (mm)	MAXIMUM THRUST* (N)	MAXIMUM STROKE (mm)	INERTIA (kg-m ² x 10 ⁻⁴)			BREAKAWAY TORQUE (N-m)
								BASE ACTUATOR		PER/mm OF STROKE	
								In Line	Rev. Parallel		
MCS10	10	BN	2.5	0.13	0.38	800	3048	1.58	1.87	0.176	0.13
	10	BNL	2.5	0.13	0.05	800	3048	1.58	1.87	0.176	0.13
	12	SN	12	0.13	0.18	800	3048	4.53	5.18	0.410	0.20
	12	SN	25	0.13	0.18	800	1626	8.34	8.98	0.410	0.28
MCS15	15	SN	12	0.13	0.18	900	3048	13.22	14.83	0.966	0.27
	16	BN	5	0.13	0.38	7300	3048	13.69	15.77	1.258	0.16
	16	BNL	5	0.13	0.05	7300	3048	13.69	15.77	1.258	0.16
	19	SN	25	0.13	0.18	1400	3048	39.98	44.17	2.517	0.32
MCS20	19	SN	12	0.13	0.18	1400	3048	35.42	39.28	2.517	0.39
	19	SN	25	0.13	0.18	1400	3048	50.95	54.81	2.517	0.57
	20	BN	5	0.13	0.38	11700	3048	38.61	43.32	3.102	0.25
	20	BNL	5	0.13	0.05	11700	3048	38.61	43.32	3.102	0.25

SCREW CODE	DESCRIPTION
SN	Solid Nut
SNA	Anti-backlash Solid Nut
BN	Ball Nut
BNL	Low-Backlash Ball Nut



Contact the factory for higher accuracy and lower backlash options.

* For Acme screws, maximum thrust is the maximum continuous dynamic thrust subject to Thrust x Velocity limitation.

For ball screws, maximum thrust reflects 90% reliability for 1 million linear inches of travel.

Axi-dyne® BCS/MCS Screw Drives

OVERALL SERIES SPECIFICATIONS

GENERAL ACTUATOR SPECIFICATIONS

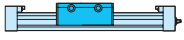

RODLESS

BCS/MCS Series

- General actuator specifications
- Friction force
- Support recommendations

BCS ENGLISH ACTUATORS					
ACTUATOR SERIES	CARRIER WEIGHT (lb)	BASE WEIGHT (lb) (Including Carrier)	WEIGHT PER/IN OF STROKE (lb)	TEMPERATURE RANGE* (F°)	IP RATING**
BCS10	0.69	2.91	0.176	40 - 130	44
BCS15	1.94	6.61	0.392	40 - 130	44
BCS20	2.81	14.59	0.666	40 - 130	44

MCS METRIC ACTUATORS					
ACTUATOR SERIES	CARRIER WEIGHT (kg)	BASE WEIGHT (kg) (Including Carrier)	WEIGHT PER/mm OF STROKE (g)	TEMPERATURE RANGE* (C°)	IP RATING**
MCS10	0.31	1.32	3.1	4 - 54	44
MCS15	0.88	2.90	7.0	4 - 54	44
MCS20	1.27	6.62	11.9	4 - 54	44



* Heat generated by the motor and drive should be taken into consideration as well as linear velocity and work cycle time. For applications that require operation outside of the recommended temperature range, contact the factory.

** Protected against ingress of solid particles greater than .039 in (1mm) and splashing water

LARGE FRAME MOTORS AND SMALLER SIZE ACTUATORS: Cantilevered motors need to be supported, if subjected to continuous rapid reversing duty and/or under dynamic conditions.

FRICITION FORCE

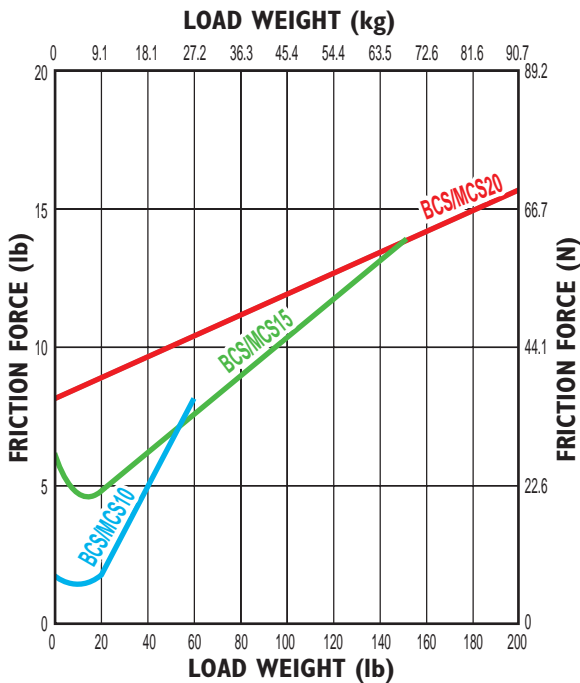

SUPPORT RECOMMENDATIONS

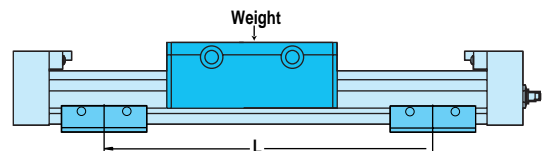
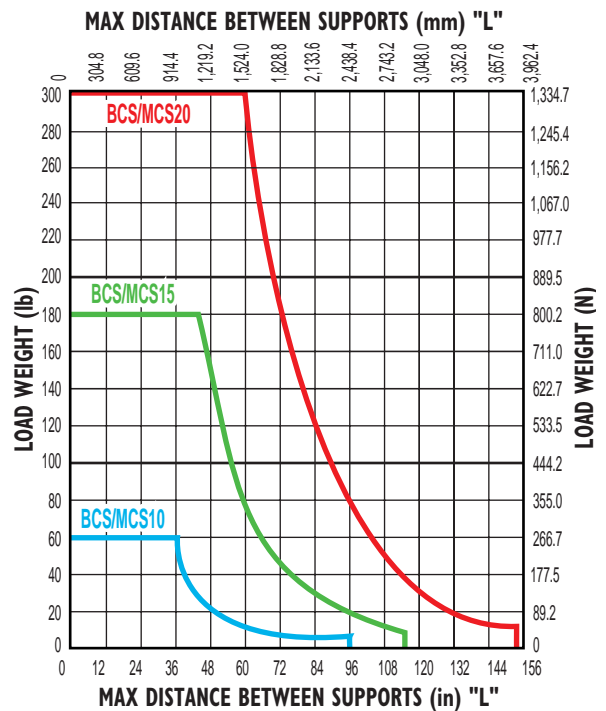

Axi-dyne® BCS/MCS Screw Drives

OVERALL SERIES SPECIFICATIONS

DYNAMIC BENDING MOMENTS AND LOADS

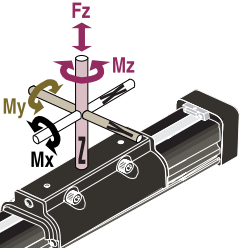
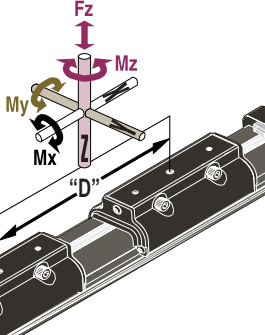
STANDARD CARRIER	MAXIMUM BENDING MOMENTS AND LOADS		ENGLISH			METRIC		
			BCS10	BCS15	BCS20	MCS10	MCS15	MCS20
	Mx Moment (Roll)	(lb-in : N-m)	55	275	300	6.2	31.1	33.9
	My Moment (Pitch)	(lb-in : N-m)	100	500	1100	11.3	56.5	124.3
	Mz Moment (Yaw)	(lb-in : N-m)	30	200	325	3.4	22.6	36.7
	Fz Load (Lateral)	(lb : N)	60	180	300	267	801	1335
AUXILIARY CARRIER: Increases rigidity, load-carrying capacity and moments			BCS10	BCS15	BCS20	MCS10	MCS15	MCS20
	Mx Moment (Roll)	*(lb-in : N-m)	110	550	600	12.4	62.1	67.8
	My Moment (Pitch)	*(lb-in : N-m)	287	1453	2430	32.4	164.1	274.6
	Mz Moment (Yaw)	*(lb-in : N-m)	287	1453	2430	32.4	164.1	274.6
	Fz Load (Lateral)	(lb : N)	120	360	600	534	1602	2670
	Minimum Dimension 'D'	(in : mm)	5.10	6.50	8.10	129.5	165.0	206.0

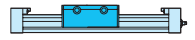

RODLESS

BCS/MCS Series

- Bending moments and loads
- Auxiliary carrier

⚠ Breakaway torque will increase when using the Auxiliary carrier option. When ordering, determine your working stroke and enter this value into the configuration string. Overall actuator length will automatically be calculated.

*Loads shown in table are at minimum "D" dimension, for ratings with longer "D" dimension see graph below.

AUXILIARY CARRIER: BENDING MOMENT AT 'D' DISTANCE

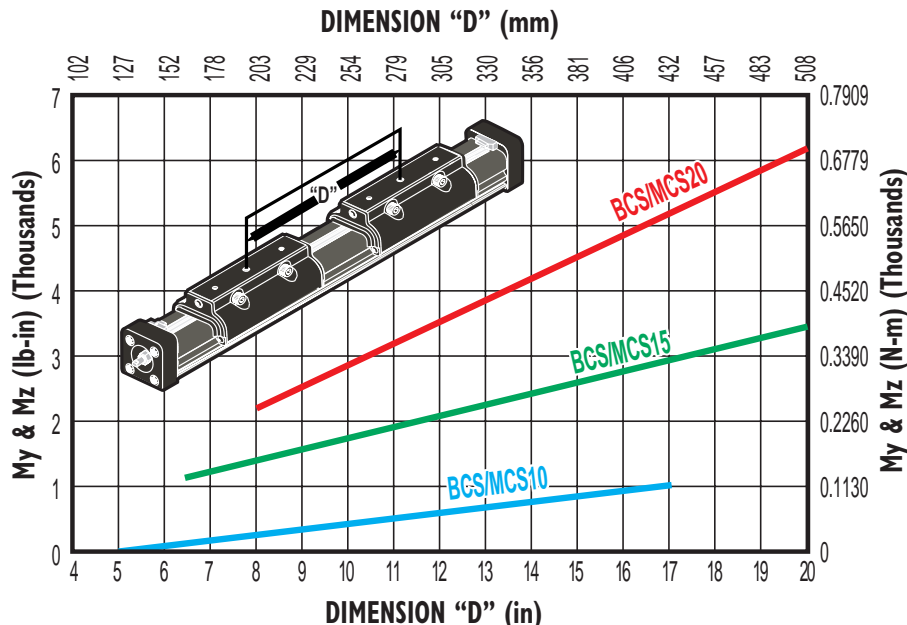

Rates shown on charts were calculated with these assumptions:

- 1.) Coupling between carriers is rigid.
- 2.) Load is equally distributed between carriers.
- 3.) Coupling device applies no misalignment loads to carriers.

* Customer must specify Dimension "D" (Distance between carrier center lines) in configuration string.

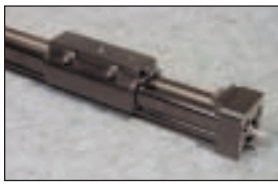

Axi
dyne[®]

BCS/MCS10 Series ACME SCREW SPECIFICATIONS

BCS10/MCS10 ACME SCREW CRITICAL SPEED AND PV LIMITS

CRITICAL SPEED WITH 1/2" ENGLISH ACME SCREW

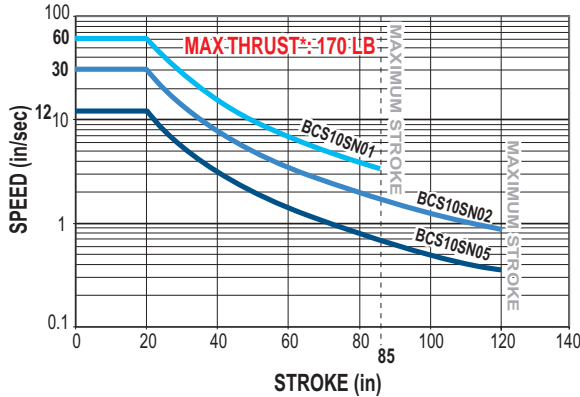

CRITICAL SPEED WITH 12mm METRIC ACME SCREW

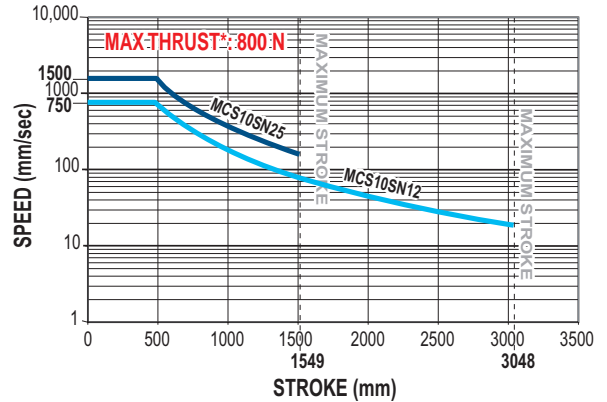

PV LIMITS: 1/2" 1 TPI ENGLISH ACME SCREW

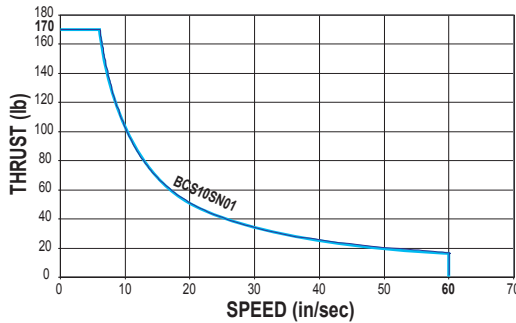

PV LIMITS: 12mm ACME METRIC SCREW w/25mm LEAD

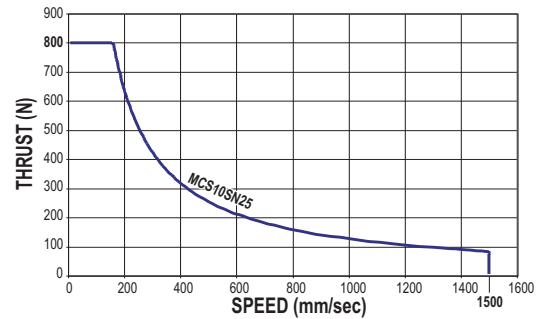

PV LIMITS: 1/2" 2 TPI ENGLISH ACME SCREW

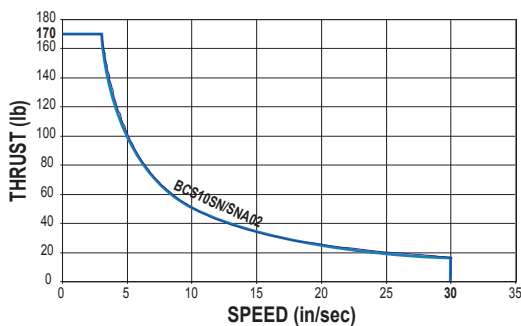

PV LIMITS: 12mm ACME METRIC SCREW w/12mm LEAD

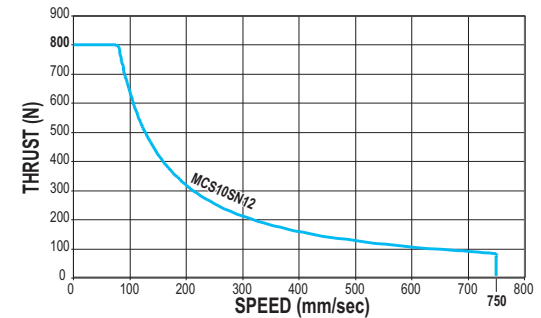

PV LIMITS: 1/2" 5 TPI ENGLISH ACME SCREW

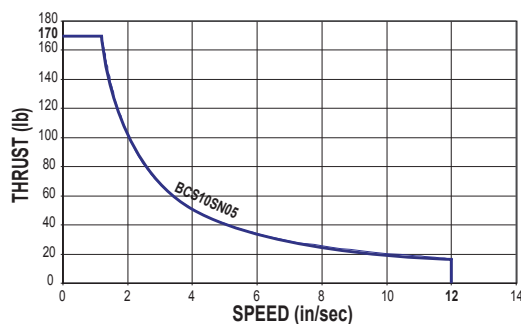

SN = Solid Nut

SNA = Solid Anti-backlash Nut

⚠️ *Maximum thrust is the maximum continuous dynamic thrust subject to Thrust x Velocity limitation.

PV LIMITS: Any material which carries a sliding load is limited by heat buildup. The factors that affect heat generation rate in an application are the pressure on the nut in pounds per square inch and the surface velocity in feet per minute. The product of these factors provides a measure of the severity of an application.

$$P = \frac{\text{Thrust}}{\text{Max. Thrust Rating}} \times V = \frac{\text{Speed}}{\text{Max. Speed Rating}} \leq 0.1$$

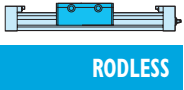

RODLESS

BCS/MCS10 Series

- Acme screw critical speed capacities and PV limits

Axi-dyne® BCS/MCS10 Series

BALL SCREW SPECIFICATIONS

BCS/MCS10 BALL SCREW SPECIFICATIONS

CRITICAL SPEED WITH 3/8" ENGLISH BALL SCREW

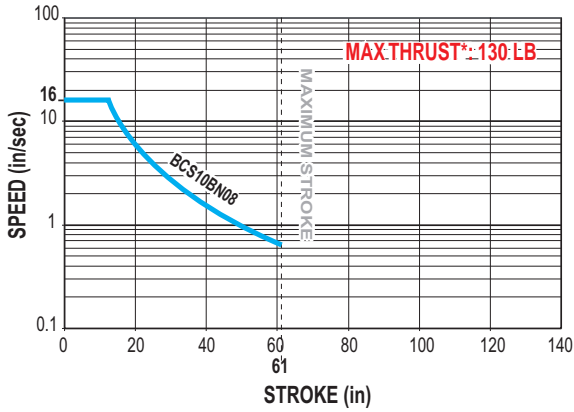

CRITICAL SPEED WITH 10mm METRIC BALL SCREW

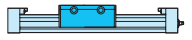
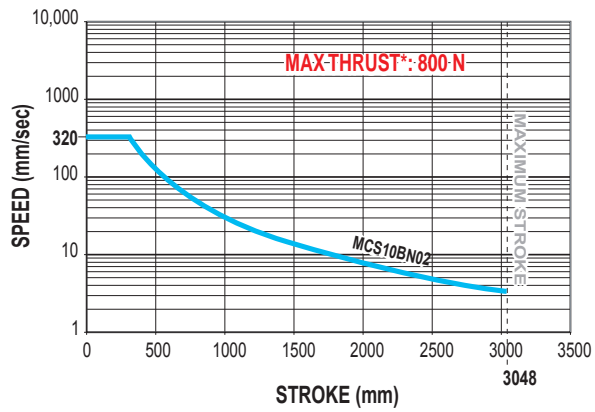

RODLESS

BCS/MCS10 Series

- Ball screw critical speed capacities and life calculations

LIFE CALCULATION: 3/8" 8TPI ENGLISH BALL SCREW

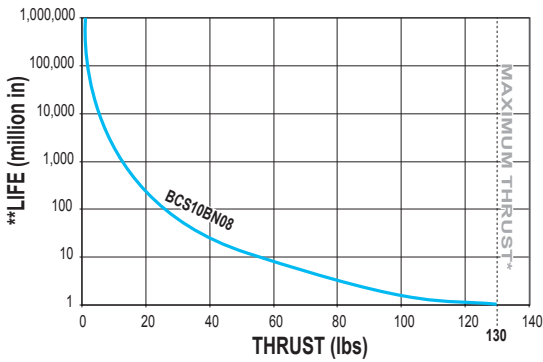

LIFE CALCULATION: 10mm METRIC BALL SCREW w/2.5mm LEAD

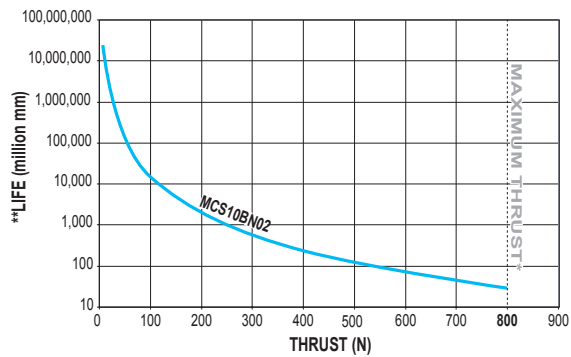

BN = Ball Nut



* Maximum thrust reflects 90% reliability for 1 million linear inches of travel.

**Life indicates theoretical maximum life of screw only, under ideal conditions and does not indicate expected life of actuator.

Axi dyne[®] BCS/MCS10 Series

DIMENSIONS

BCS10/MCS10 ACTUATOR AND OPTIONS

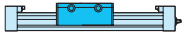

RODLESS

BCS/MCS10 Series

• Actuator and options dimensions

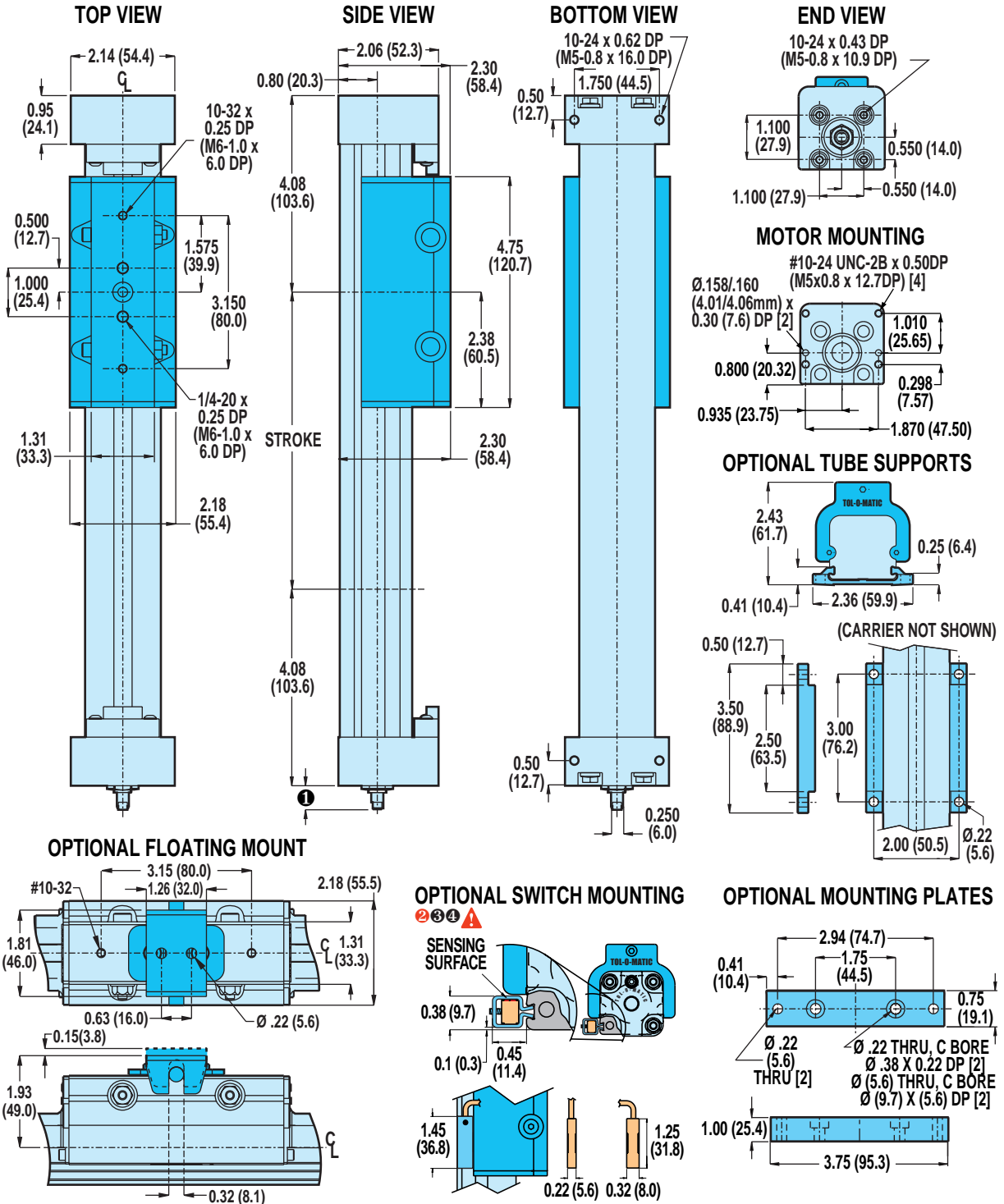

① SHAFT LENGTH

In-line mounting	0.53 (13.5)
Extended shaft for RP & 23-frame motor	1.89 (48.0)
Extended shaft for RP & 34-frame motor	2.10 (53.3)
Extended shaft for purchases prior to 6/24/02	1.53 (38.9)

⚠ CAUTION: DO NOT OVERTIGHTEN SWITCH HARDWARE WHEN INSTALLING

② NOTE: The scored face of the switch indicates the sensing surface and must face toward the magnet

③ NOTE: Some actuators require switch mounting on a specific side of the actuator. Call Tol-O-Matic 1-800-328-2174 for details

Unless otherwise noted, all dimensions shown are in inches (Dimensions in parenthesis are in millimeters)

DIMENSIONS

BCS/MCS10: IN-LINE MOUNT FOR 23-FRAME STEPPER (MRS) OR BRUSHED DC (MRB) MOTORS (Not for use with gearhead reduction)

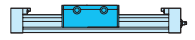
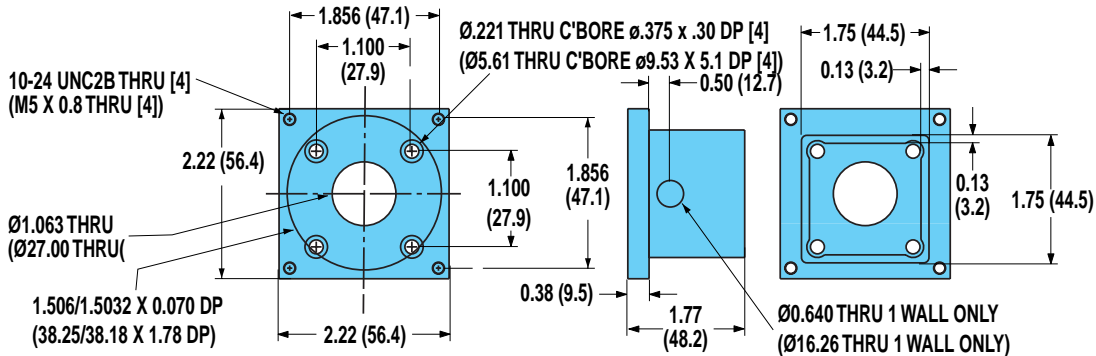

RODLESS

BCS/MCS10 Series

- In-line motor mounting

BCS/MCS10: IN-LINE MOUNT FOR 34-FRAME STEPPER (MRS) OR BRUSHED DC (MRB) MOTORS (Not for use with gearhead reduction)

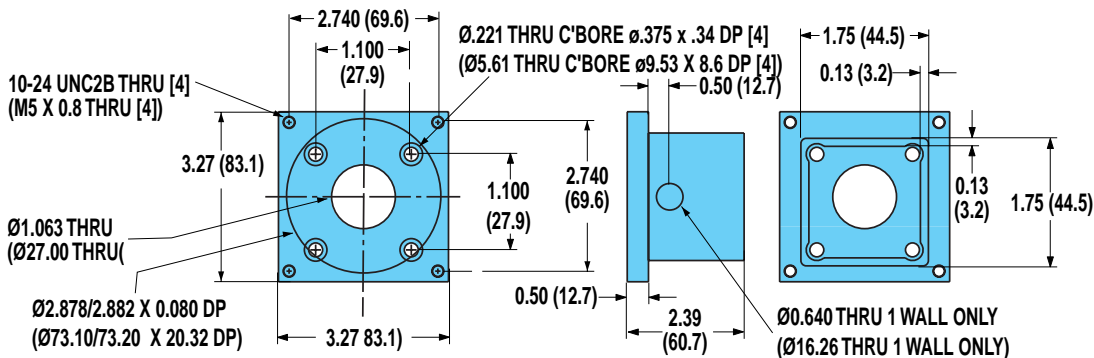

BCS/MCS10: IN-LINE MOUNT FOR BRUSHLESS SERVO (MRV) MOTORS OR GEARHEADS

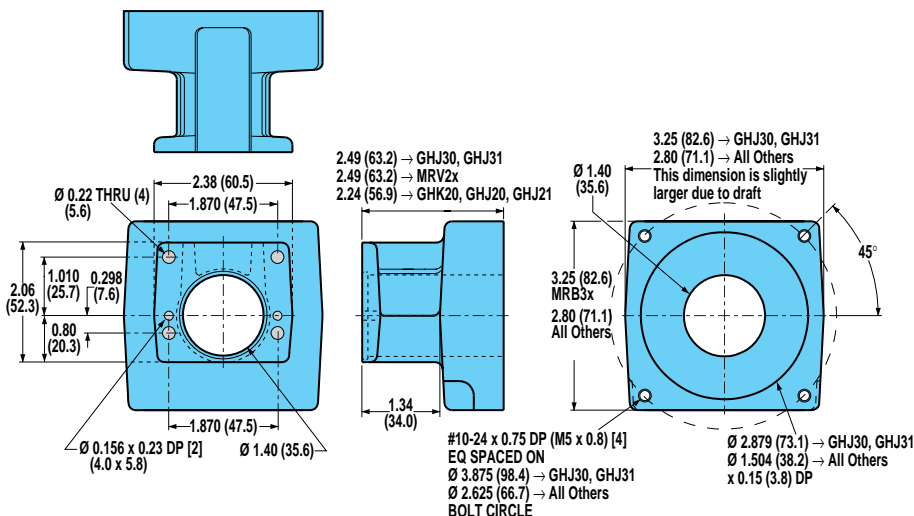

For a complete part listing of screw-drive motor and gearhead mounting kits referencing actuator/motor/coupler compatibilities, refer to document 3600-4631 available on the Literature/Part Sheet/Axidyne section of our web site at: www.tolomatic.com.

For gearhead dimensions and specifications, refer to page F-10.

Axi dyne® BCS/MCS10 Series

DIMENSIONS

BCS/MCS10: REVERSE PARALLEL MOUNTING

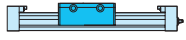
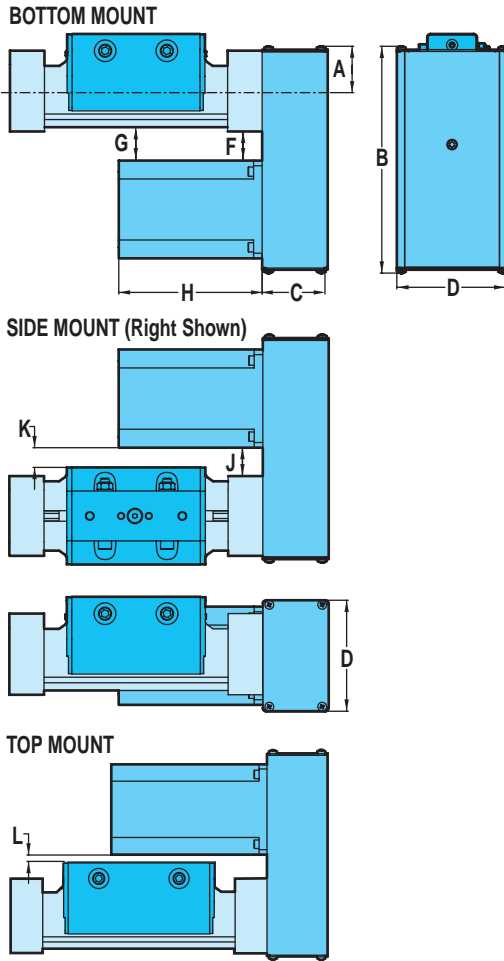

RODLESS

BCS/MCS10 Series

- Reverse parallel mounting

SPECIFICATIONS

MOTOR	WEIGHT OF REDUCTION DRIVE				REDUCTION INERTIA AT MOTOR SHAFT				
	1:1		2:1		1:1		2:1		
	lbs	kg	lbs	kg	lb-in ²	kg-m ² x 10 ⁻⁴	lb-in ²	kg-m ² x 10 ⁻⁴	
BRUSHLESS MRV21, 22, 23, 24	2.06	0.9344	2.06	.9344	0.0875	25.59	32.91	3.30	
STEPPER	MRS231, 232	1.92	0.8709	1.92	.8709	0.0219	6.41	0.0463	13.54
	MRS341, 342, 343	2.34	1.0614	2.34	1.0614	0.0250	7.31	0.0500	14.61
BRUSHED	MRB21	1.92	0.8709	1.92	0.8709	0.0219	6.41	0.0463	13.54
	MRB31, 32	2.46	1.1158	2.46	1.1158	0.0875	25.59	0.1125	32.90

REDUCTION EFFICIENCY: 0.95

DIMENSIONS

	MOTOR	A		B		C		D		F		G		H		J		K		L	
		in.	mm	in.	mm	in.	mm	in.	mm	in.	mm	in.	mm	in.	mm	in.	mm	in.	mm	in.	mm
BRUSHLESS	MRV21	1.44	36.6	6.96	176.7	2.13	54.0	3.25	82.6	1.81	45.9	1.83	46.5	4.75	120.7	1.54	39.1	1.83	46.5	1.11	28.2
	MRV22	1.44	36.6	6.96	176.7	2.13	54.0	3.25	82.6	1.81	45.9	1.83	46.5	5.75	146.1	1.54	39.1	1.83	46.5	1.11	28.2
	MRV23	1.44	36.6	6.96	176.7	2.13	54.0	3.25	82.6	1.81	45.9	1.83	46.5	6.75	171.5	1.54	39.1	1.83	46.5	1.11	28.2
	MRV24	1.44	36.6	6.96	176.7	2.13	54.0	3.25	82.6	1.81	45.9	1.83	46.5	7.75	196.9	1.54	39.1	1.83	46.5	1.11	28.2
STEPPER	MRS231	1.44	36.6	6.96	176.7	2.13	54.0	3.25	82.6	1.81	45.9	1.83	46.5	2.06	52.3	1.54	39.1	1.83	46.5	1.11	28.2
	MRS232	1.44	36.6	6.96	176.7	2.13	54.0	3.25	82.6	1.81	45.9	1.83	46.5	3.10	78.7	1.54	39.1	1.83	46.5	1.11	28.2
	MRS341	1.96	49.7	7.47	189.8	2.38	60.3	4.00	101.6	1.24	31.5	1.26	32.0	2.58	65.5	0.97	24.6	1.26	32.0	0.54	13.7
	MRS342	1.96	49.7	7.47	189.8	2.38	60.3	4.00	101.6	1.24	31.5	1.26	32.0	3.76	95.5	0.97	24.6	1.26	32.0	0.54	13.7
BRUSHED	MRS343	1.96	49.7	7.47	189.8	2.38	60.3	4.00	101.6	1.24	31.5	1.26	32.0	5.06	128.5	0.97	24.6	1.26	32.0	0.54	13.7
	MRB21	1.44	36.6	6.96	176.8	2.13	54.0	3.25	82.6	1.81	45.9	1.83	46.5	6.33	160.8	1.54	39.1	1.83	46.5	1.11	28.2
	MRB31	1.96	49.8	6.96	176.8	2.38	60.3	4.00	101.6	1.30	33.0	1.32	33.5	5.07	128.8	1.03	26.2	1.32	33.5	0.60	15.2
	MRB32	1.96	49.8	7.47	189.7	2.38	60.3	4.00	101.6	1.30	33.0	1.32	33.5	7.72	196.1	1.03	26.2	1.32	33.5	0.60	15.2



BCS15 ENGLISH ACME SCREW SPECIFICATIONS

CRITICAL SPEED WITH 5/8" ENGLISH ACME SCREW

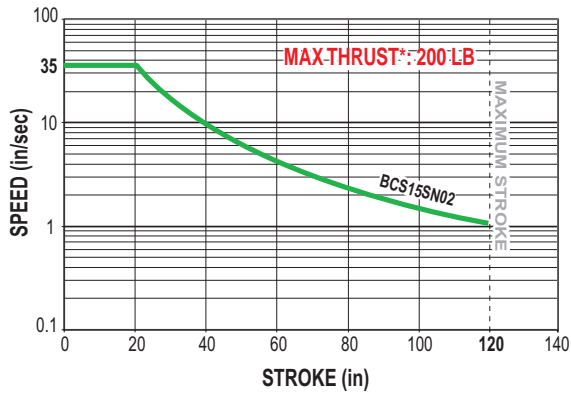

CRITICAL SPEED WITH 3/4" ENGLISH ACME SCREW

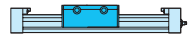
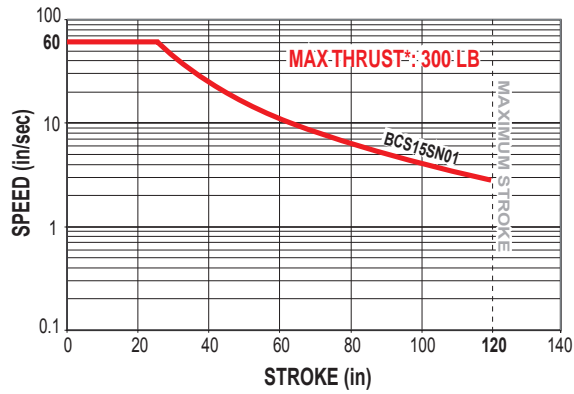

RODLESS

BCS/MC15S Series

- English acme screw critical speed capacities and PV limits

PV LIMITS: 5/8" 2TPI ENGLISH ACME SCREW

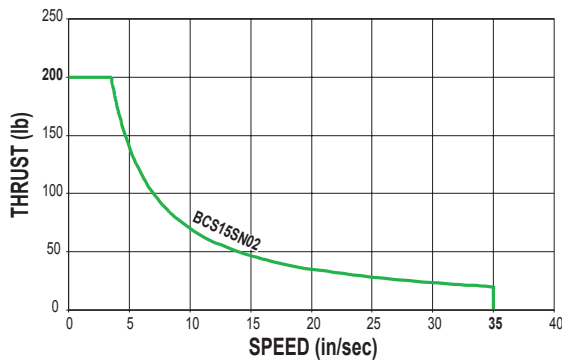

PV LIMITS: 3/4" 1TPI ENGLISH ACME SCREW

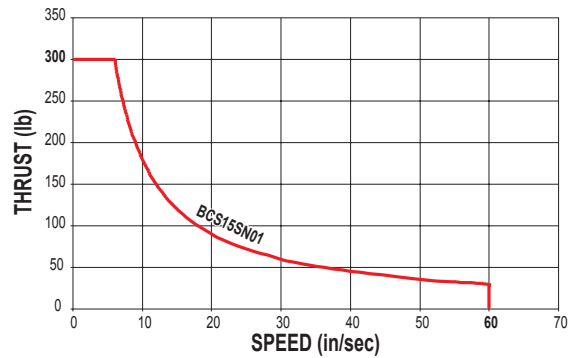

SN = Solid Nut

SNA = Solid Anti-backlash Nut



**Maximum thrust is the maximum continuous dynamic thrust subject to Thrust x Velocity limitation.*

PV LIMITS: Any material which carries a sliding load is limited by heat buildup. The factors that affect heat generation rate in an application are the pressure on the nut in pounds per square inch and the surface velocity in feet per minute. The product of these factors provides a measure of the severity of an application.

$$P = \frac{\text{Thrust}}{\text{Max. Thrust Rating}} \times V = \frac{\text{Speed}}{\text{Max. Speed Rating}} \leq 0.1$$

Axi-dyne[®] BCS/MCS15 Series

ACME SCREW SPECIFICATIONS

MCS15 METRIC ACME SCREW SPECIFICATIONS

CRITICAL SPEED WITH 15mm METRIC ACME SCREW

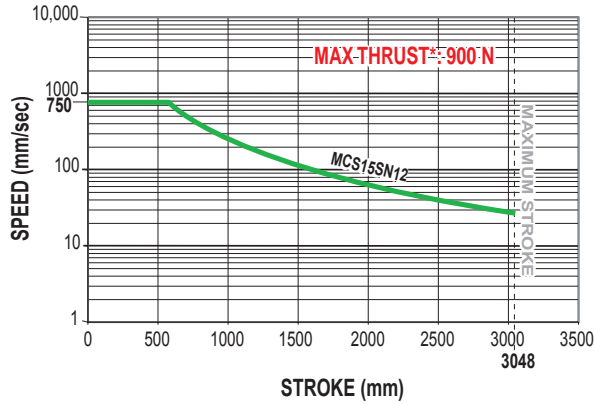

CRITICAL SPEED WITH 19mm METRIC ACME SCREW

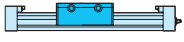
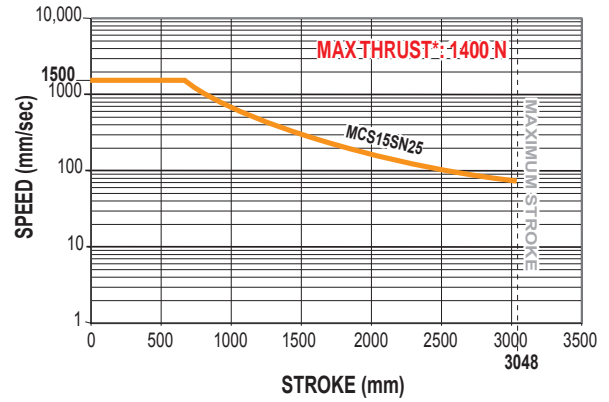

RODLESS

BCS/MCS15 Series

- Metric acme screw critical speed capacities and PV limits

PV LIMITS: 15mm METRIC ACME SCREW w/12mm LEAD

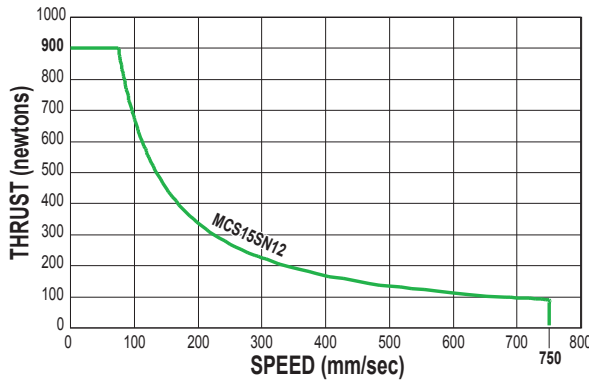

PV LIMITS: 19mm METRIC ACME SCREW w/25mm LEAD

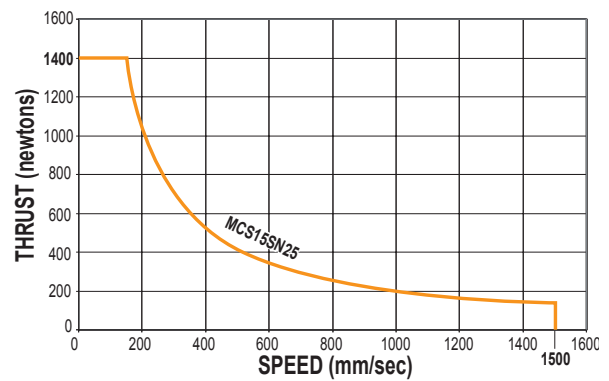

SN = Solid Nut



** Maximum thrust is the maximum continuous dynamic thrust subject to Thrust x Velocity limitation.*

PV LIMITS: Any material which carries a sliding load is limited by heat buildup. The factors that affect heat generation rate in an application are the pressure on the nut in pounds per square inch and the surface velocity in feet per minute. The product of these factors provides a measure of the severity of an application.

$$P = \frac{\text{Thrust}}{\text{Max. Thrust Rating}} \times V = \frac{\text{Speed}}{\text{Max. Speed Rating}} \leq 0.1$$

Axi-dyne® BCS/MCS15 Series

BALL SCREW SPECIFICATIONS

BCS/MCS15 BALL SCREW SPECIFICATIONS

CRITICAL SPEED WITH 1/2" ENGLISH BALL SCREW

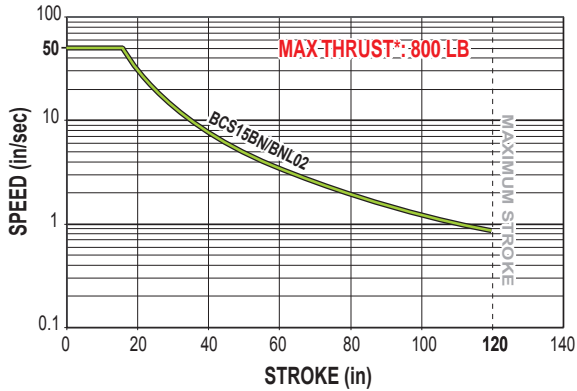

CRITICAL SPEED WITH 16mm METRIC BALL SCREW

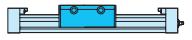
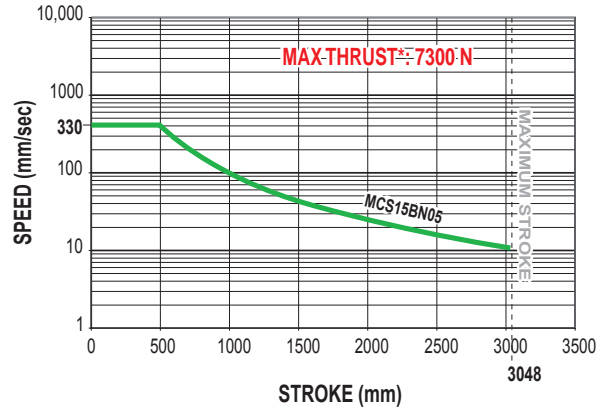

RODLESS

BCS/MCS15 Series

- Ball screw critical speed capacities and life calculations

CRITICAL SPEED WITH 5/8" ENGLISH BALL SCREW

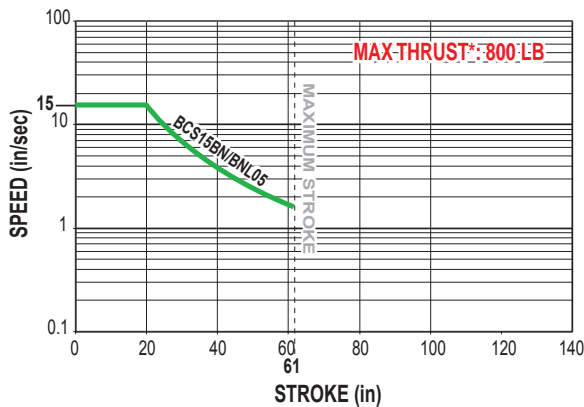

LIFE CALCULATION: 16mm METRIC BALL SCREW w/5mm LEAD

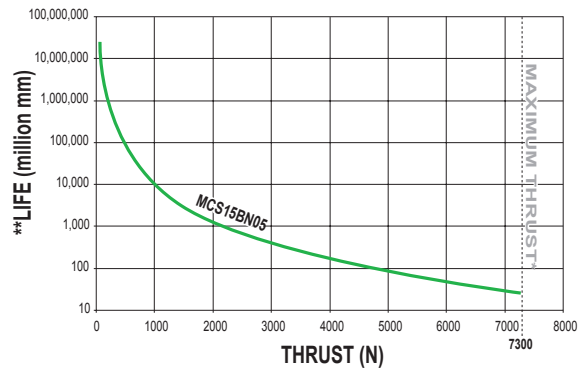

LIFE CALCULATION: 1/2" w/2TPI & 5/8" w/5TPI ENGLISH BALL SCREW

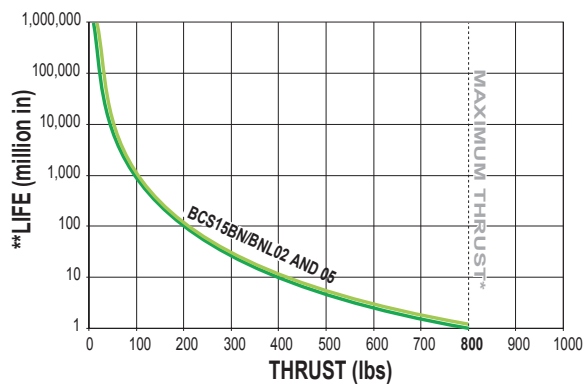

BN = Ball Nut

BNL = Ball Nut with Low-Backlash



* Maximum thrust reflects 90% reliability for 1 million linear inches of travel.

**Life indicates theoretical maximum life of screw only, under ideal conditions and does not indicate expected life of actuator.

Axi-dyne[®] BCS/MCS15 Series

OVERVIEW

BCS15/MCS15 ACTUATOR AND OPTIONS

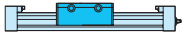

RODLESS

BCS/MCS15 Series

• Actuator and options dimensions

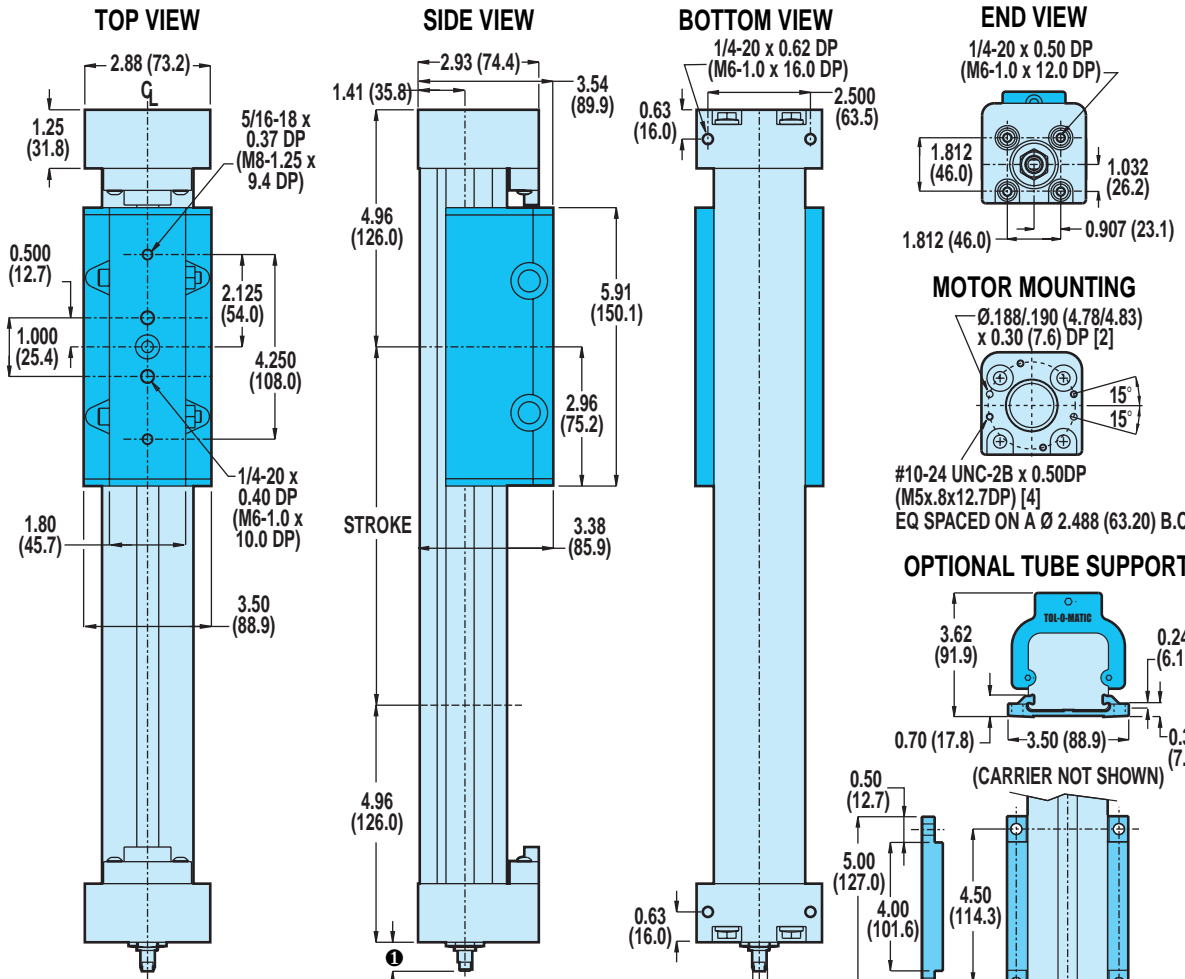

MOTOR MOUNTING

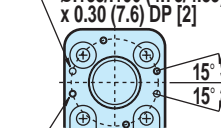

#10-24 UNC-2B x 0.50DP (M5x.8x12.7DP) [4]
 EQ SPACED ON A $\varnothing 2.488$ (63.20) B.C.

OPTIONAL TUBE SUPPORTS

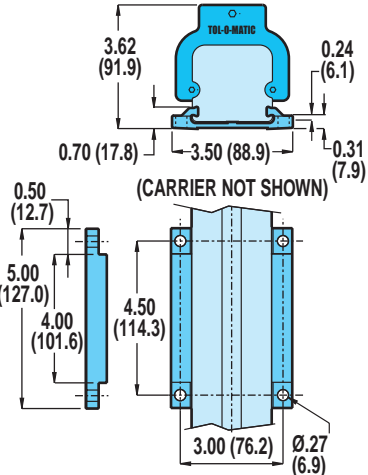

OPTIONAL FLOATING MOUNT

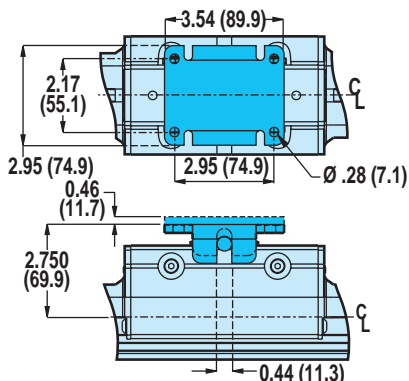

OPTIONAL SWITCH MOUNTING

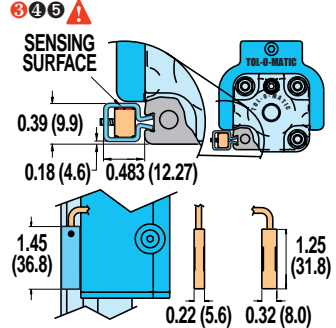

OPTIONAL MOUNTING PLATES

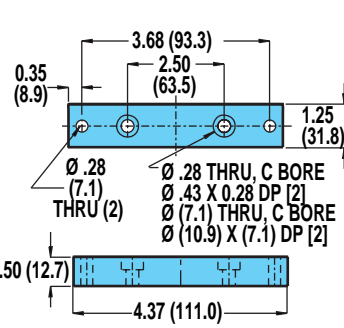

1 SHAFT LENGTH	2 FOR 1/2" 2TPI BALL-SCREW STYLE ONLY	3 NOTE: The scored face of the switch indicates the sensing surface and must face toward the magnet
In-line mounting 0.65 (16.5)		4 NOTE: Some actuators require switch mounting on a specific side of the actuator. Call Tol-O-Matic 1-800-328-2174 for details
Extended shaft for RP & 23-frame motor 1.94 (49.3)		
Extended shaft for RP & 34-frame motor 2.15 (54.6)		
Extended shaft for RP & 40-frame motor 2.31 (58.7)		
Extended shaft for purchases prior to 6/24/02 1.92 (48.8)		

3 CAUTION: DO NOT OVERTIGHTEN SWITCH HARDWARE WHEN INSTALLING

Unless otherwise noted, all dimensions shown are in inches (Dimensions in parenthesis are in millimeters)

OVERVIEW

BCS/MCS15: IN-LINE MOUNT FOR 23-FRAME STEPPER (MRS) OR BRUSHED DC (MRB) MOTORS (Not for use with gearhead reduction)

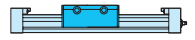
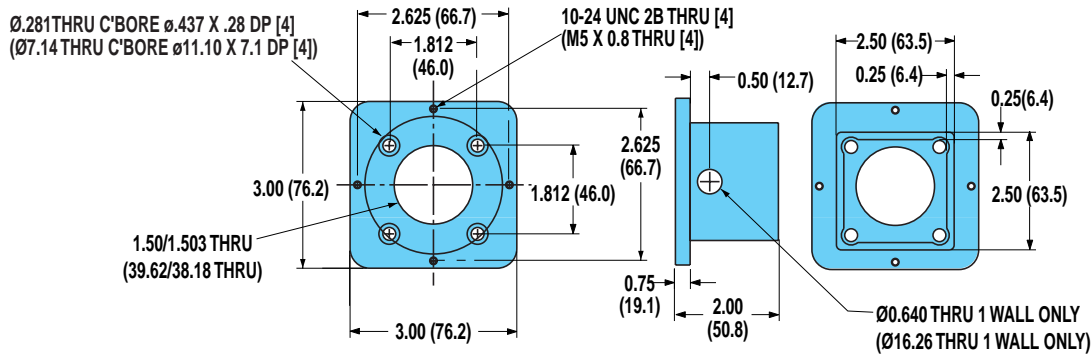

RODLESS

BCS/MCS15 Series

- In-line motor mounting

BCS/MCS15: IN-LINE MOUNT FOR 34-FRAME STEPPER (MRS) OR BRUSHED DC (MRB) MOTORS (Not for use with gearhead reduction)

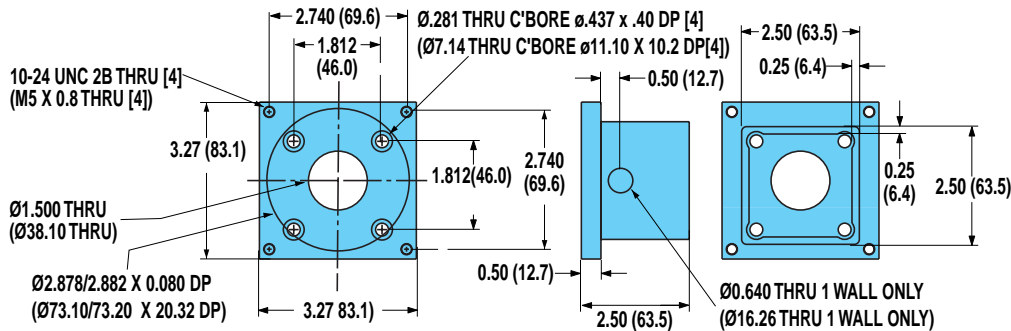

BCS/MCS15: IN-LINE MOUNT FOR BRUSHLESS SERVO (MRV) MOTORS, BRUSHED DC (MRB41, 42) MOTORS OR GEARHEADS

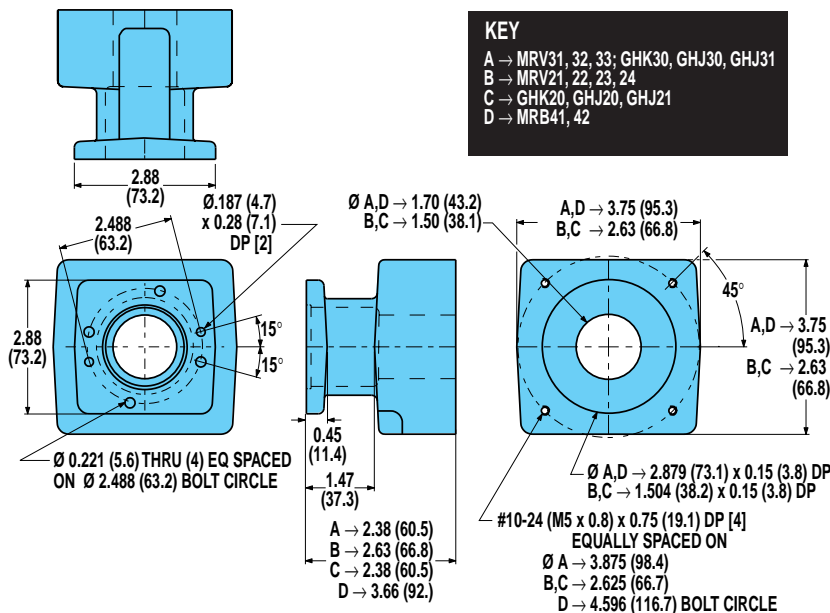

KEY

- A → MRV31, 32, 33; GHK30, GHJ30, GHJ31
- B → MRV21, 22, 23, 24
- C → GHK20, GHJ20, GHJ21
- D → MRB41, 42



For a complete part listing of screw-drive motor and gearhead mounting kits referencing actuator/motor/coupler compatibilities, refer to document 3600-4631 available on the Literature/Part Sheet/Axidyne section of our web site at: www.tolomatic.com.

For gearhead dimensions and specifications, refer to page F-10.

Axi dyne® BCS/MCS15 Series

DIMENSIONS

BCS/MCS15: REVERSE PARALLEL MOUNTING

BOTTOM MOUNT

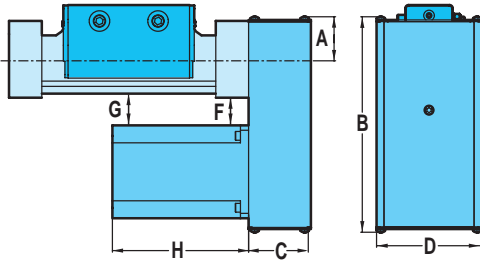

SIDE MOUNT (Right Shown)

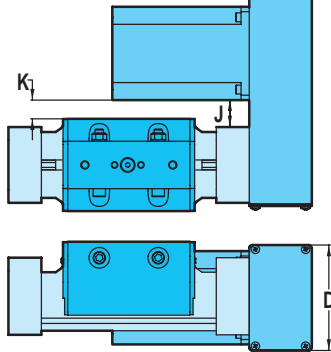

TOP MOUNT

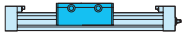
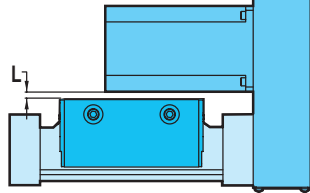

RODLESS

BCS/MCS15 Series

- Reverse parallel mounting dimensions

SPECIFICATIONS

MOTOR	WEIGHT OF REDUCTION DRIVE				REDUCTION INERTIA AT MOTOR SHAFT				
	1:1		2:1		1:1		2:1		
	lbs	kg	lbs	kg	lb-in ²	kg-m ² x 10 ⁻⁶	lb-in ²	kg-m ² x 10 ⁻⁶	
BRUSHLESS	MRV21, 22, 23, 24	2.17	0.9843	2.40	1.0886	0.0875	25.59	0.1206	35.28
	MRV31, 32, 33	2.61	1.1839	2.84	1.2882	.0875	25.59	.1206	35.28
STEPPER	MRS231, 232	2.03	.9208	2.26	1.0251	.0219	6.41	.0544	15.91
	MRS341, 342, 343	2.49	1.1294	2.72	1.2338	.0250	7.31	.0575	16.82
BRUSHED	MRB21	2.03	.9208	2.26	1.0251	.0219	6.41	.0544	15.91
	MRB31, 32	2.61	1.1839	2.84	1.2882	.0875	25.59	.1206	35.28
	MRB41, 42	3.73	1.6919	3.96	1.7962	.1119	32.73	.1444	42.24

REDUCTION EFFICIENCY: 0.95

DIMENSIONS

	MOTOR	A		B		C		D		F		G		H		J		K		L	
		in.	mm	in.	mm	in.	mm	in.	mm	in.	mm	in.	mm	in.	mm	in.	mm	in.	mm	in.	mm
BRUSHLESS	MRV21	1.44	36.6	7.46	189.4	2.13	54.0	3.25	82.6	1.70	43.2	1.85	47.0	4.75	120.7	1.67	42.4	1.86	47.2	0.98	25.3
	MRV22	1.44	36.6	7.46	189.4	2.13	54.0	3.25	82.6	1.70	43.2	1.85	47.0	5.75	146.1	1.67	42.4	1.86	47.2	0.98	25.3
	MRV23	1.44	36.6	7.46	189.4	2.13	54.0	3.25	82.6	1.70	43.2	1.85	47.0	6.75	171.5	1.67	42.4	1.86	47.2	0.98	25.3
	MRV24	1.44	36.6	7.46	189.4	2.13	54.0	3.25	82.6	1.70	43.2	1.85	47.0	7.75	196.9	1.67	42.4	1.86	47.2	0.98	25.3
	MRV31	2.12	53.8	8.14	206.6	2.38	60.3	4.00	101.6	1.05	26.7	1.21	30.7	6.11	155.2	1.02	25.9	1.21	30.7	0.33	8.9
	MRV32	2.12	53.8	8.14	206.6	2.38	60.3	4.00	101.6	1.05	26.7	1.21	30.7	7.36	186.9	1.02	25.9	1.21	30.7	0.33	8.9
MRV33	2.12	53.8	8.14	206.6	2.38	60.3	4.00	101.6	1.05	26.7	1.21	30.7	8.61	218.7	1.02	25.9	1.21	30.7	0.33	8.9	
STEPPER	MRS231	1.44	36.6	7.46	189.4	2.13	54.0	3.25	82.6	1.70	43.2	1.85	47.0	2.06	52.3	1.67	42.4	1.86	47.2	0.98	25.3
	MRS232	1.44	36.6	7.46	189.4	2.13	54.0	3.25	82.6	1.70	43.2	1.85	47.0	3.10	78.7	1.67	42.4	1.86	47.2	0.98	25.3
	MRS341	2.12	53.8	8.14	206.6	2.38	60.3	4.00	101.6	1.13	28.7	1.29	32.8	2.58	65.5	1.10	27.9	1.29	32.8	0.41	11.0
	MRS342	2.12	53.8	8.14	206.6	2.38	60.3	4.00	101.6	1.13	28.7	1.29	32.8	3.76	95.5	1.10	27.9	1.29	32.8	0.41	11.0
	MRS343	2.12	53.8	8.14	206.6	2.38	60.3	4.00	101.6	1.13	28.7	1.29	32.8	5.06	128.5	1.10	27.9	1.29	32.8	0.41	11.0
BRUSHED	MRB21	1.44	36.6	7.46	189.4	2.13	54.0	3.25	82.6	1.70	43.2	1.85	47.0	6.33	160.8	1.67	42.4	1.86	47.2	0.98	25.3
	MRB31	2.12	53.8	8.14	206.6	2.38	60.3	4.00	101.6	1.19	30.2	1.35	34.3	5.07	128.8	1.16	29.5	1.35	34.3	0.47	12.5
	MRB32	2.12	53.8	8.14	206.6	2.38	60.3	4.00	101.6	1.19	30.2	1.35	34.3	7.72	196.1	1.16	29.5	1.35	34.3	0.47	12.5
	MRB41	2.34	59.5	8.36	212.3	2.59	65.9	5.00	127.0	0.82	20.8	0.98	24.9	10.63	270.0	0.79	20.1	0.98	24.9	0.10	3.1
	MRB42	2.34	59.5	8.36	212.3	2.59	65.9	5.00	127.0	0.82	20.8	0.98	24.9	11.63	295.4	0.79	20.1	0.98	24.9	0.10	3.1



BCS/MCS20 ACME SCREW SPECIFICATIONS

CRITICAL SPEED WITH 3/4" ENGLISH ACME SCREW

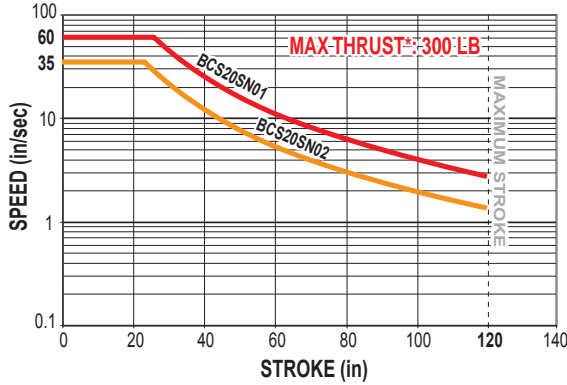

CRITICAL SPEED WITH 19mm METRIC ACME SCREW

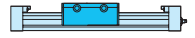
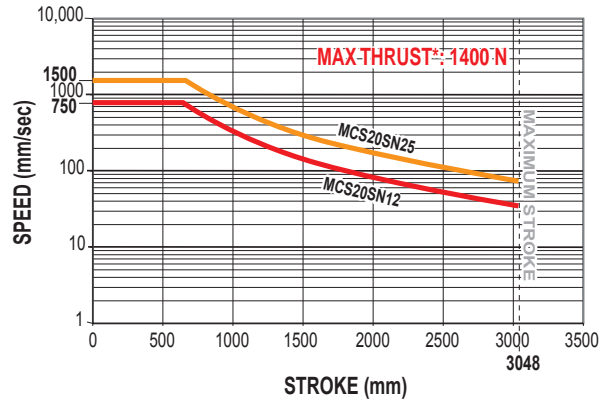

RODLESS

BCS/MCS20 Series

- Acme screw critical speed capacities and PV limits

PV LIMITS: 3/4" 1TPI ENGLISH ACME SCREW

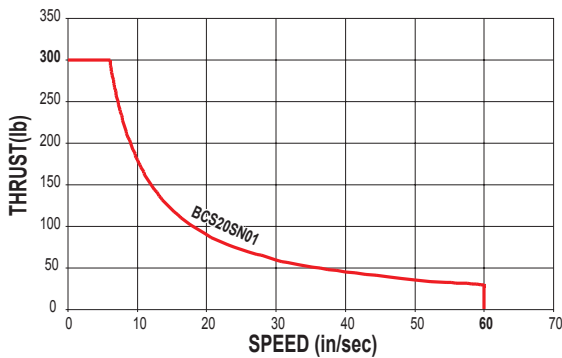

PV LIMITS: 19mm METRIC ACME SCREW w/25mm LEAD

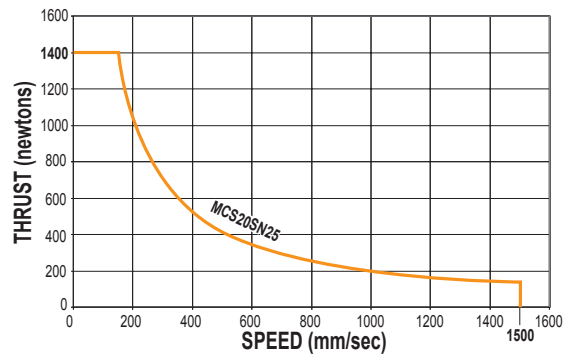

PV LIMITS: 3/4" 2TPI ENGLISH ACME SCREW

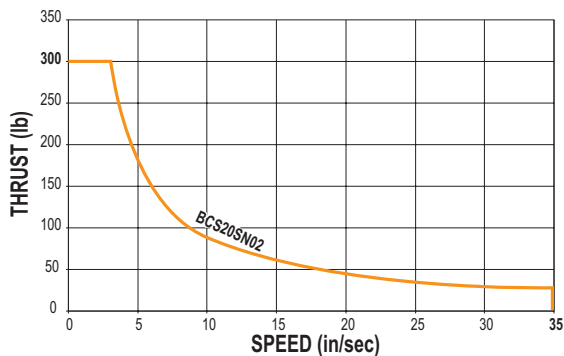

PV LIMITS: 19mm METRIC ACME SCREW w/12mm LEAD

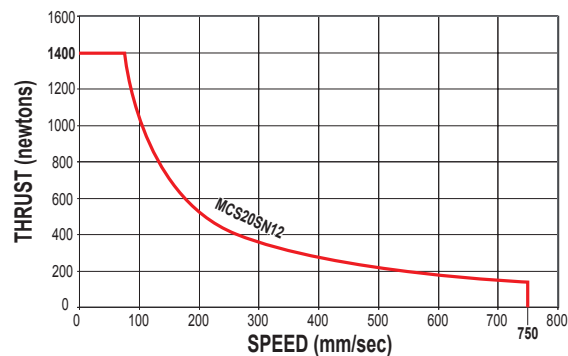

SN = Solid Nut

SNA = Solid Anti-backlash Nut



**Maximum thrust is the maximum continuous dynamic thrust subject to Thrust x Velocity limitation.*

PV LIMITS: Any material which carries a sliding load is limited by heat buildup. The factors that affect heat generation rate in an application are the pressure on the nut in pounds per square inch and the surface velocity in feet per minute. The product of these factors provides a measure of the severity of an application.

$$P = \frac{\text{Thrust}}{\text{Max. Thrust Rating}} \times V = \frac{\text{Speed}}{\text{Max. Speed Rating}} \leq 0.1$$

Axi-dyne® BCS/MCS20 Series BALL SCREW SPECIFICATIONS

BCS20/MCS20 BALL SCREW SPECIFICATIONS

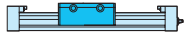

RODLESS

BCS/MCS20 Series

- Ball screw critical speed capacities and life calculations

CRITICAL SPEED WITH 3/4" ENGLISH BALL SCREW, 2TPI

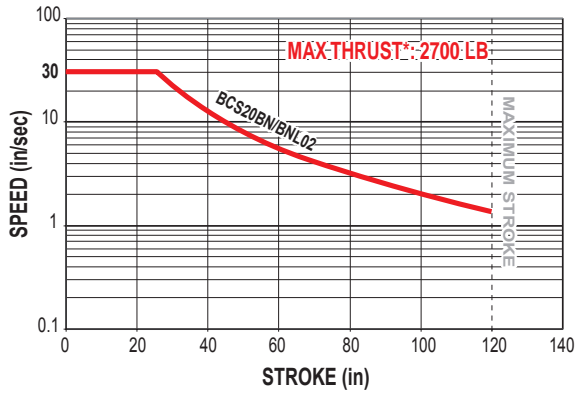

LIFE CALCULATION: 3/4" ENGLISH BALL SCREW, 5TPI

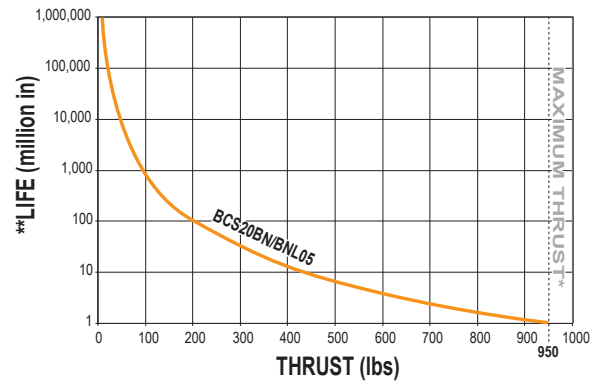

LIFE CALCULATION: 3/4" ENGLISH BALL SCREW, 2TPI

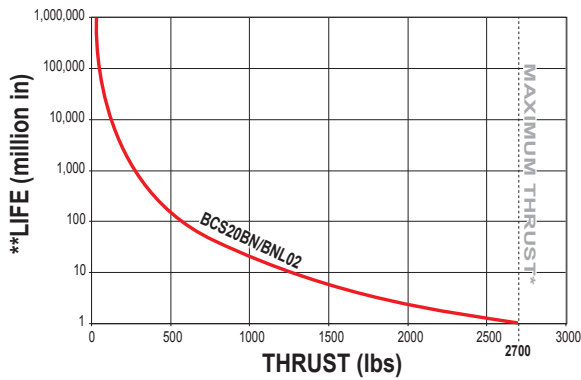

CRITICAL SPEED WITH 20mm METRIC BALL SCREW

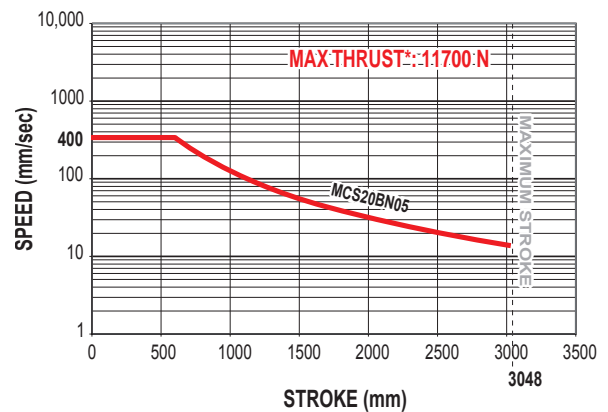

CRITICAL SPEED WITH 3/4" ENGLISH BALL SCREW, 5TPI

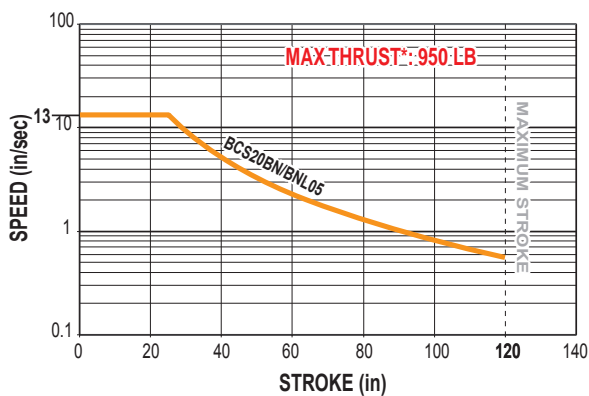

LIFE CALCULATION: 20mm METRIC BALL SCREW w/5mm LEAD

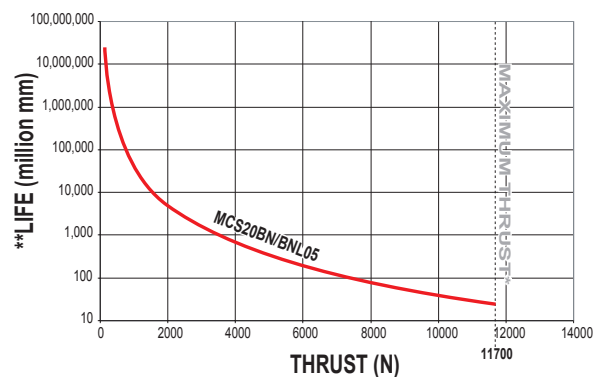

BN = Ball Nut

BNL = Ball Nut with Low-Backlash



*Maximum thrust reflects 90% reliability for 1 million linear inches of travel.

**Life indicates theoretical maximum life of screw only, under ideal conditions and does not indicate expected life of actuator.

Axi-dyne® BCS/MCS20 Series

DIMENSIONS

BCS20 ACTUATOR AND OPTIONS

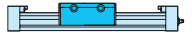
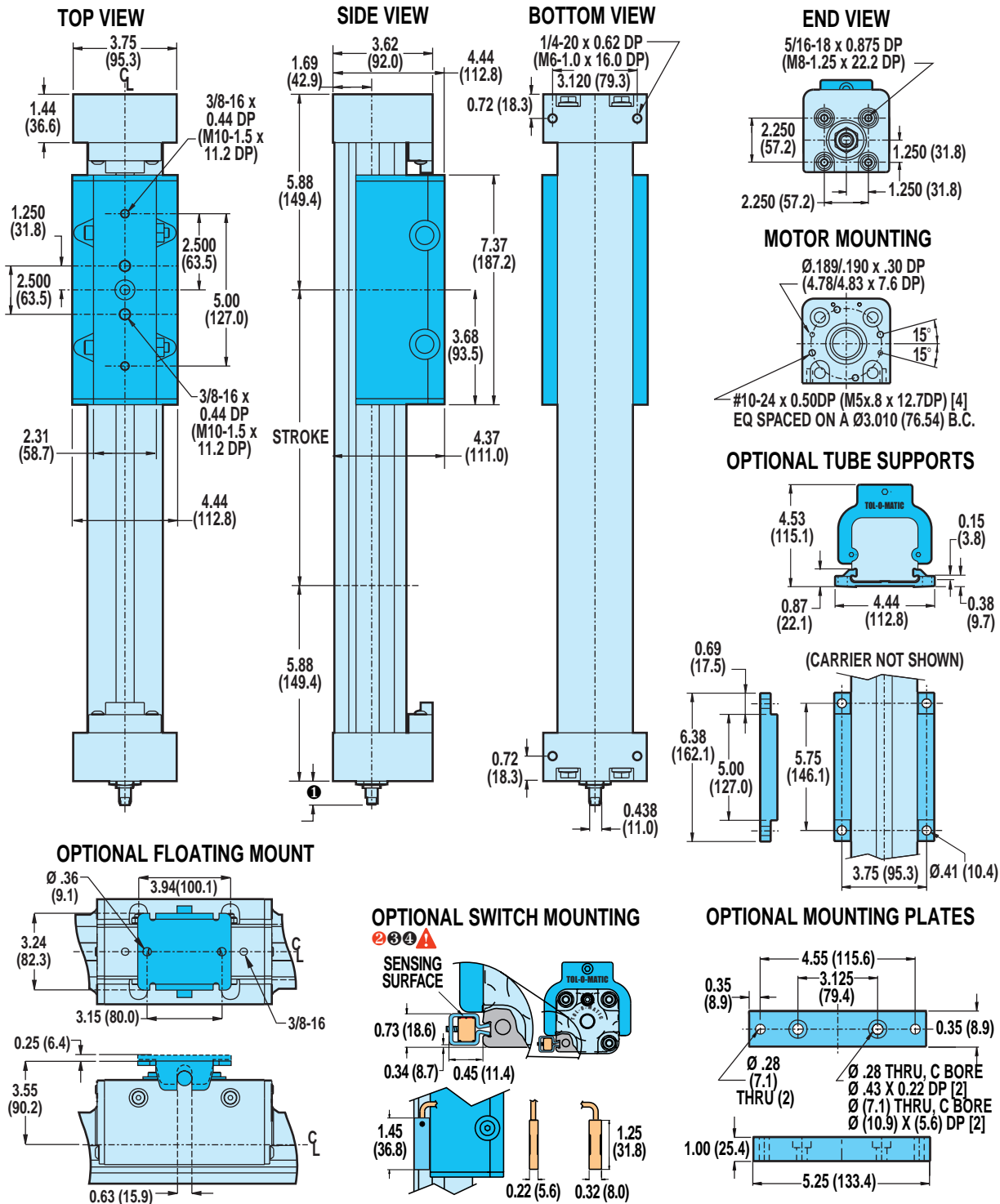

RODLESS

BCS/MCS20 Series
 • Actuator and option dimensions

① SHAFT LENGTH

In-line mounting	0.78 (19.8)
Extended shaft for RP & 23-frame motor	1.95 (49.5)
Extended shaft for RP & 34-frame motor	2.16 (54.9)
Extended shaft for RP & 40-frame motor	2.31 (58.7)
Extended shaft for purchases prior to 6/24/02	2.28 (57.9)

⚠ CAUTION: DO NOT OVERTIGHTEN SWITCH HARDWARE WHEN INSTALLING

Ⓜ NOTE: The scored face of the switch indicates the sensing surface and must face toward the magnet

④ NOTE: Some actuators require switch mounting on a specific side of the actuator. Call Tol-O-Matic 1-800-328-2174 for details

Unless otherwise noted, all dimensions shown are in inches (Dimensions in parenthesis are in millimeters)

Axi-dyne® BCS/MCS20 Series

DIMENSIONS

BCS/MCS20: IN-LINE MOUNT FOR 23-FRAME STEPPER (MRS) OR BRUSHED DC (MRB) MOTORS (Not for use with gearhead reduction)

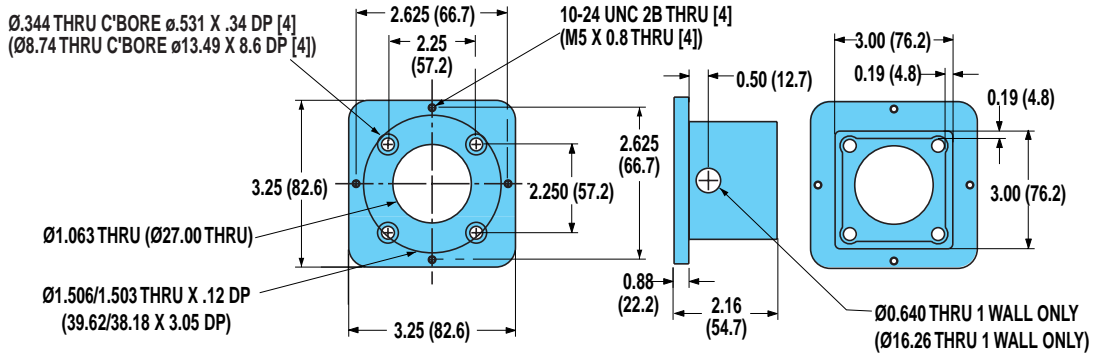

BCS/MCS20: IN-LINE MOUNT FOR 34-FRAME STEPPER (MRS) OR BRUSHED DC (MRB) MOTORS (Not for use with gearhead reduction)

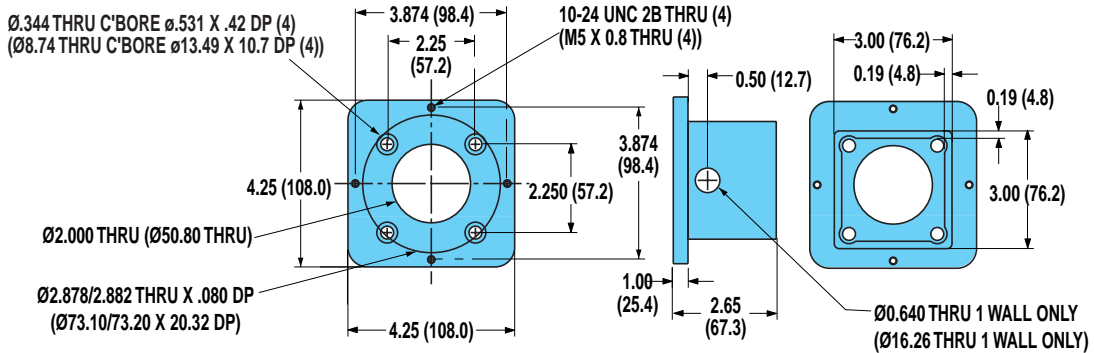

BCS/MCS20: IN-LINE MOUNT FOR BRUSHLESS SERVO (MRV) MOTORS, BRUSHED DC (MRB41,42) MOTORS OR GEARHEADS

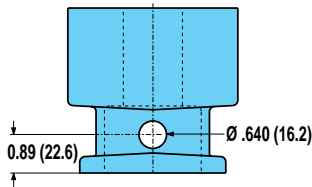

MOTORS KEY

A → MRV3x, MRB3x
 B → MRV2x
 C → GHK20x, GHJ20x, GHJ21x
 GHJ30x, GHJ31x, GHK30
 D → MRB4x



For a complete part listing of screw-drive motor and gearhead mounting kits referencing actuator/motor/coupler compatibilities, refer to document 3600-4631 available on the Literature/Part Sheet/Axi-dyne section of our web site at www.tolomatic.com.

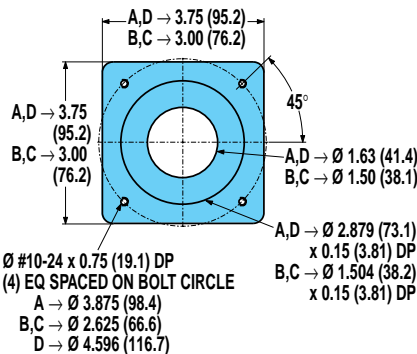
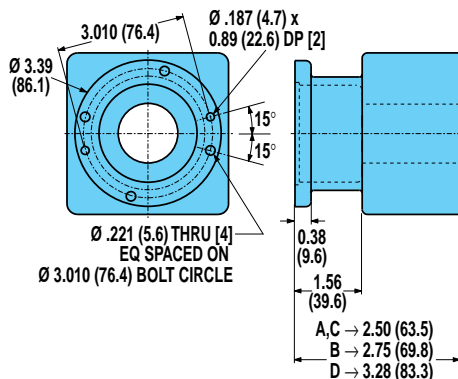

For gearhead dimensions and specifications, refer to page F-10.

Axi-dyne® BCS/MCS20 Series

DIMENSIONS

BCS/MCS20: REVERSE PARALLEL MOUNTING

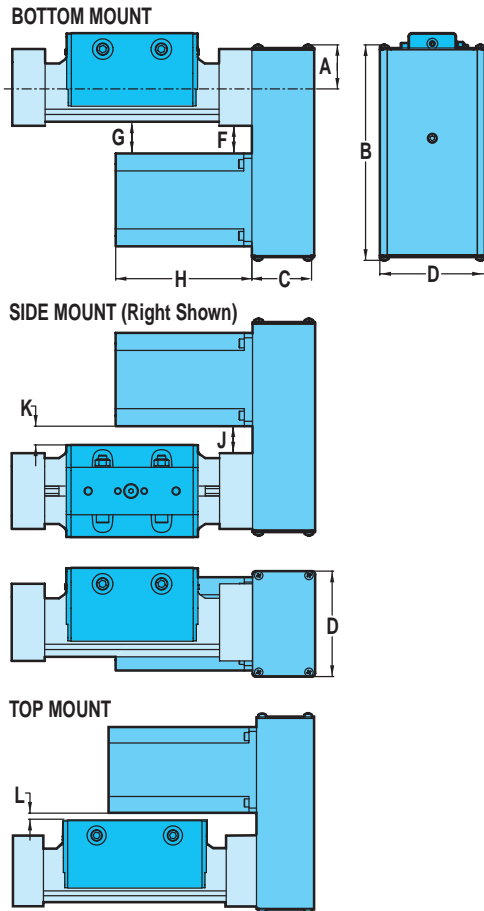

SPECIFICATIONS

MOTOR	WEIGHT OF REDUCTION DRIVE				REDUCTION INERTIA AT MOTOR SHAFT			
	1:1		2:1		1:1		2:1	
	lbs	kg	lbs	kg	lb-in ²	kg-m ² x 10 ⁻⁶	lb-in ²	kg-m ² x 10 ⁻⁶
BRUSHLESS MRV21, 22, 23, 24	3.11	1.41	3.27	1.48	0.154	45.05	0.129	37.73
BRV31, 32, 33	3.18	1.44	3.34	1.51	0.154	45.05	0.129	37.73
STEPPER MRS231, 232	2.97	1.34	3.13	1.42	0.088	25.74	0.063	18.43
MRS341, 342, 342	3.06	1.39	3.22	1.46	0.091	26.62	0.066	19.31
BRUSHED MRB21	2.93	1.33	3.09	1.40	0.088	25.74	0.063	18.43
MRB31, 32	3.13	1.42	3.29	1.49	0.154	45.05	0.129	37.73
MRB41, 42	4.56	2.07	4.84	2.20	0.204	59.67	0.196	57.33

REDUCTION EFFICIENCY: 0.95

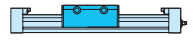

RODLESS

BCS/MCS10 Series

- Reverse parallel mounting

DIMENSIONS

MOTOR	A		B		C		D		F		G		H		J		K		L		
	in.	mm	in.	mm	in.	mm	in.	mm	in.	mm	in.	mm	in.	mm	in.	mm	in.	mm	in.	mm	
BRUSHLESS	MRV21	1.44	36.6	9.31	236.5	2.38	60.3	4.00	101.6	2.44	61.8	2.50	63.5	4.75	120.7	2.25	57.2	2.56	65.0	1.38	34.9
	MRV22	1.44	36.6	9.31	236.5	2.38	60.3	4.00	101.6	2.44	61.8	2.50	63.5	5.75	146.1	2.25	57.2	2.56	65.0	1.38	34.9
	MRV23	1.44	36.6	9.31	236.5	2.38	60.3	4.00	101.6	2.44	61.8	2.50	63.5	6.75	171.5	2.25	57.2	2.56	65.0	1.38	34.9
	MRV24	1.44	36.6	9.31	236.5	2.38	60.3	4.00	101.6	2.44	61.8	2.50	63.5	7.75	196.9	2.25	57.2	2.56	65.0	1.38	34.9
STEPPER	MRV31	1.96	49.7	9.83	249.6	2.38	60.3	4.00	101.6	1.79	45.5	1.86	47.2	6.11	155.2	1.61	40.9	1.92	48.8	0.73	18.5
	MRV32	1.96	49.7	9.83	249.6	2.38	60.3	4.00	101.6	1.79	45.5	1.86	47.2	7.36	186.9	1.61	40.9	1.92	48.8	0.73	18.5
	MRV33	1.96	49.7	9.83	249.6	2.38	60.3	4.00	101.6	1.79	45.5	1.86	47.2	8.61	218.7	1.61	40.9	1.92	48.8	0.73	18.5
	MRS231	1.44	36.6	9.31	236.5	2.38	60.3	4.00	101.6	2.44	61.8	2.50	63.5	2.06	52.3	2.25	57.2	2.56	65.0	1.38	34.9
BRUSHED	MRS232	1.44	36.6	9.31	236.5	2.38	60.3	4.00	101.6	2.44	61.8	2.50	63.5	3.10	78.7	2.25	57.2	2.56	65.0	1.38	34.9
	MRS341	1.96	49.7	9.83	249.6	2.38	60.3	4.00	101.6	1.87	47.5	1.94	49.3	2.58	65.5	1.69	42.9	2.00	50.8	0.81	20.6
	MRS342	1.96	49.7	9.83	249.6	2.38	60.3	4.00	101.6	1.87	47.5	1.94	49.3	3.76	95.5	1.69	42.9	2.00	50.8	0.81	20.6
	MRS343	1.96	49.7	9.83	249.6	2.38	60.3	4.00	101.6	1.87	47.5	1.94	49.3	5.06	128.5	1.69	42.9	2.00	50.8	0.81	20.6
MRB21	1.44	36.6	9.31	236.5	2.38	60.3	4.00	101.6	2.44	61.8	2.50	63.5	6.33	160.8	2.25	57.2	2.56	65.0	1.38	34.9	
MRB31	1.96	49.7	9.83	249.6	2.38	60.3	4.00	101.6	1.93	49.0	2.00	50.8	5.07	128.8	1.75	44.5	2.06	52.3	0.87	22.1	
MRB32	1.96	49.7	9.83	249.6	2.38	60.3	4.00	101.6	1.93	49.0	2.00	50.8	7.72	196.1	1.75	44.5	2.06	52.3	0.87	22.1	
MRB41	2.34	59.5	10.21	259.4	2.59	65.9	5.00	127.0	1.56	39.6	1.63	41.4	10.63	270.0	1.38	35.1	1.69	42.9	0.50	12.7	
MRB42	2.34	59.5	10.21	259.4	2.59	65.9	5.00	127.0	1.56	39.6	1.63	41.4	11.63	295.4	1.38	35.1	1.69	42.9	0.50	12.7	

Axi-dyne® BCS/MCS Screw Drives

ORDERING

BASE MODEL SPECIFICATIONS OPTIONS SPECIFICATIONS

BCS **20** **BN02** **SK45** **RPL1** **DC18** **KT2** **MP4**

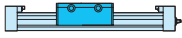

RODLESS

BCS/MCS Series

- Ordering

MODEL TYPE

BCS BCS Series English Screw Drive
MCS MCS Series Metric Screw Drive

TUBE BORE DIAMETER

10 1-inch (25 mm) bore
15 1-1/2-inch (40 mm) bore
20 2-inch (50 mm) bore

NUT/SCREW CONFIGURATION

ENGLISH MODELS

SOLID NUT / PITCH (turn/in)	SERIES
SN01	BCS10, 15, 20
SN02	BCS10, 15, 20
SNA02	BCS10, 15
SN05	BCS10, 15

BALL NUT / PITCH (turn/in)	SERIES
BN02	BCS15, 20
BNL02	BCS15, 20
BN05	BCS15, 20
BNL05	BCS15, 20
BN08	BCS10
BNL08	B3S10

METRIC MODELS

SOLID NUT / LEAD (mm/turn)	SERIES
SN12	MCS10, 15, 20
SN25	MCS10, 15, 20

BALL NUT / LEAD (mm/turn)	SERIES
BN02	MCS10
BNL02	MCS10
BN05	MCS15, 20
BNL05	MCS15, 20

STROKE LENGTH

SK Stroke, then enter desired stroke length in decimal inches

MOTOR MOUNTING / REDUCTIONS

(must choose one)

LMI In-Line mounting
LME23 Ext. shaft for RP & 23 frame motor
LME34 Ext. shaft for RP & 34 frame motor
LME40 Ext. shaft for RP & 40 frame motor
****LMX** Extended shaft - old style (see note)
****For replacement actuators with extended motor shafts purchased prior to 6/24/02 use LMX**

▲ A motor size and code must be selected when specifying a reverse-parallel mounting configuration. Reference the ordering pages in sections F, G and H for the motor types and selections.

RPL1 1:1 Reverse-Parallel mount left
RPR1 1:1 Reverse-Parallel mount right
RPB1 1:1 Reverse-Parallel mount bottom
RPT1 1:1 Reverse-Parallel mount top
RPL2 2:1 Reverse-Parallel mount left
RPR2 2:1 Reverse-Parallel mount right
RPB2 2:1 Reverse-Parallel mount bottom
RPT2 2:1 Reverse-Parallel mount top

AUXILIARY CARRIER

DC_ Auxiliary Carrier, then center-to-center spacing desired in decimal inches. (Center-to-Center spacing will add to overall dead length and will not subtract from the stroke length)

SWITCHES

RM_ Reed Switch (Form A) with 5-meter lead/QD, and quantity desired
RT_ Reed Switch (Form A) with 5-meter lead, and quantity desired
BM_ Reed Switch (Form C) with 5-meter lead/QD, and quantity desired
BT_ Reed Switch (Form C) with 5-meter lead, and quantity desired
KM_ Hall-effect Sinking Switch with 5-meter lead/QD, and quantity desired
KT_ Hall-effect Sinking Switch with 5-meter lead, and quantity desired
TM_ Hall-effect Sourcing Switch with 5-meter lead/QD, and quantity desired
TT_ Hall-effect Sourcing Switch with 5-meter lead, and quantity desired
CM_ TRIAC Switch with 5-meter lead/QD, and quantity desired
CT_ TRIAC Switch with 5-meter lead, and quantity desired

TO ORDER MOTORS/CONTROLS/INTERFACES

BRUSHLESS SERVO (SEE PAGE F-33)

MICROSTEPPING (SEE PAGE G-23)

BRUSHED DC (SEE PAGE H-26)

SUPPORTS AND MOUNTING PLATES

(both may be selected)

TS_ Tube Supports plus quantity desired
MP_ Mounting Plates plus quantity desired

▲ Not all codes listed are compatible with all options.

Use the Tol-O-Motion™ Sizing Software to determine available options and accessories based on your application requirements.

FIELD RETROFIT KITS

ITEM	B3S10	B3S15	B3S20	M3S10	M3S15	M3S20
Tube Supports	4510-1010	4515-1010	4520-1010	4510-1010	4515-1010	4520-1010
Mounting Plates	0910-9133	0915-9135	0920-9038	0510-9105	0515-9138	0520-9105

Axi-dyne® SLS/MLS Screw Drives

OVERVIEW



APPLICATION BENEFITS

- Rigid, low-profile design is ideal for space-sensitive applications
- Consistent carrier tracking and long actuator life
- Wide base for ease of mounting.

GUIDANCE SYSTEM



Pre-engineered and fully enclosed the SLS slide guidance system consists of recirculating bearings on ground steel shafts, offering stability and endurance.



Uses the same patented Band Retention system as the BCS—a T-shaped elastomer strip bonded to a stainless steel band, inserted directly into the body housing forming a tight metal-to-metal seal for clean operation.

STANDARD MOUNTING



Actuators are provided with T-nuts in the base of the cylinder body. Four T-nuts for the first 24 inches of stroke are standard. Two nuts are provided for each additional 20 inches of stroke. The SLS tube and work table accept 1/4" threaded square nuts (MLS, M6 threaded square nuts).

ACTUATOR/MOTOR FACTORS

- Actuator's operating temperature range (40-130° F, 4-54° C) should take into consideration heat generated by the motor and drive, linear velocity and work cycle time.
- For large frame motors or small actuators, cantilevered motors need to be supported, if subjected to continuous rapid reversing duty and/or under dynamic conditions.

AVAILABLE OPTIONS



Mounting Plates: Provide clearance height for motors and motor mounts when mounting an actuator on a flush surface. Mount to either tapped holes in cylinder heads or to T-nuts, they provide the means for top mounting access. Kits include plates and mounting screws.



Auxiliary Carrier: Increases rigidity, load-carrying capacity and bending moments



Motor Mounting and Gearhead Reduction:

In-line Motor Mounting—This motor mounting option uses a spacer and coupler to join the motor to the actuator shaft.



Gearhead Reduction—Gearheads are available for applications requiring reduction for inertia matching or higher torque at lower speeds. High efficiency, single stage, true planetary gearheads are available in 5.5:1 and 10:1 ratios for reduction solutions with most Tol-O-Matic NEMA 23 and 34 face motors. For gearhead specifications and dimensions, see page F-10.



Switches: Reed, dc Hall-effect and ac TRIAC. See section I.

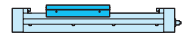

RODLESS

SLS/MLS Series

- Application benefits
- Guidance system
- Standard mounting
- Actuator/motor factors
- Available options

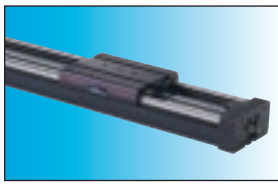

Axi
dyne[®]

SLS/MLS10 Series ACME SCREW SPECIFICATIONS

SLS/MLS10 ACME SCREW CRITICAL SPEED AND PV LIMITS

CRITICAL SPEED WITH 1/2" ENGLISH ACME SCREW

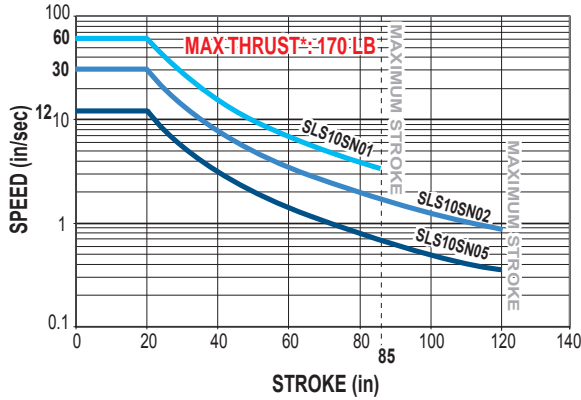

CRITICAL SPEED WITH 12mm METRIC ACME SCREW

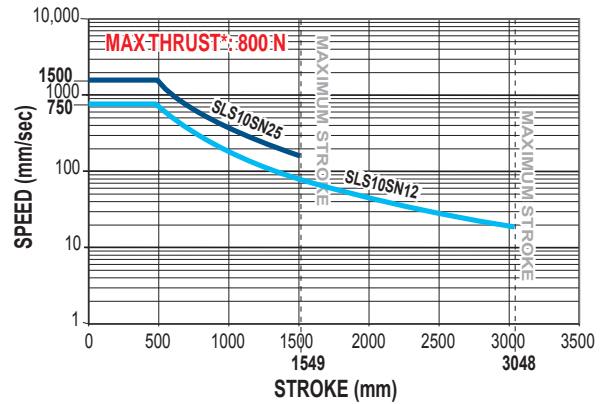

PV LIMITS: 1/2" 1 TPI ENGLISH ACME SCREW

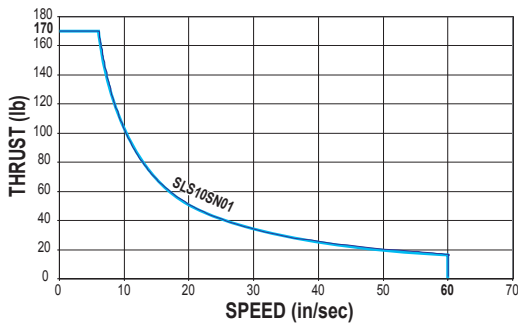

PV LIMITS: 12mm ACME METRIC SCREW w/25mm LEAD

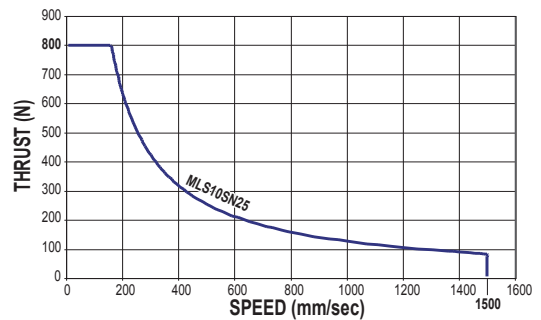

PV LIMITS: 1/2" 2 TPI ENGLISH ACME SCREW

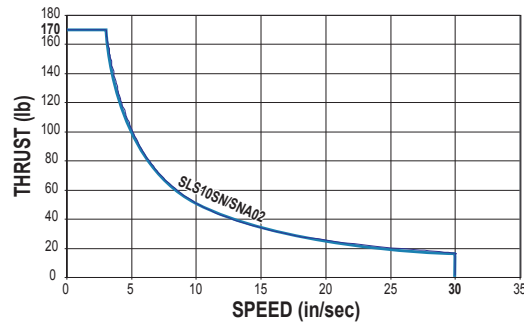

PV LIMITS: 12mm ACME METRIC SCREW w/12mm LEAD

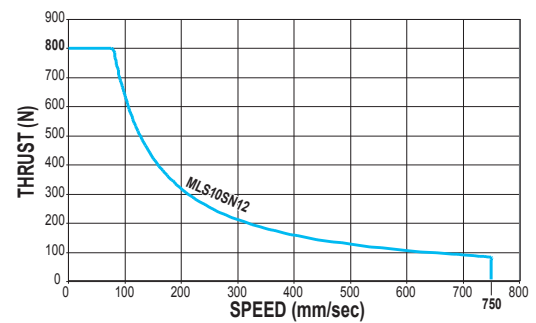

PV LIMITS: 1/2" 5 TPI ENGLISH ACME SCREW

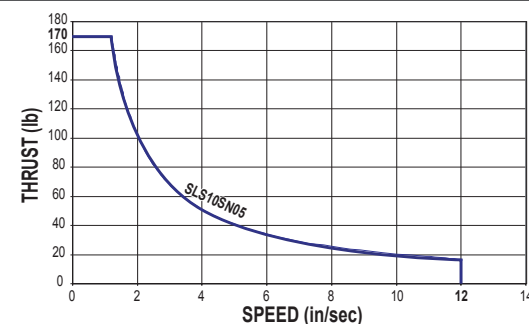

SN = Solid Nut

SNA = Solid Anti-backlash Nut

⚠ *Maximum thrust is the maximum continuous dynamic thrust subject to Thrust x Velocity limitation.

PV LIMITS: Any material which carries a sliding load is limited by heat buildup. The factors that affect heat generation rate in an application are the pressure on the nut in pounds per square inch and the surface velocity in feet per minute. The product of these factors provides a measure of the severity of an application.

$$P = \frac{\text{Thrust}}{\text{Max. Thrust Rating}} \times V = \frac{\text{Speed}}{\text{Max. Speed Rating}} \leq 0.1$$

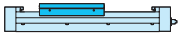

RODLESS

SLS/MLS10 Series

- Acme screw critical speed capacities and PV limits

Axi dyne® SLS/MLS10 Series

BALL SCREW SPECIFICATIONS

SLS/MLS10 BALL SCREW SPECIFICATIONS

CRITICAL SPEED WITH 3/8" ENGLISH BALL SCREW

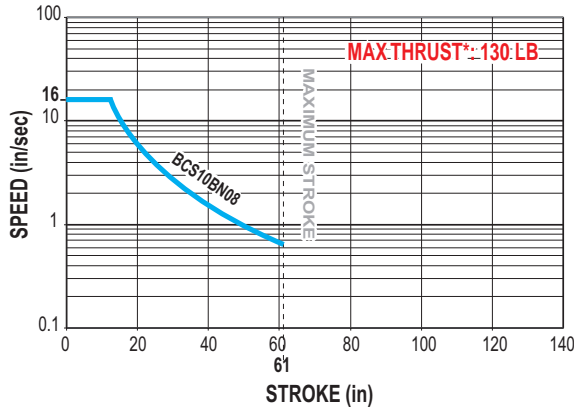

CRITICAL SPEED WITH 10mm METRIC BALL SCREW

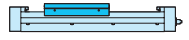
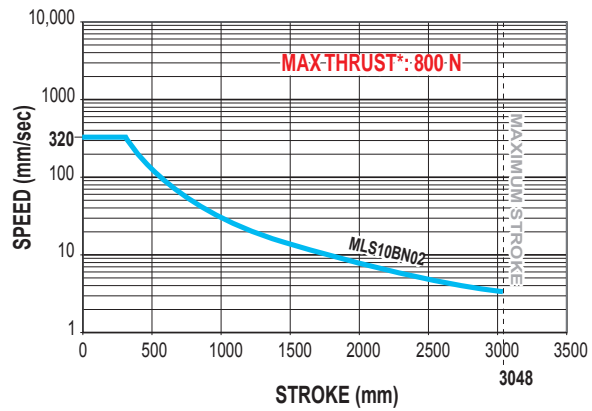

RODLESS

SLS/MLS10 Series

- Ball screw critical speed capacities and life calculations

LIFE CALCULATION: 3/8" 8TPI ENGLISH BALL SCREW

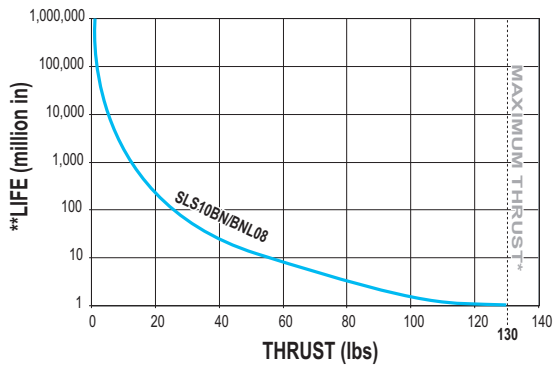

LIFE CALCULATION: 10mm METRIC BALL SCREW w/2.5mm LEAD

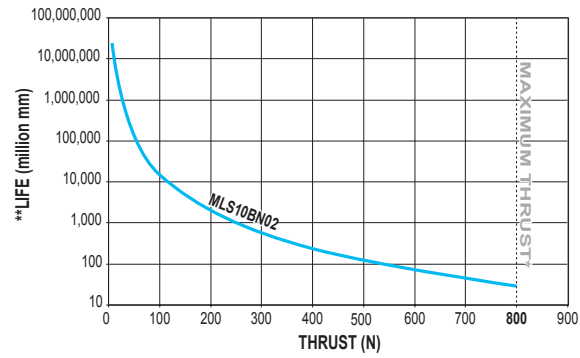

BN = Ball Nut



** Maximum thrust reflects 90% reliability for 1 million linear inches of travel.*

***Life indicates theoretical maximum life of screw only, under ideal conditions and does not indicate expected life of actuator.*

Axi dyne® SLS/MLS10 Series

SPECIFICATIONS

SPECIFICATIONS RELATED TO ACTUATOR SIZE AND SCREW SELECTION

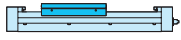

RODLESS

SLS/MLS10 Series

- Actuator and screw specifications

ENGLISH LEAD SCREWS										
ACTUATOR SERIES	SCREW DIA. (in)	SCREW TYPE	TPI (turns/in)	LEAD ACCURACY (in/ft)	BACKLASH (in)	MAXIMUM THRUST* (lb)	MAXIMUM STROKE (in)	INERTIA (lb-in ²)		BREAKAWAY TORQUE (lb-in)
								BASE ACTUATOR	PER/in	
								In Line	OF STROKE	
SLS10	0.375	BN	08	0.004	0.015	130	61	0.0054	0.0005	1.063
	0.375	BNL	08	0.004	0.002	130	61	0.0054	0.0005	1.063
	0.500	SN	01	0.006	0.007	170	85	0.0554	0.0017	1.875
	0.500	SN	02	0.005	0.007	170	120	0.0262	0.0017	1.438
	0.500	SNA	02	0.005	0.003	170	120	0.0262	0.0017	1.438
	0.500	SN	05	0.006	0.007	170	120	0.0180	0.0017	1.250

METRIC LEAD SCREWS										
ACTUATOR SERIES	SCREW DIA. (mm)	SCREW TYPE	LEAD (mm/turn)	LEAD ACCURACY (mm/300)	BACKLASH (mm)	MAXIMUM THRUST (N)	MAXIMUM STROKE (mm)	INERTIA (kg-m ² x 10 ⁻⁶)		BREAKAWAY TORQUE (N-m)
								BASE ACTUATOR	PER/mm	
								In Line	OF STROKE	
MCS10	10	BN	2.5	0.13	0.38	800	3048	1.81	0.18	0.17
	10	BNL	2.5	0.13	0.05	800	3048	1.81	0.18	0.17
	12	SN	12	0.13	0.18	800	3048	6.49	0.41	0.17
	12	SN	25	0.13	0.18	800	1626	15.01	0.41	0.17

SCREW CODE	DESCRIPTION
SN	Solid Nut
SNA	Anti-backlash Solid Nut
BN	Ball Nut
BNL	Low-Backlash Ball Nut



Contact the factory for higher accuracy and lower backlash options.
* For Acme screws, maximum thrust is the maximum continuous dynamic thrust subject to Thrust x Velocity limitation. For ball screws, maximum thrust reflects 90% reliability for 1 million linear inches of travel.

GENERAL ACTUATOR SPECIFICATIONS

SLS ENGLISH ACTUATORS					
ACTUATOR SERIES	CARRIER WEIGHT (lb)	BASE WEIGHT (lb) (Including Carrier)	WEIGHT PER/IN OF STROKE (lb)	TEMPERATURE RANGE* (F°)	IP RATING**
SLS10	1.54	6.05	0.404	40 - 130	44

MLS METRIC ACTUATORS					
ACTUATOR SERIES	CARRIER WEIGHT (kg)	BASE WEIGHT (kg) (Including Carrier)	WEIGHT PER/mm OF STROKE (g)	TEMPERATURE RANGE* (C°)	IP RATING**
MLS10	0.69	2.74	7.23	4 - 54	44



* Heat generated by the motor and drive should be taken into consideration as well as linear velocity and work cycle time. For applications that require operation outside of the recommended temperature range, contact the factory.

** Protected against ingress of solid particles greater than .039 in (1mm) and splashing water.

LARGE FRAME MOTORS AND SMALLER SIZE ACTUATORS: Cantilevered motors need to be supported, if subjected to continuous rapid reversing duty and/or under dynamic conditions.

Axi dyne[®] SLS/MLS10 Series

SPECIFICATIONS

FRICITION FORCE

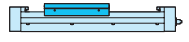
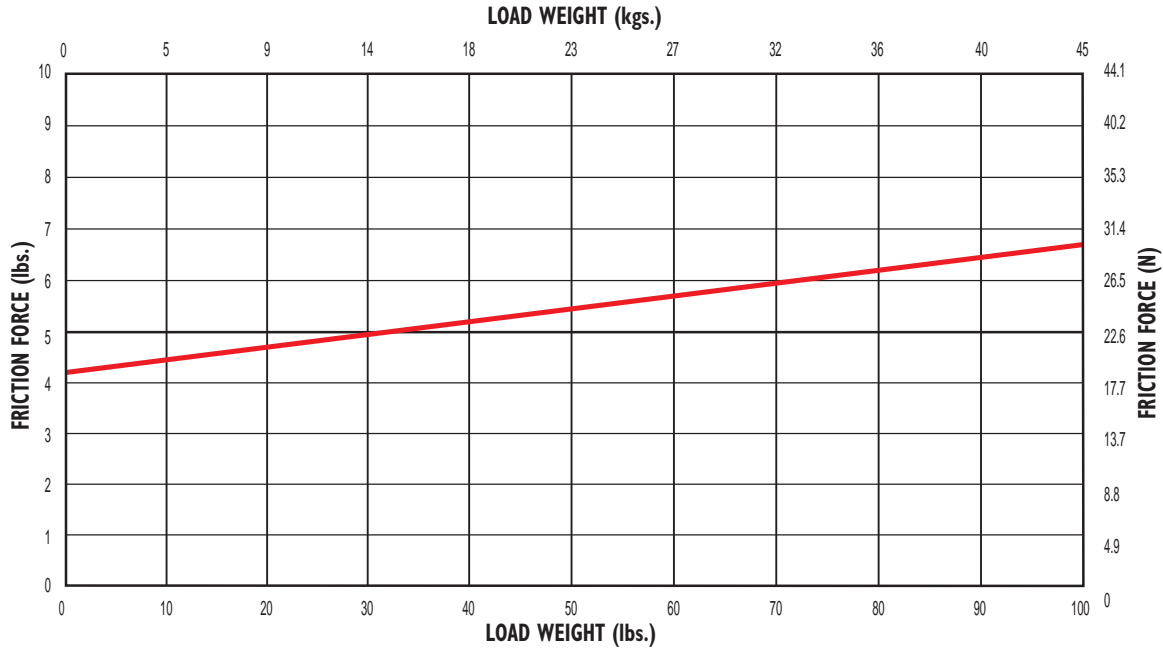

RODLESS

SLS/MLS10 Series

- Friction Force
- Support recommendations
- Bending moments and loads

SUPPORT RECOMMENDATIONS

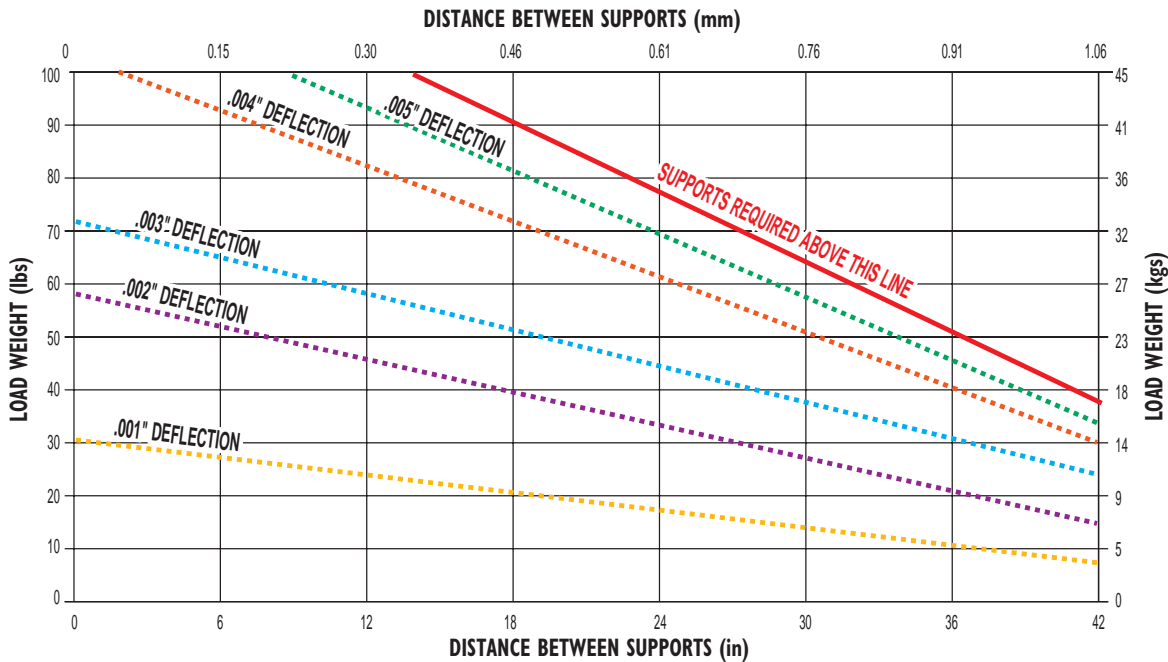

Axi dyne® SLS/MLS10 Series

SPECIFICATIONS

DYNAMIC BENDING MOMENTS AND LOADS

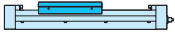

RODLESS

SLS/MLS10 Series

- Bending moments and loads

	MAXIMUM BENDING MOMENTS AND LOADS		ENGLISH	METRIC
STANDARD CARRIER			SLS10	MLS10
	Mx Moment (Roll)	(lb-in : N-m)	80	9.0
	My Moment (Pitch)	(lb-in : N-m)	80	9.0
	Mz Moment (Yaw)	(lb-in : N-m)	125	14.1
	Fz Load (Lateral)	(lb : N)	100	445
AUXILIARY CARRIER: Increases rigidity, load-carrying capacity and moments			SLS10	MLS10
	Mx Moment (Roll)	*(lb-in : N-m)	160	18.1
	My Moment (Pitch)	*(lb-in : N-m)	178	20.1
	Mz Moment (Yaw)	*(lb-in : N-m)	278	31.3
	Fz Load (Lateral)	(lb : N)	200	890
	Minimum Dimension 'D'	(in : mm)	5.5	169.7



Breakaway torque will increase when using the Auxiliary carrier option. When ordering, determine your working stroke and enter this value into the configuration string. Overall actuator length will automatically be calculated.

*Loads shown in table are at minimum "D" dimension, for ratings with longer "D" dimension see graph on page C-135.

Axi-dyne® SLS/MLS10 Series

SPECIFICATIONS

LOAD DEFLECTION

Y-AXIS DEFLECTION

Figures calculated with the following considerations:

- 1.) Tube supports spaced at minimum distances for each bore size
- 2.) Measurement distance from F to center of carrier is 6 inches

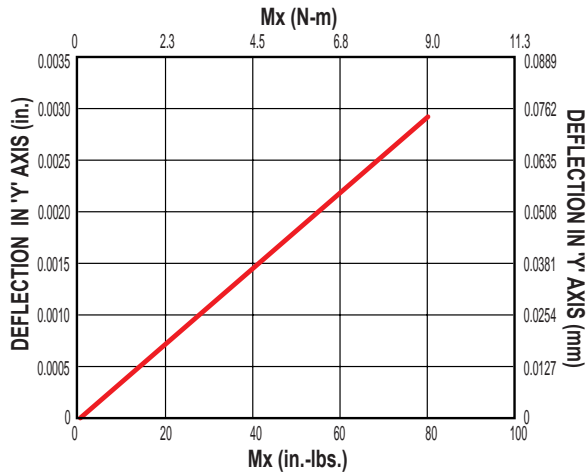
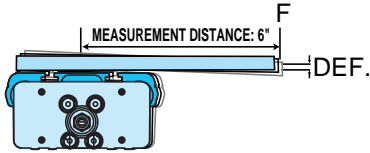

X-AXIS DEFLECTION

Figures calculated with the following considerations:

- 1.) Tube supports spaced at minimum distances for each bore size
- 2.) Measurement distance from F to center of carrier is 6 inches

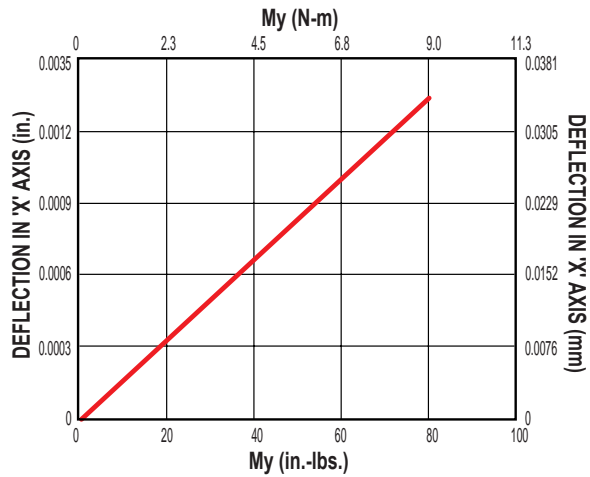
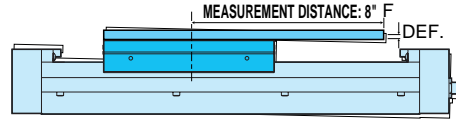

RODLESS

SLS/MLS10 Series

- Load deflection
- Auxiliary carrier

AUXILIARY CARRIER: BENDING MOMENT AT 'D' DISTANCE

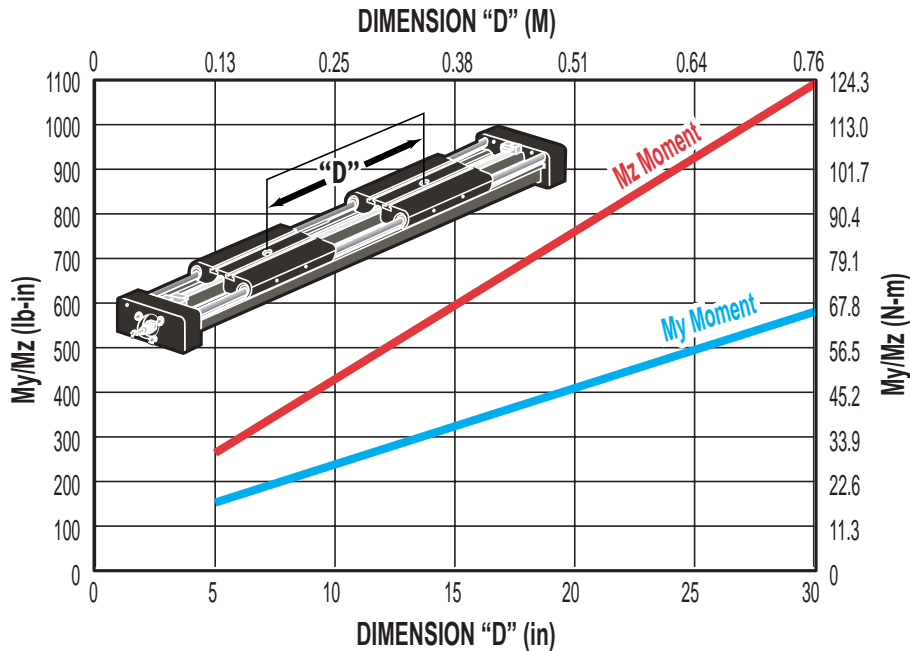

Rates shown on charts were calculated with these assumptions:

- 1.) Coupling between carriers is rigid.
- 2.) Load is equally distributed between carriers.
- 3.) Coupling device applies no misalignment loads to carriers.

* Customer must specify Dimension "D" (Distance between carrier center lines) in configuration string.

Axi dyne® SLS/MLS10 Series

DIMENSIONS

SLS10/MLS10 ACTUATOR AND OPTIONS DIMENSIONS

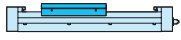

RODLESS

SLS/MLS10 Series

- Actuator and options dimensions

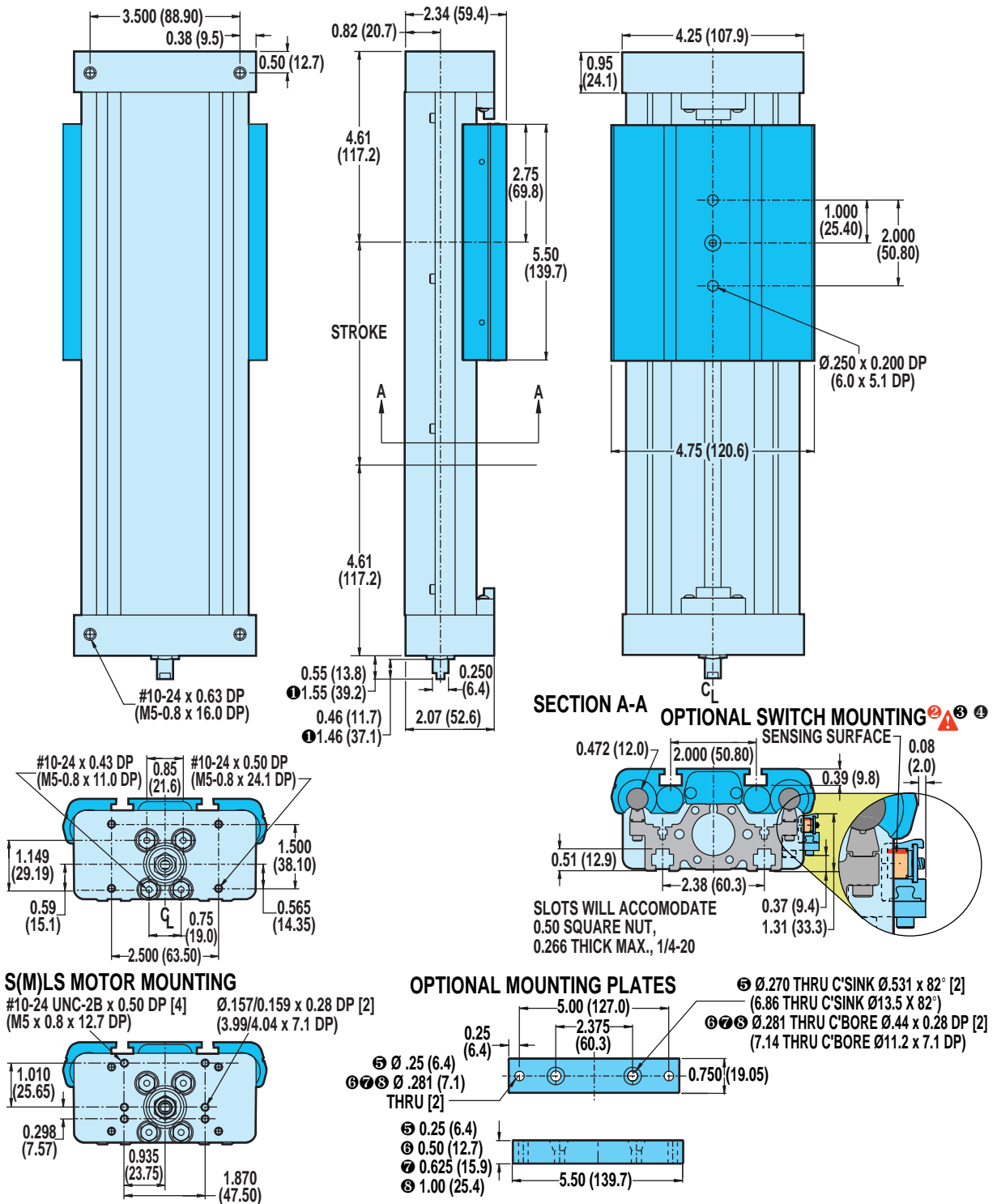

Axi dyne® SLS/MLS10 Series

DIMENSIONS

SLS/MLS10: IN-LINE MOUNT FOR 23-FRAME STEPPER (MRS) OR BRUSHED DC (MRB) MOTORS (Not for use with gearhead reduction)

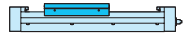
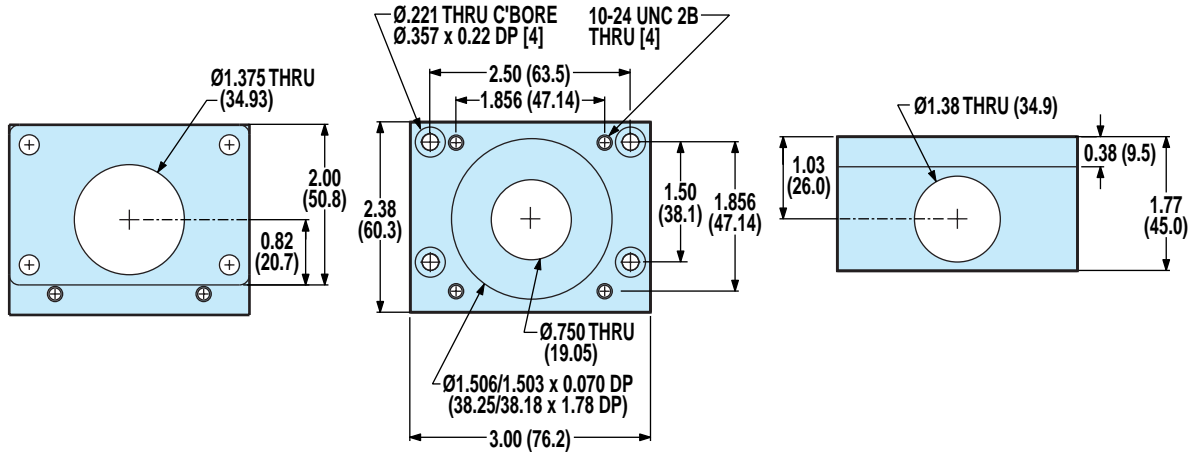

RODLESS

SLS/MLS10 Series

- In-line mounting dimensions

SLS/MLS10: IN-LINE MOUNT FOR 34-FRAME STEPPER (MRS) OR BRUSHED DC (MRB) MOTORS (Not for use with gearhead reduction)

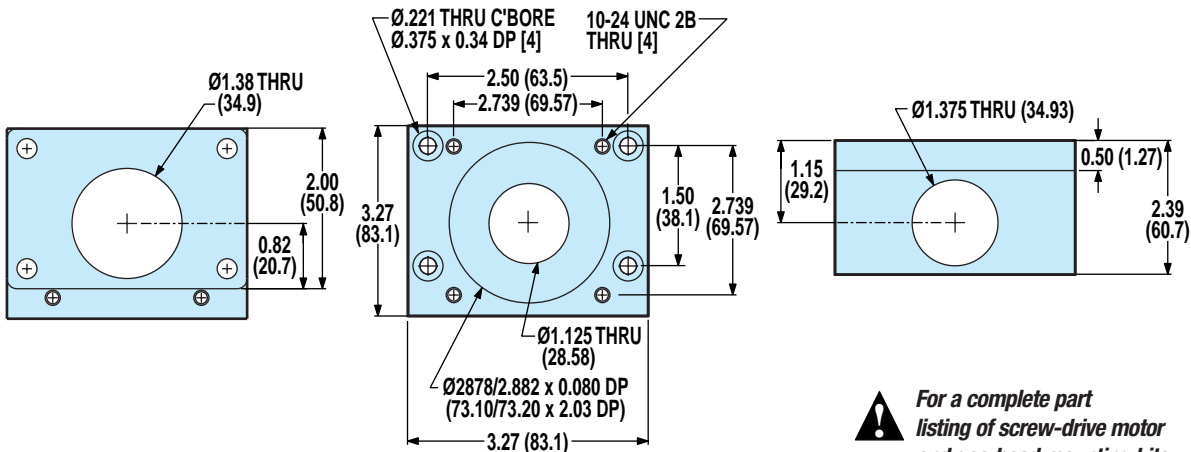

For a complete part listing of screw-drive motor and gearhead mounting kits referencing actuator/motor/coupler compatibilities, refer to document 3600-4631 available on the Literature/Part Sheet/Axidyne section of our web site at: www.tolomatic.com.

For gearhead dimensions and specifications, refer to page F-10.

Axi dyne® SLS/MLS10 Series

ORDERING

BASE MODEL SPECIFICATIONS

SLS 10 SN02 SK25 LMI

OPTIONS SPECIFICATIONS

DC18 KT2 TN4 MP2

MODEL TYPE

SLS SLS Series English Screw Drive
MLS MLS Series Metric Screw Drive

TUBE BORE DIAMETER

10 1-inch (25 mm) bore

NUT/SCREW CONFIGURATION

ENGLISH MODELS

SOLID NUT / PITCH (turn/in)	SERIES
SN01	SLS10
SN02	SLS10
SNA02	SLS10
SN05	SLS10

BALL NUT / PITCH (turn/in)	SERIES
BN08	SLS10
BNL08	SLS10

METRIC MODELS

SOLID NUT / LEAD (mm/turn)	SERIES
SN12	MLS10
SN25	MLS10

BALL NUT / LEAD (mm/turn)	SERIES
BN02	MLS10
BNL02	MLS10

STROKE LENGTH

SK Stroke, then enter desired stroke length in decimal inches

MOTOR MOUNTING / REDUCTIONS

(must choose one)

LMI In-Line mounting
****LMX** Extended shaft - old style (see note)

**** For replacement actuators with extended motor shafts purchased prior to 6/24/02 use LMX**

AUXILIARY CARRIER

DC_ Auxiliary Carrier, then center-to-center spacing desired in decimal inches. (Center-to-Center spacing will add to overall dead length and will not subtract from the stroke length)

SWITCHES

RM_ Reed Switch (Form A) with 5-meter lead/QD, and quantity desired
RT_ Reed Switch (Form A) with 5-meter lead, and quantity desired
BM_ Reed Switch (Form C) with 5-meter lead/QD, and quantity desired
BT_ Reed Switch (Form C) with 5-meter lead, and quantity desired
KM_ Hall-effect Sinking Switch with 5-meter lead/QD, and quantity desired
KT_ Hall-effect Sinking Switch with 5-meter lead, and quantity desired
TM_ Hall-effect Sourcing Switch with 5-meter lead/QD, and quantity desired
TT_ Hall-effect Sourcing Switch with 5-meter lead, and quantity desired
CM_ TRIAC Switch with 5-meter lead/QD, and quantity desired
CT_ TRIAC Switch with 5-meter lead, and quantity desired

T-NUT OPTION

TN_ Additional T-nuts and quantity

MOUNTING PLATES

MP_ Mounting Plates plus quantity desired

⚠ *Not all codes listed are compatible with all options.*

Use the Tol-O-Motion™ Sizing Software to determine available options and accessories based on your application requirements.

TO ORDER MOTORS/CONTROLS/INTERFACES

 **BRUSHLESS SERVO (SEE PAGE F-33)**

 **MICROSTEPPING (SEE PAGE G-23)**

 **BRUSHED DC (SEE PAGE H-26)**

FIELD RETROFIT KITS

ITEM	SLS10	MLS10
1/4" Mounting Plates	0610-9010	0610-9010
1/2" Mounting Plates	0610-9045	0610-9045

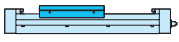

RODLESS

SLS/MLS10 Series

• Ordering

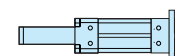

ROD SCREW

RSA/RSM ROD SCREW ACTUATORS

The following pages contain detailed information about Tol-O-Matic rodless actuators. Visit www.tolomatic.com for the latest updates, Tol-O-Motion Sizing Software, CAD files and software support downloads.

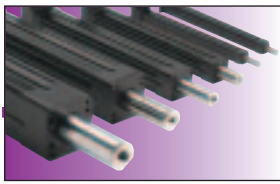

Axi-dyne® RSA/RSM Rod Screw

OVERVIEW

APPLICATION BENEFITS

- Cost-effective choice for short stroke, high thrust applications
- Multiple mounting options for pivotal mounting flexibility
- Used with externally guided and supported loads

ACTUATOR/MOTOR FACTORS

- Actuator's operating temperature range (40-130° F, 4-54° C) should take into consideration heat generated by the motor and drive, linear velocity and work cycle time.
- For large frame motors or small actuators, cantilevered motors need to be supported, if subjected to continuous rapid reversing duty and/or under dynamic conditions.
- Rod screw actuators are designed to push guided and supported loads and are not meant for applications that require substantial side loading. Please contact the factory for details regarding side loading capabilities.

STANDARD MOUNTING



Mounting holes are provided on the underside of the actuator. and rod ends are internally threaded.

MOTOR MOUNTING



RSA rod screw actuators are configured as an in-line base model or a reverse-parallel base model.

In-line Motor Mounting— motor is internally coupled to the actuator shaft.

Reverse-parallel Motor Mounting—These factory assembled configurations allow offset mounting of the motor to either side of, or below the actuator. Available in a 1:1 drive ratio on RSA12 and 16 series or 1:1 and 2:1 drive ratios for the RSA24, 32, 50 and 64 series, they offer quiet, zero-backlash coupling of the motor to the actuator screw shaft.

GEARHEAD REDUCTION



Gearheads are available for applications requiring reduction for inertia matching or higher torque at lower speeds. High efficiency, single stage, true planetary gearheads are available for the RSA24, 32, 50 and 64 series in 5.5:1 and 10:1 ratios for reduction solutions with most Tol-O-Matic NEMA 23- and 34-frame motors. For gearhead specifications and dimensions, see page F-10 for details.

OPTIONAL ROD EXTENSION

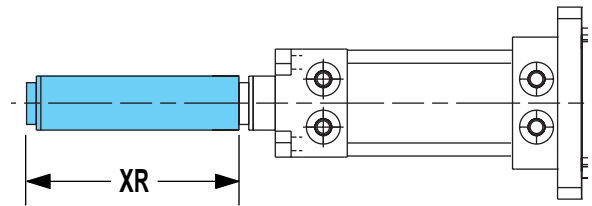

In vertical applications, the rod screw actuator reach can be extended by specifying the rod extension option. This does not extend the stroke length, only the rod length.

⚠ *The XR dimension in the configuration string (extension + stroke) should not exceed the maximum stroke of the specified actuator. Consult the factory for extensions greater than the maximum stroke length.*

MAXIMUM STROKE (in)		MAXIMUM STROKE (mm)	
RSA12	12	RSM12	305
RSA16	18	RSM16	457
RSA24	24	RSM24	610
RSA32	36	RSM32	914
RSA50	48	RSM50	1,219
RSA64	60	RSM64	1,524

SWITCHES



Switches: Reed, dc Hall-effect and ac TRIAC.
See page I-1.

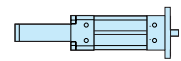

ROD SCREW

RSA/RSM Series

- Application benefits
- Actuator/motor factors
- Standard mounting
- Motor mounting
- Gearhead reduction
- Rod Extension
- Switches

Axi dyne® RSA/RSM Rod Screw

OVERVIEW

MOUNTING OPTIONS

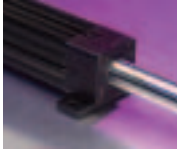

Mounting Plates – used when mounting holes on bottom of actuator are not accessible.

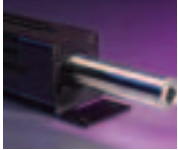

Foot Mount – used for mountings other than flush.



Front and Back Flange Mounts – used when a bottom-tapped mount is not an option or where bottom support mechanisms are not feasible. Flange can be mounted directly to framework or a bulkhead.



Clevis and Eye Mounts – used when the actuator has to compensate for misalignment or pivot about an access when free movement is available in the back of the actuator. Clevis and eye mounts are only available on reverse parallel models.



Trunnion Mount – used where space is limited in the rear of the actuator and when pivoting about an access is required.

ROD END OPTIONS



Externally Threaded Rod End – an alternative to the standard internally threaded end.



Clevis Rod End – used with the externally threaded rod end when the actuator has to compensate for misalignment or pivot about an access.



Spherical Rod Eye – allows for slight misalignment between the load and the actuator (radial and angular). Uses an industry-standard bearing.



Alignment Coupler – used in combination with the externally threaded rod end to provide smooth motion and extend actuator life by preventing binding caused by angular or axial misalignment. Not available for use with clevis or trunnion mounts, as they must be rigidly mounted.

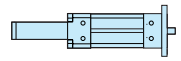

ROD SCREW

RSA/RSM Series

- Mounting options
- Rod end options

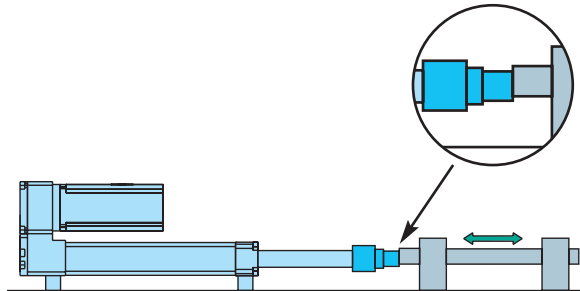

The alignment coupler requires the use of the MET external rod end option.

Axi dyne® RSA/RSM Rod Screw

ACME SCREW/NUT COMBINATIONS

ACME SCREW CRITICAL SPEED CAPACITIES

RSA/RSM12, 16, 24, 32: CRITICAL SPEED WITH ENGLISH ACME SCREW

RSA/RSM50, 64: CRITICAL SPEED WITH ENGLISH ACME SCREW

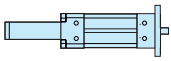

ROD SCREW

RSA/RSM Series

- Acme screw critical speed capacities

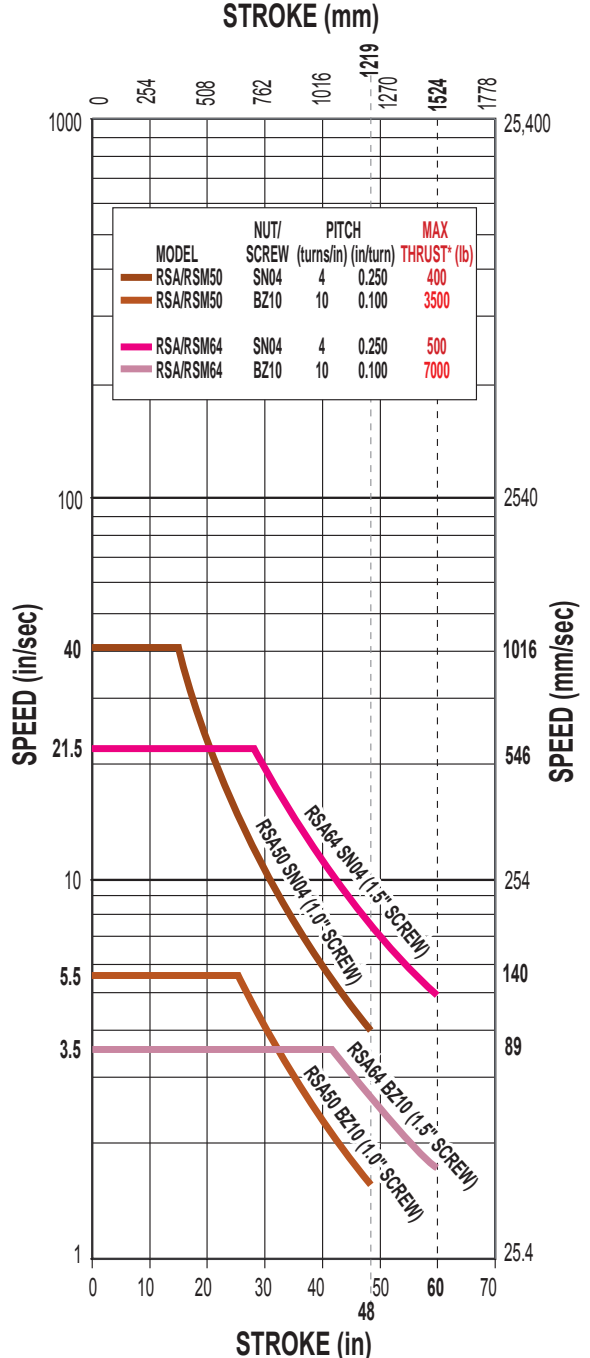
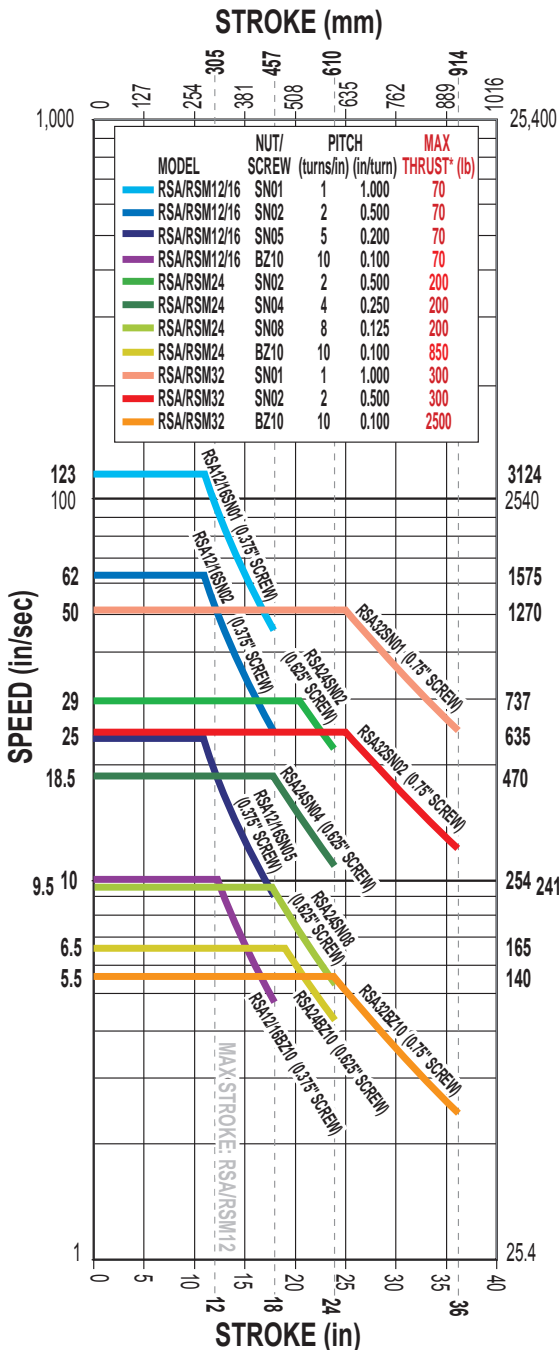

* Maximum thrust is the maximum continuous dynamic thrust subject to Thrust x Velocity limitation.

Dotted lines represent maximum stroke for actuator body size.

For Screw PV limits, refer to the individual charts located in the technical section for each actuator body size.

SCREW CODE	DESCRIPTION
SN	Solid Nut
BZ	Bronze Nut

Axi dyne® RSA/RSM Rod Screw

BALL SCREW/NUT COMBINATIONS

BALL SCREW CRITICAL SPEED CAPACITIES

RSA/RSM12, 16, 24, 32: CRITICAL SPEED WITH ENGLISH BALL SCREW

RSA/RSM50, 64: CRITICAL SPEED WITH ENGLISH BALL SCREW

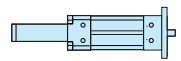
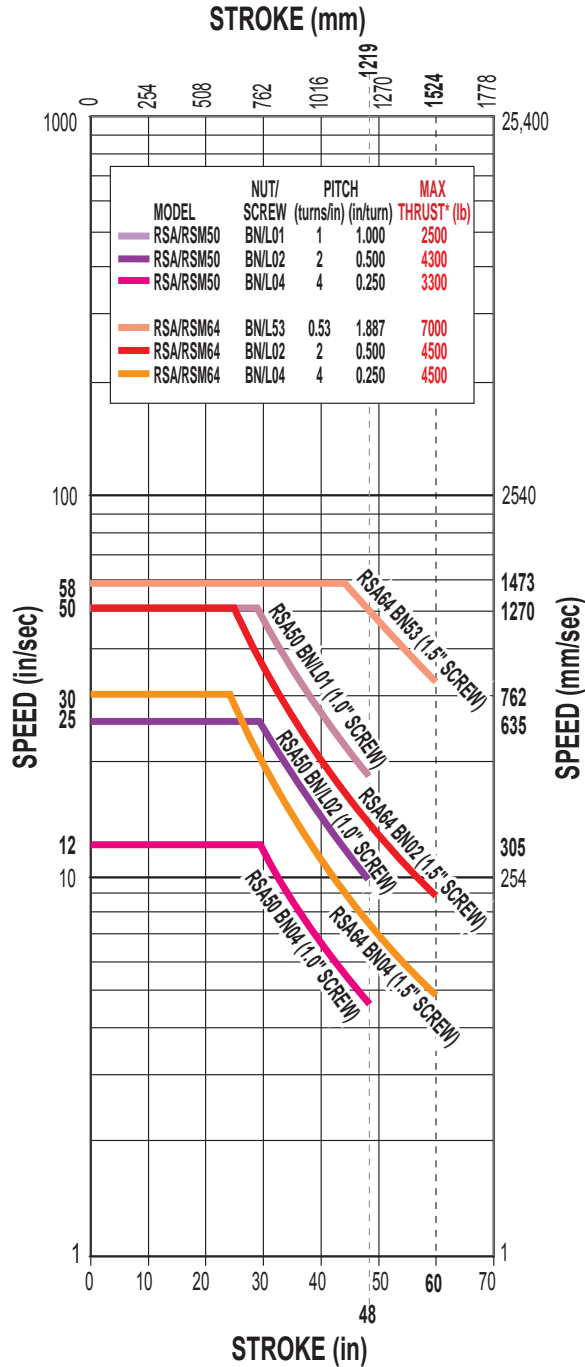
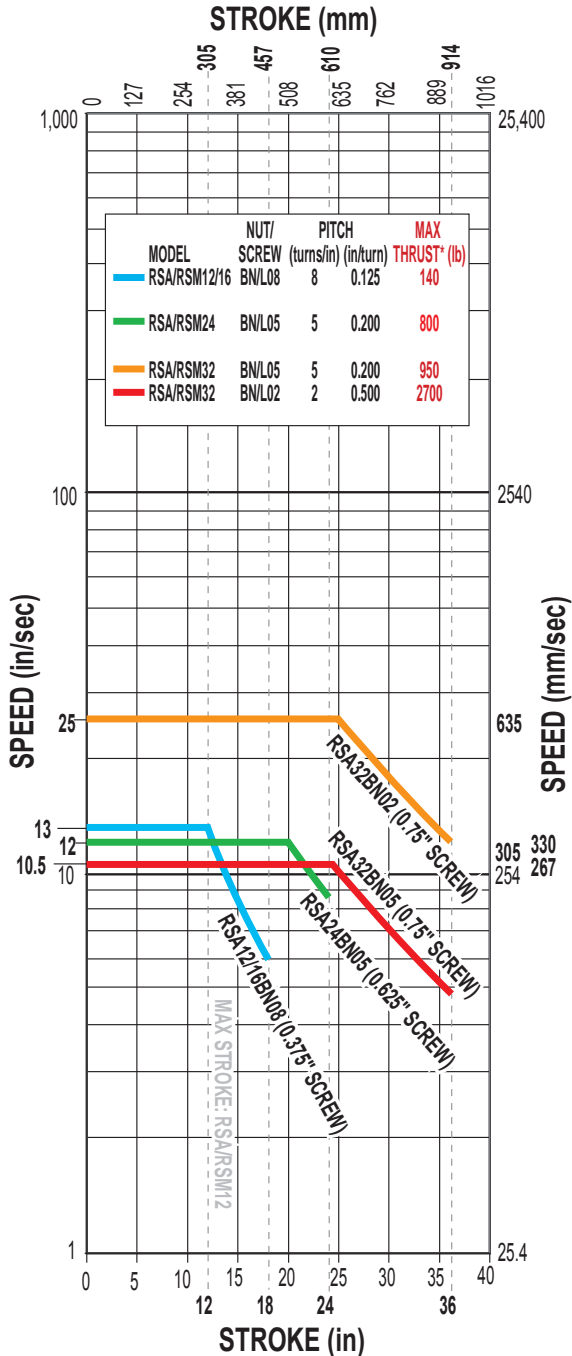

ROD SCREW

- RSA/RSM Series**
- Ball screw critical speed capacities



* Maximum thrust reflects 90% reliability for 1 million linear inches of travel.

Dotted lines represent maximum stroke for screw selections.

SCREW CODE	DESCRIPTION
BN	Ball Nut
BNL	Low-backlash Ball Nut

Axi dyne® RSA/RSM Rod Screw

BALL SCREW/NUT COMBINATIONS

BALL SCREW LIFE CALCULATIONS

RSA/RSM12, 16, 24, 32: LIFE CAPACITIES WITH ENGLISH BALL SCREW

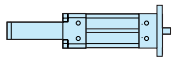
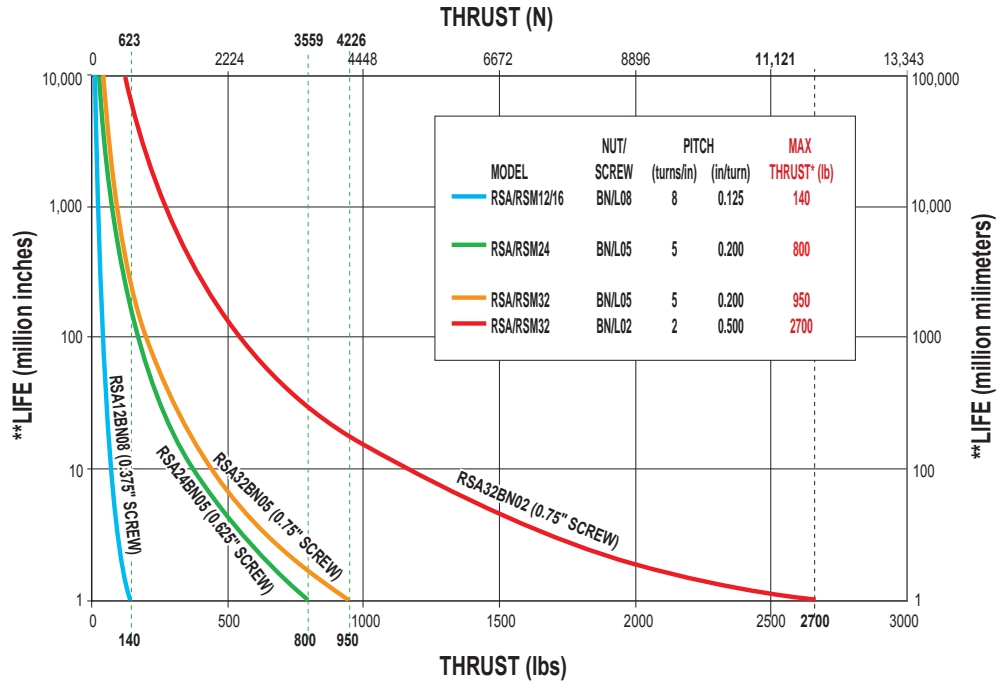

ROD SCREW

RSA/RSM Series

- Ball screw life calculations

RSA50, 64: LIFE CAPACITIES WITH ENGLISH BALL SCREW

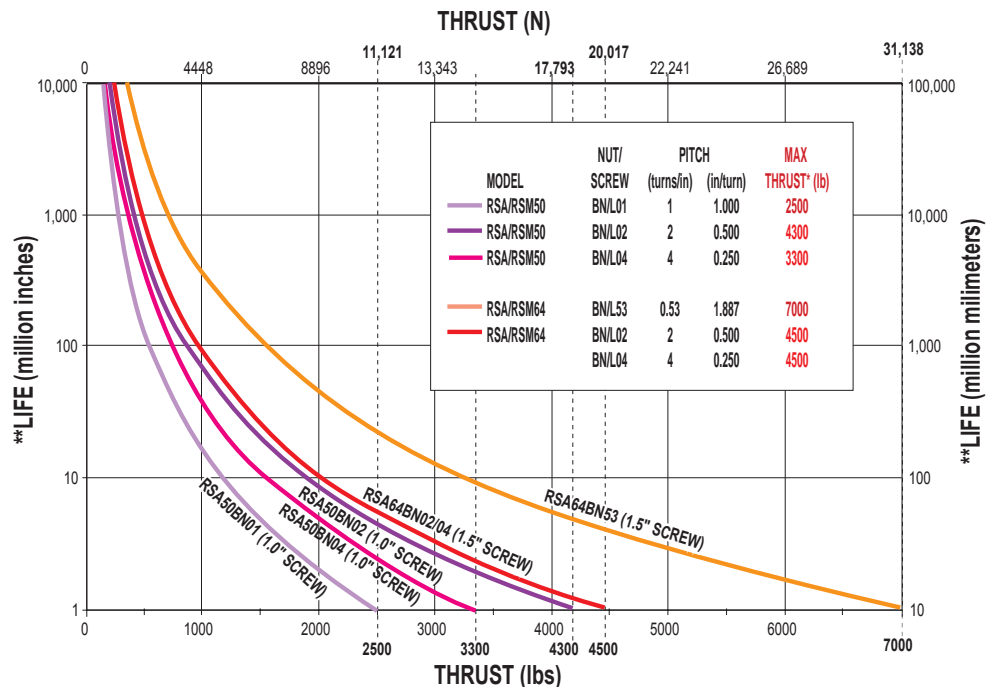

* Maximum thrust reflects 90% reliability for 1 million linear inches of travel.

Dotted lines represent maximum thrust for screw selections.

**Life indicates theoretical maximum life of screw only, under ideal conditions and does not indicate expected life of actuator.



RSA/RSM Rod Screw

OVERALL SERIES SPECIFICATIONS

RSA SPECIFICATIONS RELATED TO ACTUATOR SIZE AND SCREW SELECTION

RSA ACTUATORS WITH ENGLISH LEAD SCREWS												
ACTUATOR SERIES	SCREW DIA. in	SCREW TYPE	TPI turns/in	LEAD ACCURACY in/ft	BACKLASH in	MAXIMUM THRUST* lb	BASE ACTUATOR INERTIA		INERTIA PER/in OF STROKE lb-in ²	BREAKAWAY TORQUE lb-in	MOVING PARTS WEIGHT	
							In Line lb-in ²	Rev. Parallel lb-in ²			Base lb	Per Inch lb
RSA12	0.38	SN01	1	0.010	0.007	70	0.0044	0.0047	0.0015	0.625	0.11	0.04
		SN02	2	0.006	0.007	70	0.0024	0.0026	0.0008	0.563	0.11	0.04
		SN05	5	0.006	0.007	70	0.0018	0.0020	0.0005	0.500	0.11	0.04
		BZ10	10	0.006	0.008	70	0.0017	0.0019	0.0005	0.500	0.11	0.04
		BN08	8	0.003	0.015	140	0.0017	0.0020	0.0005	0.500	0.19	0.04
		BNL08	8	0.003	0.002	140	0.0017	0.0020	0.0005	0.500	0.19	0.04
RSA16	0.38	SN01	1	0.010	0.007	70	0.0064	0.0065	0.0020	1.313	0.19	0.06
		SN02	2	0.006	0.007	70	0.0028	0.0029	0.0009	1.125	0.19	0.06
		SN05	5	0.006	0.007	70	0.0018	0.0019	0.0006	1.063	0.19	0.06
		BZ10	10	0.006	0.008	70	0.0016	0.0017	0.0005	1.063	0.19	0.06
		BN08	8	0.003	0.015	140	0.0017	0.0018	0.0005	1.000	0.27	0.06
		BNL08	8	0.003	0.002	140	0.0017	0.0018	0.0005	1.000	0.27	0.06
RSA24	0.63	SN02	2	0.005	0.007	200	0.0223	0.0227	0.0051	1.813	0.75	0.14
		SN04	4	0.010	0.007	200	0.0187	0.0192	0.0044	1.688	0.75	0.14
		SN08	8	0.010	0.007	200	0.0178	0.0183	0.0042	1.625	0.75	0.14
		BZ10	10	0.006	0.008	850	0.0177	0.0182	0.0042	1.625	0.75	0.14
		BN05	5	0.003	0.015	800	0.0205	0.0209	0.0043	2.188	1.01	0.14
		BNL05	5	0.003	0.002	800	0.0205	0.0209	0.0043	2.188	1.01	0.14
RSA32	0.75	SN01	1	0.005	0.007	300	0.0774	0.0731	0.0125	3.125	0.97	0.15
		SN02	2	0.005	0.007	300	0.0590	0.0547	0.0096	2.688	0.97	0.15
		BZ10	10	0.006	0.008	2500	0.0531	0.0488	0.0087	3.125	0.97	0.15
		BN02	2	0.004	0.015	2700	0.0723	0.0680	0.0096	2.438	1.44	0.15
		BNL02	2	0.004	0.002	2700	0.0723	0.0680	0.0096	2.438	1.44	0.15
		BN05	5	0.003	0.015	950	0.0647	0.0604	0.0088	2.313	1.44	0.15
RSA50	1.00	SN04	4	0.010	0.007	400	0.2060	0.2027	0.0280	4.250	2.62	0.30
		BZ10	10	0.006	0.008	3500	0.3193	0.3160	0.0351	4.125	2.62	0.30
		BN01	1	0.004	0.002	2500	0.3193	0.3160	0.0351	4.125	3.55	0.30
		BNL01	1	0.004	0.002	2500	0.3193	0.3160	0.0351	4.125	3.55	0.30
		BN02	2	0.004	0.015	4300	0.2519	0.2485	0.0294	3.625	3.55	0.30
		BNL02	2	0.004	0.002	4300	0.2519	0.2485	0.0294	3.625	3.55	0.30
		BN04	4	0.004	0.015	3300	0.2350	0.2317	0.0280	4.250	3.55	0.30
		BNL04	4	0.004	0.002	3300	0.2350	0.2317	0.0280	4.250	3.55	0.30
RSA64	1.50	SN04	4	0.010	0.007	500	1.5447	1.5043	0.1399	5.375	5.01	0.45
		BZ10	10	0.006	0.008	7000	1.5380	1.4977	0.1393	5.438	5.01	0.45
		BN53	0.53	0.004	0.015	7000	2.4996	2.4592	0.1797	7.188	7.59	0.45
		BNL53	0.53	0.004	0.002	7000	2.4996	2.4592	0.1797	7.188	7.59	0.45
		BN02	2	0.004	0.015	4500	1.8632	1.8229	0.1420	5.313	7.59	0.45
		BNL02	2	0.004	0.002	4500	1.8632	1.8229	0.1420	5.313	7.59	0.45
		BN04	4	0.004	0.015	4500	1.8272	1.7868	0.1399	5.375	7.59	0.45
		BNL04	4	0.004	0.002	4500	1.8272	1.7868	0.1399	5.375	7.59	0.45

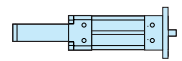

ROD SCREW

RSA/RSM Series

- RSA actuator/screw specifications

SCREW CODE	DESCRIPTION
SN	Solid Nut
BZ	Bronze Nut
BN	Ball Nut
BNL	Low-Backlash Ball Nut



Contact the factory for higher accuracy and lower backlash options.

* For Acme screws, maximum thrust is the maximum continuous dynamic thrust subject to Thrust x Velocity limitation.

For ball screws, maximum thrust reflects 90% reliability for 1 million linear inches of travel.

Axi *dyne*® RSA/RSM Rod Screw

OVERALL SERIES SPECIFICATIONS

RSM SPECIFICATIONS RELATED TO ACTUATOR SIZE AND SCREW SELECTION

RSM METRIC ACTUATORS* WITH ENGLISH LEAD SCREWS

ACTUATOR SERIES	SCREW DIA. in	SCREW TYPE	TPI turns/in	LEAD ACCURACY mm/300	BACKLASH mm	MAXIMUM THRUST** N	BASE ACTUATOR INERTIA		INERTIA PER/in OF STROKE k-m ² x 10 ⁻⁴	BREAKAWAY TORQUE N-m	MOVING PARTS WEIGHT	
							In Line	Rev. Parallel			Base	Per Inch
							k-m ² x 10 ⁻⁴	k-m ² x 10 ⁻⁴			N	N
RSM12	0.38	SN01	1	0.254	0.18	311	1.301	1.377	0.443	0.071	0.489	0.178
		SN02	2	0.152	0.18	311	0.690	0.765	0.220	0.064	0.489	0.178
		SN05	5	0.152	0.18	311	0.518	0.594	0.158	0.056	0.489	0.178
		BZ10	10	0.152	0.20	311	0.494	0.570	0.149	0.056	0.489	0.178
		BN08	8	0.076	0.38	623	0.508	0.584	0.151	0.056	0.845	0.178
		BNL08	8	0.076	0.05	623	0.508	0.584	0.150	0.056	0.845	0.178
RSM16	0.38	SN01	1	0.254	0.18	311	1.866	1.905	0.591	0.148	0.845	0.267
		SN02	2	0.152	0.18	311	0.810	0.849	0.257	0.127	0.845	0.267
		SN05	5	0.152	0.18	311	0.514	0.553	0.164	0.120	0.845	0.267
		BZ10	10	0.152	0.20	311	0.472	0.511	0.151	0.120	0.845	0.267
		BN08	8	0.076	0.38	623	0.489	0.528	0.153	0.113	1.201	0.267
		BNL08	8	0.076	0.05	623	0.489	0.528	0.153	0.113	1.201	0.267
RSM24	0.63	SN02	2	0.127	0.18	890	6.516	6.651	1.486	0.205	3.336	0.623
		SN04	4	0.254	0.18	890	5.474	5.609	1.292	0.191	3.336	0.623
		SN08	8	0.254	0.18	890	5.213	5.349	1.243	0.184	3.336	0.623
		BZ10	10	0.152	0.20	3781	5.182	5.317	1.237	0.184	3.336	0.623
		BN05	5	0.076	0.38	3558	5.991	6.126	1.268	0.247	4.493	0.623
		BNL05	5	0.076	0.02	3558	5.991	6.126	1.268	0.247	4.493	0.623
RSM32	0.75	SN01	1	0.127	0.18	1334	22.651	21.386	3.653	0.353	4.315	0.667
		SN02	2	0.127	0.18	1334	17.261	15.996	2.820	0.304	4.315	0.667
		BZ10	10	0.152	0.20	11120	15.536	14.271	2.553	0.353	4.315	0.667
		BN02	2	0.102	0.38	12010	21.160	19.895	2.820	0.275	6.405	0.667
		BNL02	2	0.102	0.02	12010	21.160	19.895	2.820	0.275	6.405	0.667
		BN05	5	0.076	0.38	4226	18.913	17.655	2.586	0.261	6.405	0.667
RSM50	1.00	SN04	4	0.254	0.18	1779	60.254	59.289	8.180	0.480	11.654	1.334
		BZ10	10	0.152	0.20	15569	59.235	58.270	8.063	0.410	11.654	1.334
		BN01	1	0.102	0.38	11120	93.402	92.422	10.264	0.466	15.791	1.334
		BNL01	1	0.102	0.02	11120	93.402	92.422	10.264	0.466	15.791	1.334
		BN02	2	0.102	0.38	19130	73.675	72.695	8.597	0.410	15.791	1.334
		BNL02	2	0.102	0.02	19130	73.675	72.695	8.597	0.410	15.791	1.334
		BN04	4	0.102	0.38	14680	68.729	67.764	8.180	0.480	15.791	1.334
		BNL04	4	0.102	0.02	14680	68.729	67.764	8.180	0.480	15.791	1.334
RSM64	1.50	SN04	4	0.254	0.18	2224	451.825	440.017	40.913	0.607	22.286	2.002
		BZ10	10	0.152	0.20	31138	449.876	438.068	40.738	0.614	22.286	2.002
		BN53	0.53	0.102	0.38	31138	731.133	719.325	52.574	0.812	33.762	2.002
		BNL53	0.53	0.102	0.02	31138	731.133	719.325	52.574	0.812	33.762	2.002
		BN02	2	0.102	0.38	20017	544.995	533.188	41.538	0.600	33.762	2.002
		BNL02	2	0.102	0.02	20017	544.995	533.188	41.538	0.600	33.762	2.002
		BN04	4	0.102	0.38	20017	534.451	522.644	40.913	0.607	33.762	2.002
		BNL04	4	0.102	0.02	20017	534.451	522.644	40.913	0.607	33.762	2.002

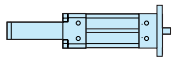

ROD SCREW

RSA/RSM Series

- RSM actuator/screw specifications

SCREW CODE	DESCRIPTION
SN	Solid Nut
BZ	Bronze Nut
BN	Ball Nut
BNL	Low-Backlash Ball Nut



Contact the factory for higher accuracy and lower backlash options.

* RSM metric actuators use the same leadscrew as the RSA English series. Mounting threaded and dowel pin holes on RSM series are metric.

**For Acme screws, maximum thrust is the maximum continuous dynamic thrust subject to Thrust x Velocity limitation.

For ball screws, maximum thrust reflects 90% reliability for 1 million linear inches of travel.

Axi dyne® RSA/RSM Rod Screw

OVERALL SERIES SPECIFICATIONS

GENERAL ACTUATOR SPECIFICATIONS

SPECIFICATIONS	RSA ENGLISH ACTUATORS						
	RSA12		RSA16	RSA24	RSA32	RSA50	RSA64
Weights	17 frame	23 frame					
In-Line base weight (lb)	1.73	1.73	3.73	3.98	6.11	14.21	23.01
Reverse parallel base weight (lb)	2.28	2.42	4.00	5.68	9.76	20.10	28.51
Weight per in (mm) of stroke (lb)	0.013	0.128	0.30	0.33	0.46	0.86	1.38
Maximum Stroke (in)	12		18	24	36	48	60
Temperature Operating Range* (°F)	40 - 130		40 - 130	40 - 130	40 - 130	40 - 130	40 - 130
IP Rating**	66		66	66	66	66	66

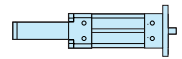

ROD SCREW

- RSA/RSM Series**
- General specifications

SPECIFICATIONS	RSM METRIC ACTUATORS						
	RSM12		RSM16	RSM24	RSM32	RSM50	RSM64
Weights	17 frame	23 frame					
In-Line base weight (kg)	0.78	0.78	1.69	1.80	2.77	6.44	10.43
Reverse parallel base weight (kg)	1.03	1.10	1.81	2.57	4.42	9.11	12.93
Weight per in (mm) of stroke (kg)	0.0002	0.0002	0.00536	0.00589	0.00821	0.01536	0.02464
Maximum Stroke (mm)	304		457	609	914	1219	1524
Temperature Operating Range* (°C)	4 - 54		4 - 54	4 - 54	4 - 54	4 - 54	4 - 54
IP Rating**	66		66	66	66	66	66



* **Heat generated by the motor and drive should be taken into consideration as well as linear velocity and work cycle time. For applications that require operation outside of the recommended temperature range, contact the factory.**

** **Protected against ingress of solid particles greater than .039 in (1mm) and splashing water.**

LARGE FRAME MOTORS AND SMALLER SIZE ACTUATORS: Cantilevered motors need to be supported, if subjected to continuous rapid reversing duty and/or under dynamic conditions.

SIDE LOADING CONSIDERATIONS: Rod screw actuators are designed to push guided and supported loads and are not meant for applications that require substantial side loading. Please contact the factory for details regarding side loading capabilities.

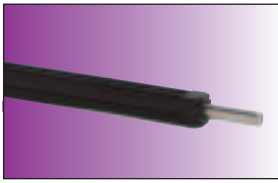

Axi
dyne[®]

RSA/RSM12 Series ACME SCREW SPECIFICATIONS

RSA12 ACME SCREW CRITICAL SPEED AND PV LIMITS

CRITICAL SPEED WITH 0.375" 1TPI ENGLISH ACME SCREW

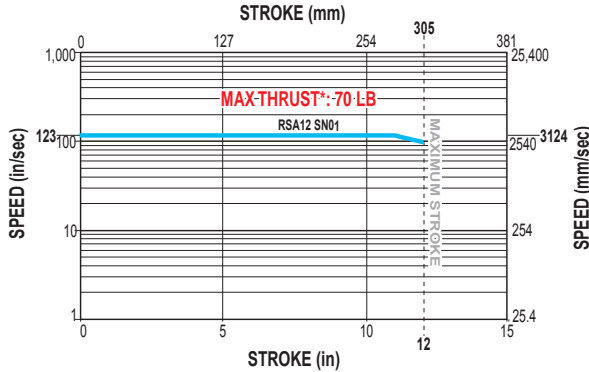

PV LIMITS: 0.375" 1TPI ENGLISH ACME SCREW

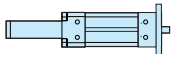
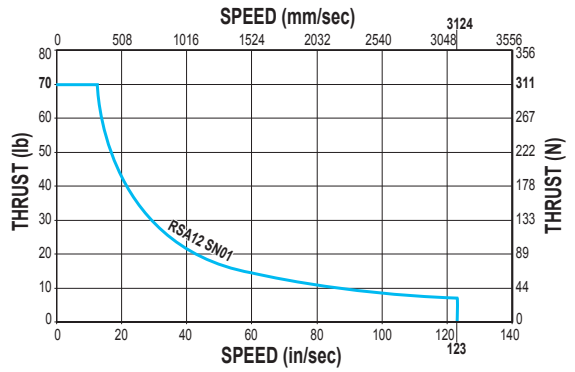

ROD SCREW

RSA/RSM12 Series

- Acme screw critical speed

CRITICAL SPEED WITH 0.375" 2TPI ENGLISH ACME SCREW

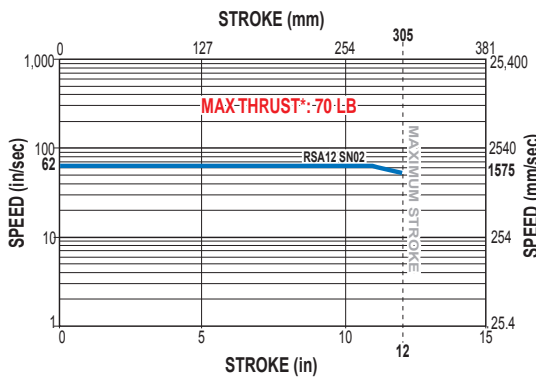

PV LIMITS: 0.375" 2TPI ENGLISH ACME SCREW

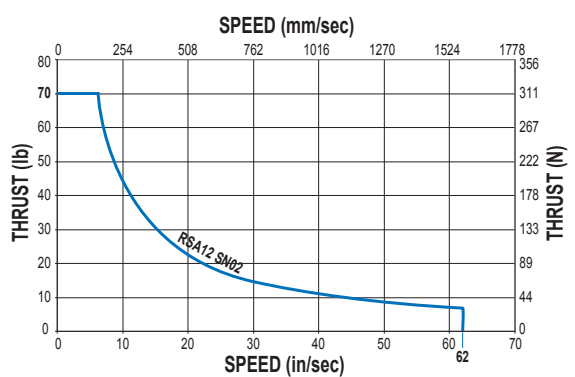

CRITICAL SPEED WITH 0.375" 5TPI ENGLISH ACME SCREW

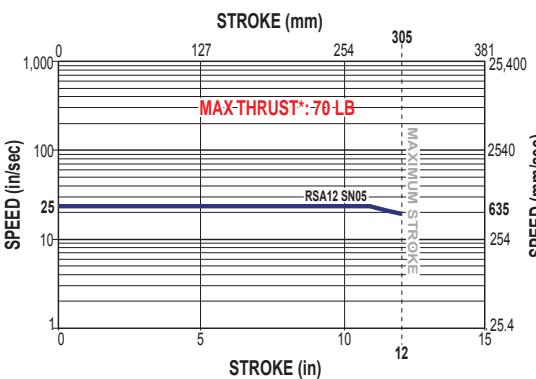

PV LIMITS: 0.375" 5TPI ENGLISH ACME SCREW

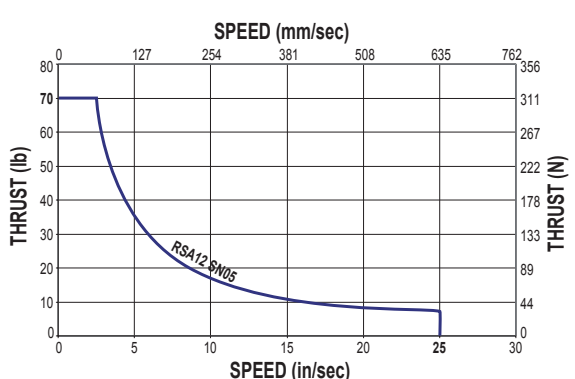

SN = Solid Nut



* Maximum thrust is the maximum continuous dynamic thrust subject to Thrust x Velocity limitation.

PV LIMITS: Any material which carries a sliding load is limited by heat buildup. The factors that affect heat generation rate in an application are the pressure on the nut in pounds per square inch and the surface velocity in feet per minute. The product of these factors provides a measure of the severity of an application.

$$P = \frac{\text{Thrust}}{\text{Max. Thrust Rating}} \times V = \frac{\text{Speed}}{\text{Max. Speed Rating}} \leq 0.1$$

Axi-dyne® RSA/RSM12 Series

ACME SCREW SPECIFICATIONS

RSA12 ACME SCREW CRITICAL SPEED AND PV LIMITS (continued)

CRITICAL SPEED WITH 0.375" 10TPI ENGLISH ACME SCREW

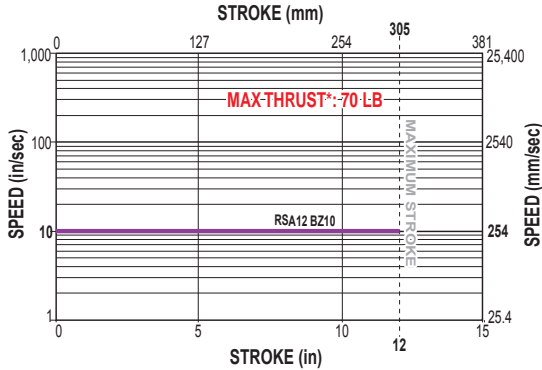

PV LIMITS: 0.375" 10TPI ENGLISH ACME SCREW

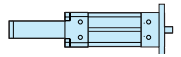
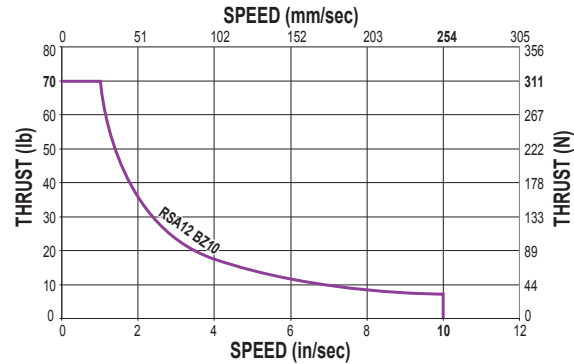

ROD SCREW

RSA/RSM12 Series

- Acme screw critical speed and PV limits
- Ball screw critical speed and life calculations

BZ = Bronze Nut



* *Maximum thrust is the maximum continuous dynamic thrust subject to Thrust x Velocity limitation.*

PV LIMITS: Any material which carries a sliding load is limited by heat buildup. The factors that affect heat generation rate in an application are the pressure on the nut in pounds per square inch and the surface velocity in feet per minute. The product of these factors provides a measure of the severity of an application.

$$P = \frac{\text{Thrust}}{\text{Max. Thrust Rating}} \times V = \frac{\text{Speed}}{\text{Max. Speed Rating}} \leq 0.1$$

RSA12 BALL SCREW CRITICAL SPEED AND LIFE CALCULATIONS

CRITICAL SPEED WITH 0.375" 8TPI ENGLISH BALL SCREW

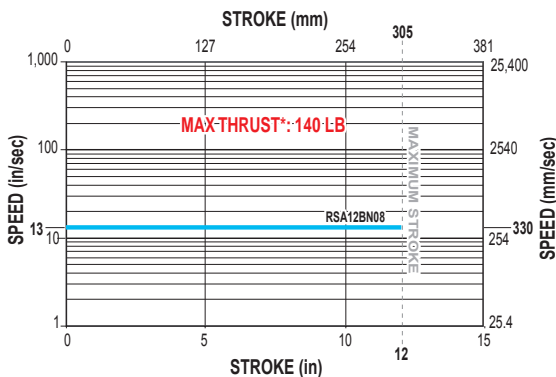

LIFE CALCULATION: 0.375" 8TPI ENGLISH BALL SCREW

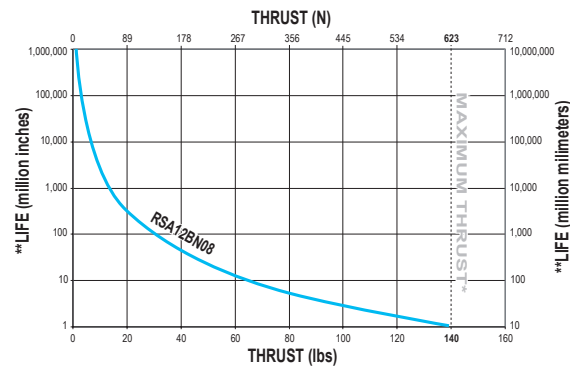

BN = Ball Nut



* *Maximum thrust reflects 90% reliability for 1 million linear inches of travel.*

** *Life indicates theoretical maximum life of screw only, under ideal conditions and does not indicate expected life of actuator.*

Axi-dyne® RSA/RSM12 Series

DIMENSIONS

RSA/RSM12 IN-LINE (LMI) BASE MODEL AND SWITCH MOUNTING

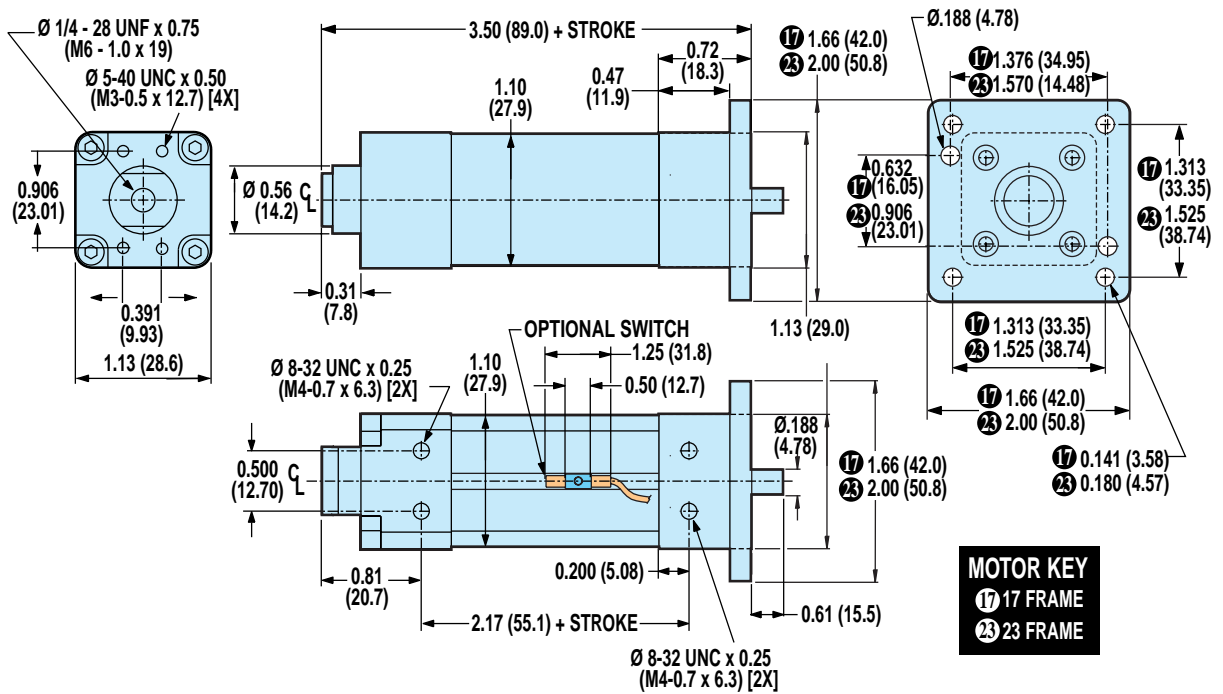

Unless otherwise noted, all dimensions shown are in inches (Dimensions in parenthesis are in millimeters)

Axi-dyne® RSA/RSM12 Series

DIMENSIONS

RSA/RSM12 REVERSE PARALLEL (RP) BASE MODEL OPTIONS AND SWITCH MOUNTING

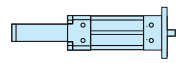
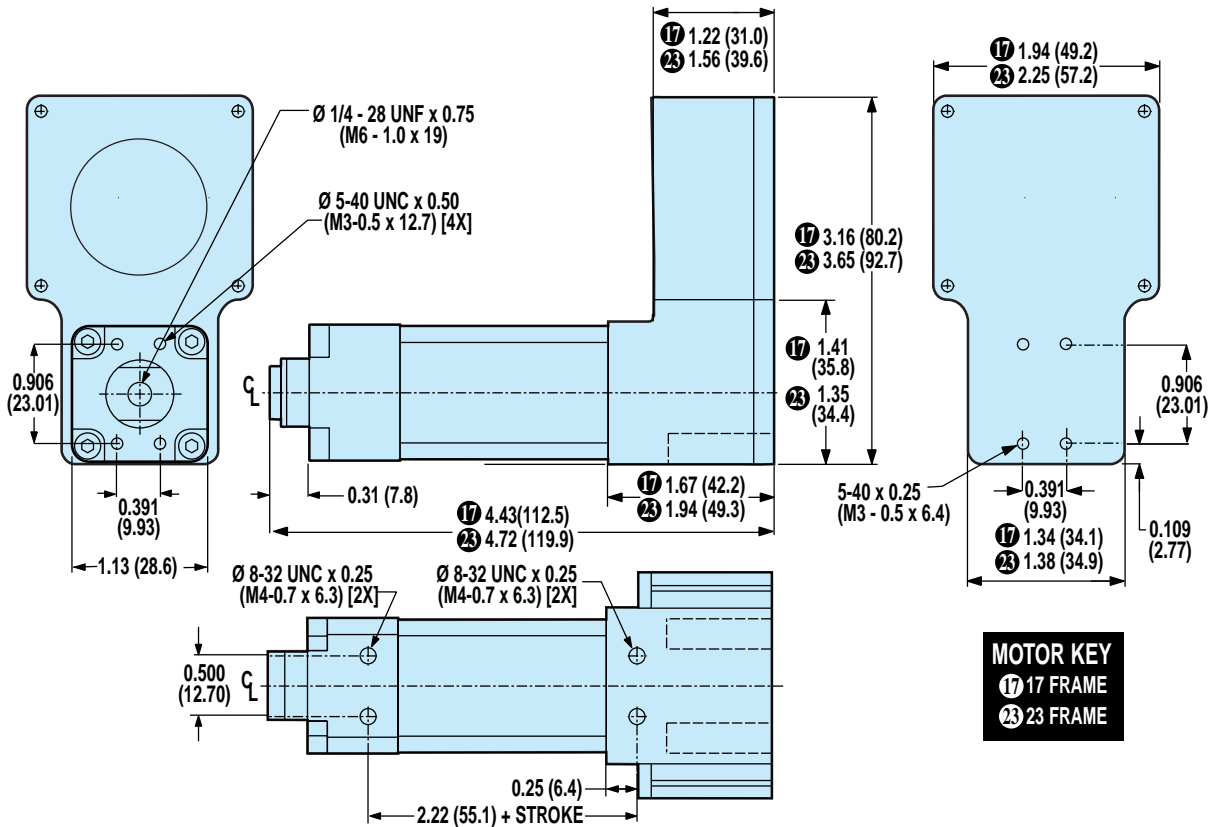

ROD SCREW

RSA/RSM12 Series

- Reverse parallel base model options and switch mounting

OPTIONAL TRUNNION MOUNT: TRN

⚠ TRUNNION MOUNTS ARE NOT FIELD RETROFITTABLE AND MUST BE CONFIGURED AS PART OF THE BASE ACTUATOR. CONTACT THE FACTORY FOR ADDITIONAL INFORMATION.

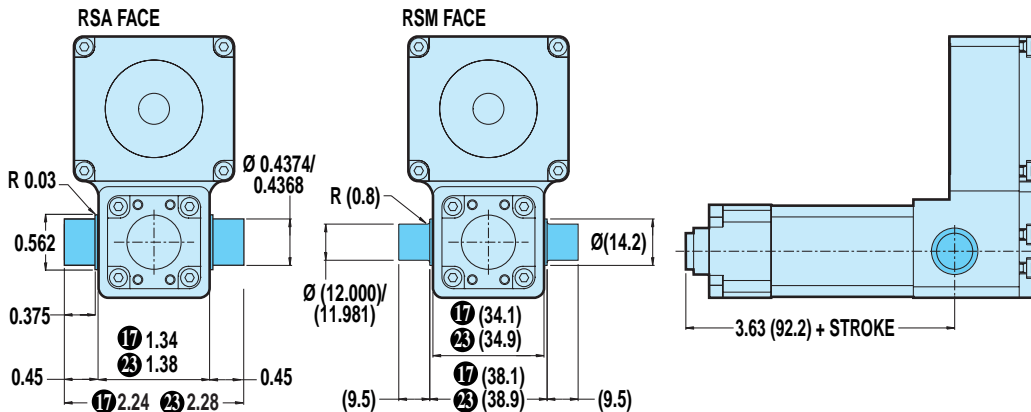

OPTIONAL SWITCH MOUNTING ⚠⚡

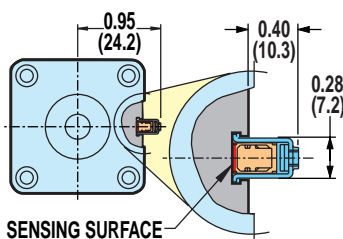

⚠ CAUTION: DO NOT OVERTIGHTEN SWITCH HARDWARE WHEN INSTALLING

Ⓜ NOTE: The scored face of the switch indicates the sensing surface and must face toward the magnet

Axi dyne® RSA/RSM12 Series

DIMENSIONS

RSA/RSM12 RETROFITTABLE ROD END OPTIONS

FOR IN-LINE (LMI) OR REVERSE PARALLEL (RP) MODELS

OPTIONAL Spherical Rod Eye End: SRE

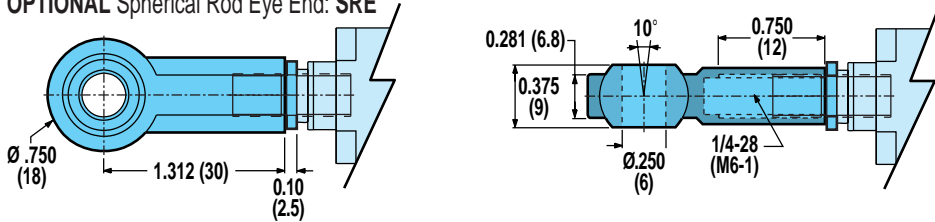

OPTIONAL Alignment Coupler Rod End: ALC

INTERNALLY THREADED END SPECIFIED

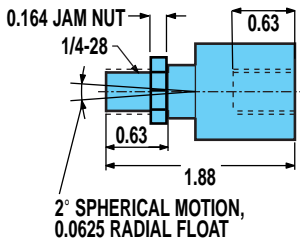

EXTERNALLY THREADED END SPECIFIED

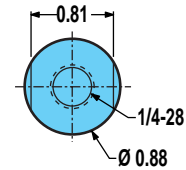
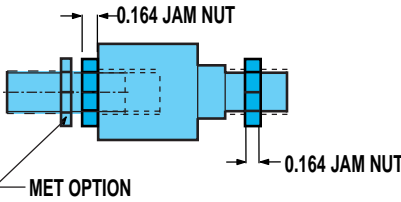

! THE ALIGNMENT COUPLER COMES WITH AN INTERNAL THREAD. IF AN EXTERNAL THREAD IS PREFERRED, THE ADDITION OF THE "MET" OPTION IS REQUIRED.

NOT AVAILABLE ON THE RSM12 METRIC MODEL.

OPTIONAL External Threaded Rod End: MET

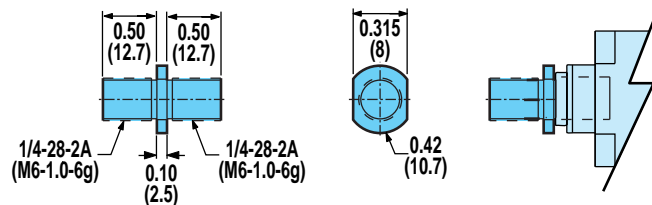

OPTIONAL Clevis Rod End: CLV

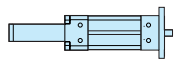
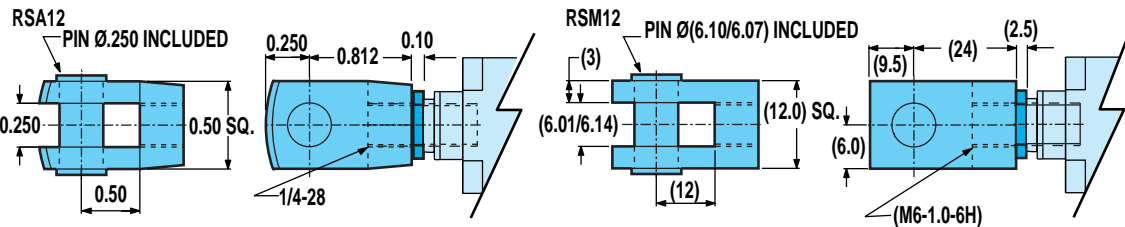

ROD SCREW

RSA/RSM12 Series

- Retrofittable rod end options

Axi-dyne® RSA/RSM12 Series

DIMENSIONS

RSA/RSM12 RETROFITTABLE MOUNTING OPTIONS

REVERSE PARALLEL (RP) MODELS ONLY

OPTIONAL Clevis Mount: PCD

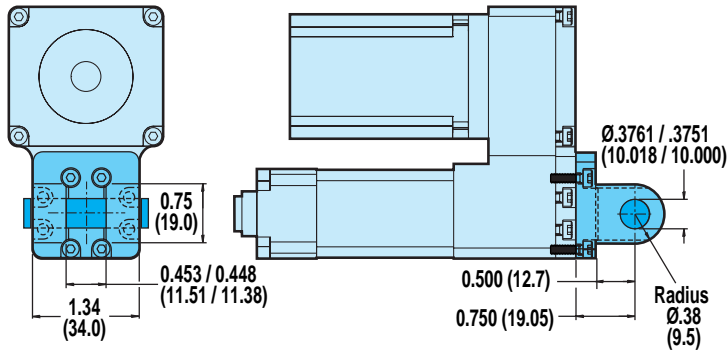

OPTIONAL Eye Mount: PCS

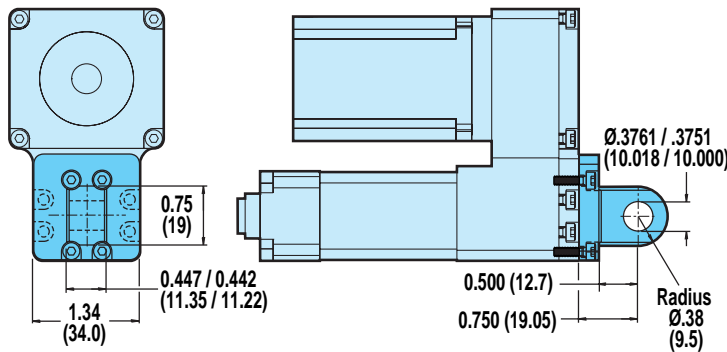

OPTIONAL Foot Mount: FM2

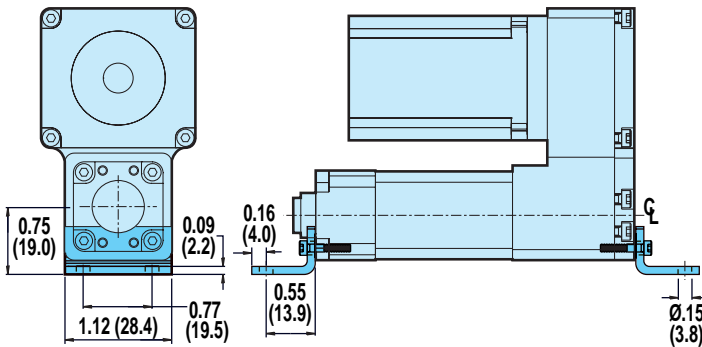

OPTIONAL Back Flange: BFG

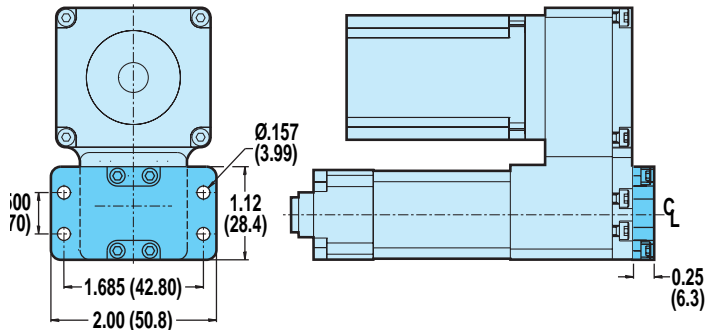

FOR IN-LINE (LMI) OR REVERSE PARALLEL (RP) MODELS

OPTIONAL Mounting Plate: MP2

MOTOR KEY
17 17 FRAME
23 23 FRAME

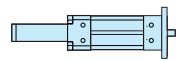
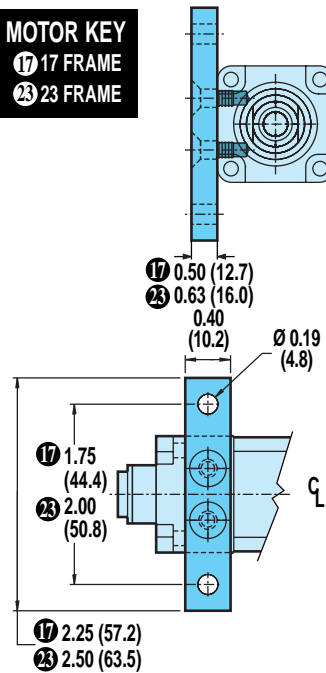

ROD SCREW

RSA/RSM12 Series

- Retrofittable mounting options

OPTIONAL Front Flange Mount: FFG

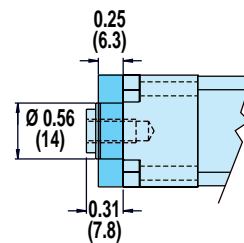
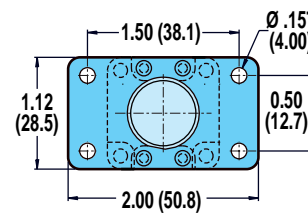

Axi dyne® RSA/RSM12 Series

DIMENSIONS

RSA/RSM12: IN-LINE MOUNTING FOR 17-FRAME MOTORS

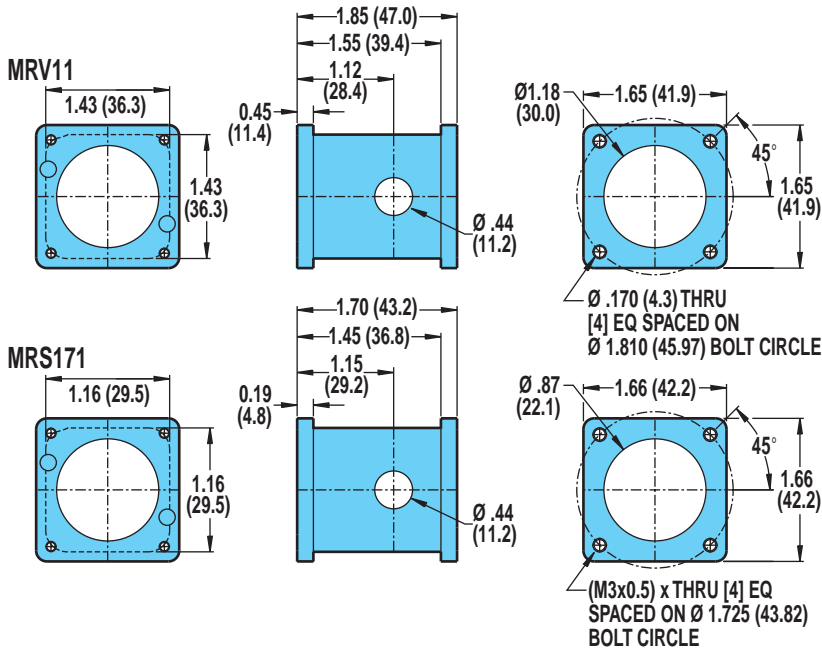

Gearheads are not available for the RSA/RSM12.

For a complete part listing of screw-drive motor and gear-head mounting kits referencing actuator/motor/coupler compatibilities, refer to document 3600-4631 available on the Literature/Part Sheet/Axidyne section of our web site at: www.tolomatic.com.

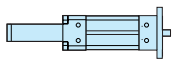

ROD SCREW

RSA/RSM12 Series

- In-line motor mounting

RSA/RSM12: IN-LINE MOUNTING FOR 23-FRAME MOTORS

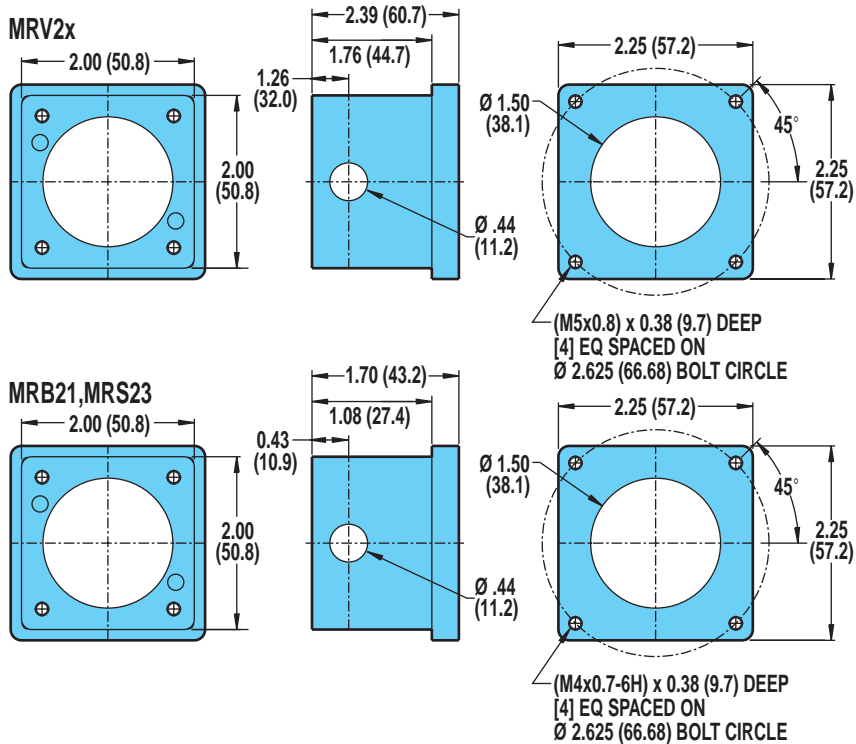

Gearheads are not available for the RSA/RSM12.

For a complete part listing of screw-drive motor and gear-head mounting kits referencing actuator/motor/coupler compatibilities, refer to document 3600-4631 available on the Literature/Part Sheet/Axidyne section of our web site at: www.tolomatic.com.

Axi dyne® RSA/RSM12 Series

DIMENSIONS

RSA/RSM12: REVERSE PARALLEL MOTOR MOUNTING

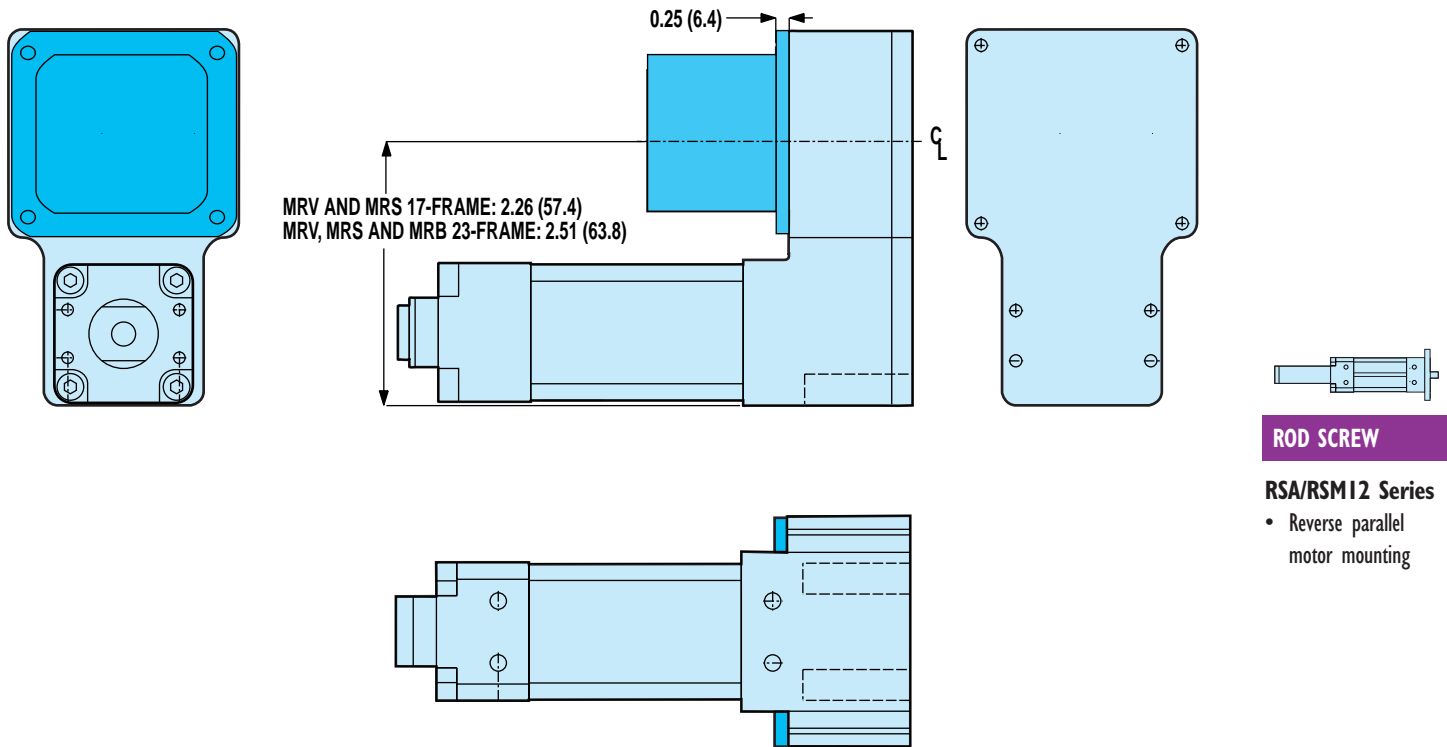

SPECIFICATIONS

	MOTOR	REDUCTION INERTIA AT MOTOR SHAFT	
		1:1	
		lb-in ²	kg-m ² x 10 ⁻⁴ x 10 ⁻⁶
BRUSHLESS	MRV11	0.001	0.289
	MRV21, 22, 23, 24	0.037	10.676
STEPPER	MRS171	0.001	0.296
	MRS231, 232	0.007	1.913
BRUSHED	MRB21	0.007	1.920

REDUCTION EFFICIENCY: 0.95

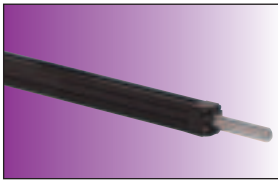

Axi
dyne[®]

RSA/RSM16 Series ACME SCREW SPECIFICATIONS

RSA16 ACME SCREW CRITICAL SPEED AND PV LIMITS

CRITICAL SPEED WITH 0.375" 1TPI ENGLISH ACME SCREW

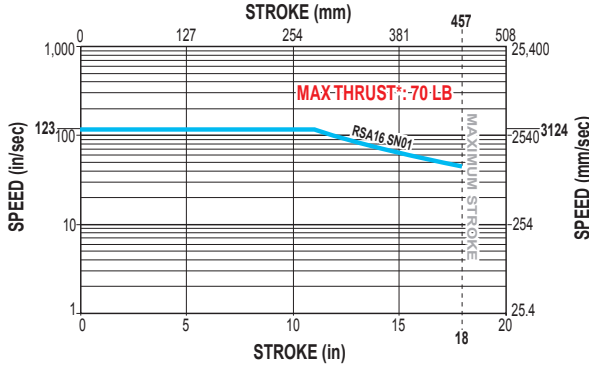

PV LIMITS: 0.375" 1TPI ENGLISH ACME SCREW

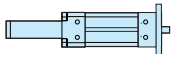
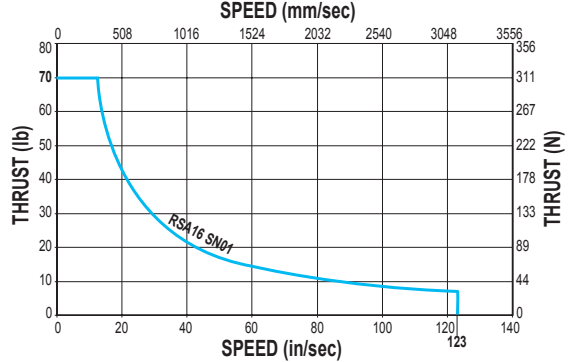

ROD SCREW

RSA/RSM16 Series

- Acme screw critical speed and PV limits

CRITICAL SPEED WITH 0.375" 2TPI ENGLISH ACME SCREW

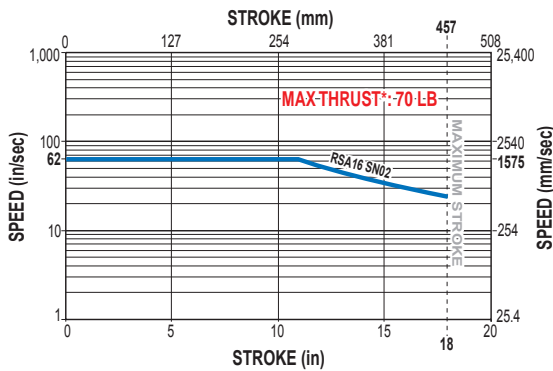

PV LIMITS: 0.375" 2TPI ENGLISH ACME SCREW

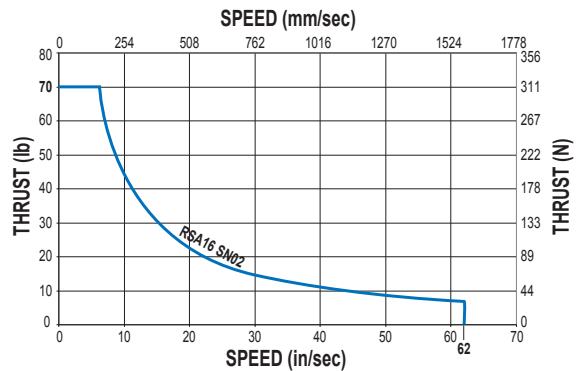

CRITICAL SPEED WITH 0.375" 5TPI ENGLISH ACME SCREW

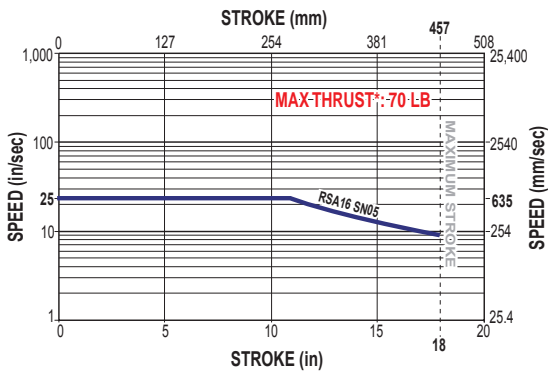

PV LIMITS: 0.375" 5TPI ENGLISH ACME SCREW

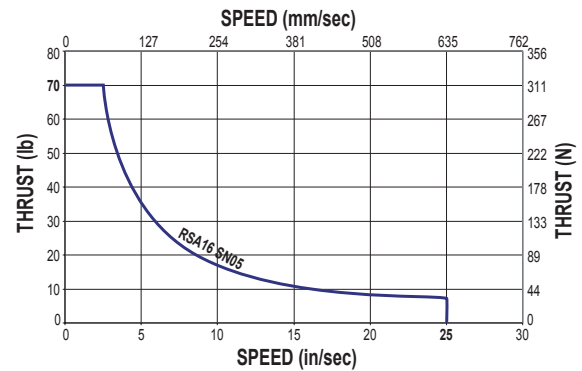

SN = Solid Nut



* Maximum thrust is the maximum continuous dynamic thrust subject to Thrust x Velocity limitation.

PV LIMITS: Any material which carries a sliding load is limited by heat buildup. The factors that affect heat generation rate in an application are the pressure on the nut in pounds per square inch and the surface velocity in feet per minute. The product of these factors provides a measure of the severity of an application.

$$P = \frac{\text{Thrust}}{\text{Max. Thrust Rating}} \times V = \frac{\text{Speed}}{\text{Max. Speed Rating}} \leq 0.1$$

Axi-dyne® RSA/RSMI6 Series

ACME AND BALL SCREW SPECIFICATIONS

RSA16 ACME SCREW CRITICAL SPEED AND PV LIMITS (continued)

CRITICAL SPEED WITH 0.375" 10TPI ENGLISH ACME SCREW

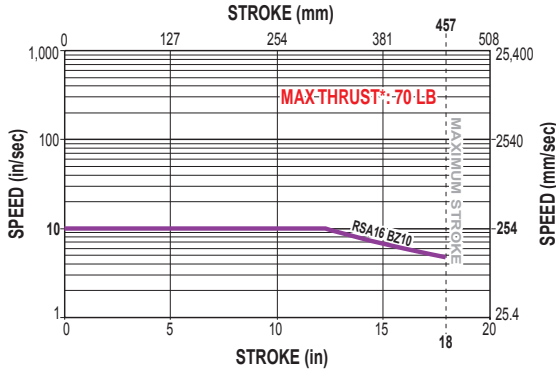

PV LIMITS: 0.375" 10TPI ENGLISH ACME SCREW

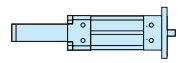
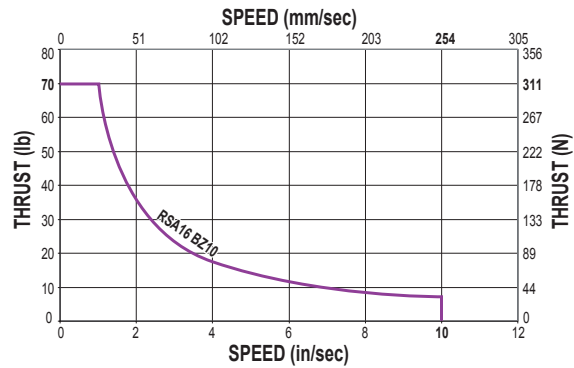

ROD SCREW

BZ = Bronze Nut

RSA/RSMI6 Series

- Acme screw critical speed and PV limits
- Ball screw critical speed and life calculations



* *Maximum thrust is the maximum continuous dynamic thrust subject to Thrust x Velocity limitation.*

PV LIMITS: Any material which carries a sliding load is limited by heat buildup. The factors that affect heat generation rate in an application are the pressure on the nut in pounds per square inch and the surface velocity in feet per minute. The product of these factors provides a measure of the severity of an application.

$$P = \frac{\text{Thrust}}{\text{Max. Thrust Rating}} \times V = \frac{\text{Speed}}{\text{Max. Speed Rating}} \leq 0.1$$

RSA16 BALL SCREW CRITICAL SPEED AND LIFE CALCULATIONS

CRITICAL SPEED WITH 0.375" 8TPI ENGLISH BALL SCREW

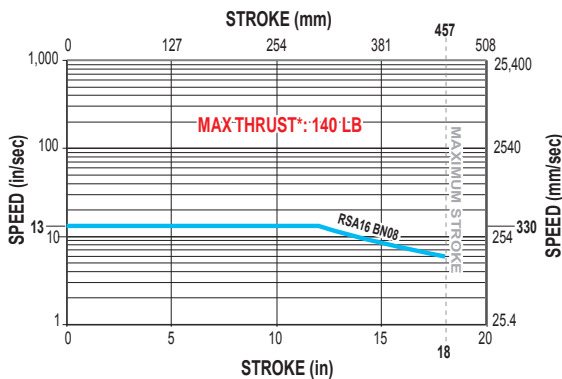

LIFE CALCULATION: 0.375" 8TPI ENGLISH BALL SCREW

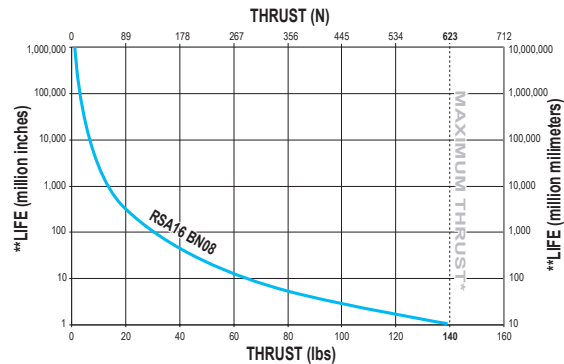

BN = Ball Nut



* *Maximum thrust reflects 90% reliability for 1 million linear inches of travel.*

** *Life indicates theoretical maximum life of screw only, under ideal conditions and does not indicate expected life of actuator.*

Axi-dyne® RSA/RSM16 Series

DIMENSIONS

RSA/RSM16 IN-LINE (LMI) BASE MODEL OPTIONS AND SWITCH MOUNTING

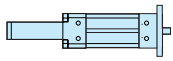
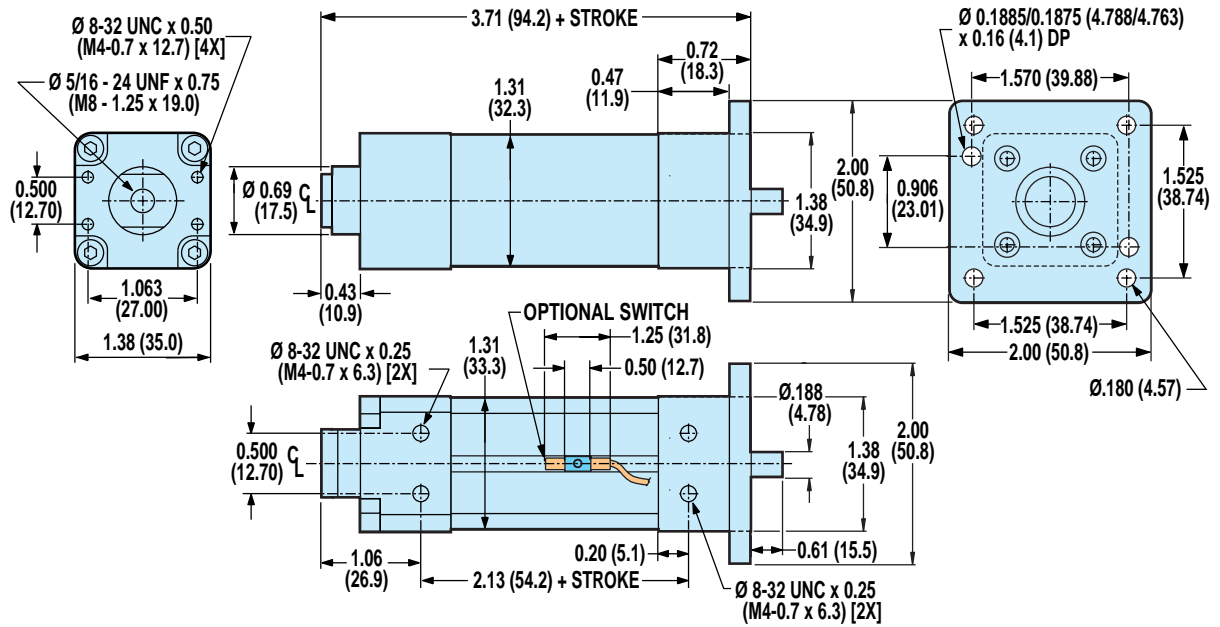

ROD SCREW

RSA/RSM16 Series

- In-line (LMI) base model dimensions

OPTIONAL SWITCH MOUNTING ⓐⓑ

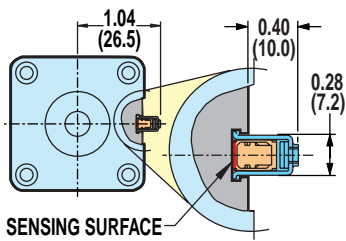

- ⓐ CAUTION: DO NOT OVERTIGHTEN SWITCH HARDWARE WHEN INSTALLING
- ⓑ NOTE: The scored face of the switch indicates the sensing surface and must face toward the magnet

Unless otherwise noted, all dimensions shown are in inches (Dimensions in parenthesis are in millimeters)

Axi-dyne® RSA/RSM16 Series

DIMENSIONS

RSA/RSM16 REVERSE PARALLEL (RP) BASE MODEL OPTIONS AND SWITCH MOUNTING

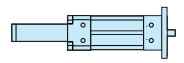
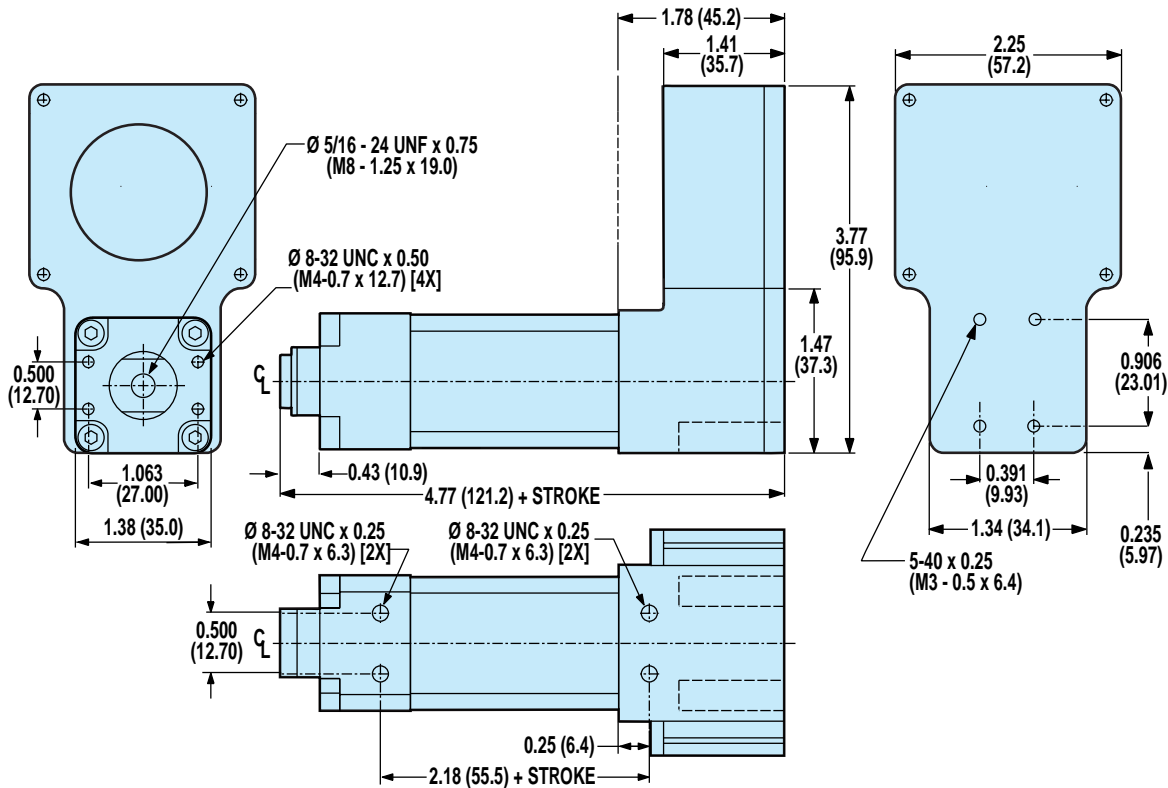

ROD SCREW

RSA/RSM16 Series

- Reverse parallel base model options and switch mounting

OPTIONAL TRUNNION MOUNT: TRN

⚠ TRUNNION MOUNTS ARE NOT FIELD RETROFITTABLE AND MUST BE CONFIGURED AS PART OF THE BASE ACTUATOR. CONTACT THE FACTORY FOR ADDITIONAL INFORMATION.

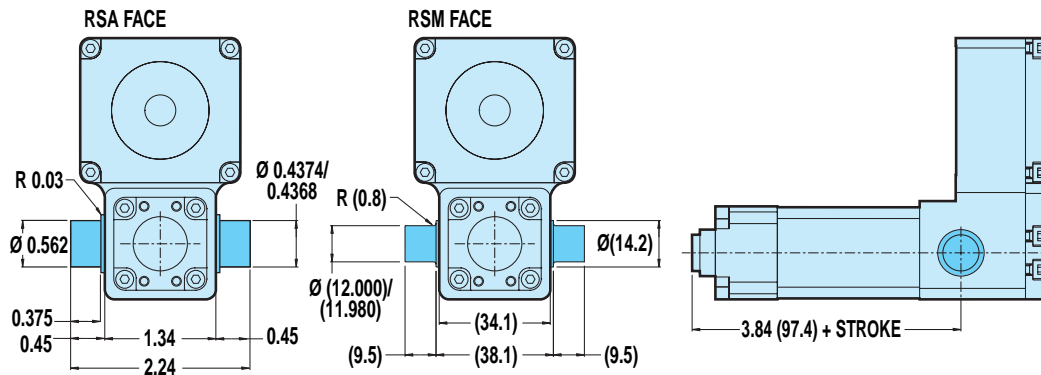

OPTIONAL SWITCH MOUNTING **⚠** **Ⓜ**

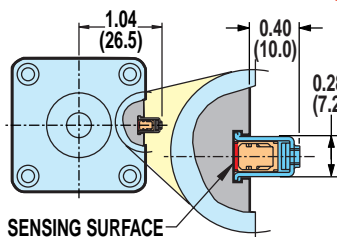

- ⚠ CAUTION: DO NOT OVERTIGHTEN SWITCH HARDWARE WHEN INSTALLING**
- Ⓜ NOTE: The scored face of the switch indicates the sensing surface and must face toward the magnet**

Axi dyne® RSA/RSM16 Series

DIMENSIONS

RSA/RSM16 RETROFITTABLE ROD END OPTIONS

FOR IN-LINE (LMI) OR REVERSE PARALLEL (RP) MODELS

OPTIONAL Spherical Rod Eye End: SRE

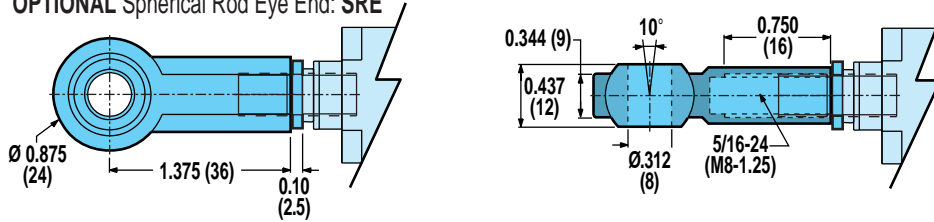

OPTIONAL Alignment Coupler Rod End: ALC

INTERNALLY THREADED END SPECIFIED

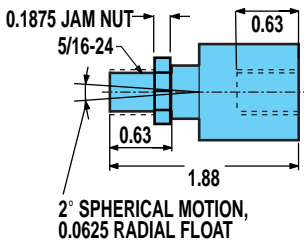

EXTERNALLY THREADED END SPECIFIED

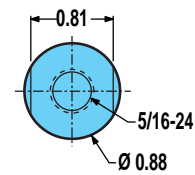
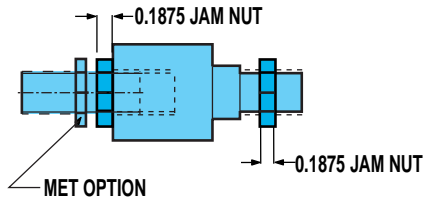

! THE ALIGNMENT COUPLER COMES WITH AN INTERNAL THREAD. IF AN EXTERNAL THREAD IS PREFERRED, THE ADDITION OF THE "MET" OPTION IS REQUIRED.

NOT AVAILABLE ON THE RSM16 METRIC MODEL.

OPTIONAL External Threaded Rod End: MET

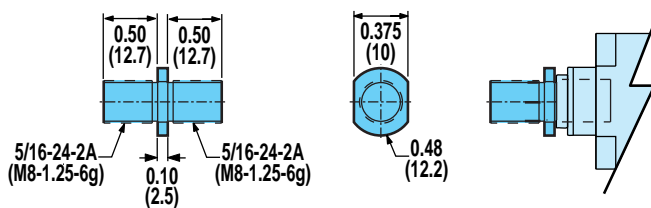

OPTIONAL Clevis Rod End: CLV

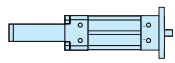
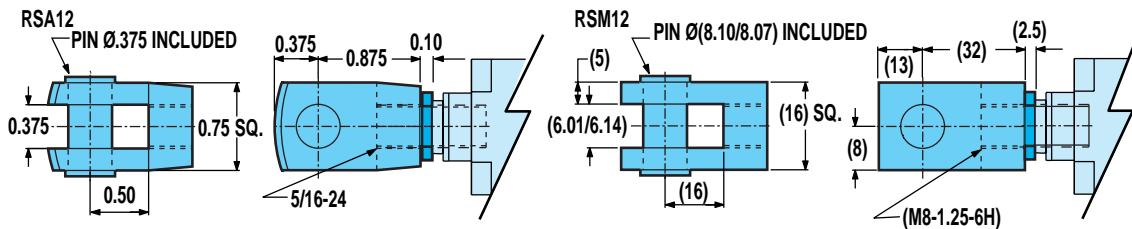

ROD SCREW

RSA/RSM16 Series

- Retrofittable rod end options

Axi dyne® RSA/RSM16 Series

DIMENSIONS

RSA/RSM16 RETROFITTABLE MOUNTING OPTIONS

FOR REVERSE PARALLEL (RP) MODELS ONLY

OPTIONAL Clevis Mount: PCD (for use on RP models only)

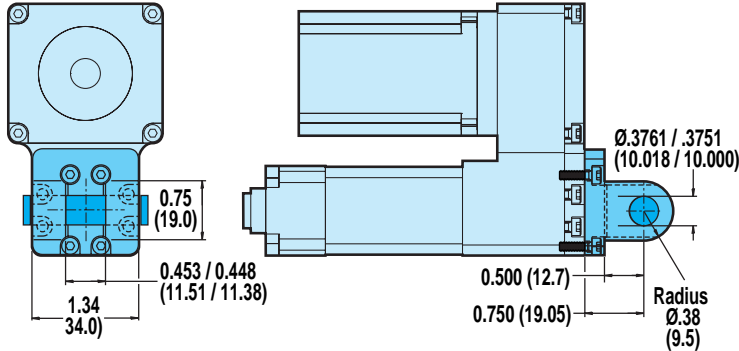

OPTIONAL Eye Mount: PCS

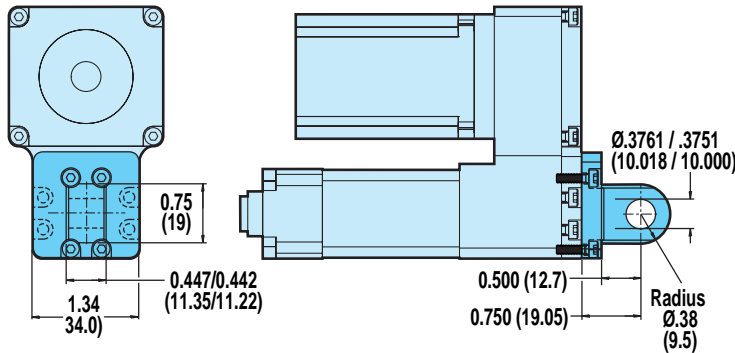

OPTIONAL Foot Mount: FM2

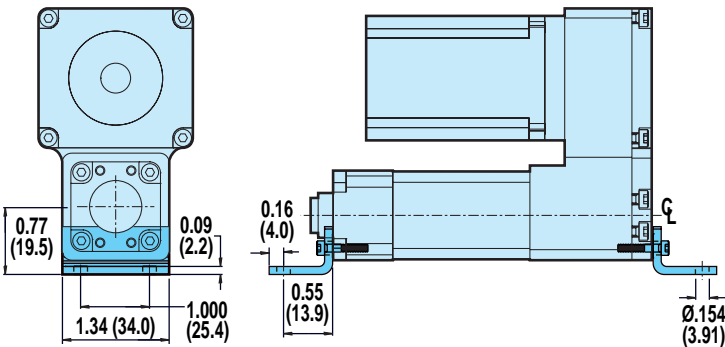

OPTIONAL Back Flange: BFG

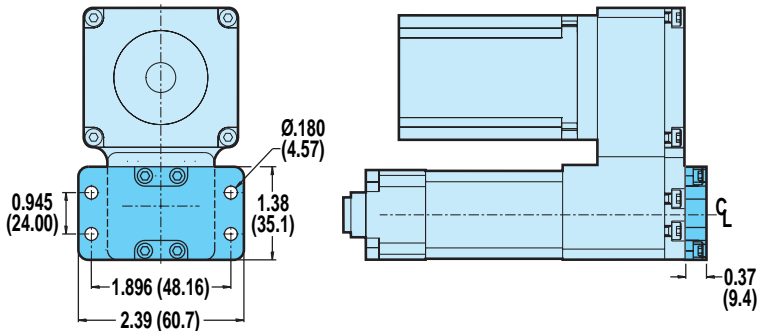

FOR IN-LINE (LMI) OR REVERSE PARALLEL (RP) MODELS

OPTIONAL Mounting Plate: MP2

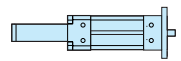
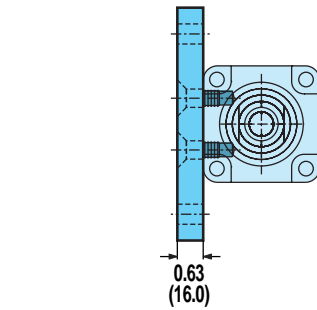

ROD SCREW

RSA/RSM16 Series

- Retrofittable mounting options

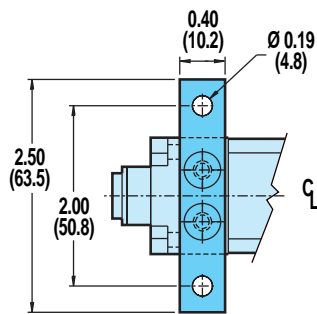

OPTIONAL Front Flange Mount: FFG

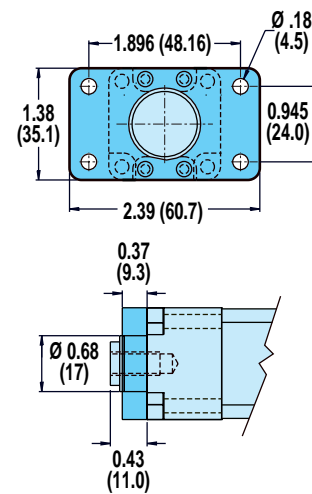

Axi dyne® RSA/RSM16 Series

DIMENSIONS

RSA/RSM16: IN-LINE MOTOR MOUNTING

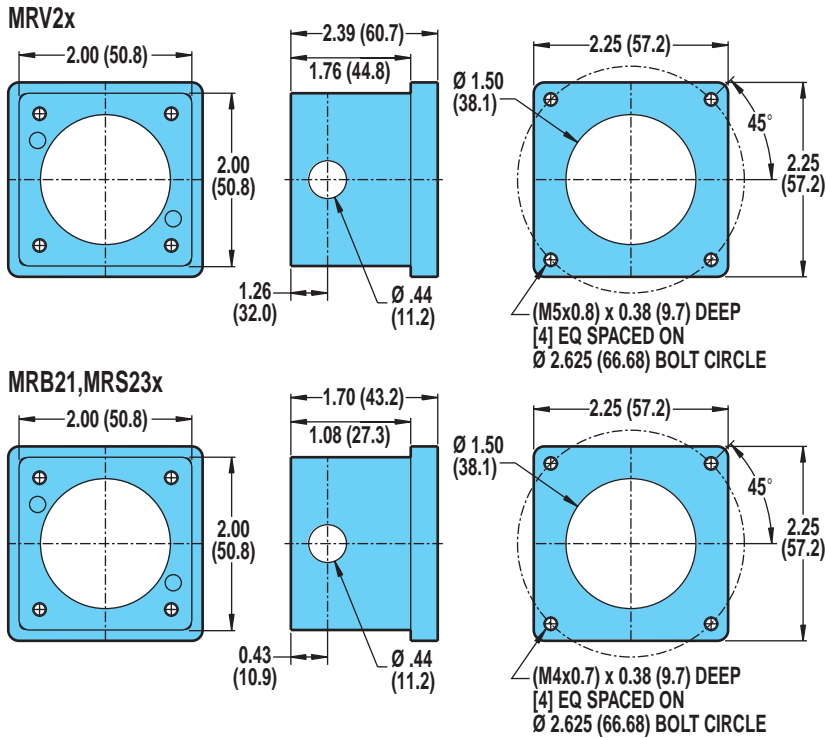

Gearheads are not available for the RSA/RSM16

For a complete part listing of screw-drive motor and gearhead mounting kits referencing actuator/motor/coupler compatibilities, refer to document 3600-4631 available on the Literature/Part Sheet/Axidyne section of our web site at: www.tolomatic.com.

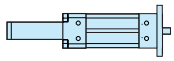

ROD SCREW

RSA/RSM16 Series

- In-line motor mounting
- Reverse parallel motor mounting

RSA/RSM16: REVERSE PARALLEL MOTOR MOUNTING

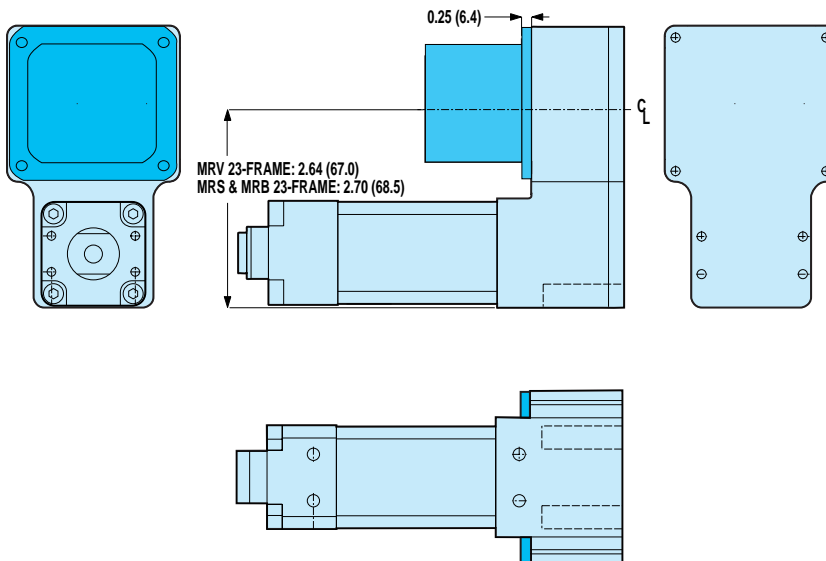

SPECIFICATIONS

MOTOR	REDUCTION INERTIA AT MOTOR SHAFT	
	I:I	
	lb-in ²	kg-m ² x 10 ⁻⁶
BRUSHLESS MRV21, 22, 23, 24	0.037	10.676
STEPPER MRS231, 232	0.007	1.913
BRUSHED MRB21	0.007	1.920

REDUCTION EFFICIENCY: 0.95

Axi-dyne® RSA/RSM24 Series

ACME SCREW SPECIFICATIONS

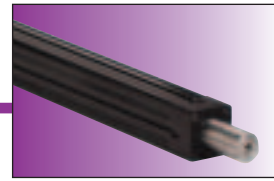

RSA24 ACME SCREW CRITICAL SPEED AND PV LIMITS

CRITICAL SPEED WITH 0.625" 2TPI ENGLISH ACME SCREW

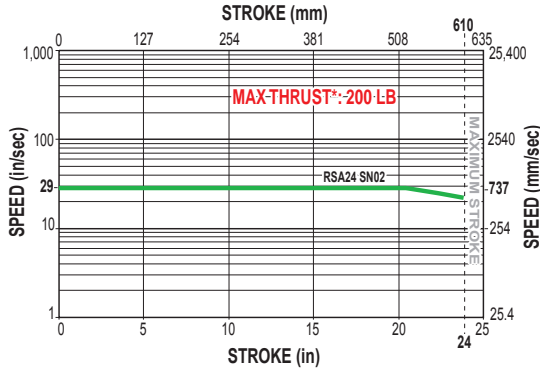

PV LIMITS: 0.625" 2TPI ENGLISH ACME SCREW

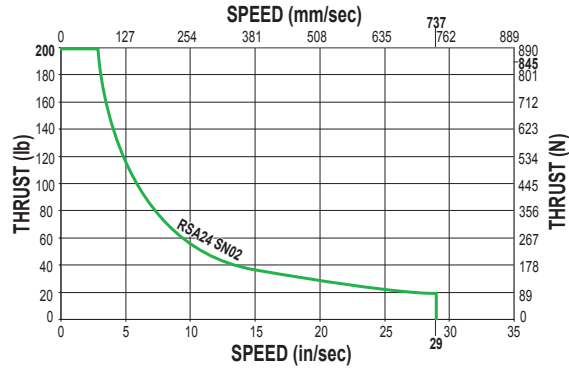

CRITICAL SPEED WITH 0.625" 4TPI ENGLISH ACME SCREW

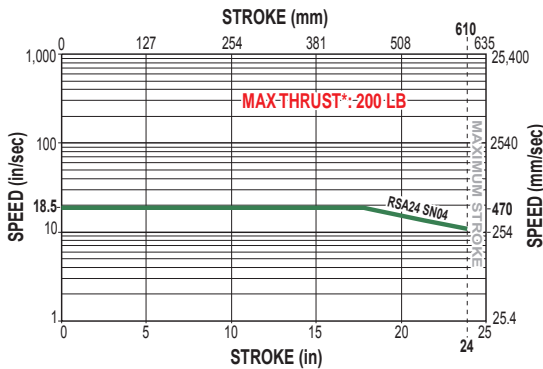

PV LIMITS: 0.625" 4TPI ENGLISH ACME SCREW

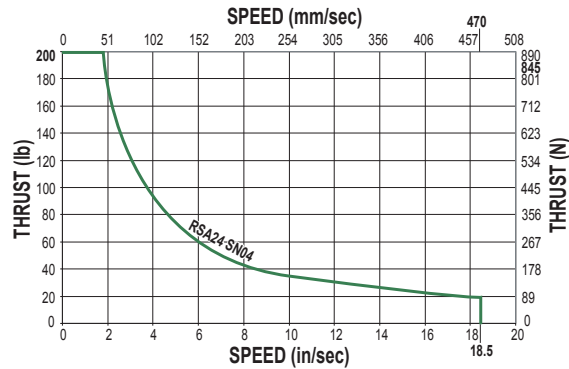

CRITICAL SPEED WITH 0.625" 8TPI ENGLISH ACME SCREW

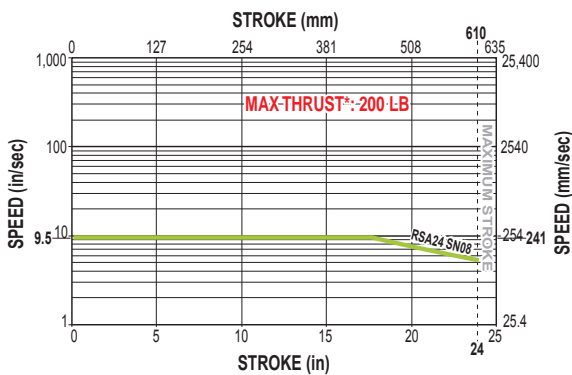

PV LIMITS: 0.625" 8TPI ENGLISH ACME SCREW

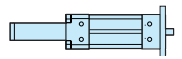
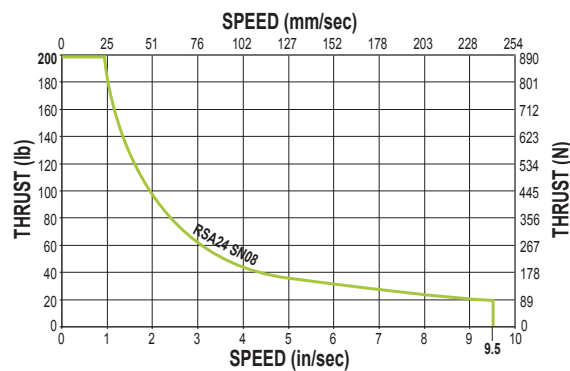

ROD SCREW

RSA/RSM24 Series

- Acme screw critical speed and PV limits

SN = Solid Nut



* Maximum thrust is the maximum continuous dynamic thrust subject to Thrust x Velocity limitation.

PV LIMITS: Any material which carries a sliding load is limited by heat buildup. The factors that affect heat generation rate in an application are the pressure on the nut in pounds per square inch and the surface velocity in feet per minute. The product of these factors provides a measure of the severity of an application.

$$P = \frac{\text{Thrust}}{\text{Max. Thrust Rating}} \times V = \frac{\text{Speed}}{\text{Max. Speed Rating}} \leq 0.1$$

Axi-dyne® RSA/RSM24 Series

ACME AND BALL SCREW SPECIFICATIONS

RSA24 ACME SCREW CRITICAL SPEED AND PV LIMITS (continued)

CRITICAL SPEED WITH 0.625" 10TPI ENGLISH ACME SCREW

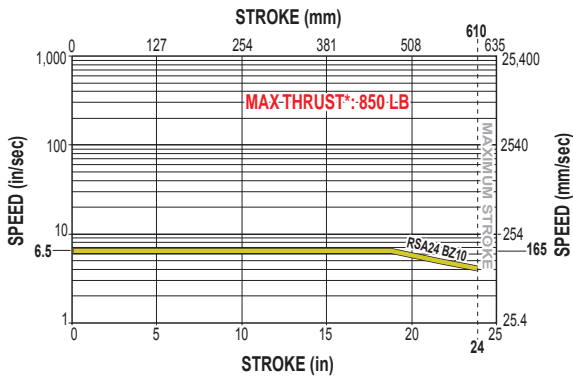

PV LIMITS: 0.625" 10TPI ENGLISH ACME SCREW

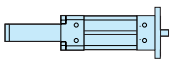
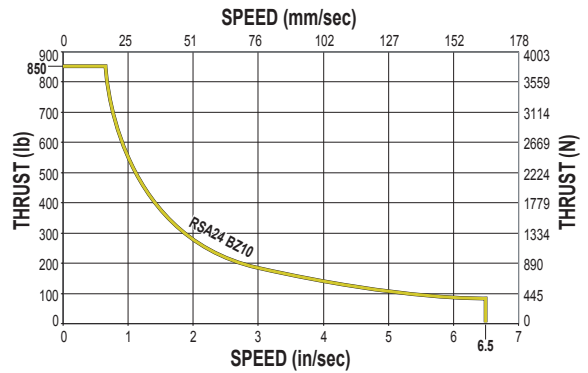

ROD SCREW

RSA/RSM24 Series

- Acme screw critical speed and PV limits
- Ball screw critical speed and life calculations

BZ = Bronze Nut



* *Maximum thrust is the maximum continuous dynamic thrust subject to Thrust x Velocity limitation.*

PV LIMITS: Any material which carries a sliding load is limited by heat buildup. The factors that affect heat generation rate in an application are the pressure on the nut in pounds per square inch and the surface velocity in feet per minute. The product of these factors provides a measure of the severity of an application.

$$P = \frac{\text{Thrust}}{\text{Max. Thrust Rating}} \times V = \frac{\text{Speed}}{\text{Max. Speed Rating}} \leq 0.1$$

RSA24 BALL SCREW CRITICAL SPEED AND LIFE CALCULATIONS

CRITICAL SPEED WITH 0.625" 5TPI ENGLISH BALL SCREW

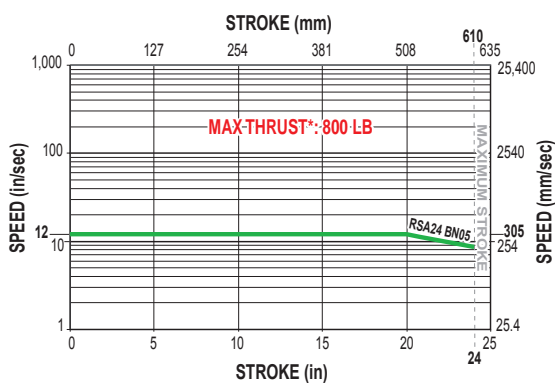

LIFE CALCULATION: 0.625" 5TPI ENGLISH BALL SCREW

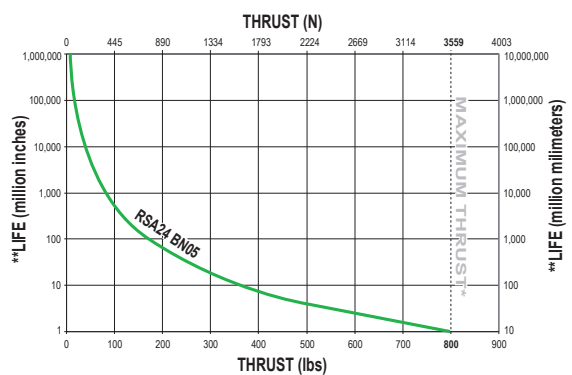

BN = Ball Nut



* *Maximum thrust reflects 90% reliability for 1 million linear inches of travel.*

**Life indicates theoretical maximum life of screw only, under ideal conditions and does not indicate expected life of actuator.

Axi dyne® RSA/RSM24 Series

DIMENSIONS

RSA/RSM24 IN-LINE (LMI) BASE MODEL OPTIONS AND SWITCH MOUNTING

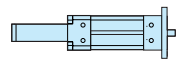
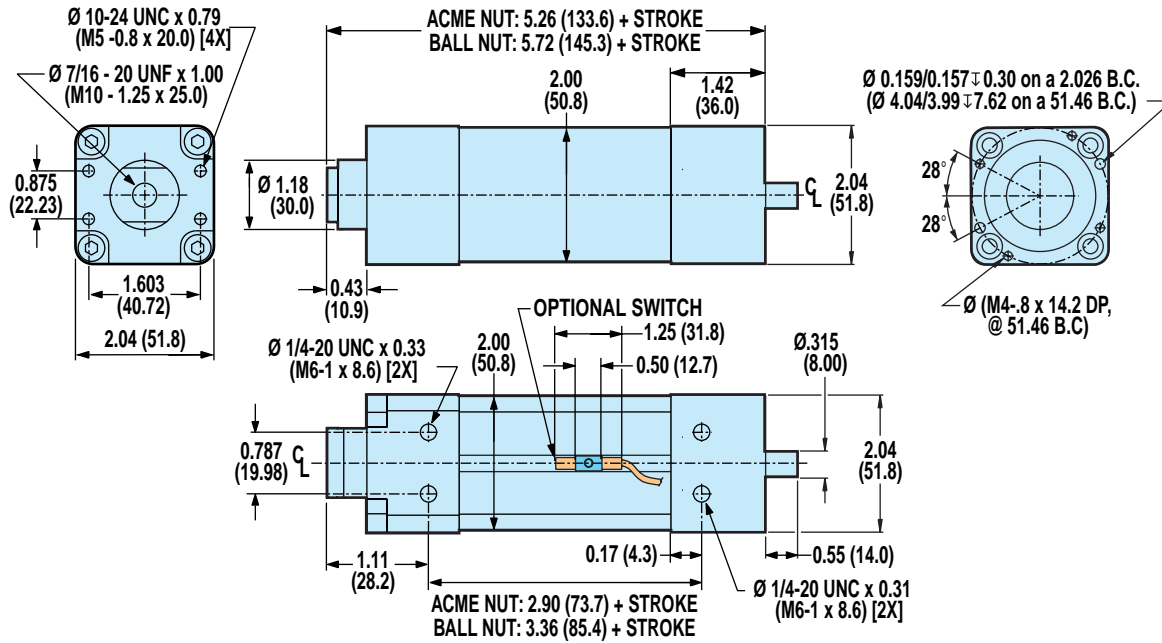

ROD SCREW

- RSA/RSM24 Series**
- In-line base model and switch mounting dimensions

OPTIONAL TRUNNION MOUNT: TRN

⚠ TRUNNION MOUNTS ARE NOT FIELD RETROFITTABLE AND MUST BE CONFIGURED AS PART OF THE BASE ACTUATOR. CONTACT THE FACTORY FOR ADDITIONAL INFORMATION.

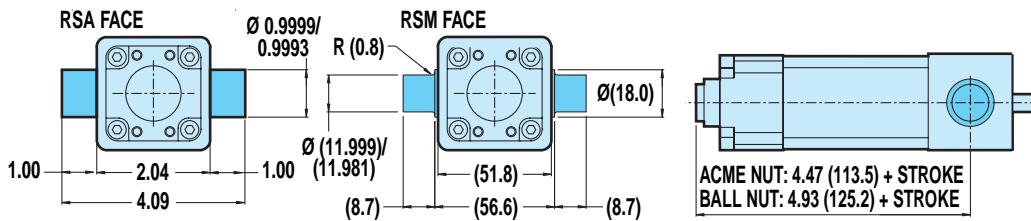

OPTIONAL SWITCH MOUNTING ⚠Ⓜ

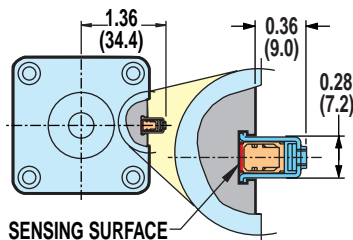

⚠ CAUTION: DO NOT OVERTIGHTEN SWITCH HARDWARE WHEN INSTALLING

Ⓜ NOTE: The scored face of the switch indicates the sensing surface and must face toward the magnet

Unless otherwise noted, all dimensions shown are in inches (Dimensions in parenthesis are in millimeters)

Axi dyne® RSA/RSM24 Series

DIMENSIONS

RSA/RSM24 REVERSE PARALLEL (RP) BASE MODEL OPTIONS AND SWITCH MOUNTING

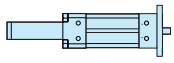

ROD SCREW

RSA/RSM24 Series

- Reverse parallel base model dimensions

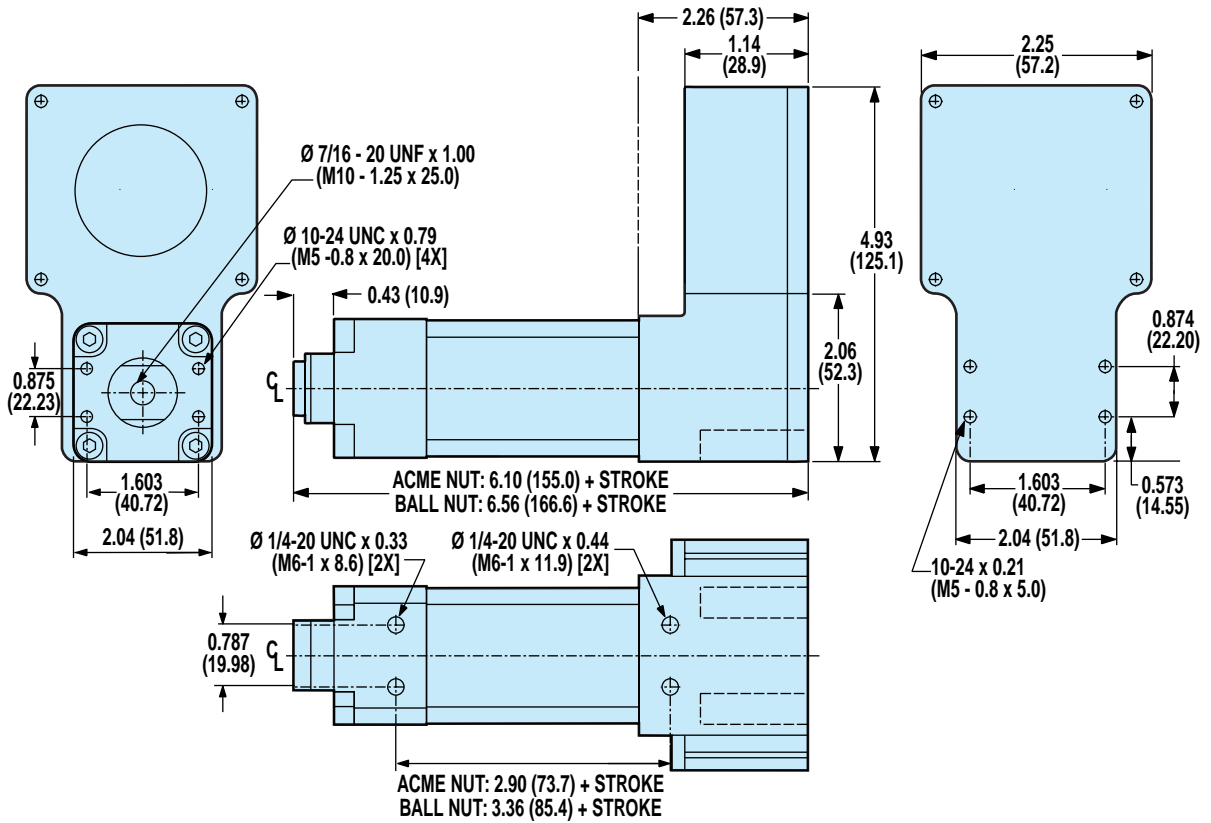

OPTIONAL TRUNNION MOUNT: TRN

- ⚠ TRUNNION MOUNTS ARE NOT FIELD RETROFITTABLE AND MUST BE CONFIGURED AS PART OF THE BASE ACTUATOR. CONTACT THE FACTORY FOR ADDITIONAL INFORMATION.**

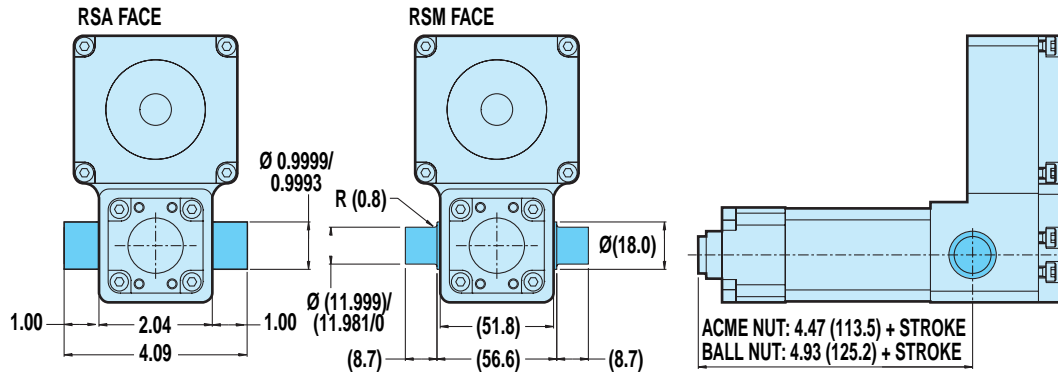

OPTIONAL SWITCH MOUNTING

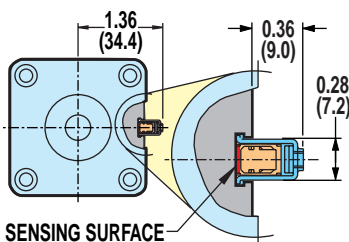

⚠ CAUTION: DO NOT OVERTIGHTEN SWITCH HARDWARE WHEN INSTALLING

Ⓜ NOTE: The scored face of the switch indicates the sensing surface and must face toward the magnet

Axi dyne® RSA/RSM24 Series

DIMENSIONS

RSA/RSM24 RETROFITTABLE ROD END OPTIONS

FOR IN-LINE (LMI) OR REVERSE PARALLEL (RP) MODELS

OPTIONAL Spherical Rod Eye End: SRE

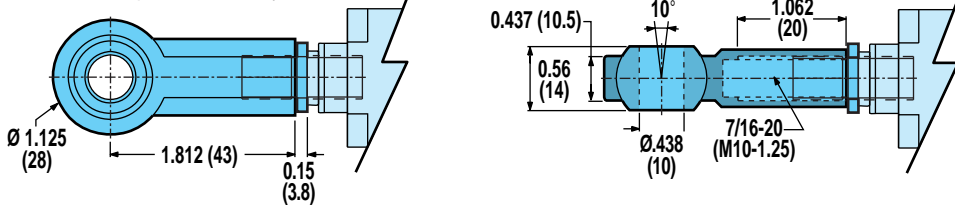

OPTIONAL Alignment Coupler Rod End: ALC

INTERNALLY THREADED END SPECIFIED

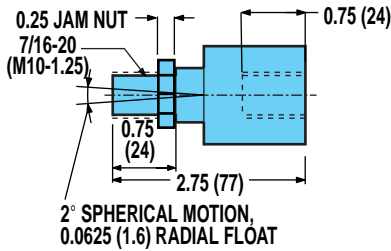

EXTERNALLY THREADED END SPECIFIED

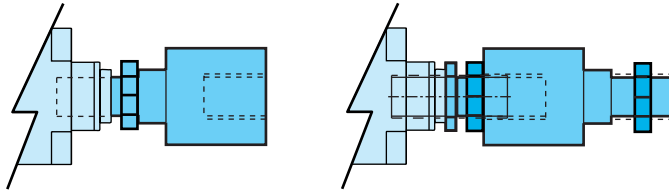
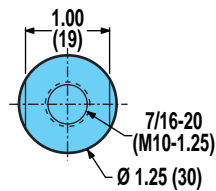
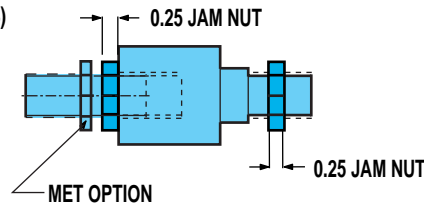

! THE ALIGNMENT COUPLER COMES WITH AN INTERNAL THREAD. IF AN EXTERNAL THREAD IS PREFERRED, THE ADDITION OF THE "MET" OPTION IS REQUIRED.

OPTIONAL External Threaded Rod End: MET

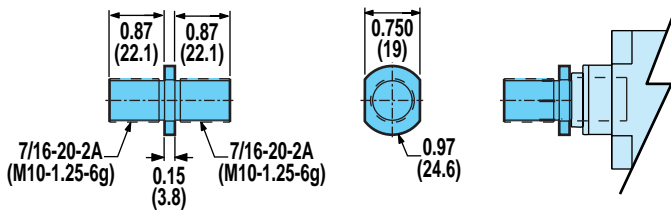

OPTIONAL Clevis Rod End: CLV

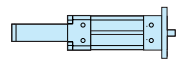
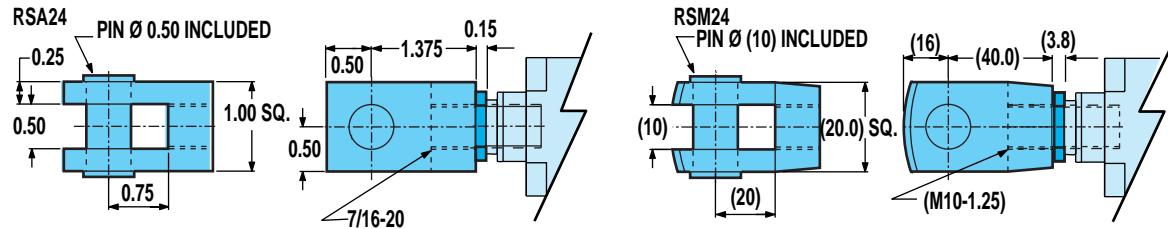

ROD SCREW

RSA/RSM24 Series

- Retrofittable rod end options

Axi dyne® RSA/RSM24 Series

DIMENSIONS

RSA/RSM24 RETROFITTABLE MOUNTING OPTIONS

FOR REVERSE PARALLEL (RP) MODELS ONLY

OPTIONAL Clevis Mount: PCD

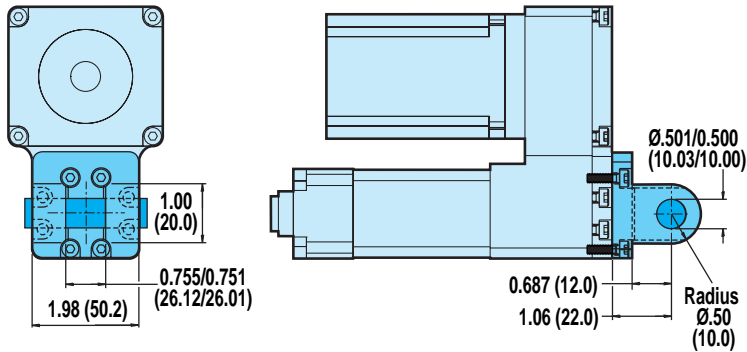

OPTIONAL Eye Mount: PCS

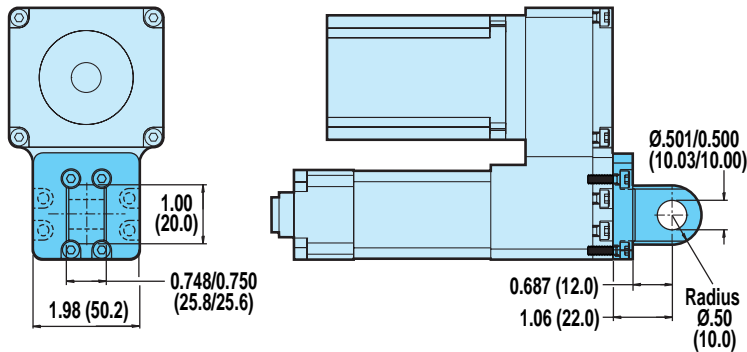

OPTIONAL Foot Mount: FM2

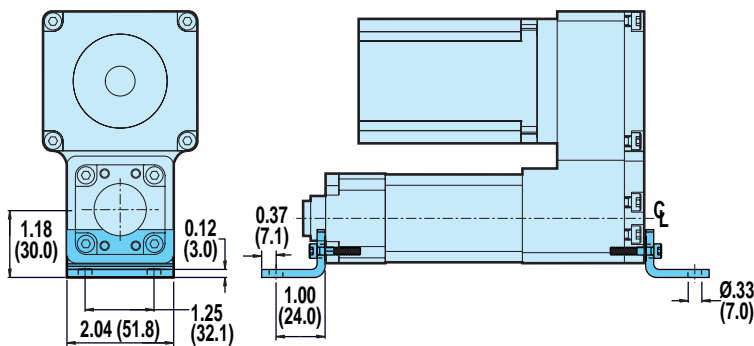

OPTIONAL Back Flange: BFG

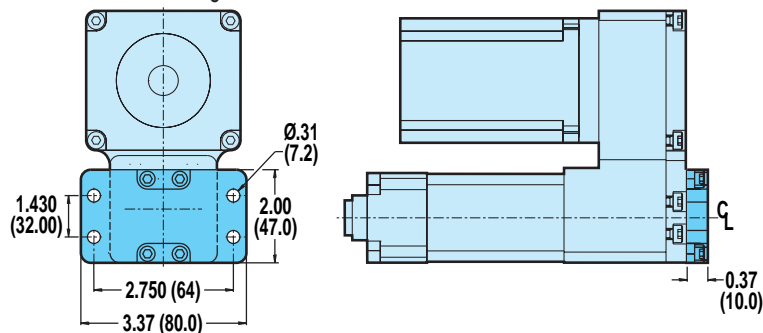

FOR IN-LINE (LMI) OR REVERSE PARALLEL (RP) MODELS

OPTIONAL Mounting Plate: MP2

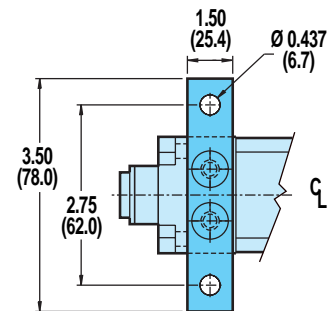
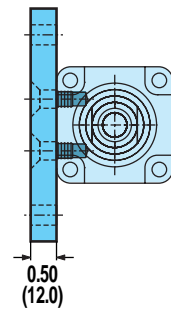

OPTIONAL Front Flange Mount: FFG

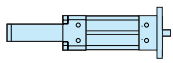
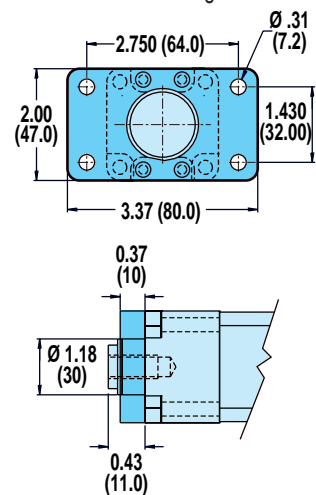

ROD SCREW

RSA/RSM24 Series

- Retrofittable mounting options

Axi dyne® RSA/RSM24 Series

DIMENSIONS

RSA/RSM24: IN-LINE MOUNTING FOR 23-FRAME MOTORS AND GEARHEADS

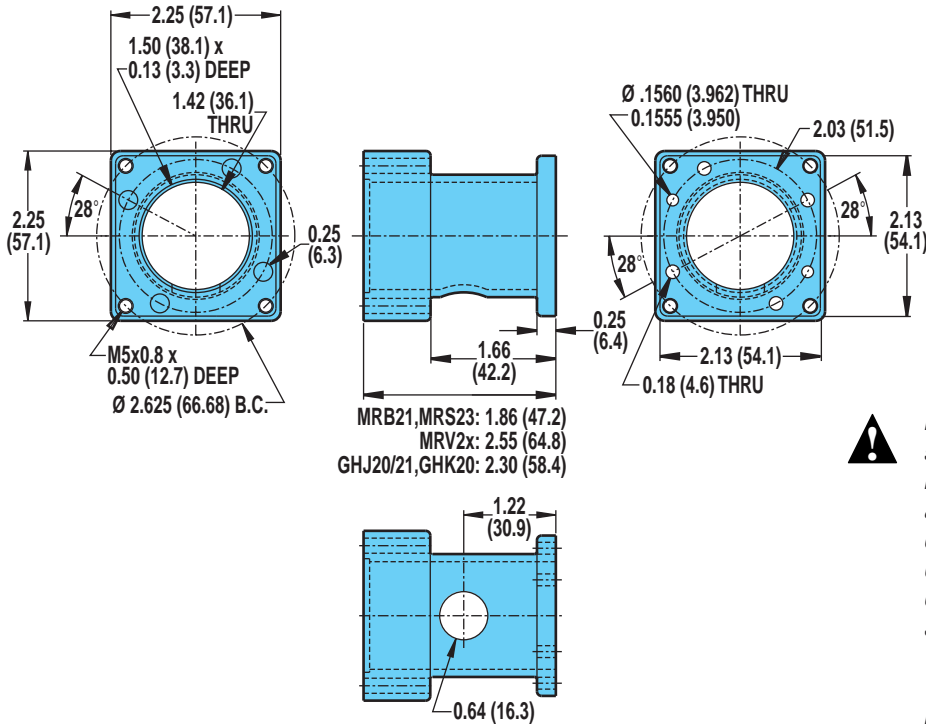

For a complete part listing of screw-drive motor and gearhead mounting kits referencing actuator/motor/coupler compatibilities, refer to document 3600-4631 available on the Literature/Part Sheet/Axidyne section of our web site at: www.tolomatic.com. For gearhead specifications and dimensions, see page F-10.

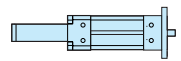

ROD SCREW

RSA/RSM24 Series

- In-line motor mounting
- Reverse parallel motor mounting

RSA/RSM24: REVERSE PARALLEL MOTOR MOUNTING

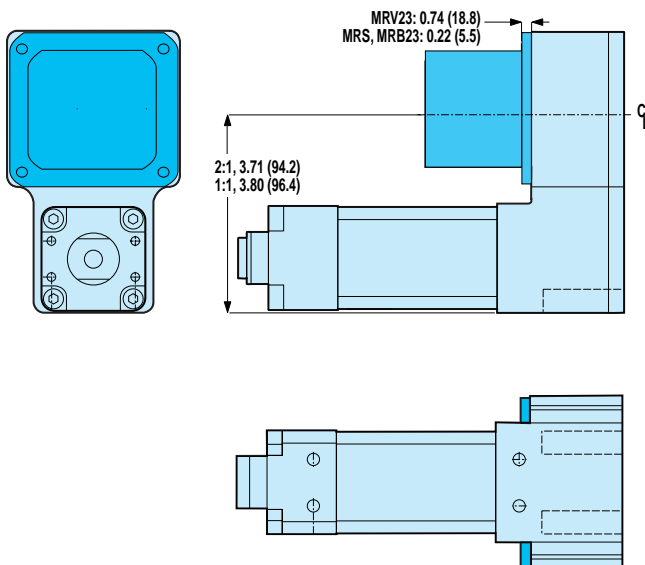

SPECIFICATIONS

MOTOR	REDUCTION INERTIA AT MOTOR SHAFT			
	1:1		2:1	
	lb-in ²	kg-m ² x 10 ⁻⁴	lb-in ²	kg-m ² x 10 ⁻⁴
BRUSHLESS MRV21, 22, 23, 24	0.008	2.320	0.029	8.599
STEPPER MRS231, 232	0.009	2.559	0.030	8.848
BRUSHED MRB21	0.009	2.564	0.030	8.843

REDUCTION EFFICIENCY: 0.95



Axi-dyne[®]

RSA/RSM32 Series ACME SCREW SPECIFICATIONS

RSA32 ACME SCREW CRITICAL SPEED AND PV LIMITS

CRITICAL SPEED WITH 0.75" 1TPI ENGLISH ACME SCREW

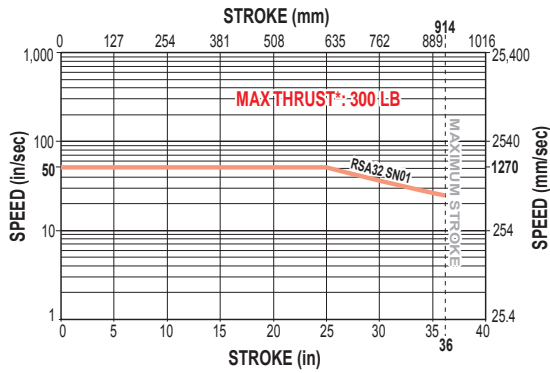

PV LIMITS: 0.75" 1TPI ENGLISH ACME SCREW

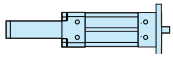
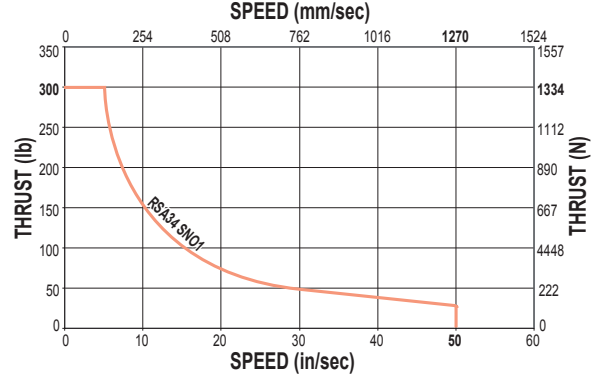

ROD SCREW

RSA/RSM32 Series

- Acme screw critical speed and PV limits

CRITICAL SPEED WITH 0.75" 2TPI ENGLISH ACME SCREW

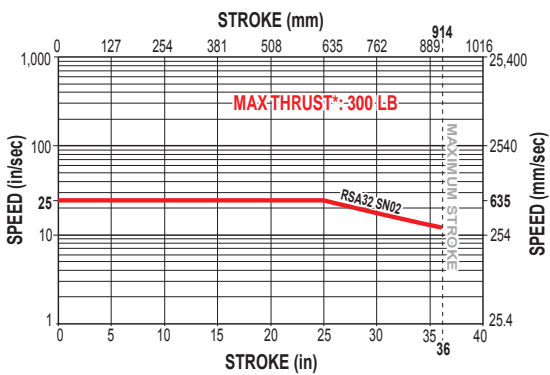

PV LIMITS: 0.75" 2TPI ENGLISH ACME SCREW

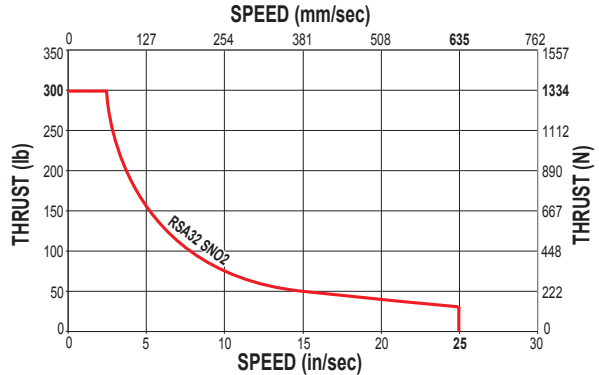

CRITICAL SPEED WITH 0.75" 10TPI ENGLISH ACME SCREW

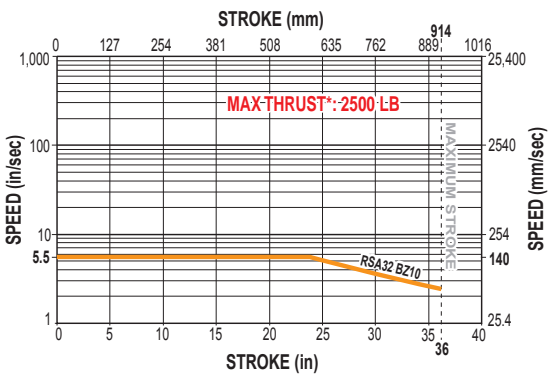

PV LIMITS: 0.75" 10TPI ENGLISH ACME SCREW

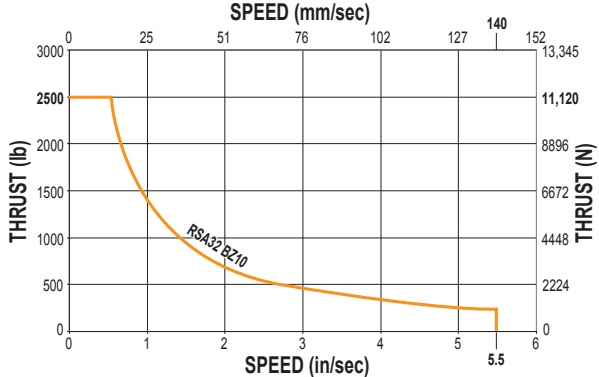

SN = Solid Nut BZ= Bronze Nut



** Maximum thrust is the maximum continuous dynamic thrust subject to Thrust x Velocity limitation.*

PV LIMITS: Any material which carries a sliding load is limited by heat buildup. The factors that affect heat generation rate in an application are the pressure on the nut in pounds per square inch and the surface velocity in feet per minute. The product of these factors provides a measure of the severity of an application.

$$P = \frac{\text{Thrust}}{\text{Max. Thrust Rating}} \times V = \frac{\text{Speed}}{\text{Max. Speed Rating}} \leq 0.1$$

Axi-dyne® RSA/RSM32 Series

BALL SCREW SPECIFICATIONS

RSA32 BALL SCREW CRITICAL SPEED AND LIFE CALCULATIONS

CRITICAL SPEED WITH 0.75" 2TPI ENGLISH BALL SCREW

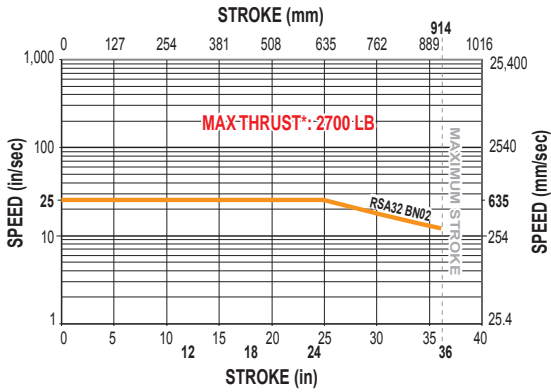

LIFE CALCULATION: 0.75" 2TPI ENGLISH BALL SCREW

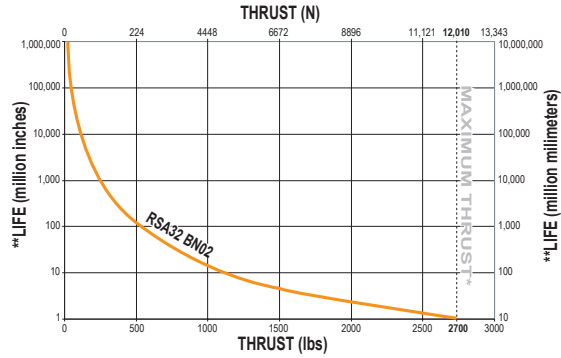

ROD SCREW

RSA/RSM32 Series

- Ball screw critical speed and life calculations

CRITICAL SPEED WITH 0.75" 5TPI ENGLISH BALL SCREW

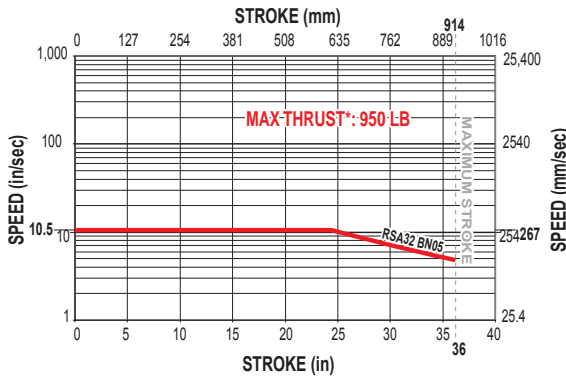

LIFE CALCULATION: 0.75" 5TPI ENGLISH BALL SCREW

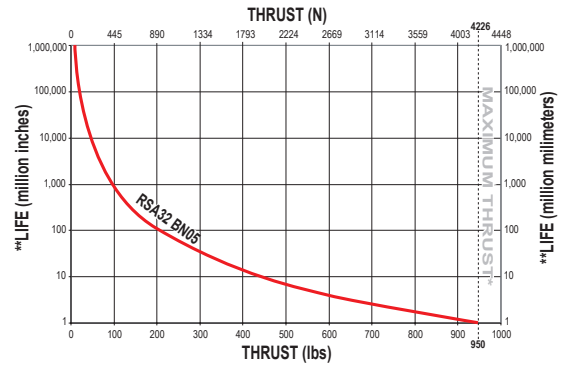

BN = Ball Nut



* Maximum thrust reflects 90% reliability for 1 million linear inches of travel.

**Life indicates theoretical maximum life of screw only, under ideal conditions and does not indicate expected life of actuator.

Axi-dyne® RSA/RSM32 Series

DIMENSIONS

RSA/RSM32 IN-LINE (LMI) BASE MODEL OPTIONS AND SWITCH MOUNTING

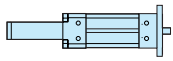
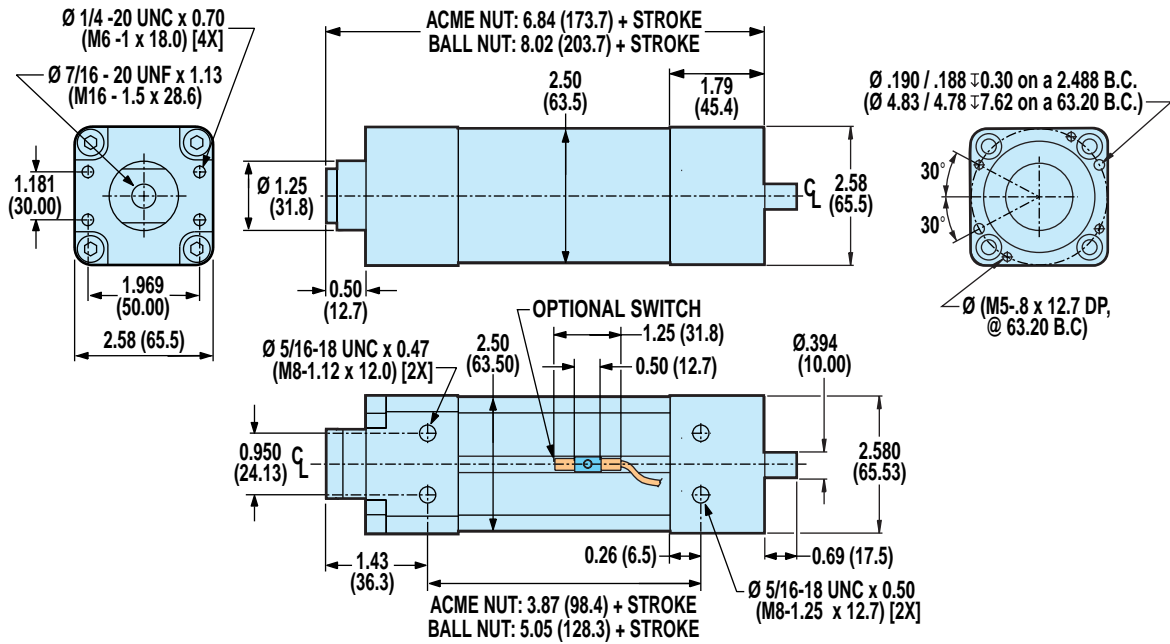

ROD SCREW

RSA/RSM32 Series

- In-line base model and switch mounting dimensions

OPTIONAL TRUNNION MOUNT: TRN

⚠ TRUNNION MOUNTS ARE NOT FIELD RETROFITTABLE AND MUST BE CONFIGURED AS PART OF THE BASE ACTUATOR. CONTACT THE FACTORY FOR ADDITIONAL INFORMATION.

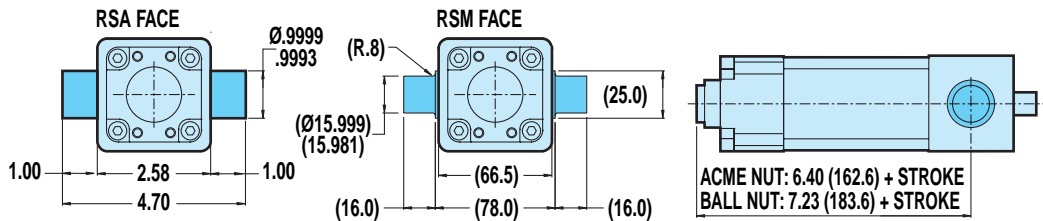

OPTIONAL SWITCH MOUNTING **⚠**

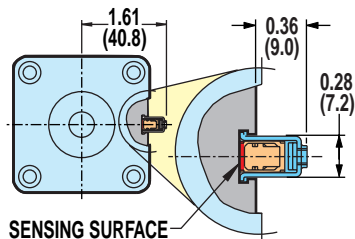

⚠ CAUTION: DO NOT OVERTIGHTEN SWITCH HARDWARE WHEN INSTALLING

Ⓜ NOTE: The scored face of the switch indicates the sensing surface and must face toward the magnet

Unless otherwise noted, all dimensions shown are in inches (Dimensions in parenthesis are in millimeters)

Axi dyne® RSA/RSM32 Series

DIMENSIONS

RSA/RSM32 REVERSE PARALLEL (RP) BASE MODEL OPTIONS AND SWITCH MOUNTING

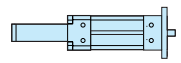
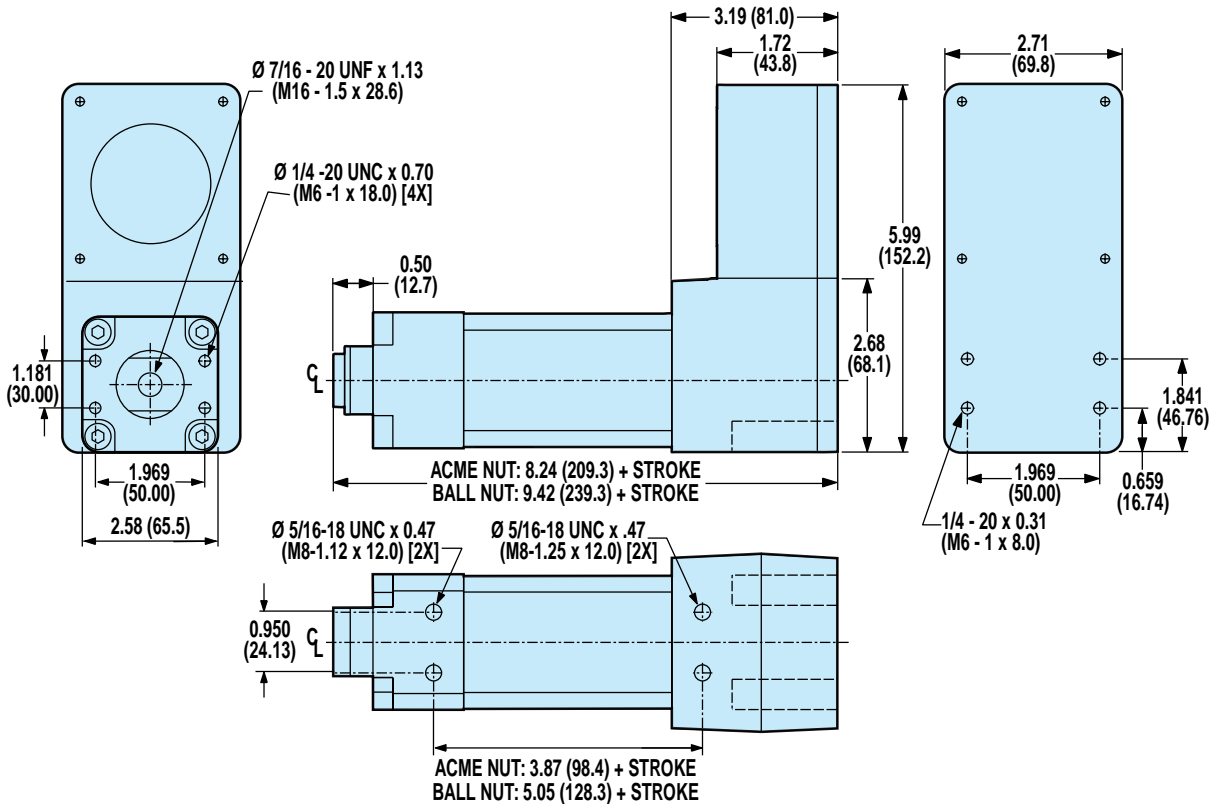

ROD SCREW

RSA/RSM32 Series

- Reverse parallel base model and switch mounting dimensions

OPTIONAL TRUNNION MOUNT: TRN

⚠ TRUNNION MOUNTS ARE NOT FIELD RETROFITTABLE AND MUST BE CONFIGURED AS PART OF THE BASE ACTUATOR. CONTACT THE FACTORY FOR ADDITIONAL INFORMATION.

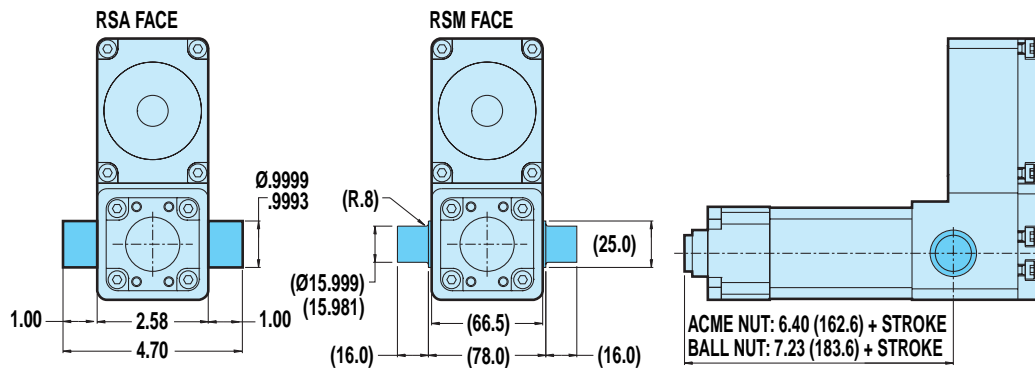

OPTIONAL SWITCH MOUNTING ¹⚠ ²

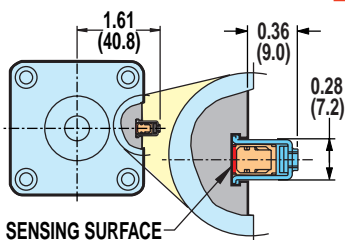

- ⚠ CAUTION: DO NOT OVERTIGHTEN SWITCH HARDWARE WHEN INSTALLING**
- 2** NOTE: The scored face of the switch indicates the sensing surface and must face toward the magnet

Axi dyne® RSA/RSM32 Series

DIMENSIONS

RSA/RSM32 RETROFITTABLE ROD END OPTIONS

FOR IN-LINE (LMI) OR REVERSE PARALLEL (RP) MODELS

OPTIONAL Spherical Rod Eye End: SRE

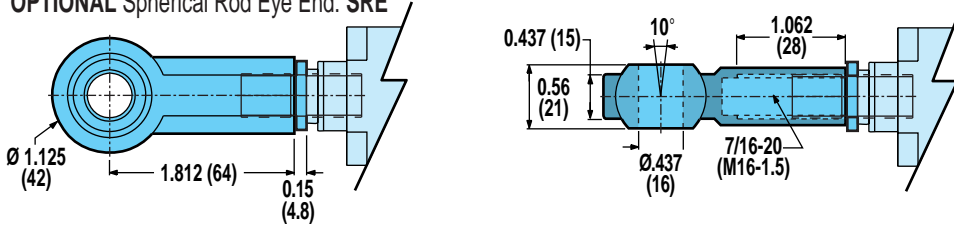

OPTIONAL Alignment Coupler Rod End: ALC

INTERNALLY THREADED END SPECIFIED

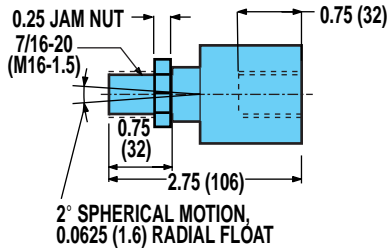

EXTERNALLY THREADED END SPECIFIED

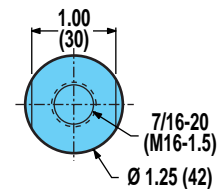
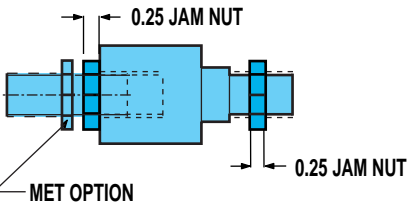

! THE ALIGNMENT COUPLER COMES WITH AN INTERNAL THREAD. IF AN EXTERNAL THREAD IS PREFERRED, THE ADDITION OF THE "MET" OPTION IS REQUIRED.

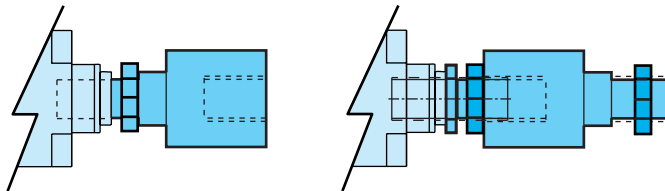

OPTIONAL External Threaded Rod End: MET

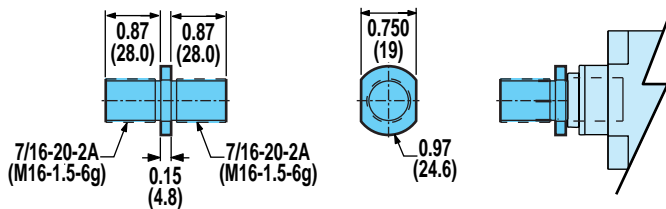

OPTIONAL Clevis Rod End: CLV

RSA32 PIN Ø 0.50 INCLUDED

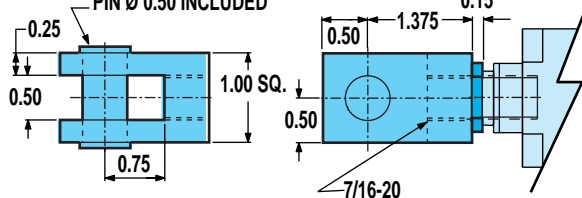

RSM32 PIN Ø (16) INCLUDED

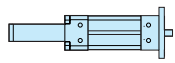
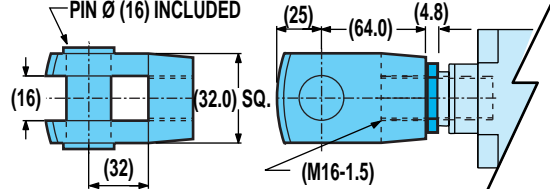

ROD SCREW

RSA/RSM32 Series

- Retrofittable rod end options dimensions

Axi dyne® RSA/RSM32 Series

DIMENSIONS

RSA/RSM32 RETROFITTABLE MOUNTING OPTIONS

FOR REVERSE PARALLEL (RP) MODELS ONLY

OPTIONAL Clevis Mount: PCD

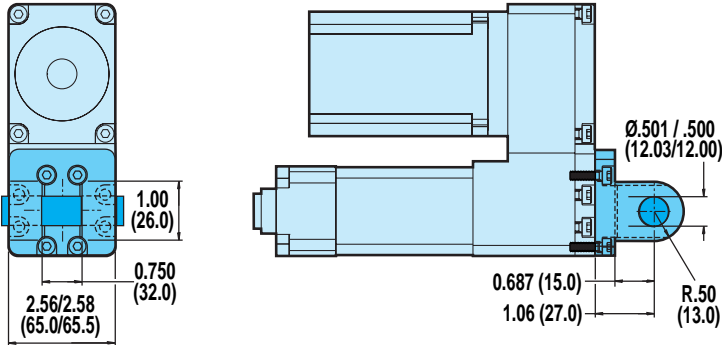

OPTIONAL Eye Mount: PCS

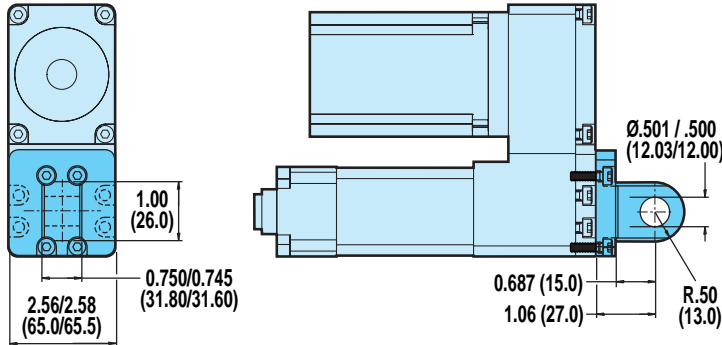

OPTIONAL Foot Mount: FM2

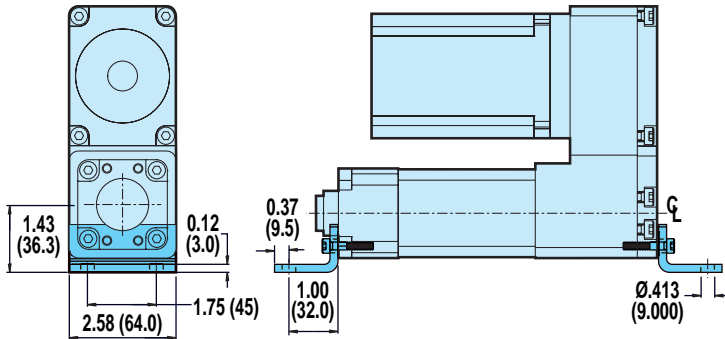

OPTIONAL Back Flange: BFG

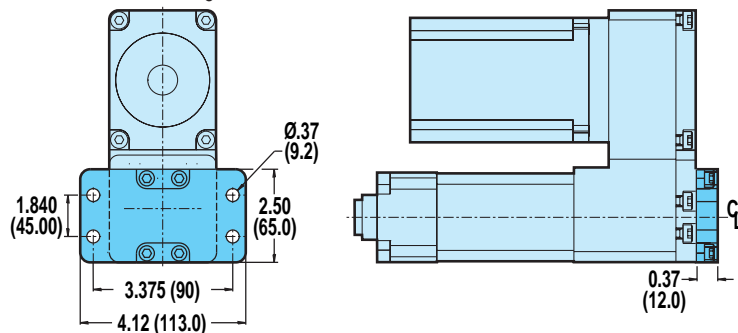

FOR IN-LINE (LMI) OR REVERSE PARALLEL (RP) MODELS

OPTIONAL Mounting Plate: MP2

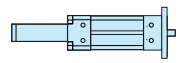
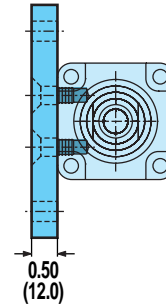

ROD SCREW

RSA/RSM32 Series

- Retrofittable mounting options dimensions

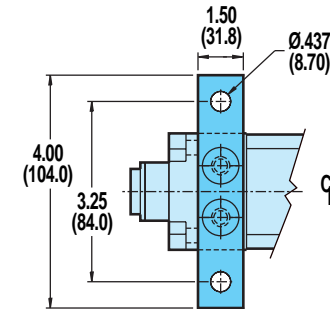

OPTIONAL Front Flange Mount: FFG

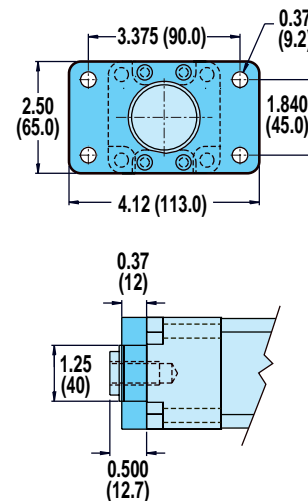

Axi dyne® RSA/RSM32 Series

DIMENSIONS

RSA/RSM32: IN-LINE MOUNTING MOTORS AND GEARHEADS

FRAME	MOTOR	GEARHEAD	A	B	C	D	E
			in (mm)	in (mm)	in (mm)	in (mm)	in (mm)
23	MRV	NO	2.63 (66.8)	2.63 (66.8)	1.50 (38.1)	2.625 (66.68)	1.505 (38.23)
23	ALL	YES	2.38 (60.5)	2.63 (66.8)	1.50 (38.1)	2.625 (66.68)	1.505 (38.23)
23	MRS, MRB	NO	2.00 (50.8)	2.25 (57.2)	1.50 (38.1)	2.625 (66.68)	1.505 (38.23)
34	ALL	with or without	2.38 (60.5)	3.75 (95.3)	1.70 (43.2)	3.875 (98.43)	2.880 (73.15)
40	MRB	NO	3.56 (90.4)	4.00 (101.6)	1.70 (43.2)	3.250 (82.55)	2.505 (63.63)

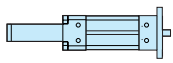

ROD SCREW

RSA/RSM32 Series

- In-line motor mounting
- Reverse parallel motor mounting

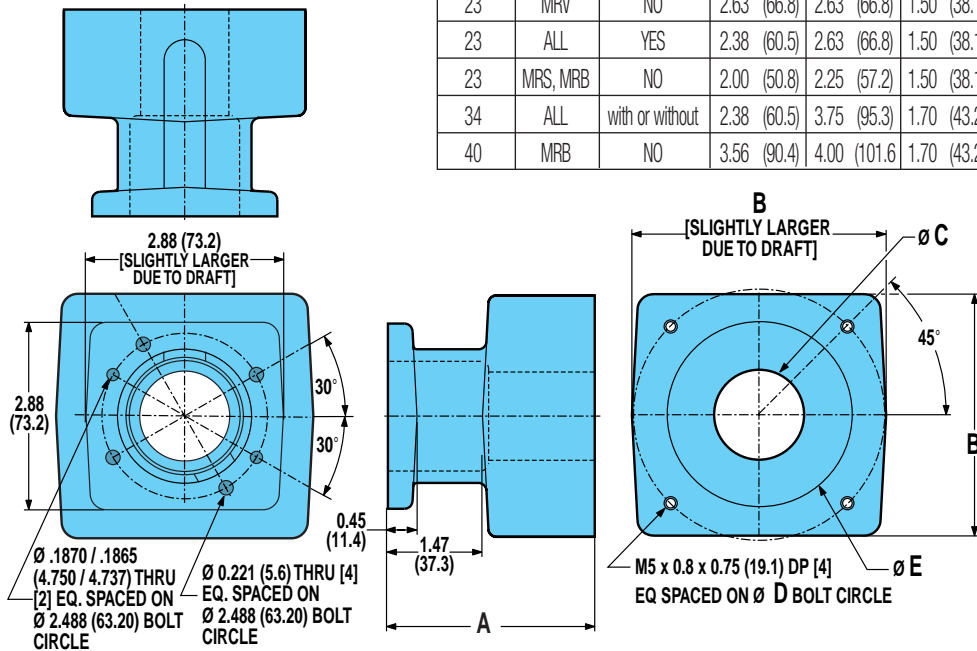

For a complete part listing of screw-drive motor and gearhead mounting kits referencing actuator/motor/coupler compatibilities, refer to document 3600-4631 available on the Literature/Part Sheet/Axidyne section of our web site at: www.tolomatic.com. For gearhead specifications and dimensions, see page F-10.

RSA/RSM32: REVERSE PARALLEL MOTOR MOUNTING

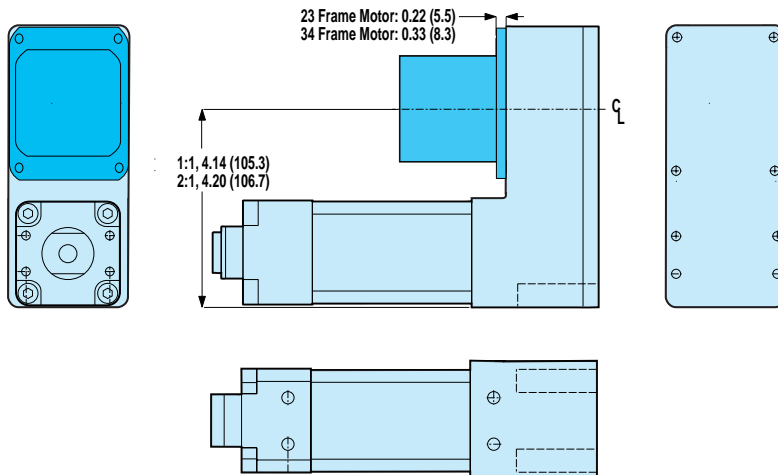

SPECIFICATIONS

MOTOR	REDUCTION INERTIA AT MOTOR SHAFT				
	1:1		2:1		
	lb-in ²	kg-m ² x 10 ⁻⁶	lb-in ²	kg-m ² x 10 ⁻⁶	
BRUSHLESS	MRV21, 22, 23, 24	0.467	13.650	0.144	42.256
	MRV31, 32, 33	0.467	13.650	0.144	42.256
STEPPER	MRS231, 232	0.467	13.650	0.144	42.256
	MRS341, 343, 343	0.467	13.650	0.144	42.256
BRUSHED	MRB21	0.467	13.650	0.144	42.256
	MRB31, 32, 33	0.467	13.650	0.144	42.256
	MRB42	0.467	13.650	0.144	42.256

REDUCTION EFFICIENCY: 0.95

Axi-dyne® RSA/RSM50 Series

ACME SCREW SPECIFICATIONS



RSA50 ACME SCREW CRITICAL SPEED AND PV LIMITS

CRITICAL SPEED WITH 1.0" 4TPI ENGLISH ACME SCREW

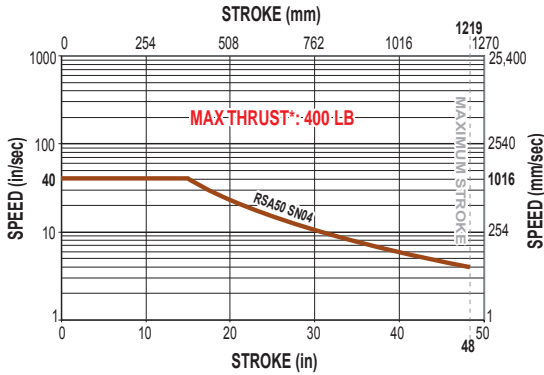

PV LIMITS: 1.0" 4TPI ENGLISH ACME SCREW

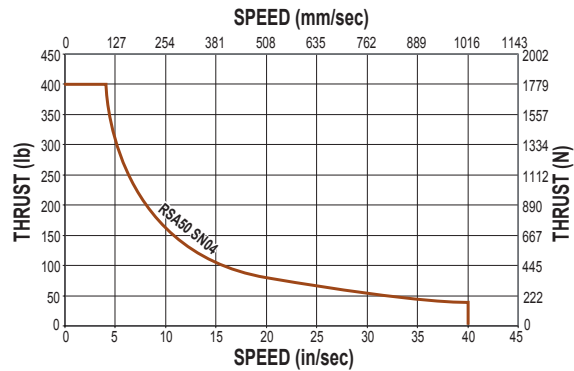

CRITICAL SPEED WITH 1.0" 10TPI ENGLISH ACME SCREW

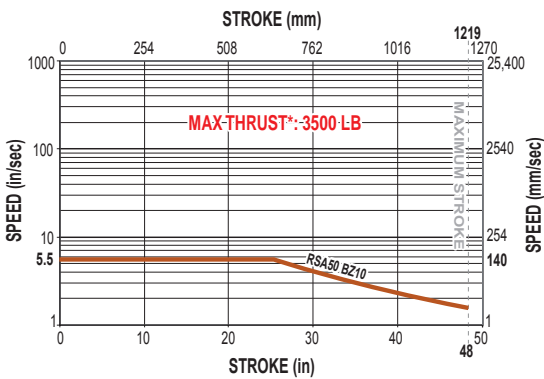

PV LIMITS: 1.0" 10TPI ENGLISH ACME SCREW

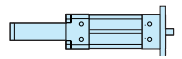
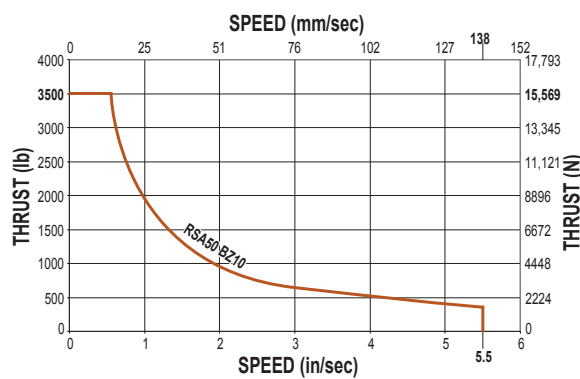

ROD SCREW

RSA/RSM50 Series

- Acme screw critical speed and PV limits

SN = Solid Nut BZ= Bronze Nut



* Maximum thrust is the maximum continuous dynamic thrust subject to Thrust x Velocity limitation.

PV LIMITS: Any material which carries a sliding load is limited by heat buildup. The factors that affect heat generation rate in an application are the pressure on the nut in pounds per square inch and the surface velocity in feet per minute. The product of these factors provides a measure of the severity of an application.

$$P = \frac{\text{Thrust}}{\text{Max. Thrust Rating}} \times V = \frac{\text{Speed}}{\text{Max. Speed Rating}} \leq 0.1$$

Axi-dyne® RSA/RSM50 Series

BALL SCREW SPECIFICATIONS

RSA50 BALL SCREW CRITICAL SPEED AND LIFE CALCULATIONS

CRITICAL SPEED WITH 1.0" ITPI ENGLISH BALL SCREW

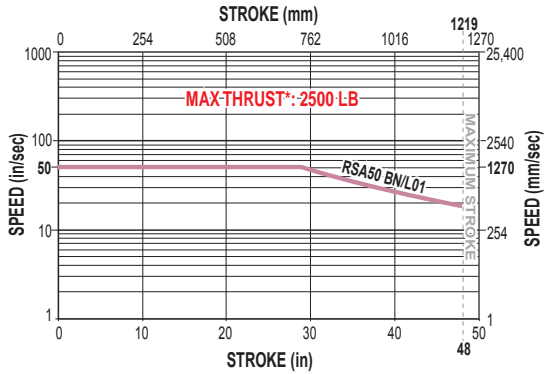

LIFE CALCULATION: 1.0" ITPI ENGLISH BALL SCREW

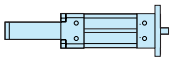
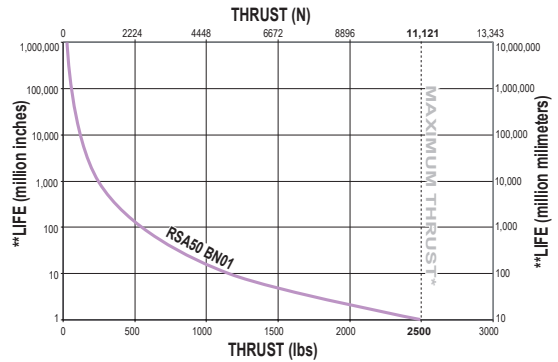

ROD SCREW

RSA/RSM50 Series

- Ball screw critical speed and life calculations

CRITICAL SPEED WITH 1.0" 2TPI ENGLISH BALL SCREW

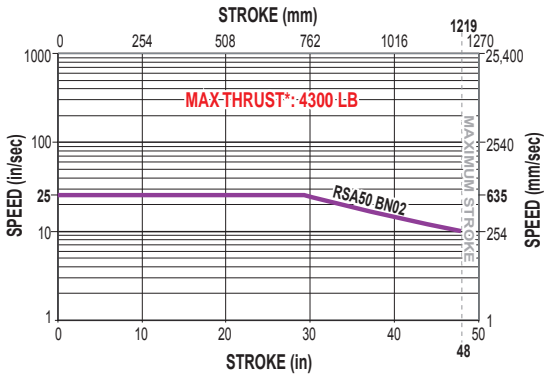

LIFE CALCULATION: 1.0" 2TPI ENGLISH BALL SCREW

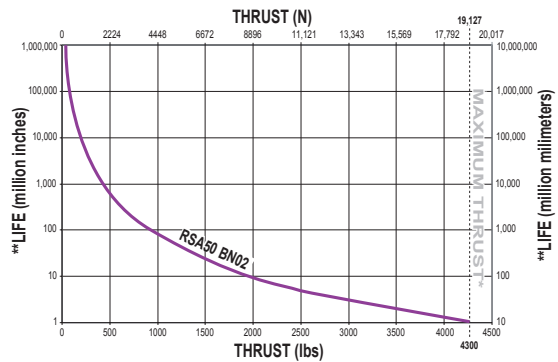

CRITICAL SPEED WITH 1.0" 4TPI ENGLISH BALL SCREW

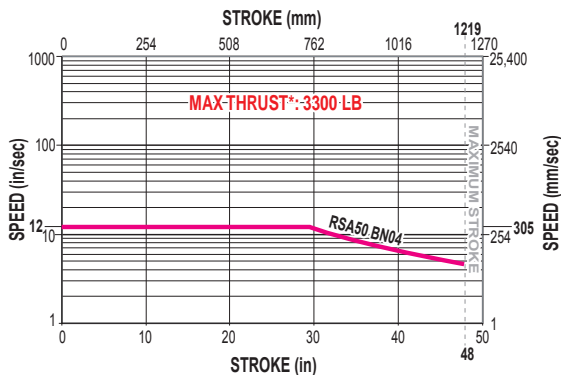

LIFE CALCULATION: 1.0" 4TPI ENGLISH BALL SCREW

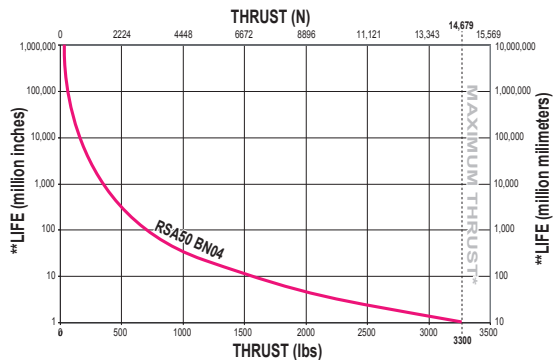

BN = Ball Nut



* Maximum thrust reflects 90% reliability for 1 million linear inches of travel.

** Life indicates theoretical maximum life of screw only, under ideal conditions and does not indicate expected life of actuator.

Axi dyne® RSA/RSM50 Series

DIMENSIONS

RSA/RSM50 IN-LINE (LMI) BASE MODEL OPTIONS AND SWITCH MOUNTING

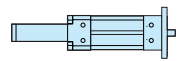
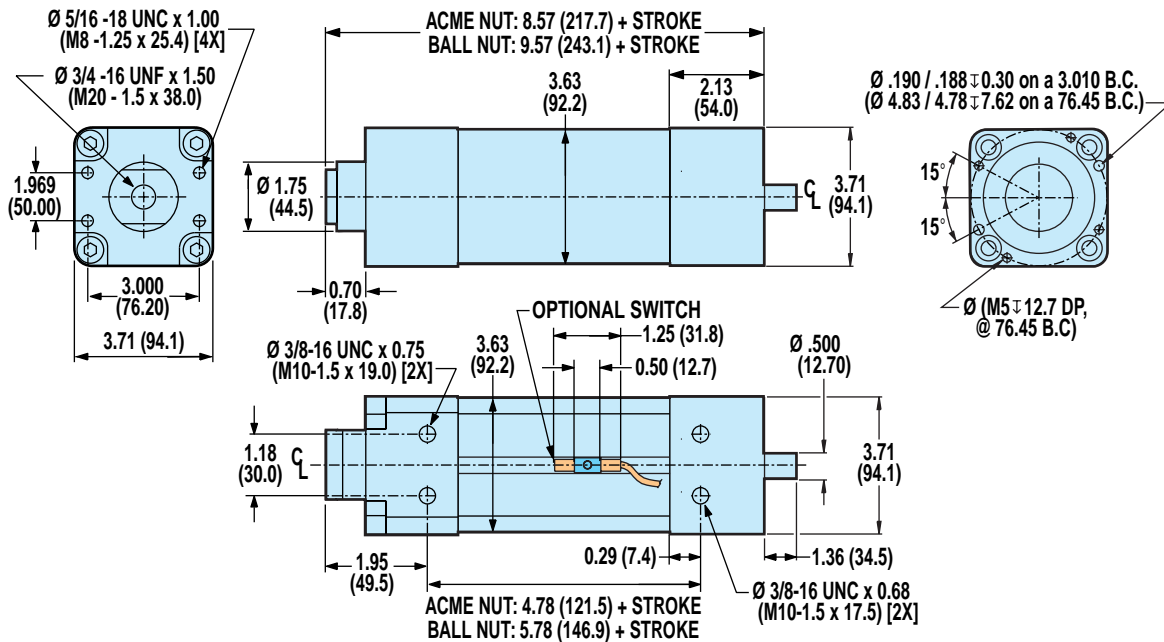

ROD SCREW

RSA/RSM50 Series

- In-line base model and switch mounting dimensions

OPTIONAL TRUNNION MOUNT: TRN

TRUNNION MOUNTS ARE NOT FIELD RETROFITTABLE AND MUST BE CONFIGURED AS PART OF THE BASE ACTUATOR. CONTACT THE FACTORY FOR ADDITIONAL INFORMATION.

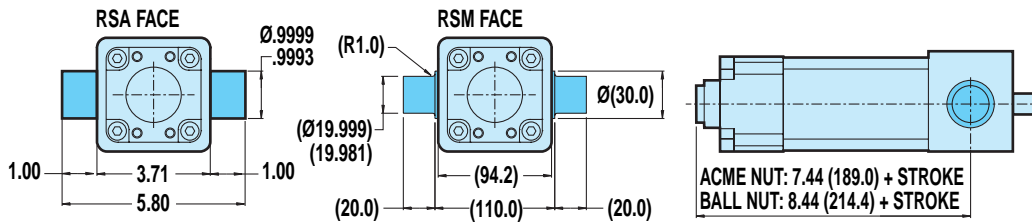

OPTIONAL SWITCH MOUNTING ¹ ²

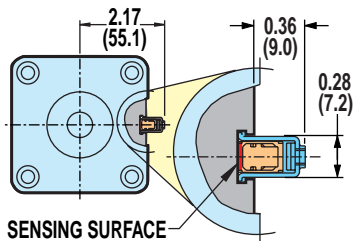

- CAUTION: DO NOT OVERTIGHTEN SWITCH HARDWARE WHEN INSTALLING**
- NOTE:** The scored face of the switch indicates the sensing surface and must face toward the magnet

Unless otherwise noted, all dimensions shown are in inches (Dimensions in parenthesis are in millimeters)

Axi-dyne® RSA/RSM50 Series

DIMENSIONS

RSA/RSM50 REVERSE PARALLEL (RP) BASE MODEL OPTIONS AND SWITCH MOUNTING

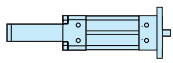

ROD SCREW

RSA/RSM50 Series

- Reverse parallel base model and switch mounting dimensions

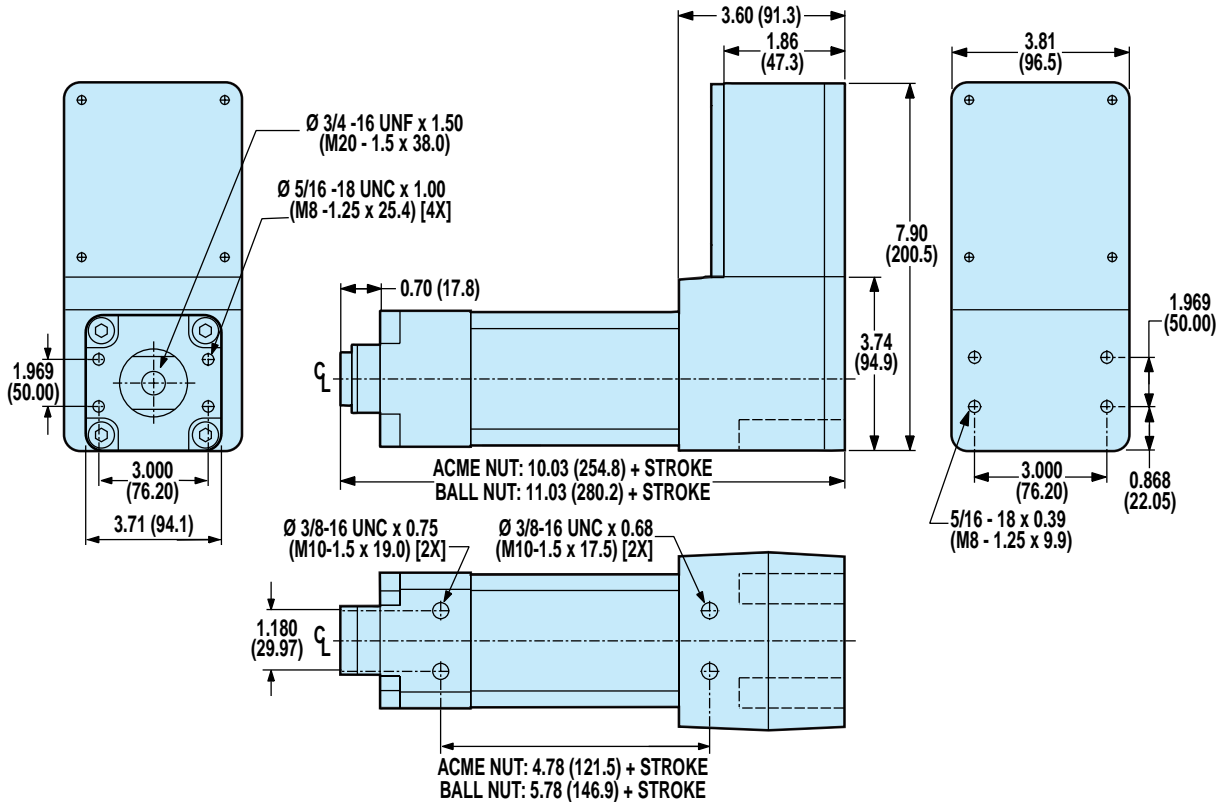

OPTIONAL TRUNNION MOUNT: TRN

- ⚠ TRUNNION MOUNTS ARE NOT FIELD RETROFITTABLE AND MUST BE CONFIGURED AS PART OF THE BASE ACTUATOR. CONTACT THE FACTORY FOR ADDITIONAL INFORMATION.

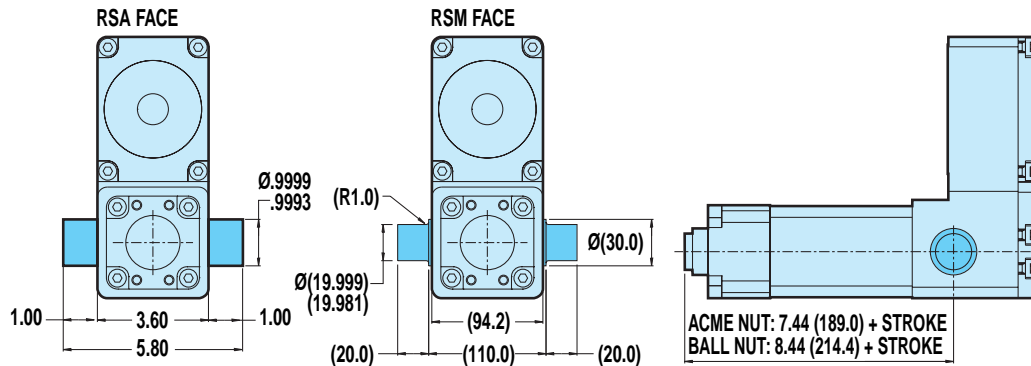

OPTIONAL SWITCH MOUNTING ⚠Ⓜ

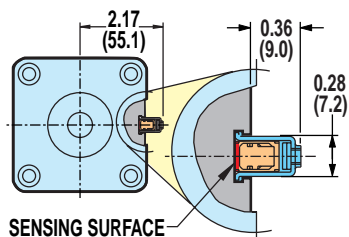

- ⚠ CAUTION: DO NOT OVERTIGHTEN SWITCH HARDWARE WHEN INSTALLING
- Ⓜ NOTE: The scored face of the switch indicates the sensing surface and must face toward the magnet

Axi-dyne® RSA/RSM50 Series

DIMENSIONS

RSA/RSM50 RETROFITTABLE ROD END OPTIONS

FOR IN-LINE (LMI) OR REVERSE PARALLEL (RP) MODELS

OPTIONAL Spherical Rod Eye End: SRE

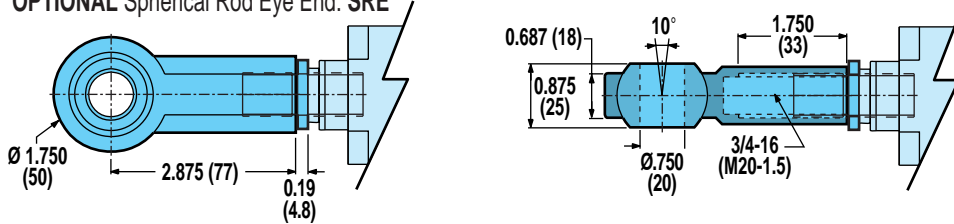

OPTIONAL Alignment Coupler Rod End: ALC

INTERNALLY THREADED END SPECIFIED

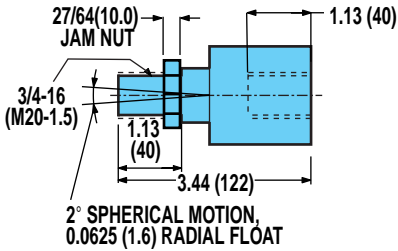

EXTERNALLY THREADED END SPECIFIED

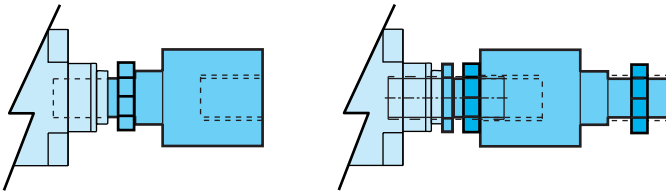
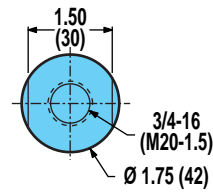
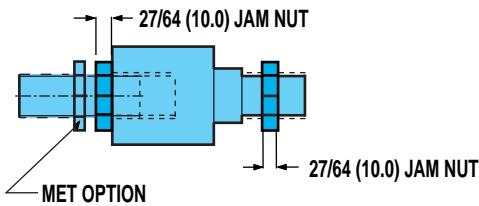

! THE ALIGNMENT COUPLER COMES WITH AN INTERNAL THREAD. IF AN EXTERNAL THREAD IS PREFERRED, THE ADDITION OF THE "MET" OPTION IS REQUIRED.

OPTIONAL External Threaded Rod End: MET

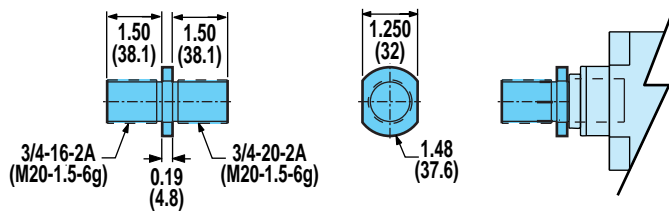

OPTIONAL Clevis Rod End: CLV

RSA32 PIN $\varnothing 0.75$ INCLUDED

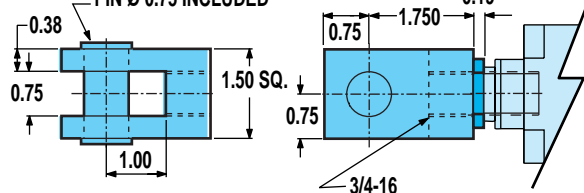

RSM32 PIN $\varnothing (20)$ INCLUDED

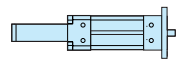
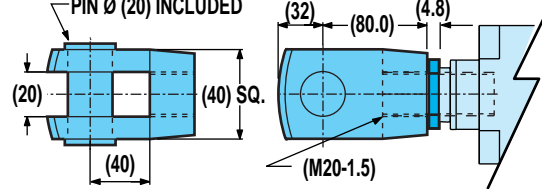

ROD SCREW

RSA/RSM50 Series

- Retrofittable rod end options

Axi dyne® RSA/RSM50 Series

DIMENSIONS

RSA/RSM50 RETROFITTABLE MOUNTING OPTIONS

FOR REVERSE PARALLEL (RP) MODELS ONLY

OPTIONAL Clevis Mount: PCD (for use on RP models only)

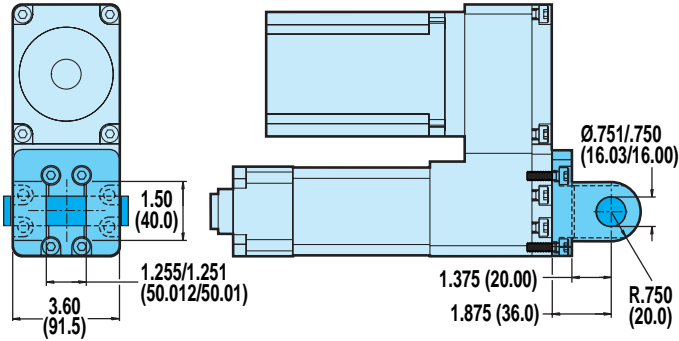

OPTIONAL Eye Mount: PCS (for use on RP models only)

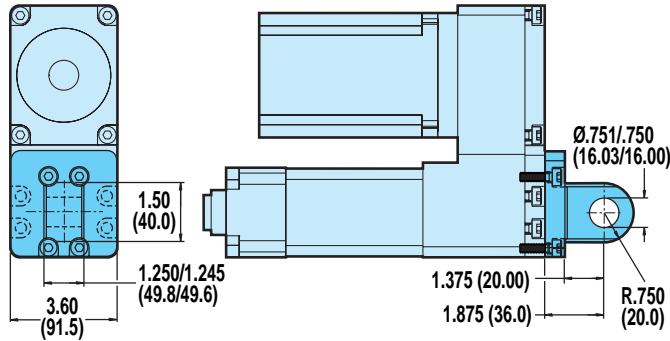

OPTIONAL Foot Mount: FM2 (for use on RP models only)

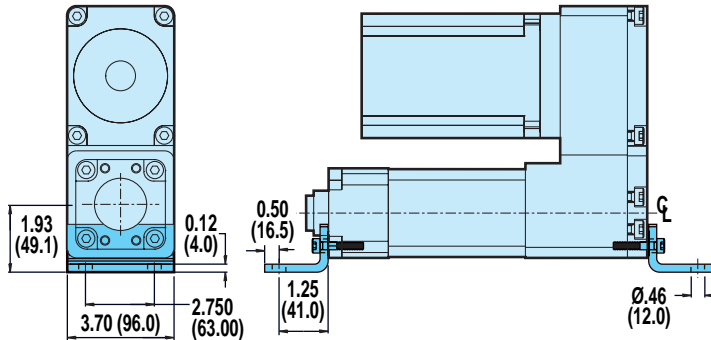

OPTIONAL Back Flange: BFG (for use on RP models only)

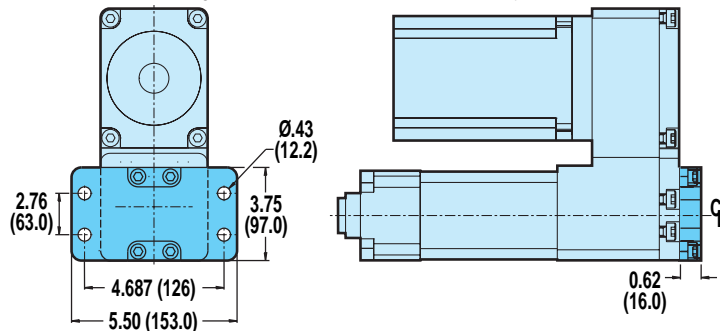

FOR IN-LINE (LMI) OR REVERSE PARALLEL (RP) MODELS

OPTIONAL Mounting Plate: MP2

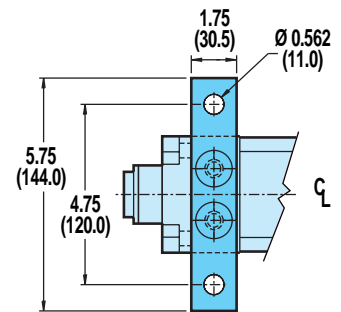
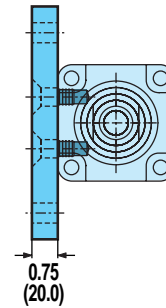

OPTIONAL Front Flange Mount: FFG

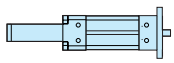
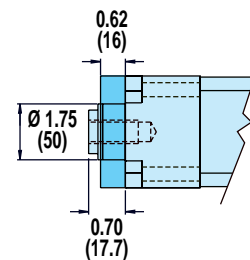
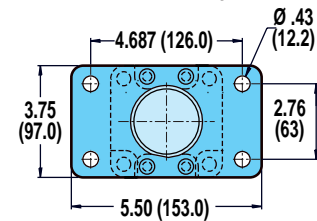

ROD SCREW

RSA/RSM50 Series

- Retrofittable mounting options

Axi dyne® RSA/RSM50 Series

DIMENSIONS

RSA/RSM50: IN-LINE MOUNTING MOTORS AND GEARHEADS

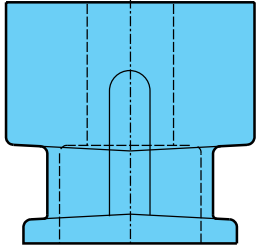

FRAME	MOTOR	GEARHEAD	A	B	C	D	E
			in (mm)	in (mm)	in (mm)	in (mm)	in (mm)
23	MRV	NO	3.30 (83.8)	3.00 (76.2)	1.50 (38.1)	1.505 (38.23)	2.625 (66.6)
23	MRV	YES	3.05 (63.5)	3.00 (76.2)	1.50 (38.1)	1.505 (38.23)	2.625 (66.6)
34	ALL	NO	3.05 (63.5)	3.75 (95.2)	2.25 (57.2)	2.880 (73.15)	3.875 (98.4)
34	ALL	YES	3.83 (97.2)	3.75 (95.2)	2.25 (57.2)	2.880 (73.15)	3.875 (98.4)
40	MRB	NO	4.23 (107.4)	3.75 (95.2)	2.25 (57.2)	2.505 (63.63)	3.25 (82.55)
56	MRV	NO	4.48 (77.4)	3.75 (95.2)	2.25 (57.2)	4.505 (114.43)	5.875 (149.23)

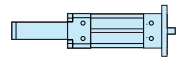
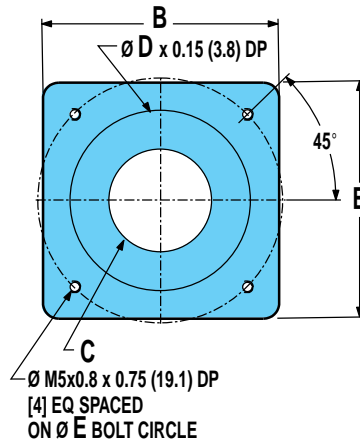
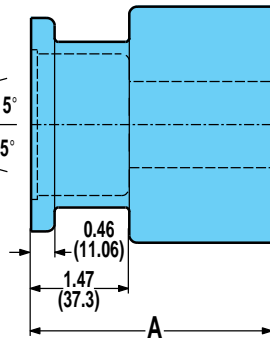
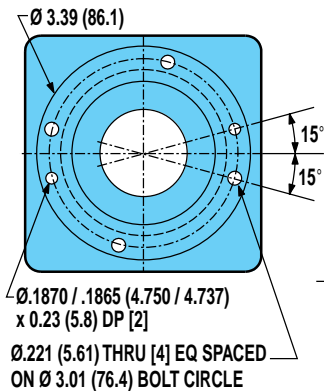

ROD SCREW

RSA/RSM50 Series

- In-line mounting motors and gearheads
- Reverse parallel motor mounting



For a complete part listing of screw-drive motor and gearhead mounting kits referencing actuator/motor/coupler compatibilities, refer to document 3600-4631 available on the Literature/Part Sheet/Axidyne section of our web site at: www.tolomatic.com.
For gearhead specifications and dimensions, see page F-10.

RSA/RSM50: REVERSE PARALLEL MOTOR MOUNTING

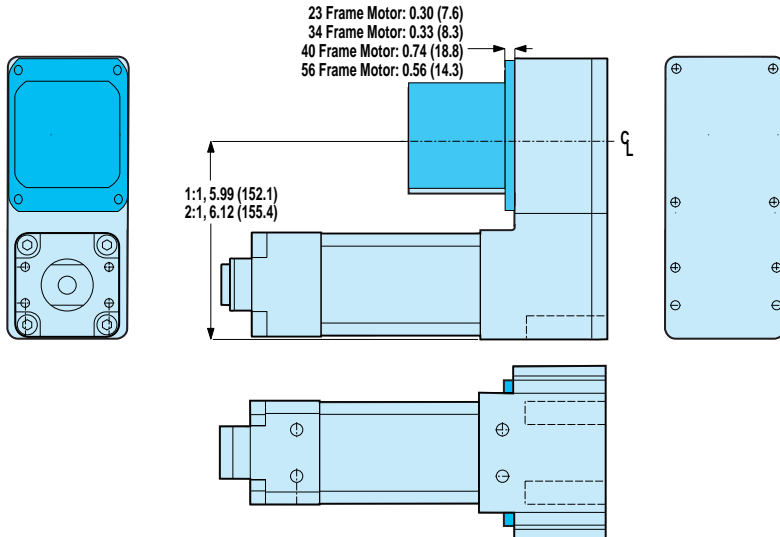

SPECIFICATIONS

MOTOR	REDUCTION INERTIA AT MOTOR SHAFT				
	1:1		2:1		
	lb-in ²	kg-m ² x 10 ⁻⁴	lb-in ²	kg-m ² x 10 ⁻⁴	
BRUSHLESS	MRV21, 22, 23, 24	0.276	80.672	0.821	240.086
	MRV31, 32, 33	0.816	80.675	2.429	240.088
	MRV51	0.826	241.692	2.516	735.913
STEPPER	MRS341, 343, 343	0.809	236.551	2.421	708.156
BRUSHED	MRB31, 32, 33	0.809	236.551	2.421	708.156
	MRB41, 42	0.904	264.309	2.516	735.913

REDUCTION EFFICIENCY: 0.95



Axi
dyne[®]

RSA/RSM 64 Series ACME SCREW SPECIFICATIONS

RSA64 ACME SCREW CRITICAL SPEED AND PV LIMITS

CRITICAL SPEED WITH 1.5" 4TPI ENGLISH ACME SCREW

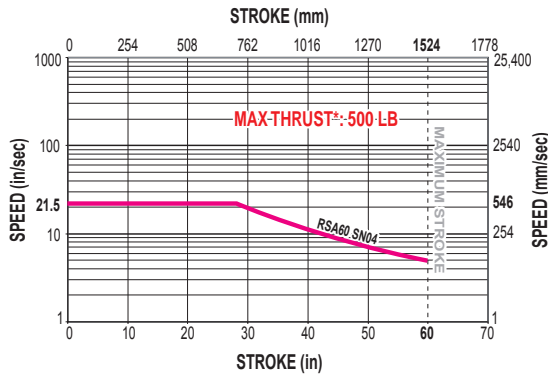

PV LIMITS: 1.5" 4TPI ENGLISH ACME SCREW

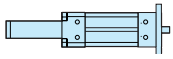
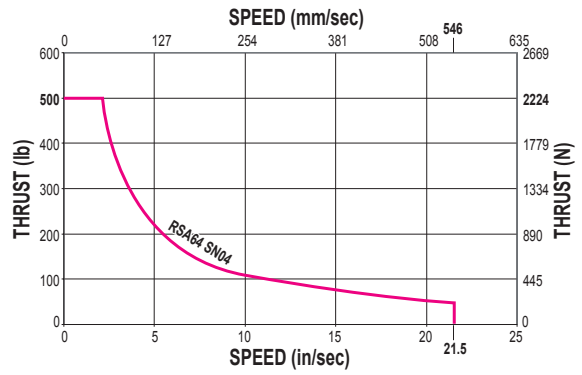

ROD SCREW

RSA/RSM64 Series

- Acme screw critical speed and PV limits

CRITICAL SPEED WITH 1.5" 10TPI ENGLISH ACME SCREW

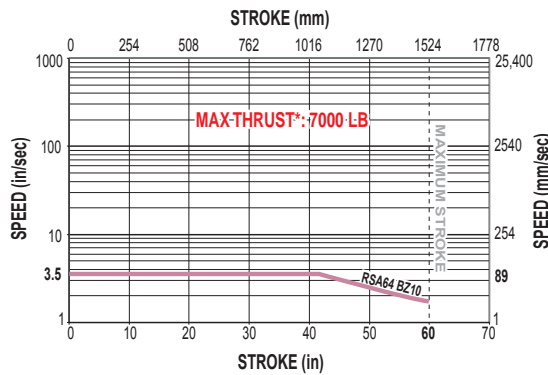

PV LIMITS: 1.5" 10TPI ENGLISH ACME SCREW

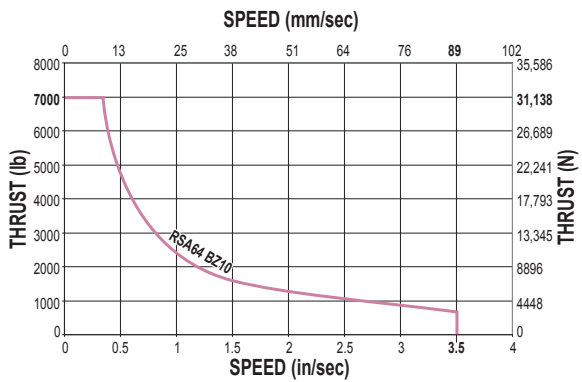

SN = Solid Nut BZ= Bronze Nut



* *Maximum thrust is the maximum continuous dynamic thrust subject to Thrust x Velocity limitation.*

PV LIMITS: Any material which carries a sliding load is limited by heat buildup. The factors that affect heat generation rate in an application are the pressure on the nut in pounds per square inch and the surface velocity in feet per minute. The product of these factors provides a measure of the severity of an application.

$$P = \frac{\text{Thrust}}{\text{Max. Thrust Rating}} \times V = \frac{\text{Speed}}{\text{Max. Speed Rating}} \leq 0.1$$

Axi-dyne® RSA/RSM64 Series

BALL SCREW SPECIFICATIONS

RSA64 BALL SCREW CRITICAL SPEED AND LIFE CALCULATIONS

CRITICAL SPEED WITH 1.5" 0.53TPI ENGLISH BALL SCREW

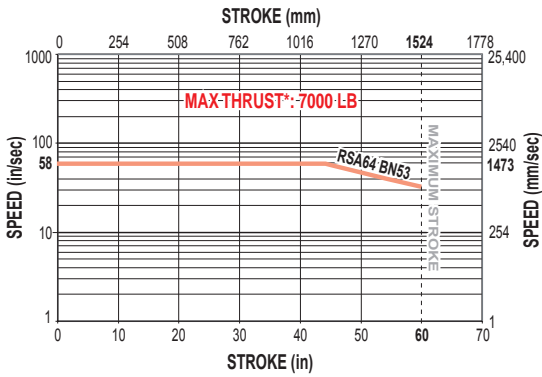

LIFE CALCULATION: 1.5" 0.53TPI ENGLISH BALL SCREW

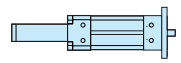
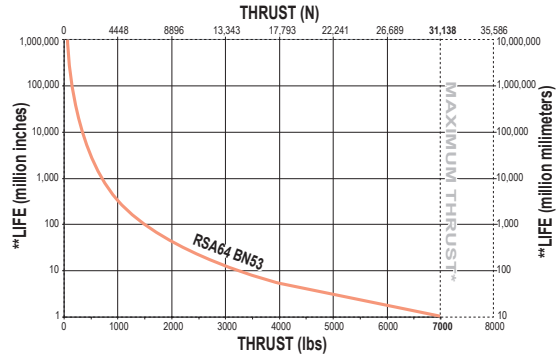

ROD SCREW

RSA/RSM64 Series

- Ball screw critical speed and life calculations

CRITICAL SPEED WITH 1.5" 2TPI ENGLISH BALL SCREW

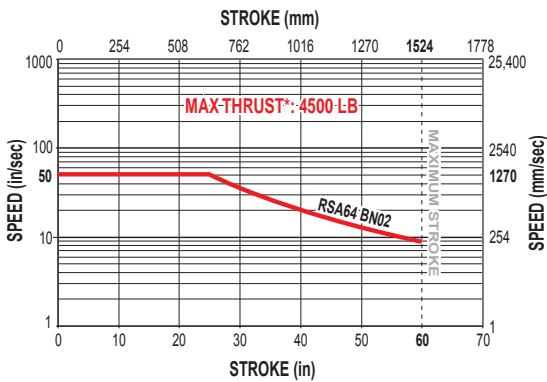

LIFE CALCULATION: 1.5" 2TPI ENGLISH BALL SCREW

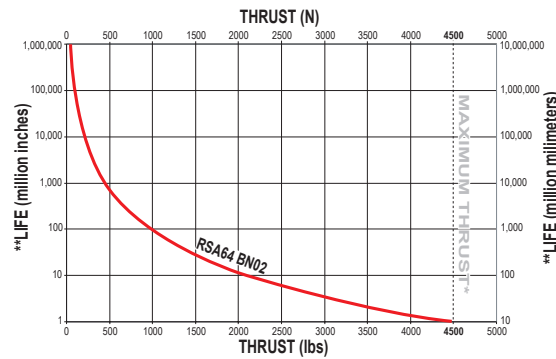

CRITICAL SPEED WITH 1.5" 4TPI ENGLISH BALL SCREW

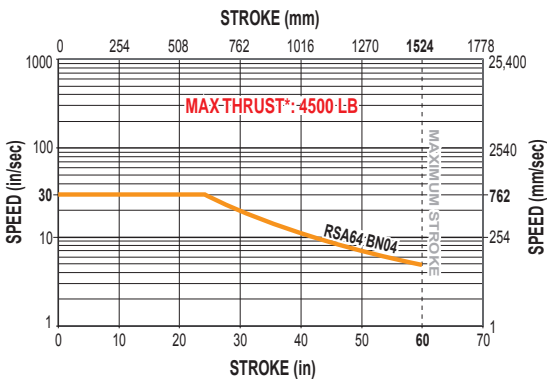

LIFE CALCULATION: 1.5" 4TPI ENGLISH BALL SCREW

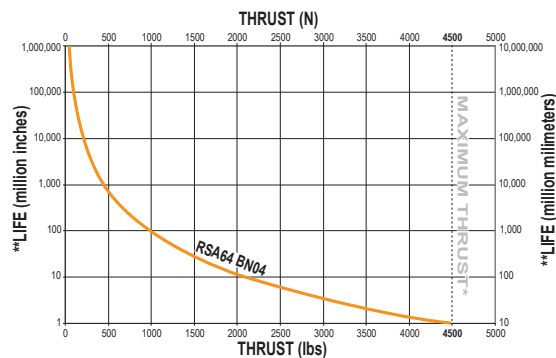

BN = Ball Nut



* Maximum thrust reflects 90% reliability for 1 million linear inches of travel.

**Life indicates theoretical maximum life of screw only, under ideal conditions and does not indicate expected life of actuator.

Axi-dyne® RSA/RSM64 Series

DIMENSIONS

RSA/RSM64 IN-LINE (LMI) BASE MODEL OPTIONS AND SWITCH MOUNTING

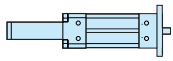

ROD SCREW

RSA/RSM64 Series

- In-line base model and switch mounting

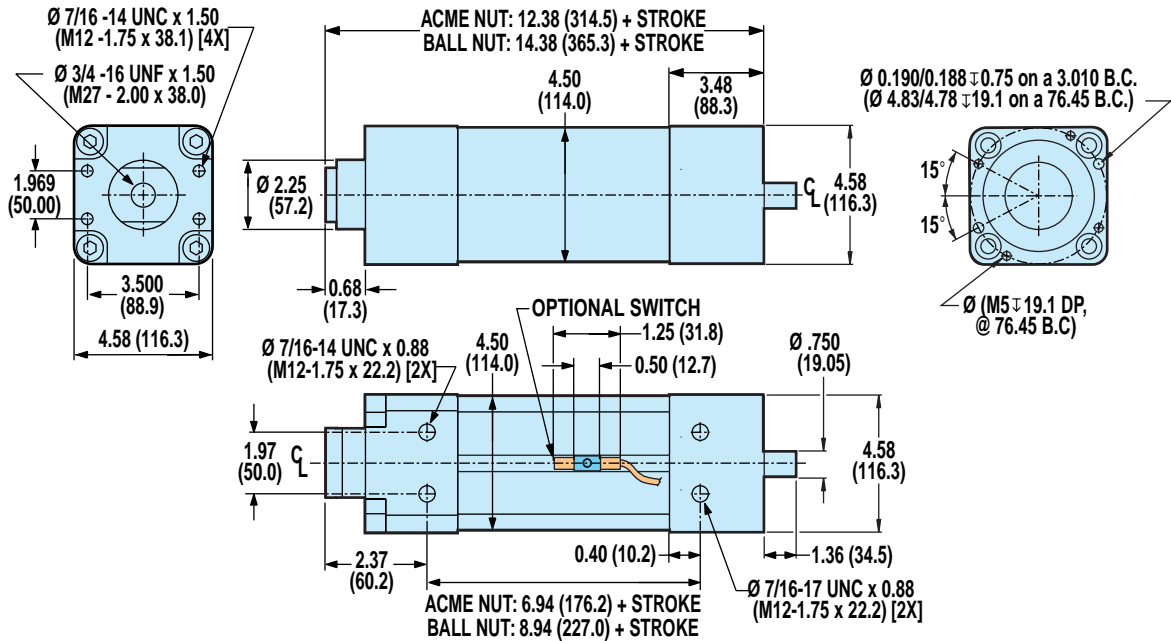

OPTIONAL Trunnion Mount: TRN

⚠ TRUNNION MOUNTS ARE NOT FIELD RETROFITTABLE AND MUST BE CONFIGURED AS PART OF THE BASE ACTUATOR. CONTACT THE FACTORY FOR ADDITIONAL INFORMATION.

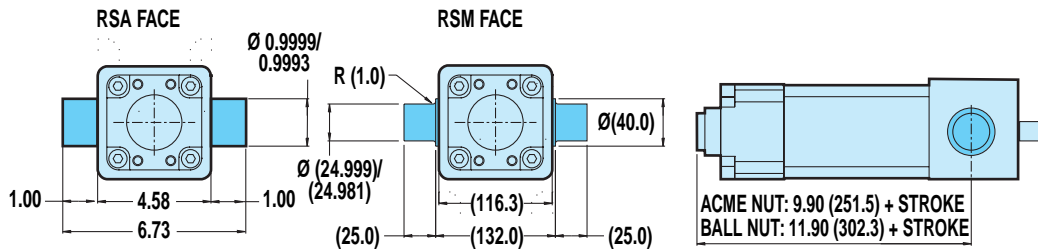

OPTIONAL SWITCH MOUNTING ¹²

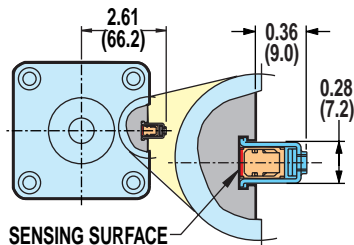

- ⚠ CAUTION: DO NOT OVERTIGHTEN SWITCH HARDWARE WHEN INSTALLING**
- 2** NOTE: The scored face of the switch indicates the sensing surface and must face toward the magnet

Unless otherwise noted, all dimensions shown are in inches (Dimensions in parenthesis are in millimeters)

Axi dyne® RSA/RSM64 Series

DIMENSIONS

RSA/RSM64 REVERSE PARALLEL (RP) BASE MODEL OPTIONS AND SWITCH MOUNTING

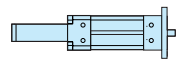
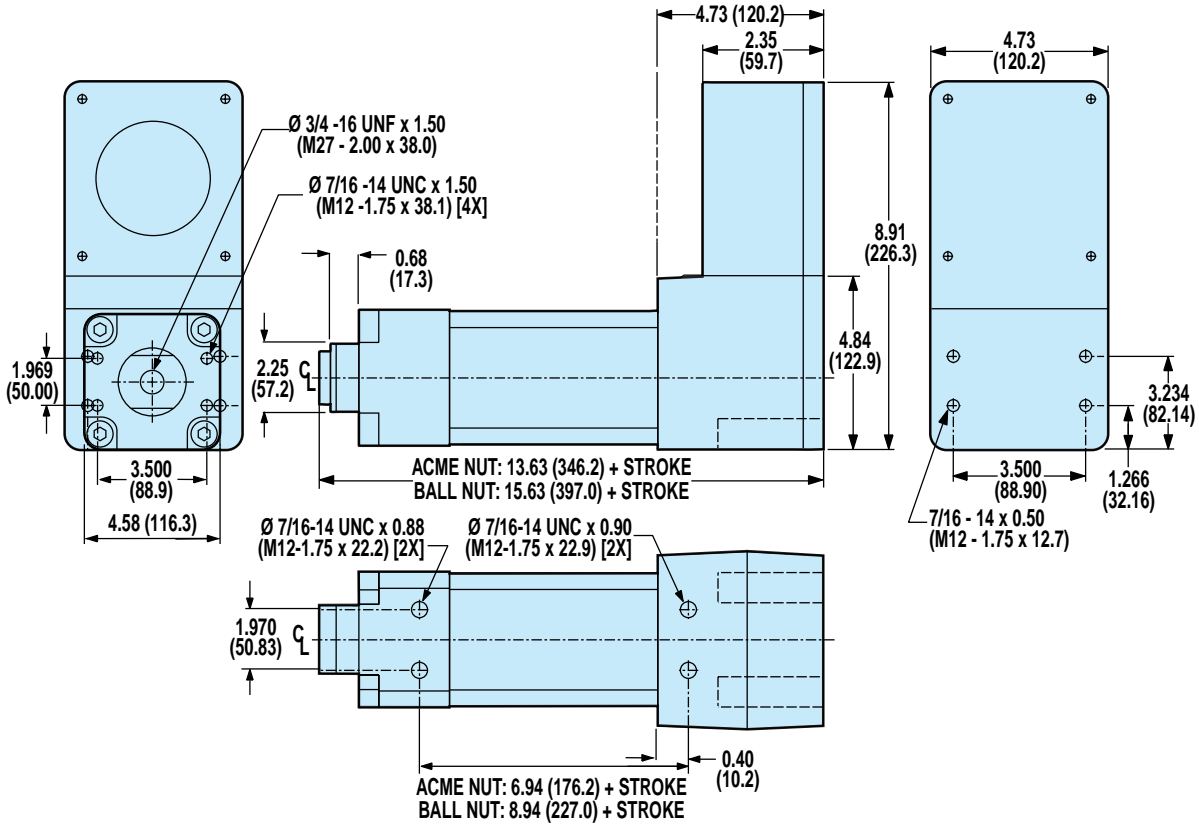

ROD SCREW

RSA/RSM64 Series

- Reverse parallel base model and switch mounting

OPTIONAL Trunnion Mount: TRN

⚠ TRUNNION MOUNTS ARE NOT FIELD RETROFITTABLE AND MUST BE CONFIGURED AS PART OF THE BASE ACTUATOR. CONTACT THE FACTORY FOR ADDITIONAL INFORMATION.

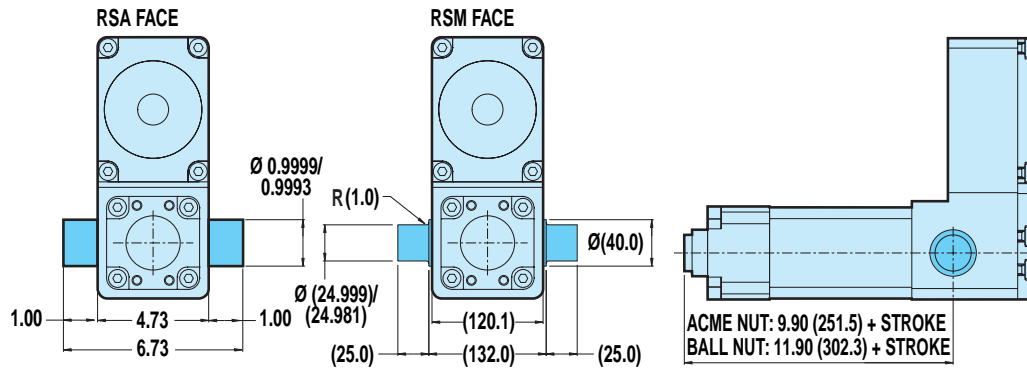

OPTIONAL SWITCH MOUNTING ⚠Ⓜ

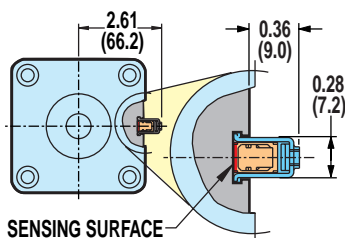

- ⚠ **CAUTION: DO NOT OVERTIGHTEN SWITCH HARDWARE WHEN INSTALLING**
- Ⓜ **NOTE: The scored face of the switch indicates the sensing surface and must face toward the magnet**

Axi-dyne® RSA/RSM64 Series

DIMENSIONS

RSA/RSM64 RETROFITTABLE ROD END OPTIONS

FOR IN-LINE (LMI) OR REVERSE PARALLEL (RP) MODELS

OPTIONAL Spherical Rod End: SRE

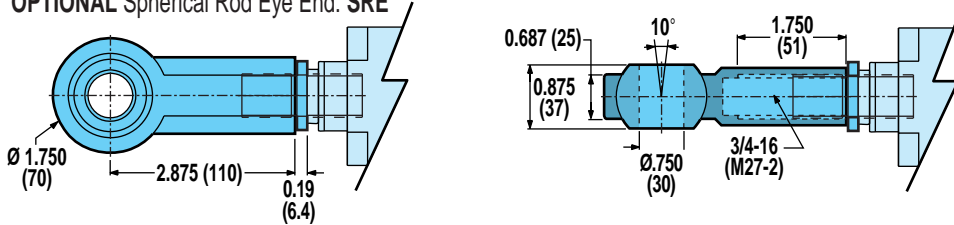

OPTIONAL Alignment Coupler Rod End: ALC

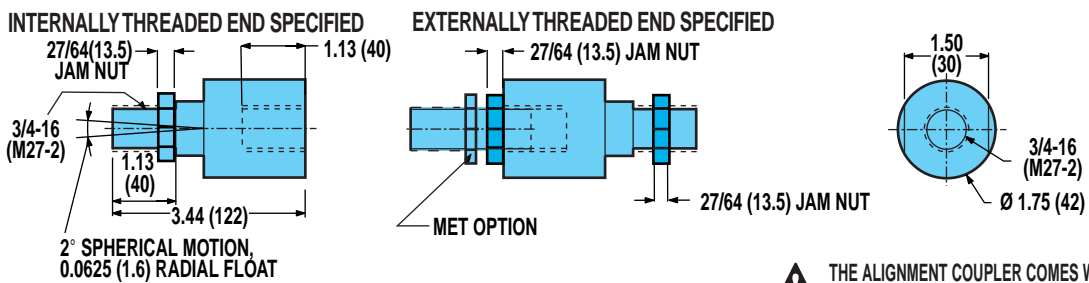

⚠ THE ALIGNMENT COUPLER COMES WITH AN INTERNAL THREAD. IF AN EXTERNAL THREAD IS PREFERRED, THE ADDITION OF THE "MET" OPTION IS REQUIRED.

OPTIONAL External Threaded Rod End: MET

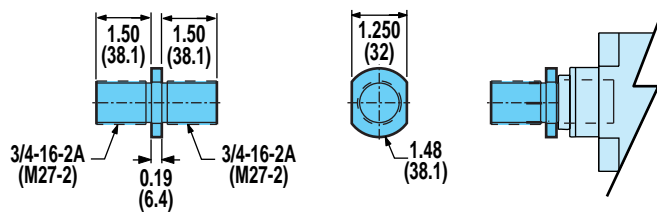

OPTIONAL Clevis Rod End: CLV

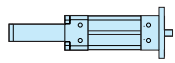
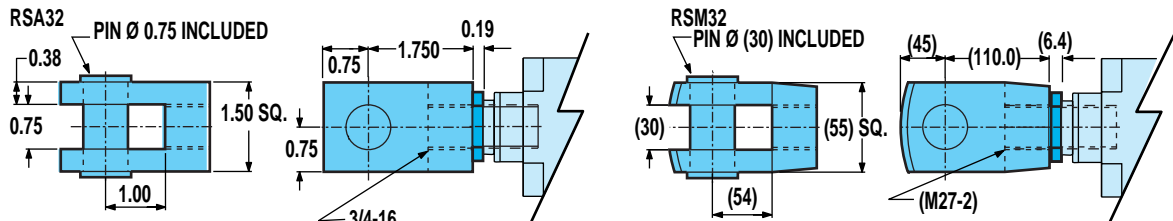

ROD SCREW

RSA/RSM64 Series

- Retrofittable rod end options

Axi dyne® RSA/RSM64 Series

DIMENSIONS

RSA/RSM64 RETROFITTABLE MOUNTING OPTIONS

FOR REVERSE PARALLEL (RP) MODELS ONLY

OPTIONAL Clevis Mount: PCD

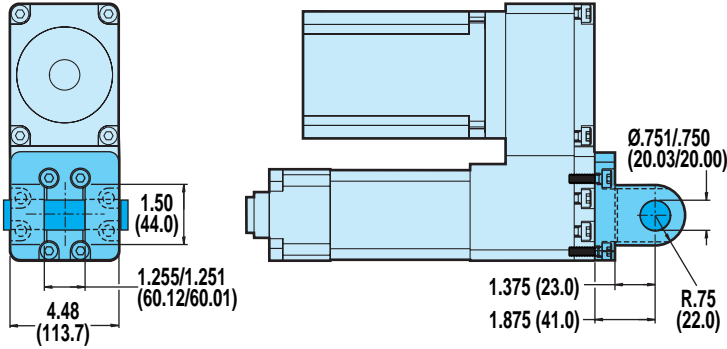

OPTIONAL Eye Mount: PCS

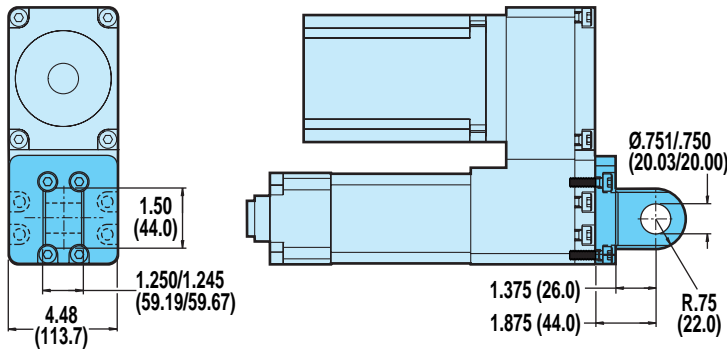

OPTIONAL Foot Mount: FM2

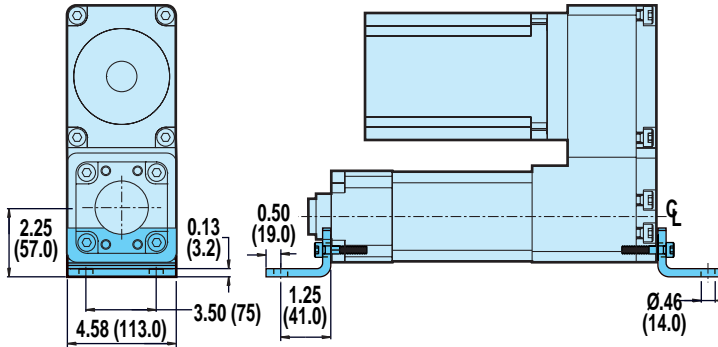

OPTIONAL Back Flange: BFG

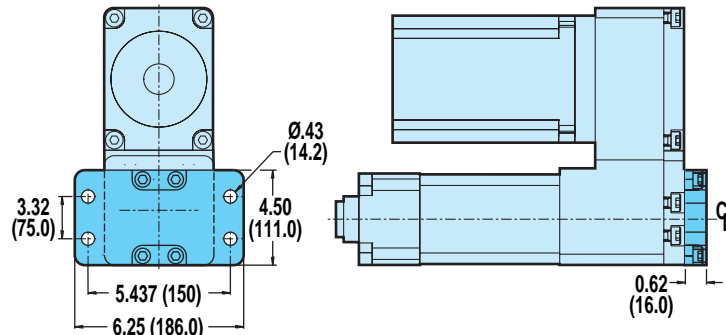

FOR IN-LINE (LMI) OR REVERSE PARALLEL (RP) MODELS

OPTIONAL Mounting Plate: MP2

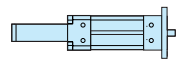
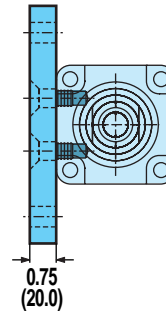

ROD SCREW

RSA/RSM64 Series

- Retrofittable mounting options

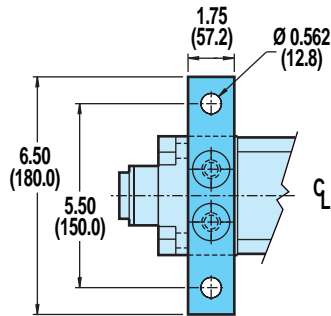

OPTIONAL Front Flange Mount: FFG

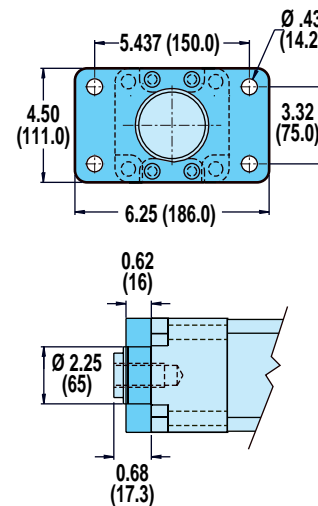

Axi dyne® RSA/RSM64 Series

DIMENSIONS

RSA/RSM64: IN-LINE MOUNTING MOTORS AND GEARHEADS

FRAME	MOTOR	GEARHEAD	A		B		C	
			in	(mm)	in	(mm)	in	(mm)
34	ALL	NO	3.05	(77.5)	2.880	(73.15)	3.875	(98.4)
34	ALL	YES	3.83	(97.3)	2.880	(73.15)	3.875	(98.4)
40	MRB	NO	4.23	(107.4)	2.505	(63.63)	3.25	(82.55)
56	MRV	NO	4.48	(113.8)	4.505	(114.43)	5.875	(149.23)

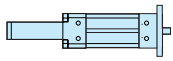

ROD SCREW

RSA/RSM64 Series

- In-line mounting motors and gearheads

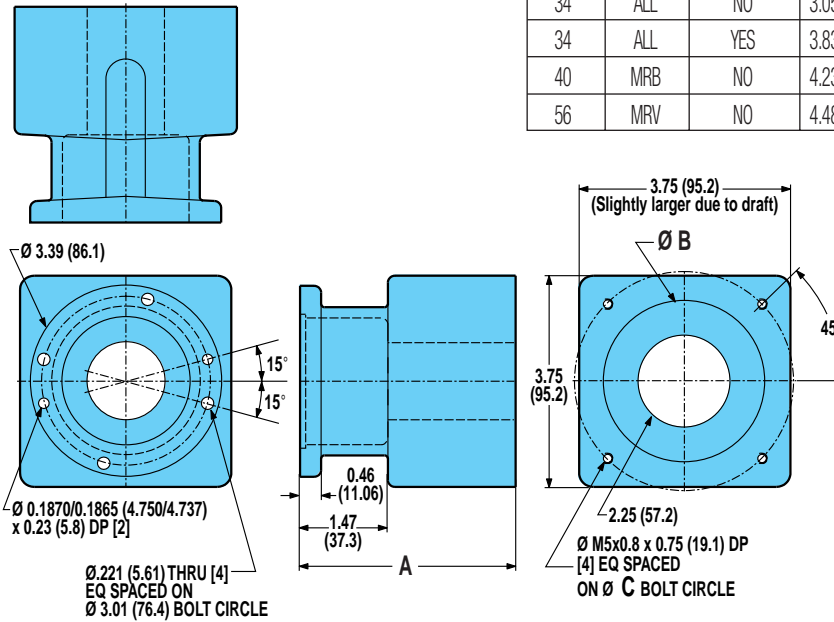

For a complete part listing of screw-drive motor and gearhead mounting kits referencing actuator/motor/coupler compatibilities, refer to document 3600-4631 available on the Literature/Part Sheet/Axidyne section of our web site at: www.tolomatic.com.
For gearhead specifications and dimensions, see page F-10.

RSA/RSM64: REVERSE PARALLEL MOTOR MOUNTING

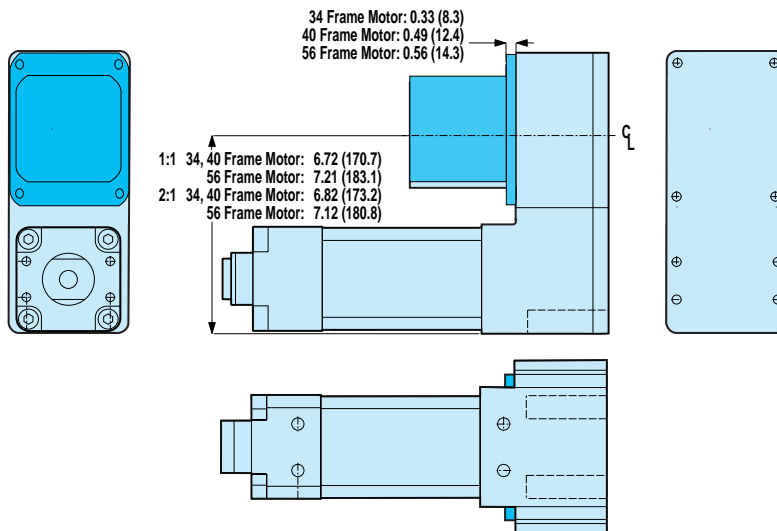

SPECIFICATIONS

MOTOR	REDUCTION INERTIA AT MOTOR SHAFT				
	1:1		2:1		
	lb-in ²	kg-m ² x 10 ⁻⁴	lb-in ²	kg-m ² x 10 ⁻⁴	
BRUSHLESS	MRV31, 32, 33	0.816	238.724	2.428	710.329
	MRV51	0.826	241.692	2.516	735.913
STEPPER	MRS341, 343, 343	0.809	236.551	2.421	708.156
BRUSHED	MRB31, 32, 33	0.816	238.724	2.428	710.329
	MRB42	0.904	264.309	2.516	735.913

REDUCTION EFFICIENCY: 0.95

Axi dyne® RSA/RSM Series

ORDERING

BASE MODEL SPECIFICATIONS

RSA 50 BN02 SK35 RP1TRN

OPTIONS SPECIFICATIONS

XR6 BFG ALCMET KT2

MODEL TYPE

RSA RSA Series English Rod Screw
RSM RSM Series Metric Rod Screw

BODY SIZE

12	32
16	50
24	64

NUT/SCREW CONFIGURATION

SOLID NUT / PITCH (TPI) RSA AND RSM SERIES

SN01	12, 16, 32
SN02	12, 16, 24, 32
SN04	24, 50, 64
SN05	12, 16
SN08	24

BRONZE NUT / PITCH (TPI) RSA AND RSM SERIES

BZ10	12, 16, 24, 32, 50, 64
------	------------------------

BALL NUT / PITCH (TPI) RSA AND RSM SERIES

BN01	50
BN02	32, 50, 64
BN04	50, 64
BN05	24, 32
BN08	12, 16
BN53	64

STROKE LENGTH

SK_ Stroke, then enter desired stroke length in decimal inches

MODEL	MAX STROKE (in)
12 Series	12
16 Series	18
24 Series	24
32 Series	36
50 Series	48
64 Series	60

BASE MODEL

LMI In-line motor mounting base model
RP1 1:1 Reverse parallel mount
RP2 2:1 Reverse parallel mount*
** Not available on 12 or 16 Series.*

BASE MODEL MOUNTING OPTIONS

TRN Add Trunnion Mount (MT2)**
*** Not available on In-line (LMI) 12 or 16 Series.
Trunnion mounts must be built as part of the base actuator and are non-retrofitable.*

ROD EXTENSION OPTION

XR_ Rod Extension* (in inches)
** Selecting this option may exceed the actuators bearing load capabilities. It is recommended for vertical application only.*

ACTUATOR MOUNTING OPTIONS

FM2 Foot Mount (MS1)*
FFG Front Flange Mount (MF2)
PCD Clevis Mount (MP2)*
MP2 Mounting Plate (MS2)
BFG Back Flange Mount (MF2)*
PCS Eye Mount (MP4)*
** Available on Reverse Parallel (RP) base models only.*

ROD END OPTIONS

Internally threaded rod end is standard
MET External Threaded Rod End
CLV Clevis Rod End
SRE Spherical Rod End
ALC Alignment Coupler Rod End*
** If alignment coupler is selected, the external rod end must also be added.*

SWITCHES

RM_ Reed Switch (Form A) with 5-meter lead/QD, and quantity desired
RT_ Reed Switch (Form A) with 5-meter lead, and quantity desired
BM_ Reed Switch (Form C) with 5-meter lead/QD, and quantity desired
BT_ Reed Switch (Form C) with 5-meter lead, and quantity desired
KM_ Hall-effect Sinking Switch with 5-meter lead/QD, and quantity desired
KT_ Hall-effect Sinking Switch with 5-meter lead, and quantity desired
TM_ Hall-effect Sourcing Switch with 5-meter lead/QD, and quantity desired
TT_ Hall-effect Sourcing Switch with 5-meter lead, and quantity desired
CM_ TRIAC Switch with 5-meter lead/QD, and quantity desired
CT_ TRIAC Switch with 5-meter lead, and quantity desired

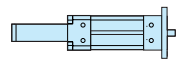

ROD SCREW

RSA/RSM64 Series

- Ordering

TO ORDER MOTORS/CONTROLS/INTERFACES

BRUSHLESS SERVO (SEE PAGE F-33)

MICROSTEPPING (SEE PAGE G-23)

BRUSHED DC (SEE PAGE H-26)



Not all codes listed are compatible with all options.

Use the Tol-O-Motion™ Sizing Software to determine available options and accessories based on your application requirements.

Axi dyne® Rod Screw Actuators

ORDERING

FIELD RETROFIT MOUNTING KITS

Item	12 Series		16 Series		24 Series		32 Series		50 Series		64 Series	
	RSA Kit#	RSM Kit#	RSA Kit#	RSM Kit#	RSA Kit#	RSM Kit#	RSA Kit#	RSM Kit#	RSA Kit#	RSM Kit#	RSA Kit#	RSM Kit#
Front Flange Mount	1107-9013	2107-9013	1112-9013	2112-9013	1124-9022	2124-9032	1132-9022	2132-9042	1150-9022	2150-9042	1164-9022	2164-9022
Foot Mount	1107-9010	2107-9009	1112-9010	2112-9010	1124-9020	2124-9030	1132-9020	2132-9040	1150-9020	2150-9040	1164-9020	2164-9020
Mounting Plate	1107-9015	2107-9015	1112-9014	2112-9014	1124-9023	2124-9033	1132-9023	2132-9043	1150-9023	2150-9043	1164-9023	2164-9023
Back Flange Mount	1107-9014	2107-9014	1112-9013	2112-9025	1124-9022	2124-9032	1132-9022	2132-9042	1150-9022	2150-9042	1164-9022	2164-9022
Eye Mount	1107-9016	2107-9016	1107-9016	2107-9016	1124-9024	2124-9034	1132-9024	2132-9044	1150-9024	2150-9044	1164-9024	2164-9024
Clevis Mount	1107-9017	2107-9017	1107-9017	2107-9017	1124-9025	2124-9035	1132-9025	2132-9045	1150-9025	2150-9045	1164-9025	2164-9025

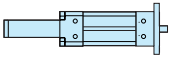

ROD SCREW

FIELD RETROFIT ROD END KITS

RSA/RSM Series

- Ordering

Item	12 Series		16 Series		24 Series		32 Series		50 Series		64 Series	
	RSA Kit#	RSM Kit#	RSA Kit#	RSM Kit#	RSA Kit#	RSM Kit#	RSA Kit#	RSM Kit#	RSA Kit#	RSM Kit#	RSA Kit#	RSM Kit#
External Threaded	1107-1073	2107-1073	1112-1058	2112-1058	1124-1057	2124-1067	1124-1057	2132-1057	1150-1057	2150-1057	1150-1057	2164-1057
Spherical Rod Eye	1107-9020	2107-9020	1112-9019	2112-9019	1124-9028	2124-9038	1124-9028	2132-9048	1150-9028	2150-9048	1150-9028	2164-9028
Clevis End	1107-9021	2107-9021	1112-9020	2112-9020	1124-9029	2124-9039	1124-9029	2132-9049	1150-9029	2150-9049	1150-9029	2164-9029
Alignment Coupler	1107-1076	NA	1112-1065	NA	1124-1060	2124-1070	1124-1060	2132-1060	1150-1060	2150-1060	1150-1060	2164-1060



When interfacing with the threaded end of the Alignment Coupler, an External Threaded Rod End kit is also required.



GSA/GSM GUIDED SCREW ACTUATORS

The following pages contain detailed information about Tol-O-Matic guided-screw rod type actuators. Visit www.tolomatic.com for the latest updates, Tol-O-Motion Sizing Software, CAD files and software support downloads.



GUIDED SCREW

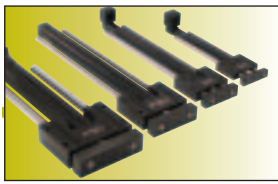

Axi
dyne[®]

Guided Screw Actuators

OVERVIEW

APPLICATION BENEFITS

- Cost-effective choice for short stroke, high thrust applications where external guidance is required
- Good resistance to side loading
- Flexible mounting for pivotal applications
- Wide tooling plate for end effector mounting

BEARING SYSTEM



The GSA/GSM Series design combines a rod screw actuator with a mounting block, guide rods and bearings. Bearings are available in linear ball or composite and guide rods are internally lubricated for increased bearing life.



GUIDED SCREW

GSA/GSM Series

- Application benefits
- Bearing system
- Motor actuator factors
- Standard mounting
- Gearhead reduction
- Motor mounting

MOTOR/ACTUATOR FACTORS

- Actuator's operating temperature range (40-130° F, 4-54° C) should take into consideration heat generated by the motor and drive, linear velocity and work cycle time.
- For large frame motors or small actuators, cantilevered motors need to be supported, if subjected to continuous rapid reversing duty and/or under dynamic conditions.
- Guided screw actuators are designed to push loads that are not separately guided and supported and may be used for applications that require substantial side loading. Reference the performance charts on D-13, 20, 26 and 32 for the appropriate actuator series side loading capacities.

STANDARD MOUNTING



Pre-tapped holes are provided on the actuator mounting block on both the top and side. Mounting surfaces are flat and parallel to plus or minus .002" (0.05 mm).

GEARHEAD REDUCTION



Gearheads are available for applications requiring reduction for inertia matching or higher torque at lower speeds. High efficiency, single stage, true planetary gearheads are available for the GSA/GSM24 and 32 series in 5.5:1 and 10:1 ratios for reduction solutions with most Tol-O-Matic NEMA 23- and 34-frame motors. For gearhead specifications and dimensions, see page F-10.

MOTOR MOUNTING



GSA/GSM guided screw actuators are configured as an in-line base model or a reverse-parallel base model.



In-line Motor Mounting— motor is internally coupled to the actuator shaft.



Reverse-parallel Motor Mounting— These factory assembled configurations allow offset mounting of the motor to either side of, or below the actuator. Available in a 1:1 drive ratio on GSA/GSM12 and 16 series or 1:1 and 2:1 drive ratios for the GSA/GSM24 and 32 series, they offer quiet, zero-backlash coupling of the motor to the actuator screw shaft.

Axi dyne® Guided Screw Actuators

OVERVIEW

AVAILABLE OPTIONS



Stop Collars: Available for both standard and oversize guide rods, stop collars add an extra safety factor for applications requiring heavy loading. Also available in stainless steel.



Stainless steel guide rods and fasteners: Available for both standard and oversize guide rods. Ideal for use in applications where protection from corrosives is required.

 **Option not available with linear ball bearings**

SWITCHES



Switches: Reed, dc Hall-effect and ac TRIAC.
See page I-1.

All Tol-O-Matic products go through months of preliminary testing in our lab to ensure that they live up to our expectations. The simulation below has a series of GSA actuators moving substantial loads, testing for bearing wear and actuator life.



GUIDED SCREW

GSA/GSM Series

- Available options
- Switches



Axi-dyne® Guided Screw Actuators

ACME AND BALL SCREW SPECIFICATIONS

ACME AND BALL SCREW CRITICAL SPEED CAPACITIES

GSA: CRITICAL SPEED WITH ENGLISH ACME SCREW

GSA: CRITICAL SPEED WITH ENGLISH BALL SCREW



GUIDED SCREW

GSA/GSM Series

- Acme and ball screw critical speed

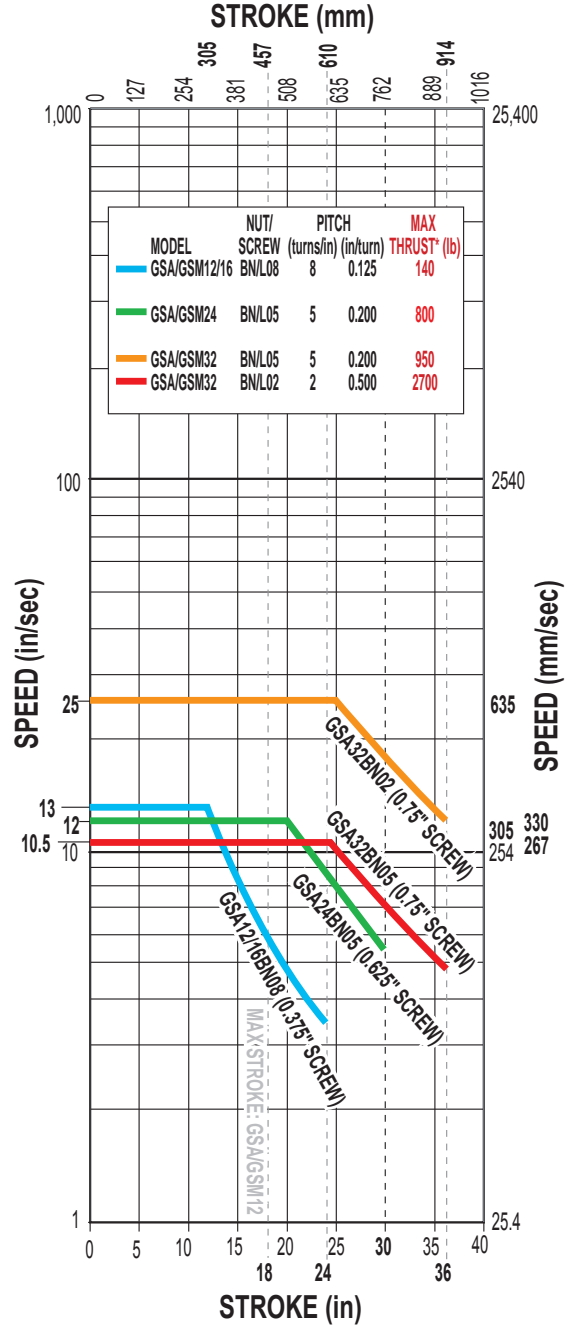
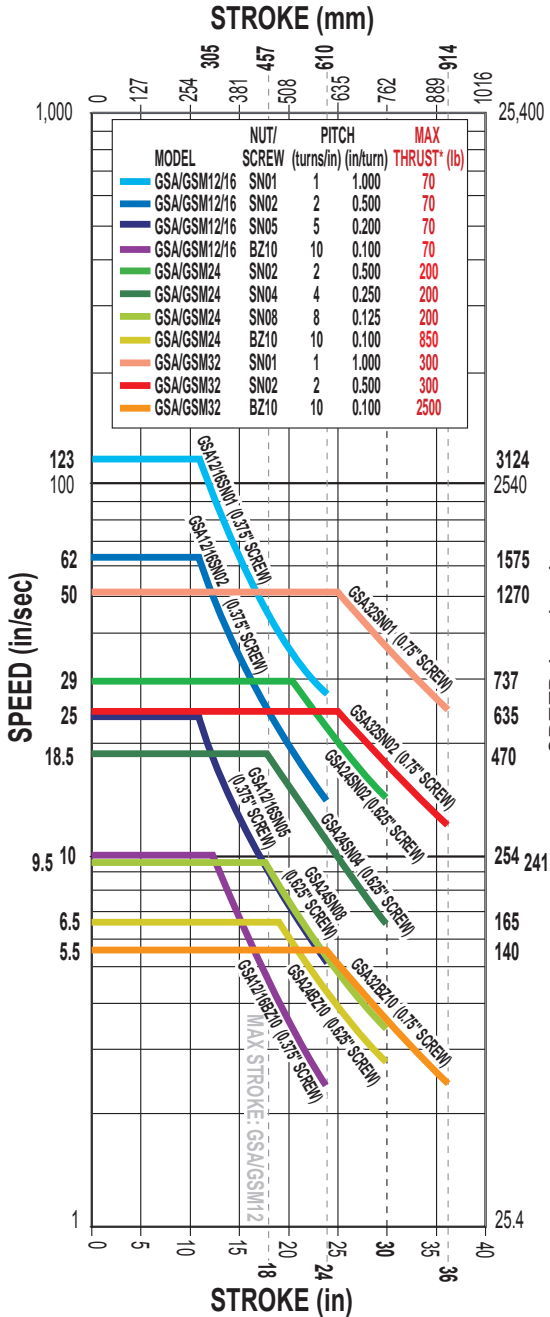

* Acme Screws: Maximum thrust is the maximum continuous dynamic thrust subject to Thrust x Velocity limitation.

Ball Screws: Maximum thrust reflects 90% reliability for 1 million linear inches of travel.

Dotted lines represent maximum stroke for actuator body size.

For Screw PV limits, refer to the individual charts located in the technical section for each actuator body size.

SCREW CODE	DESCRIPTION
SN	Solid Nut
BZ	Bronze Nut
BN	Ball Nut
BNL	Low-backlash Ball Nut

Axi-dyne® Guided Screw Actuators

BALL SCREW SPECIFICATIONS

BALL SCREW LIFE CALCULATIONS

GSA: LIFE CAPACITIES WITH ENGLISH BALL SCREW

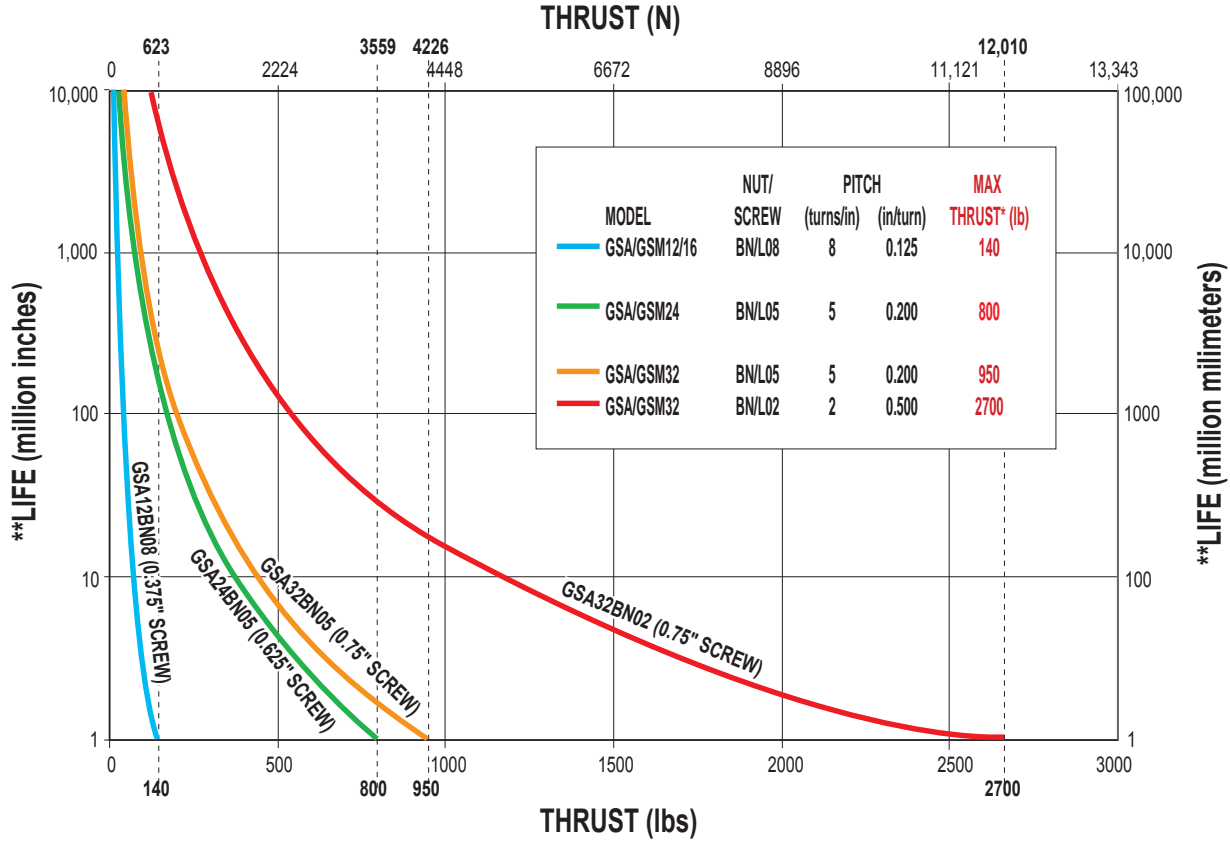

GUIDED SCREW

GSA/GSM Series

- Ball screw life calculations

! * Maximum thrust reflects 90% reliability for 1 million linear inches of travel.

Dotted lines represent maximum thrust for screw selections.

**Life indicates theoretical maximum life of screw only, under ideal conditions and does not indicate expected life of actuator.

Axi dyne® Guided Screw Actuators

OVERALL SERIES SPECIFICATIONS

GSA12/16 SPECIFICATIONS RELATED TO ACTUATOR SIZE / SCREW SELECTION

GSA12 AND GSA16 ACTUATORS WITH ENGLISH LEAD SCREWS														
ACTUATOR SERIES	BEARING TYPE	GUIDE ROD in	SCREW DIA. in	SCREW TYPE	TPI turns/in	LEAD ACCURACY in/ft	BACKLASH in	MAXIMUM THRUST* lb	BASE ACTUATOR INERTIA		INERTIA PER/in OF STROKE lb-in ²	BREAKAWAY TORQUE lb-in	MOVING PARTS WEIGHT	
									In Line lb-in ²	Rev. Parallel lb-in ²			Base lb	Per Inch lb
GSA12	LINEAR	STANDARD Ø0.50	0.38	SN01	1	0.010	0.007	70	0.0324	0.0326	0.0040	2.938	1.21	0.14
				SN02	2	0.006	0.007	70	0.0095	0.0097	0.0014	1.500	1.21	0.14
				SN05	5	0.006	0.007	70	0.0030	0.0032	0.0006	0.563	1.21	0.14
				BZ10	10	0.006	0.008	70	0.0021	0.0023	0.0005	0.438	1.21	0.14
				BN08	8	0.003	0.015	140	0.0023	0.0025	0.0006	0.500	1.29	0.14
				BNL08	8	0.003	0.002	140	0.0023	0.0025	0.0006	0.500	1.29	0.14
	COMPOSITE	STANDARD Ø0.50	0.38	SN01	1	0.010	0.007	70	0.0324	0.0326	0.0040	5.625	1.21	0.14
				SN02	2	0.006	0.007	70	0.0095	0.0097	0.0014	2.813	1.21	0.14
				SN05	5	0.006	0.007	70	0.0030	0.0032	0.0006	1.125	1.21	0.14
				BZ10	10	0.006	0.008	70	0.0021	0.0023	0.0005	0.813	1.21	0.14
				BN08	8	0.003	0.015	140	0.0023	0.0025	0.0006	0.688	1.29	0.14
				BNL08	8	0.003	0.002	140	0.0023	0.0025	0.0006	0.688	1.29	0.14
		OVERSIZED Ø0.63	0.38	SN01	1	0.010	0.007	70	0.0413	0.0415	0.0056	6.125	1.56	0.20
				SN02	2	0.006	0.007	70	0.0117	0.0119	0.0018	3.063	1.56	0.20
				SN05	5	0.006	0.007	70	0.0034	0.0036	0.0007	1.250	1.56	0.20
				BZ10	10	0.006	0.008	70	0.0022	0.0024	0.0006	0.938	1.56	0.20
				BN08	8	0.003	0.015	140	0.0024	0.0026	0.0006	0.750	1.64	0.20
				BNL08	8	0.003	0.002	140	0.0024	0.0026	0.0006	0.750	1.64	0.20
GSA16	LINEAR	STANDARD Ø0.63	0.38	SN01	1	0.010	0.007	70	0.0631	0.0633	0.0058	2.938	2.42	0.21
				SN02	2	0.006	0.007	70	0.0171	0.0173	0.0018	1.500	2.42	0.21
				SN05	5	0.006	0.007	70	0.0043	0.0045	0.0007	0.563	2.42	0.21
				BZ10	10	0.006	0.008	70	0.0024	0.0026	0.0006	0.438	2.42	0.21
				BN08	8	0.003	0.015	140	0.0028	0.0030	0.0006	0.500	2.50	0.21
				BNL08	8	0.003	0.002	140	0.0028	0.0030	0.0006	0.500	2.50	0.21
	COMPOSITE	STANDARD Ø0.63	0.38	SN01	1	0.010	0.007	70	0.0631	0.0633	0.0058	6.125	2.42	0.21
				SN02	2	0.006	0.007	70	0.0171	0.0173	0.0018	3.063	2.42	0.21
				SN05	5	0.006	0.007	70	0.0043	0.0045	0.0007	1.250	2.42	0.21
				BZ10	10	0.006	0.008	70	0.0024	0.0026	0.0006	0.938	2.42	0.21
				BN08	8	0.003	0.015	140	0.0028	0.0030	0.0006	0.688	2.50	0.21
				BNL08	8	0.003	0.002	140	0.0028	0.0030	0.0006	0.688	2.50	0.21
		OVERSIZED Ø0.75	0.38	SN01	1	0.010	0.007	70	0.0763	0.0765	0.0078	6.625	2.94	0.29
				SN02	2	0.006	0.007	70	0.0204	0.0206	0.0023	3.313	2.94	0.29
				SN05	5	0.006	0.007	70	0.0048	0.0050	0.0008	1.313	2.94	0.29
				BZ10	10	0.006	0.008	70	0.0025	0.0027	0.0006	1.000	2.94	0.29
				BN08	8	0.003	0.015	140	0.0030	0.0032	0.0006	0.750	3.02	0.29
				BNL08	8	0.003	0.002	140	0.0030	0.0032	0.0006	0.750	3.02	0.29



GUIDED SCREW

GSA/GSM Series

- Actuator and screw specifications

SCREW CODE	DESCRIPTION
SN	Solid Nut
BZ	Bronze Nut
BN	Ball Nut
BNL	Low-Backlash Ball Nut



Contact the factory for higher accuracy and lower backlash options.

* For Acme screws, maximum thrust is the maximum continuous dynamic thrust subject to Thrust x Velocity limitation.

For ball screws, maximum thrust reflects 90% reliability for 1 million linear inches of travel.

Axi-dyne® Guided Screw Actuators

OVERALL SERIES SPECIFICATIONS

GSA24/32 SPECIFICATIONS RELATED TO ACTUATOR SIZE / SCREW SELECTION

GSA24 AND GSA32 ACTUATORS WITH ENGLISH LEAD SCREWS														
ACTUATOR SERIES	BEARING TYPE	GUIDE ROD Ø	SCREW DIA. in	SCREW TYPE	TPI turns/in	LEAD ACCURACY in/ft	BACKLASH in	MAXIMUM THRUST* lb	BASE ACTUATOR INERTIA		INERTIA PER/in OF STROKE lb-in ²	BREAKAWAY TORQUE lb-in	MOVING PARTS WEIGHT	
									In Line lb-in ²	Rev. Parallel lb-in ²			Base lb	Per Inch lb
GSA24	LINEAR	STANDARD Ø0.75	0.625	SN02	2	0.127	0.18	200	0.0399	0.0404	0.0060	1.875	4.49	0.33
				SN04	4	0.254	0.18	200	0.0260	0.0265	0.0047	1.125	4.49	0.33
				SN08	8	0.254	0.18	200	0.0225	0.0230	0.0043	1.563	4.49	0.33
				BZ10	10	0.152	0.20	850	0.0220	0.0225	0.0043	2.000	4.49	0.33
				BN05	5	0.076	0.38	800	0.0244	0.0249	0.0045	1.563	4.75	0.33
				BNL05	5	0.076	0.02	800	0.0244	0.0249	0.0045	1.563	4.75	0.33
	COMPOSITE	STANDARD Ø0.75	0.625	SN02	2	0.127	0.18	200	0.0497	0.0502	0.0063	3.438	4.49	0.33
				SN04	4	0.254	0.18	200	0.0284	0.0289	0.0047	2.188	4.49	0.33
				SN08	8	0.254	0.18	200	0.0231	0.0236	0.0043	1.563	4.49	0.33
				BZ10	10	0.152	0.20	850	0.0224	0.0229	0.0043	2.000	4.49	0.33
				BN05	5	0.076	0.38	800	0.0261	0.0266	0.0045	1.563	4.75	0.33
				BNL05	5	0.076	0.02	800	0.0261	0.0266	0.0045	1.563	4.75	0.33
		OVERSIZED Ø1.00	0.625	SN02	2	0.127	0.18	200	0.0597	0.0602	0.0076	3.875	6.06	0.53
				SN04	4	0.254	0.18	200	0.0309	0.0314	0.0050	2.813	6.06	0.53
				SN08	8	0.254	0.18	200	0.0237	0.0242	0.0044	1.875	6.06	0.53
				BZ10	10	0.152	0.20	850	0.0228	0.0233	0.0043	2.188	6.06	0.53
				BN05	5	0.076	0.38	800	0.0277	0.0282	0.0047	1.875	6.32	0.53
				BNL05	5	0.076	0.02	800	0.0277	0.0282	0.0047	1.875	6.32	0.53
GSA32	LINEAR	STANDARD Ø1.00	0.75	SN01	1	0.127	0.18	300	0.2903	0.2946	0.0239	4.375	9.03	0.60
				SN02	2	0.127	0.18	300	0.1188	0.1231	0.0125	3.750	9.03	0.60
				BZ10	10	0.152	0.20	2500	0.0639	0.0682	0.0088	2.000	9.03	0.60
				BN02	2	0.102	0.38	2700	0.1218	0.1261	0.0125	3.125	9.51	0.60
				BNL02	2	0.102	0.02	2700	0.1218	0.1261	0.0125	3.125	9.51	0.60
				BN05	5	0.076	0.38	950	0.0712	0.0755	0.0093	1.875	9.51	0.60
				BNL05	5	0.076	0.02	950	0.0712	0.0755	0.0093	1.875	9.51	0.60
				COMPOSITE	STANDARD Ø1.00	0.75	SN01	1	0.127	0.18	300	0.2903	0.2946	0.0239
	SN02	2	0.127				0.18	300	0.1188	0.1231	0.0125	4.375	9.03	0.60
	BZ10	10	0.152				0.20	2500	0.0639	0.0682	0.0088	2.813	9.03	0.60
	BN02	2	0.102				0.38	2700	0.1218	0.1261	0.0125	3.438	9.51	0.60
	BNL02	2	0.102				0.02	2700	0.1218	0.1261	0.0125	3.438	9.51	0.60
	BN05	5	0.076				0.38	950	0.0712	0.0755	0.0093	2.188	9.51	0.60
	BNL05	5	0.076		0.02	950	0.0712	0.0755	0.0093	2.188	9.51	0.60		
	OVERSIZED Ø1.25	0.75	SN01		1	0.127	0.18	300	0.3504	0.3547	0.0305	10.000	11.40	0.86
			SN02		2	0.127	0.18	300	0.1338	0.1381	0.0141	5.625	11.40	0.86
			BZ10		10	0.152	0.20	2500	0.0645	0.0688	0.0089	3.438	11.40	0.86
			BN02	2	0.102	0.38	2700	0.1368	0.1411	0.0141	4.063	11.88	0.86	
BNL02	2	0.102	0.02	2700	0.1368	0.1411	0.0141	4.063	11.88	0.86				
BN05	5	0.076	0.38	950	0.0736	0.0779	0.0096	2.500	11.88	0.86				
BNL05	5	0.076	0.02	950	0.0736	0.0779	0.0096	2.500	11.88	0.86				



GUIDED SCREW

GSA/GSM Series

- Actuator and screw specifications

SCREW CODE	DESCRIPTION
SN	Solid Nut
BZ	Bronze Nut
BN	Ball Nut
BNL	Low-Backlash Ball Nut



Contact the factory for higher accuracy and lower backlash options.

* For Acme screws, maximum thrust is the maximum continuous dynamic thrust subject to Thrust x Velocity limitation.

For ball screws, maximum thrust reflects 90% reliability for 1 million linear inches of travel.

Axi-dyne® Guided Screw Actuators

OVERALL SERIES SPECIFICATIONS

GSM12/16 SPECIFICATIONS RELATED TO ACTUATOR SIZE / SCREW SELECTION

GSM12 AND GSM METRIC ACTUATORS* WITH ENGLISH LEAD SCREWS														
ACTUATOR SERIES	BEARING TYPE	GUIDE ROD in	SCREW DIA. in	SCREW TYPE	TPI turns/in	LEAD ACCURACY mm/300	BACKLASH mm	MAXIMUM THRUST** N	BASE ACTUATOR INERTIA		INERTIA PER/in OF STROKE kg-m ² x 10 ⁴	BREAKAWAY TORQUE N-m	MOVING PARTS WEIGHT	
									In Line kg-m ² x 10 ⁴	Rev. Parallel kg-m ² x 10 ⁴			Base N	Per Inch N
GSM12	LINEAR	STANDARD Ø0.50	0.38	SN01	1	0.254	0.18	311	9.492	9.550	1.184	0.332	5.38	0.62
				SN02	2	0.152	0.18	311	2.768	2.826	0.406	0.169	5.38	0.62
				SN05	5	0.152	0.18	311	0.885	0.944	0.188	0.064	5.38	0.62
				BZ10	10	0.152	0.20	311	0.616	0.675	0.157	0.049	5.38	0.62
				BN08	8	0.076	0.38	623	0.676	0.734	0.163	0.056	5.74	0.62
				BNL08	8	0.076	0.05	623	0.676	0.734	0.163	0.056	5.74	0.62
	COMPOSITE	STANDARD Ø0.50	0.38	SN01	1	0.254	0.18	311	9.492	9.550	1.184	0.636	5.38	0.62
				SN02	2	0.152	0.18	311	2.798	2.826	0.406	0.318	5.38	0.62
				SN05	5	0.152	0.18	311	0.885	0.944	0.188	0.127	5.38	0.62
				BZ10	10	0.152	0.20	311	0.616	0.675	0.157	0.092	5.38	0.62
				BN08	8	0.076	0.38	623	0.676	0.734	0.163	0.078	5.74	0.62
				BNL08	8	0.076	0.05	623	0.676	0.734	0.163	0.078	5.74	0.62
		OVERSIZED Ø0.63	0.38	SN01	1	0.254	0.18	311	12.085	12.143	1.628	0.692	6.94	0.89
				SN02	2	0.152	0.18	311	3.416	3.475	0.517	0.346	6.94	0.89
				SN05	5	0.152	0.18	311	0.989	1.047	0.206	0.141	6.94	0.89
				BZ10	10	0.152	0.20	311	0.642	0.701	0.161	0.106	6.94	0.89
				BN08	8	0.076	0.38	623	0.716	0.775	0.169	0.085	7.30	0.89
				BNL08	8	0.076	0.05	623	0.716	0.775	0.169	0.085	7.30	0.89
GSM16	LINEAR	STANDARD Ø0.63	0.38	SN01	1	0.254	0.18	311	18.457	18.515	1.702	0.332	10.77	0.93
				SN02	2	0.152	0.18	311	5.009	5.068	0.535	0.169	10.77	0.93
				SN05	5	0.152	0.18	311	1.245	1.302	0.209	0.064	10.77	0.93
				BZ10	10	0.152	0.20	311	0.706	0.764	0.162	0.049	10.77	0.93
				BN08	8	0.076	0.38	623	0.816	0.874	0.171	0.056	11.12	0.93
				BNL08	8	0.076	0.05	623	0.816	0.874	0.171	0.056	11.12	0.93
	COMPOSITE	STANDARD Ø0.63	0.38	SN01	1	0.254	0.18	311	18.457	18.515	1.702	0.692	10.77	0.93
				SN02	2	0.152	0.18	311	5.009	5.068	0.535	0.346	10.77	0.93
				SN05	5	0.152	0.18	311	1.244	1.302	0.209	0.141	10.77	0.93
				BZ10	10	0.152	0.20	311	0.706	0.764	0.162	0.106	10.77	0.93
				BN08	8	0.076	0.38	623	0.816	0.874	0.171	0.078	11.12	0.93
				BNL08	8	0.076	0.05	623	0.816	0.874	0.171	0.078	11.12	0.93
		OVERSIZED Ø0.75	0.38	SN01	1	0.254	0.18	311	22.309	22.368	2.295	0.749	13.08	1.29
				SN02	2	0.152	0.18	311	5.972	6.031	0.683	0.374	13.08	1.29
				SN05	5	0.152	0.18	311	1.398	1.456	0.232	0.148	13.08	1.29
				BZ10	10	0.152	0.20	311	0.744	0.803	0.168	0.113	13.08	1.29
				BN08	8	0.076	0.38	623	0.876	0.935	0.180	0.085	13.43	1.29
				BNL08	8	0.076	0.05	623	0.876	0.935	0.180	0.085	13.43	1.29



GUIDED SCREW

GSA/GSM Series

- Actuator and screw specifications

SCREW CODE	DESCRIPTION
SN	Solid Nut
BZ	Bronze Nut
BN	Ball Nut
BNL	Low-Backlash Ball Nut



Contact the factory for higher accuracy and lower backlash options.

* GSM metric actuators use the same leadscrew as the GSA English series. Mounting threaded and dowel pin holes on GSM series are metric.

** For Acme screws, maximum thrust is the maximum continuous dynamic thrust subject to Thrust x Velocity limitation.

For ball screws, maximum thrust reflects 90% reliability for 1 million linear inches of travel.

Axi-dyne® Guided Screw Actuators

OVERALL SERIES SPECIFICATIONS

GSM24/32 SPECIFICATIONS RELATED TO ACTUATOR SIZE / SCREW SELECTION

GSM24 AND GSM32 METRIC ACTUATORS* WITH ENGLISH LEAD SCREWS														
ACTUATOR SERIES	BEARING TYPE	GUIDE ROD in	SCREW DIA. in	SCREW TYPE	TPI turns/in	LEAD ACCURACY mm/300	BACKLASH mm	MAXIMUM THRUST** N	BASE ACTUATOR INERTIA		INERTIA PER/in OF STROKE kg-m² x 10⁴	BREAKAWAY TORQUE N-m	MOVING PARTS WEIGHT	
									In Line kg-m² x 10⁴	Rev. Parallel kg-m² x 10⁴			Base N	Per Inch N
GSM24	LINEAR	STANDARD Ø0.75	0.625	SN02	2	0.127	0.18	890	11.676	11.822	1.764	0.212	19.97	1.47
				SN04	4	0.254	0.18	890	7.592	7.738	1.361	0.177	19.97	1.47
				SN08	8	0.254	0.18	890	6.571	6.717	1.260	0.177	19.97	1.47
				BZ10	10	0.152	0.20	3781	6.448	6.594	1.248	0.226	19.97	1.47
				BN05	5	0.076	0.38	3558	7.125	7.272	1.313	0.177	21.13	1.47
				BNL05	5	0.076	0.02	3558	7.125	7.272	1.313	0.177	21.13	1.47
	COMPOSITE	STANDARD Ø0.75	0.625	SN02	2	0.127	0.18	890	14.547	14.693	1.838	0.388	19.97	1.47
				SN04	4	0.254	0.18	890	8.309	8.456	1.380	0.247	19.97	1.47
				SN08	8	0.254	0.18	890	6.750	6.896	1.265	0.177	19.97	1.47
				BZ10	10	0.152	0.20	3781	6.563	6.709	1.251	0.226	19.97	1.47
				BN05	5	0.076	0.38	3558	7.638	7.784	1.325	0.177	21.13	1.47
				BNL05	5	0.076	0.02	3558	7.638	7.784	1.325	0.177	21.13	1.47
		OVERSIZED Ø1.00	0.625	SN02	2	0.127	0.18	890	17.455	17.601	2.209	0.438	26.96	2.36
				SN04	4	0.254	0.18	890	9.037	9.183	1.472	0.318	26.96	2.36
				SN08	8	0.254	0.18	890	6.932	7.078	1.288	0.212	26.96	2.36
				BZ10	10	0.152	0.20	3781	6.679	6.826	1.266	0.247	26.96	2.36
				BN05	5	0.076	0.38	3558	8.103	8.230	1.384	0.212	28.11	2.36
				BNL05	5	0.076	0.02	3558	8.103	8.230	1.384	0.212	28.11	2.36
GSM32	LINEAR	STANDARD Ø1.00	0.75	SN01	1	0.127	0.18	1334	84.922	86.180	6.987	0.494	40.17	2.67
				SN02	2	0.127	0.18	1334	34.744	36.002	3.653	0.424	40.17	2.67
				BZ10	10	0.152	0.20	11,120	18.687	19.945	2.586	0.226	40.17	2.67
				BN02	2	0.120	0.38	12,010	35.633	36.891	3.653	0.353	42.30	2.67
				BNL02	2	0.120	0.02	12,010	35.633	36.891	3.653	0.353	42.30	2.67
				BN05	5	0.076	0.38	4226	20.836	22.094	2.720	0.212	42.30	2.67
	COMPOSITE	STANDARD Ø1.00	0.75	SN01	1	0.127	0.18	1334	84.922	86.180	6.987	0.982	40.17	2.67
				SN02	2	0.127	0.18	1334	34.744	36.002	3.653	0.494	40.17	2.67
				BZ10	10	0.152	0.20	11,120	18.687	19.945	2.586	0.318	40.17	2.67
				BN02	2	0.120	0.38	12,010	35.633	36.891	3.653	0.388	42.30	2.67
				BNL02	2	0.120	0.02	12,010	35.633	36.891	3.653	0.388	42.30	2.67
				BN05	5	0.076	0.38	4226	20.836	22.094	2.720	0.247	42.30	2.67
		OVERSIZED Ø1.25	0.75	SN01	1	0.127	0.18	1334	102.482	103.740	8.914	1.130	50.71	3.83
				SN02	2	0.127	0.18	1334	39.134	40.392	4.135	0.636	50.71	3.83
				BZ10	10	0.152	0.20	11,120	18.863	20.120	2.606	0.388	50.71	3.83
				BN02	2	0.120	0.38	12,010	40.023	41.281	4.135	0.459	52.85	3.83
				BNL02	2	0.120	0.02	12,010	40.023	41.281	4.135	0.459	52.85	3.83
				BN05	5	0.076	0.38	4226	21.539	22.797	2.797	0.282	52.85	3.83



GUIDED SCREW

GSA/GSM Series

- Actuator and screw specifications

SCREW CODE	DESCRIPTION
SN	Solid Nut
BZ	Bronze Nut
BN	Ball Nut
BNL	Low-Backlash Ball Nut



Contact the factory for higher accuracy and lower backlash options.

GSM metric actuators use the same leadscrew as the GSA English series. Mounting threaded and dowel pin holes on GSM series are metric.

**For Acme screws, maximum thrust is the maximum continuous dynamic thrust subject to Thrust x Velocity limitation.

For ball screws, maximum thrust reflects 90% reliability for 1 million linear inches of travel.

Axi dyne® Guided Screw Actuators

OVERALL SERIES SPECIFICATIONS

GENERAL ACTUATOR SPECIFICATIONS

SPECIFICATIONS	GSA ENGLISH ACTUATORS									
	GSA12				GSA16		GSA24		GSA32	
	17 frame		23 frame							
	GUIDE RODS		GUIDE RODS		GUIDE RODS		GUIDE RODS		GUIDE RODS	
	STANDARD	OVERSIZED	STANDARD	OVERSIZED	STANDARD	OVERSIZED	STANDARD	OVERSIZED	STANDARD	OVERSIZED
Weights										
In-Line base weight (lb)	3.65	4.44	3.68	4.47	7.25	7.54	16.48	17.35	27.34	28.65
Reverse parallel base weight (lb)	3.92	4.72	4.05	4.85	7.59	7.88	17.09	17.96	28.81	30.12
Weight per in of stroke (lb)	0.21	0.27	0.21	0.27	0.30	0.38	0.54	0.74	0.93	1.19
Maximum Stroke (in)	18	18	18	18	24	24	30	30	36	36
Temperature Operating Range* (F)	40 - 130	40 - 130	40 - 130	40 - 130	40 - 130	40 - 130	40 - 130	40 - 130	40 - 130	40 - 130
IP Rating**	66	66	66	66	66	66	66	66	66	66



GUIDED SCREW

GSA/GSM Series

- General actuator specifications

SPECIFICATIONS	GSM METRIC ACTUATORS									
	GSM12				GSM16		GSM24		GSM32	
	17 frame		23 frame							
	GUIDE RODS		GUIDE RODS		GUIDE RODS		GUIDE RODS		GUIDE RODS	
	STANDARD	OVERSIZED	STANDARD	OVERSIZED	STANDARD	OVERSIZED	STANDARD	OVERSIZED	STANDARD	OVERSIZED
Weights										
In-Line base weight (kg)	1.65	2.01	1.67	2.03	3.29	3.42	7.48	7.87	12.40	13.00
Reverse parallel base weight (kg)	1.78	2.14	1.84	2.20	3.44	3.57	7.75	8.15	13.07	13.66
Weight per mm of stroke (kg)	0.004	0.005	0.004	0.005	0.005	0.007	0.010	0.013	0.017	0.021
Maximum Stroke (mm)	457	457	457	457	610	610	762	762	914	914
Temperature Operating Range* (°C)	4 - 54	4 - 54	4 - 54	4 - 54	4 - 54	4 - 54	4 - 54	4 - 54	4 - 54	4 - 54
IP Rating**	66	66	66	66	66	66	66	66	66	66



* Heat generated by the motor and drive should be taken into consideration as well as linear velocity and work cycle time. For applications that require operation outside of the recommended temperature range, contact the factory.

** Protected against ingress of solid particles greater than .039 in (1mm) and splashing water.

LARGE FRAME MOTORS AND SMALLER SIZE ACTUATORS: Cantilevered motors need to be supported, if subjected to continuous rapid reversing duty and/or under dynamic conditions.

SIDE LOADING CONSIDERATIONS: Guided screw actuators are designed to push loads that are not separately guided and supported and may be used for applications that require substantial side loading. Use the performance charts shown for each actuator size to determine its side loading capacities. The charts assume that the GSA is mounted horizontally. Tol-O-Matic recommends that you use the Tol-O-Motion Sizing Software to choose the correct actuator for your application. Contact the factory for questions regarding side loading capabilities or selection.

Axi-dyne® GSA/GSM12 Series

ACME SCREW SPECIFICATIONS

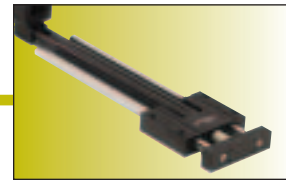

GSA/GSM12 ACME SCREW CRITICAL SPEED AND PV LIMITS

CRITICAL SPEED WITH 0.375" 1TPI ENGLISH ACME SCREW

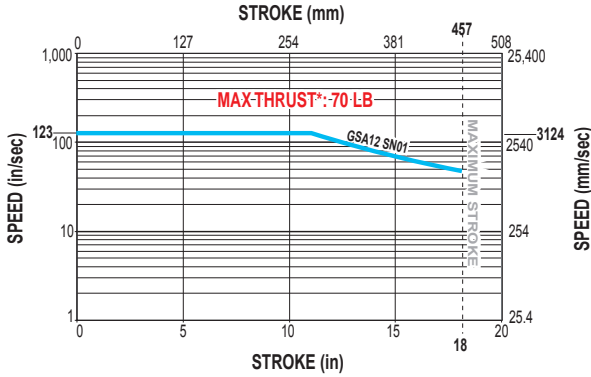

PV LIMITS: 0.375" 1TPI ENGLISH ACME SCREW

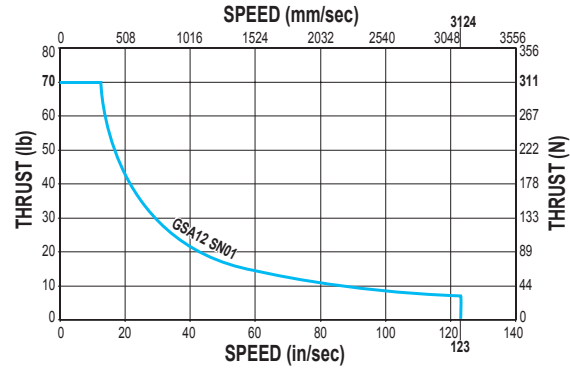

CRITICAL SPEED WITH 0.375" 2TPI ENGLISH ACME SCREW

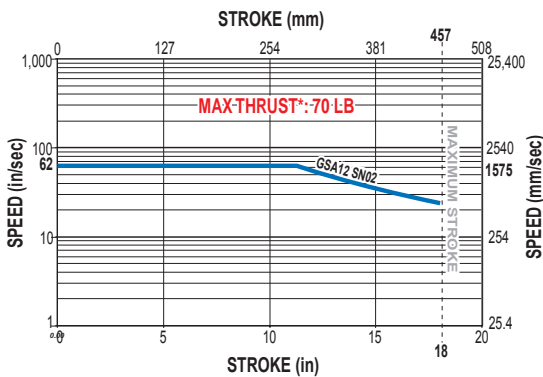

PV LIMITS: 0.375" 2TPI ENGLISH ACME SCREW

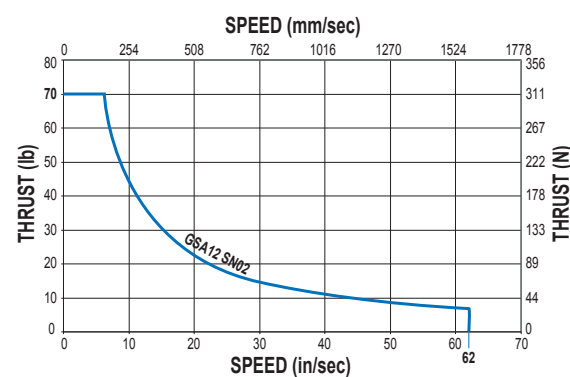

GUIDED SCREW

GSA/GSM12 Series

- Acme screw critical speed and PV limits

CRITICAL SPEED WITH 0.375" 5TPI ENGLISH ACME SCREW

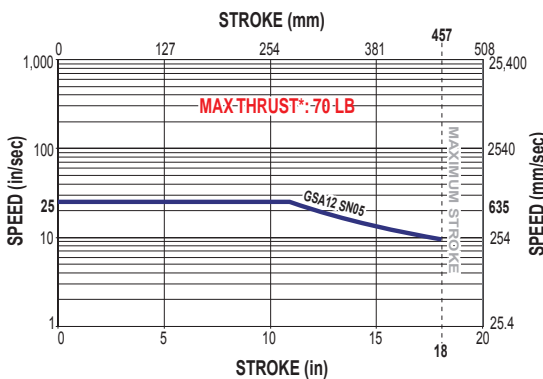

PV LIMITS: 0.375" 5TPI ENGLISH ACME SCREW

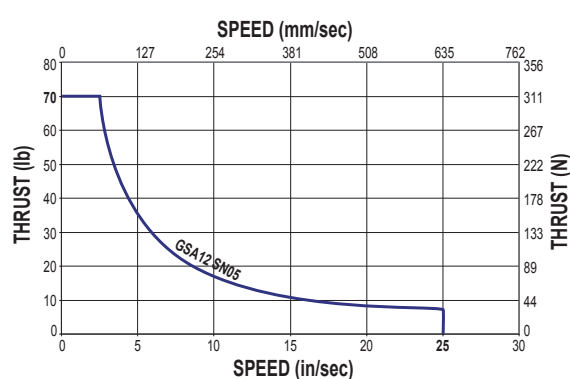

SN = Solid Nut



* Maximum thrust is the maximum continuous dynamic thrust subject to Thrust x Velocity limitation.

PV LIMITS: Any material which carries a sliding load is limited by heat buildup. The factors that affect heat generation rate in an application are the pressure on the nut in pounds per square inch and the surface velocity in feet per minute. The product of these factors provides a measure of the severity of an application.

$$P = \frac{\text{Thrust}}{\text{Max. Thrust Rating}} \times V = \frac{\text{Speed}}{\text{Max. Speed Rating}} \leq 0.1$$

Axi-dyne® GSA/GSM12 Series

ACME AND BALL SCREW SPECIFICATIONS

GSA/GSM12 ACME SCREW CRITICAL SPEED AND PV LIMITS (continued)

CRITICAL SPEED WITH 0.375" 10TPI ENGLISH ACME SCREW

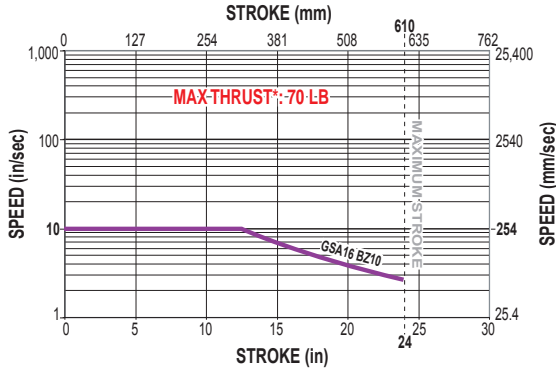

PV LIMITS: 0.375" 10TPI ENGLISH ACME SCREW

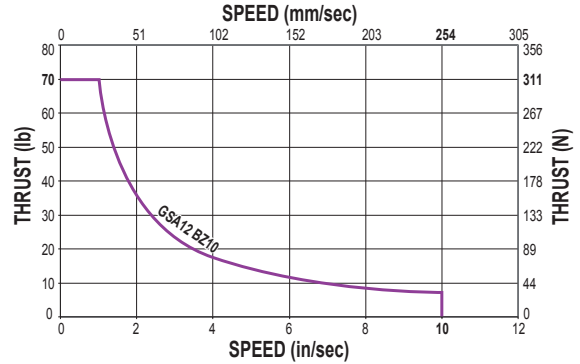

BZ = Bronze Nut



* Maximum thrust is the maximum continuous dynamic thrust subject to Thrust x Velocity limitation.

PV LIMITS: Any material which carries a sliding load is limited by heat buildup. The factors that affect heat generation rate in an application are the pressure on the nut in pounds per square inch and the surface velocity in feet per minute. The product of these factors provides a measure of the severity of an application.

$$P = \frac{\text{Thrust}}{\text{Max. Thrust Rating}} \times V = \frac{\text{Speed}}{\text{Max. Speed Rating}} \leq 0.1$$



GUIDED SCREW

GSA/GSM12 Series

- Acme screw critical speed and PV limits
- Ball screw critical speed and life calculations

GSA/GSM12 BALL SCREW CRITICAL SPEED AND LIFE CALCULATIONS

CRITICAL SPEED WITH 0.375" 8TPI ENGLISH BALL SCREW

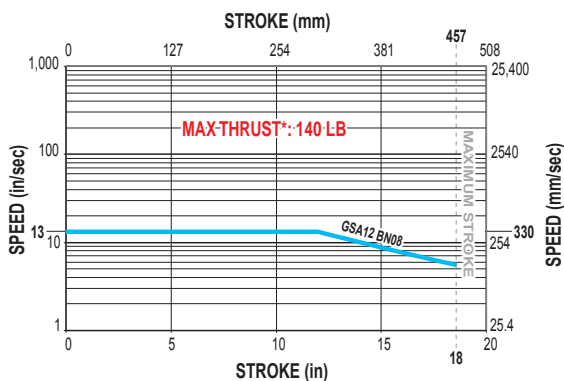

LIFE CALCULATION: 0.375" 8TPI ENGLISH BALL SCREW

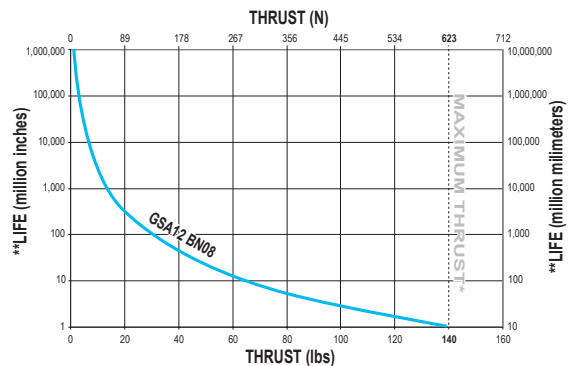

BN = Ball Nut



* Maximum thrust reflects 90% reliability for 1 million linear inches of travel.

**Life indicates theoretical maximum life of screw only, under ideal conditions and does not indicate expected life of actuator.

GSA/GSM12 MAXIMUM LOAD WEIGHT AND GUIDE ROD DEFLECTION

MAXIMUM LOAD WEIGHT vs STROKE LENGTH
LINEAR BALL BEARING, STANDARD GUIDE RODS

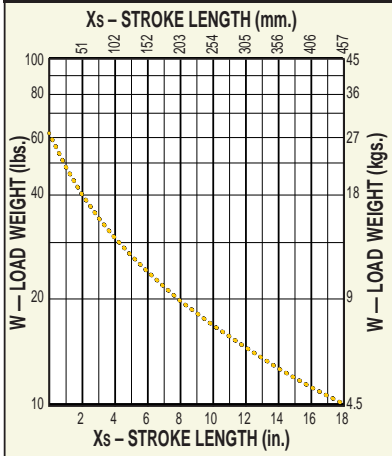

Linear ball bearings are not available with stainless-steel guide rod option.

MAXIMUM LOAD WEIGHT vs STROKE LENGTH
COMPOSITE BEARING, STANDARD GUIDE RODS

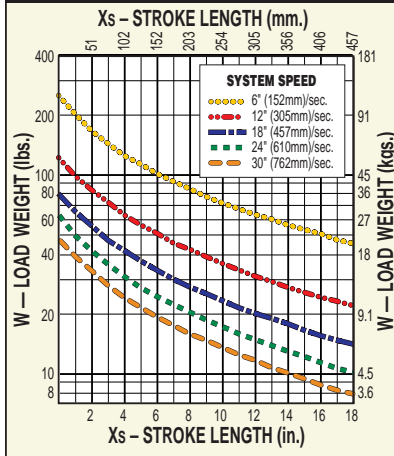

MAXIMUM LOAD WEIGHT vs STROKE LENGTH
COMPOSITE BEARING, OVERSIZE GUIDE RODS

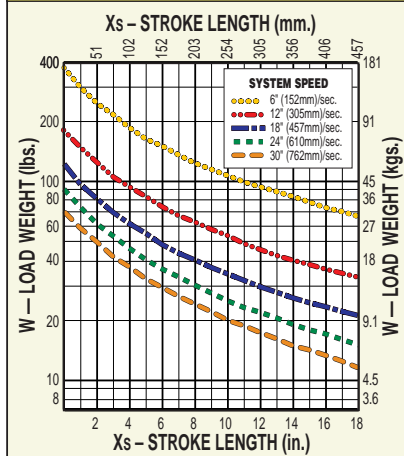

DO NOT EXCEED MAXIMUM LOAD CURVE

Maximum load values are based on 200 million linear inches of travel.

- To obtain most accurate results, stroke length should be adjusted by the distance between the center of mass of the load and tooling plate.

$$X_{adj} = X_s + X_{cm}$$

Then, use X_{adj} instead of X_s on the Maximum Load Weight vs. Stroke Length graph.

- For the off-center loads, calculate adjusted load weight using the following formula:

$$W_{adj} = W (1 + 0.67 Y_{cm})$$

where Y_{cm} is distance between center of mass of off-center load and center of tooling plate.

Then, use W_{adj} instead of W on Maximum Load Weight vs. Stroke Length graph.

- Using your stroke length and load weight, evaluate guide rod deflection. If the intersection point is above the highest curve (.064"), contact Tol-O-Matic for assistance.



- Impact loading is not recommended for GSA/GSM actuators.
- Motor breaks may be required on vertically positioned actuators with plastic (solid) or ball nuts in applications with risk of load backdriving. (Actuators with bronze nuts will not backdrive for loads, thrusts within catalog specifications.)

Contact Tol-O-Matic for assistance.

GUIDE ROD DEFLECTION
STANDARD GUIDE RODS

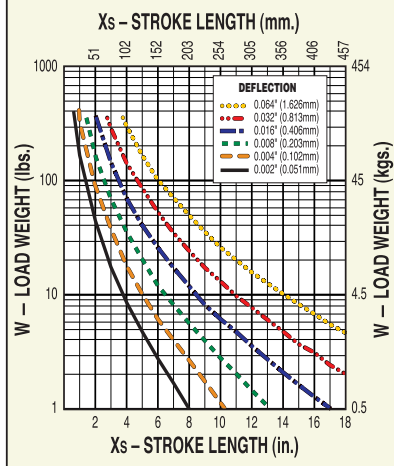

GUIDE ROD DEFLECTION
OVERSIZE GUIDE RODS

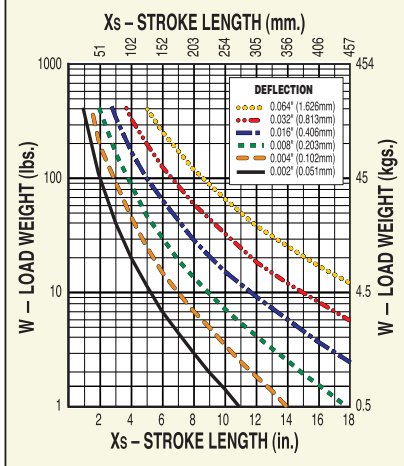

GUIDED SCREW

GSA/GSM12 Series

- Maximum load weight and guide rod deflection

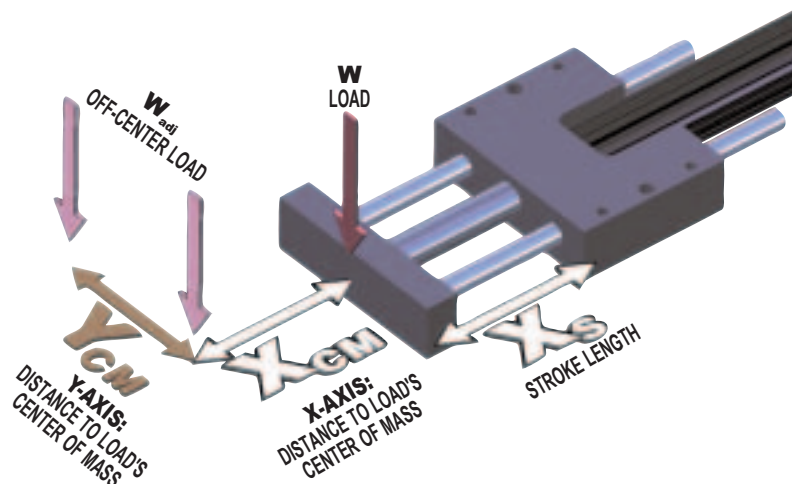

Axi dyne® GSA/GSM12 Series

DIMENSIONS

GSA/GSM12 IN-LINE (LMI) BASE MODEL AND SWITCH MOUNTING



GUIDED SCREW

GSA/GSM12 Series

- In-line base model dimensions

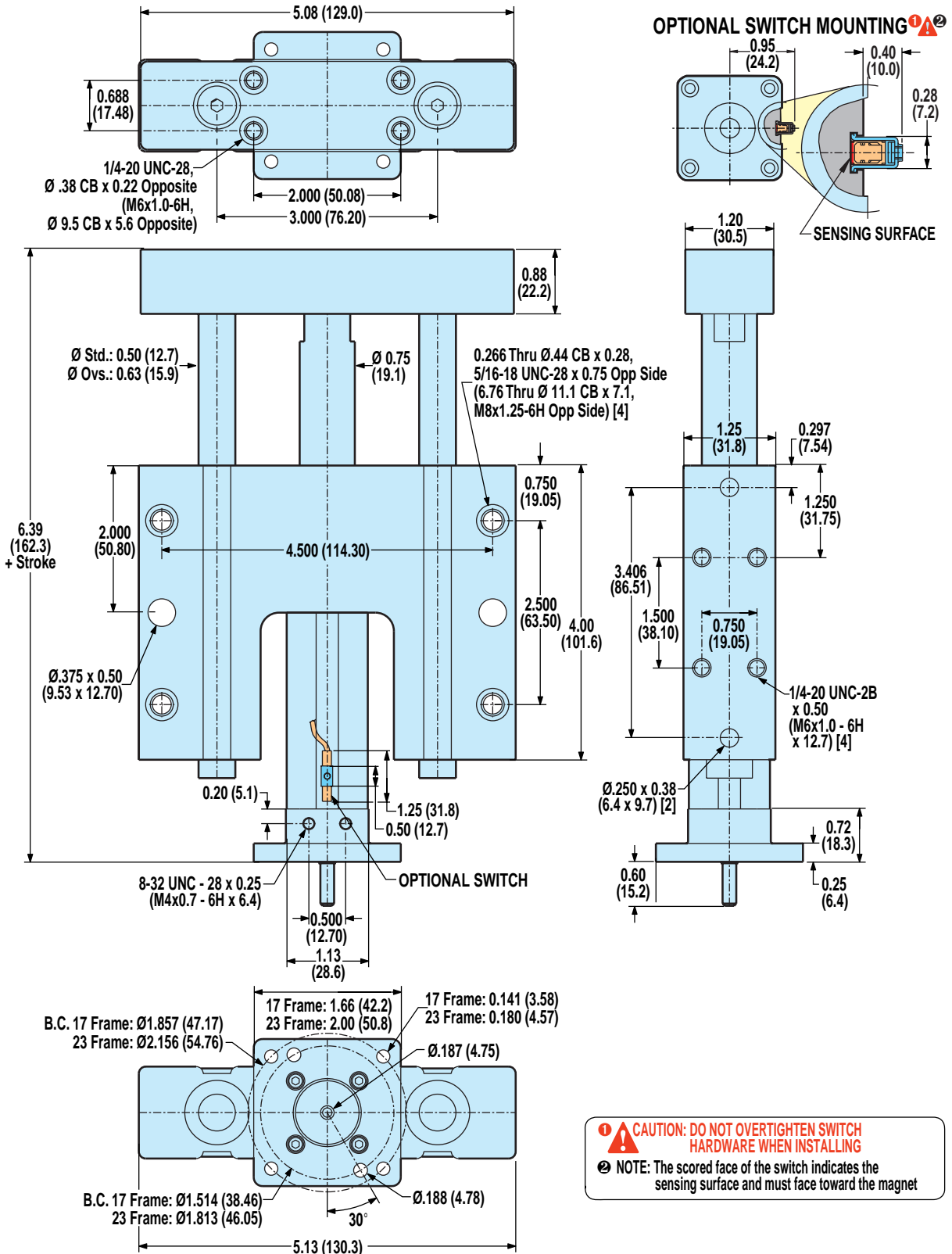

⚠ CAUTION: DO NOT OVERTIGHTEN SWITCH HARDWARE WHEN INSTALLING

Ⓜ NOTE: The scored face of the switch indicates the sensing surface and must face toward the magnet

Unless otherwise noted, all dimensions shown are in inches (Dimensions in parenthesis are in millimeters)

DIMENSIONS

GSA/GSM12 REVERSE PARALLEL (RP) BASE MODEL OPTIONS AND SWITCH MOUNTING

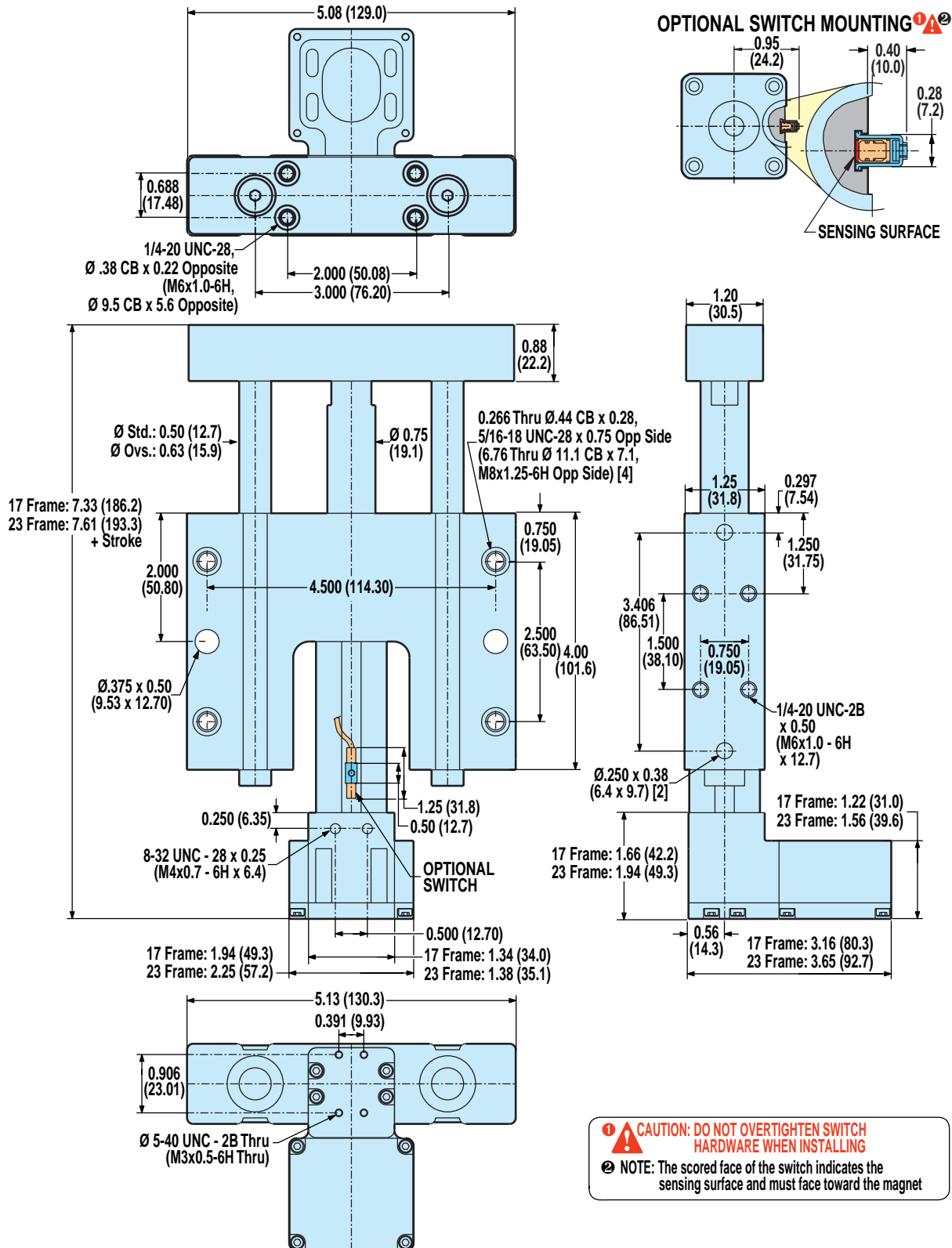

Axi dyne® GSA/GSM12 Series

DIMENSIONS

GSA/GSM12: IN-LINE MOUNTING FOR 17-FRAME MOTORS

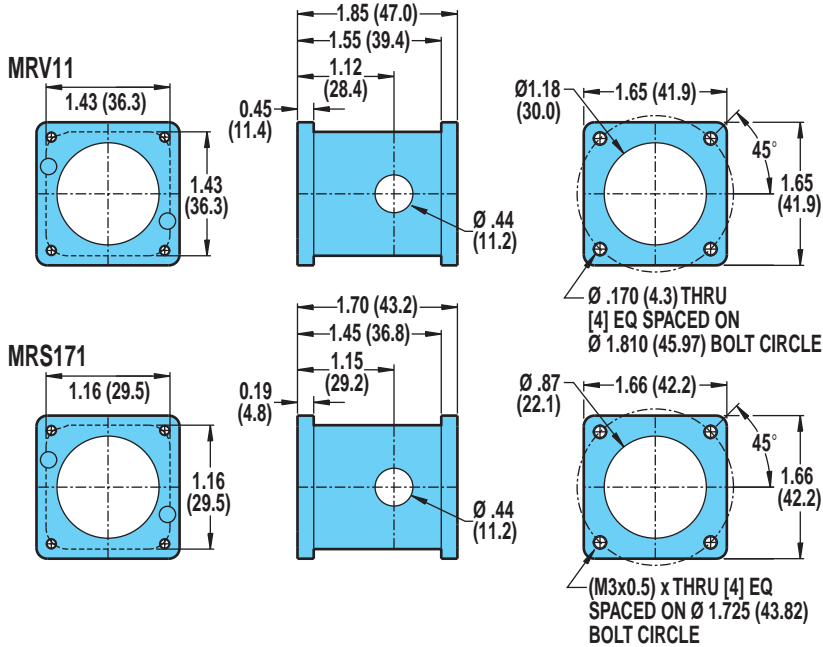

Gearheads are not available for the GSA/GSM12.

For a complete part listing of screw-drive motor and gear-head mounting kits referencing actuator/motor/coupler compatibilities, refer to document 3600-4631 available on the Literature/Part Sheets/Axidyne section of our web site at: www.tolomatic.com.



GUIDED SCREW

GSA/GSM12 Series

- In-line motor mounting

GSA/GSM12: IN-LINE MOUNTING FOR 23-FRAME MOTORS

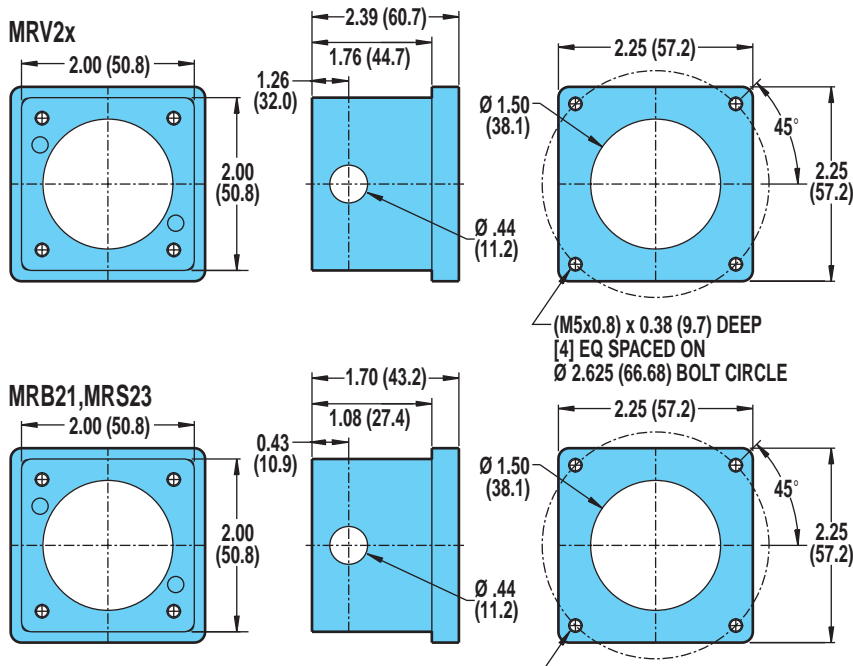

Gearheads are not available for the GSA/GSM12.

For a complete part listing of screw-drive motor and gear-head mounting kits referencing actuator/motor/coupler compatibilities, refer to document 3600-4631 available on the Literature/Part Sheets/Axidyne section of our web site at: www.tolomatic.com.

Axi dyne® GSA/GSM12 Series

DIMENSIONS

GSA/GSM12: REVERSE PARALLEL MOTOR MOUNTING

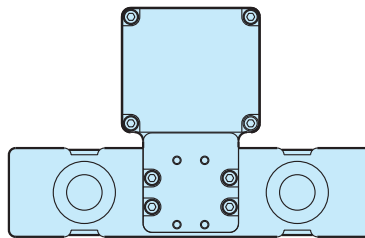
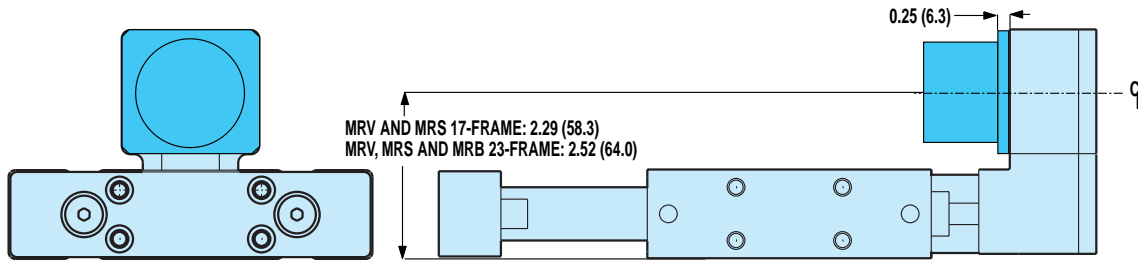

GUIDED SCREW

GSA/GSM12 Series

- Reverse parallel motor mounting

SPECIFICATIONS

MOTOR	REDUCTION INERTIA AT MOTOR SHAFT	
	1:1	
	lb-in ²	kg-m ² x 10 ⁻⁴ x 10 ⁻⁴
BRUSHLESS	MRV11	0.001 0.289
	MRV21, 22, 23, 24	0.037 10.676
STEPPER	MRS171	0.001 0.296
	MRS231, 232	0.007 1.913
BRUSHED	MRB21	0.007 1.920

REDUCTION EFFICIENCY: 0.95

Axi-dyne® GSA/GSM16 Series ACME SCREW SPECIFICATIONS

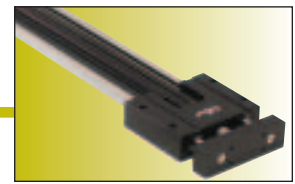

GSA16 ACME SCREW CRITICAL SPEED AND PV LIMITS

CRITICAL SPEED WITH 0.375" 1TPI ENGLISH ACME SCREW

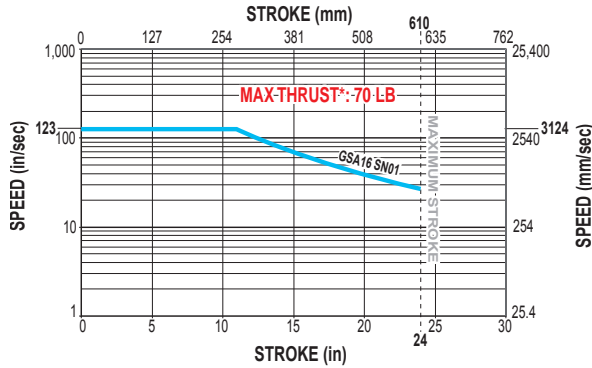

PV LIMITS: 0.375" 1TPI ENGLISH ACME SCREW

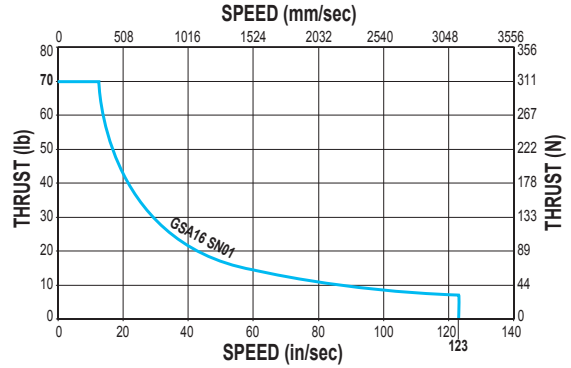

CRITICAL SPEED WITH 0.375" 2TPI ENGLISH ACME SCREW

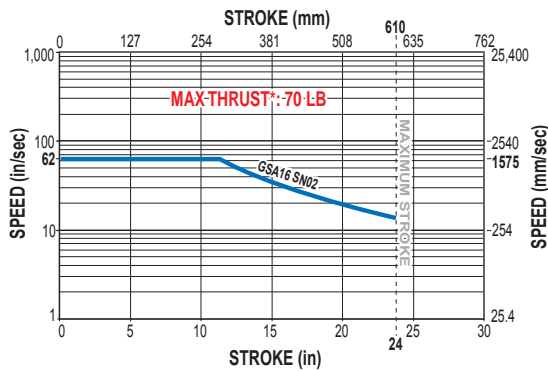

PV LIMITS: 0.375" 2TPI ENGLISH ACME SCREW

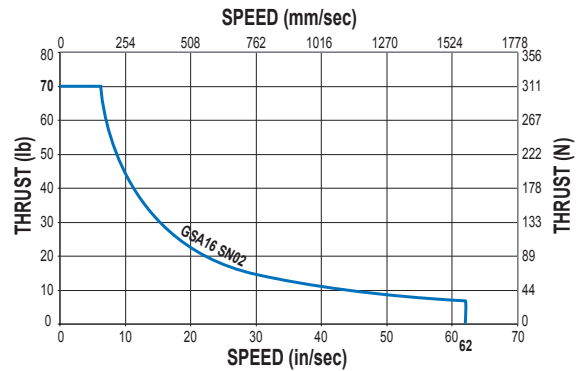

CRITICAL SPEED WITH 0.375" 5TPI ENGLISH ACME SCREW

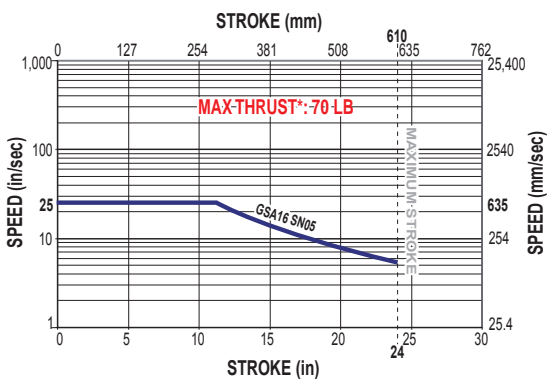

PV LIMITS: 0.375" 5TPI ENGLISH ACME SCREW

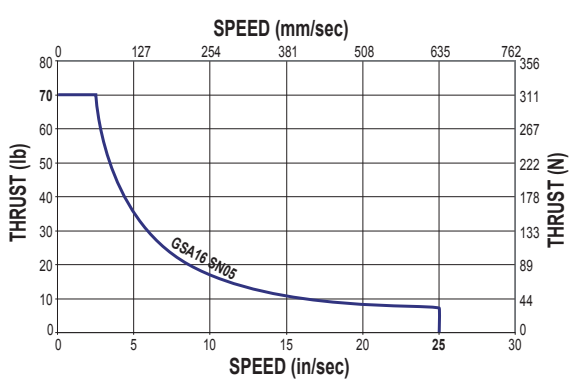

SN = Solid Nut



* Maximum thrust is the maximum continuous dynamic thrust subject to Thrust x Velocity limitation.

PV LIMITS: Any material which carries a sliding load is limited by heat buildup. The factors that affect heat generation rate in an application are the pressure on the nut in pounds per square inch and the surface velocity in feet per minute. The product of these factors provides a measure of the severity of an application.

$$P = \frac{\text{Thrust}}{\text{Max. Thrust Rating}} \times V = \frac{\text{Speed}}{\text{Max. Speed Rating}} \leq 0.1$$



GUIDED SCREW

GSA/GSM16 Series

- Acme screw critical speed and PV limits

Axi-dyne® GSA/GSMI6 Series

ACME AND BALL SCREW SPECIFICATIONS

GSA16 ACME SCREW CRITICAL SPEED AND PV LIMITS (continued)

CRITICAL SPEED WITH 0.375" 10TPI ENGLISH ACME SCREW

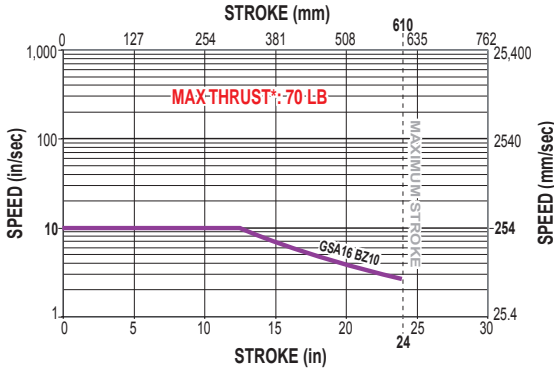

PV LIMITS: 0.375" 10TPI ENGLISH ACME SCREW

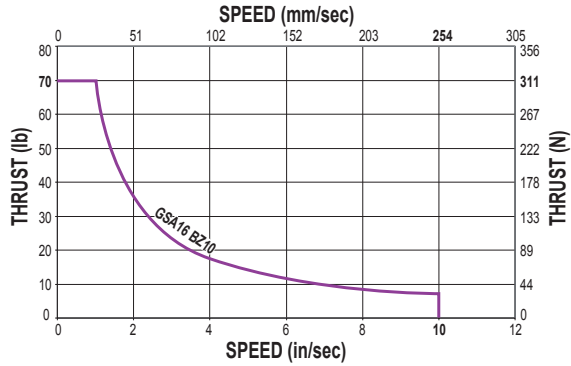

BZ = Bronze Nut



* Maximum thrust is the maximum continuous dynamic thrust subject to Thrust x Velocity limitation.

PV LIMITS: Any material which carries a sliding load is limited by heat buildup. The factors that affect heat generation rate in an application are the pressure on the nut in pounds per square inch and the surface velocity in feet per minute. The product of these factors provides a measure of the severity of an application.

$$P = \frac{\text{Thrust}}{\text{Max. Thrust Rating}} \times V = \frac{\text{Speed}}{\text{Max. Speed Rating}} \leq 0.1$$



GUIDED SCREW

GSA/GSMI6 Series

- Acme screw critical speed and PV limits
- Ball screw critical speed and life calculations

GSA16 BALL SCREW CRITICAL SPEED AND LIFE CALCULATIONS

CRITICAL SPEED WITH 0.375" 8TPI ENGLISH BALL SCREW

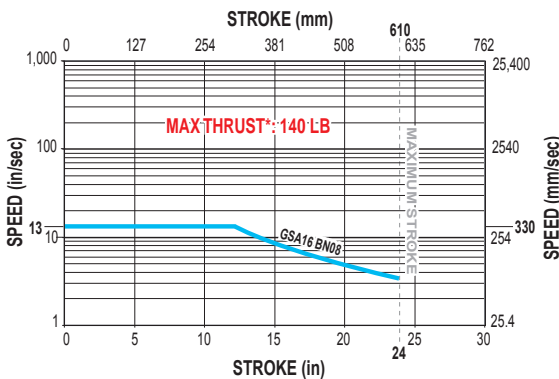

LIFE CALCULATION: 0.375" 8TPI ENGLISH BALL SCREW

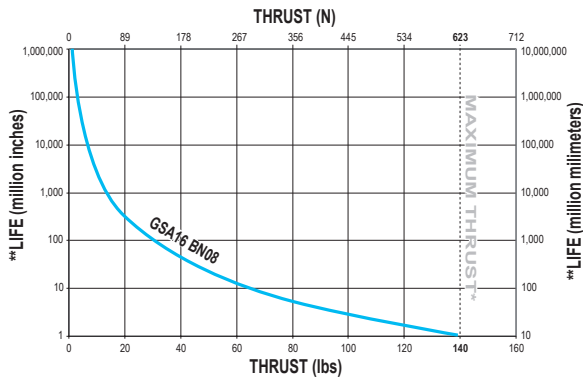

BN = Ball Nut



* Maximum thrust reflects 90% reliability for 1 million linear inches of travel.

**Life indicates theoretical maximum life of screw only, under ideal conditions and does not indicate expected life of actuator.

Axi-dyne® GSA/GSM16 Series

PERFORMANCE DATA

GSA/GSM16 MAXIMUM LOAD WEIGHT AND GUIDE ROD DEFLECTION

MAXIMUM LOAD WEIGHT vs STROKE LENGTH
LINEAR BALL BEARING, STANDARD GUIDE RODS

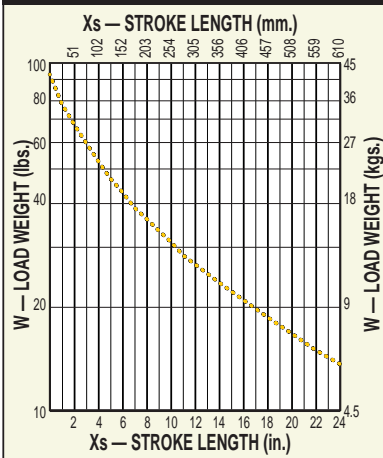

Linear ball bearings are not available with stainless-steel guide rod option.

MAXIMUM LOAD WEIGHT vs STROKE LENGTH
COMPOSITE BEARING, STANDARD GUIDE RODS

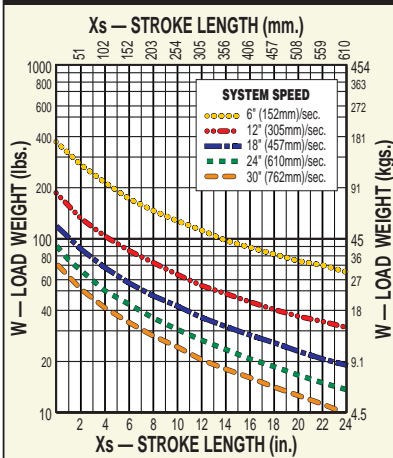

MAXIMUM LOAD WEIGHT vs STROKE LENGTH
COMPOSITE BEARING, OVERSIZE GUIDE RODS

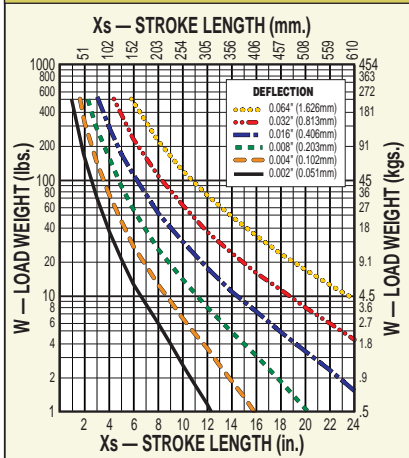

GUIDE ROD DEFLECTION
STANDARD GUIDE RODS

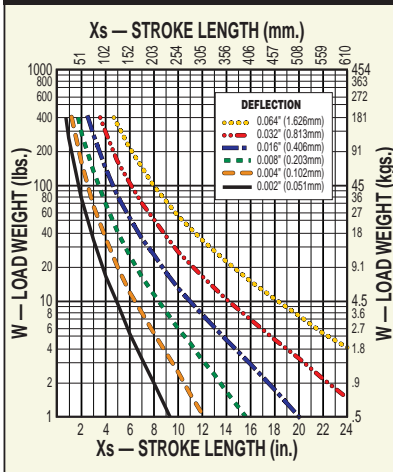

GUIDE ROD DEFLECTION
OVERSIZE GUIDE RODS

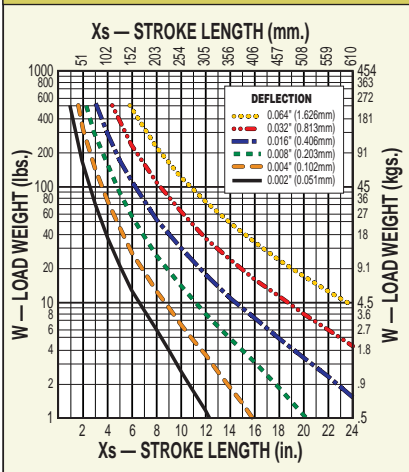

GUIDED SCREW

GSA/GSM16 Series

- Maximum load weight and guide rod deflection

DO NOT EXCEED MAXIMUM LOAD CURVE

Maximum load values are based on 200 million linear inches of travel.

1. To obtain most accurate results, stroke length should be adjusted by the distance between the center of mass of the load and tooling plate.

$$X_{adj} = X_s + X_{cm}$$

Then, use X_{adj} instead of X_s on the Maximum Load Weight vs. Stroke Length graph.

2. For the off-center loads, calculate adjusted load weight using the following formula:

$$W_{adj} = W (1 + 0.53 Y_{cm})$$

where Y_{cm} is distance between center of mass of off-center load and center of tooling plate.

Then, use W_{adj} instead of W on Maximum Load Weight vs. Stroke Length graph.

3. Using your stroke length and load weight, evaluate guide rod deflection. If the intersection point is above the highest curve (.064"), contact Tol-O-Matic for assistance.

- Impact loading is not recommended for GSA/GSM actuators.
- Motor breaks may be required on vertically positioned actuators with plastic (solid) or ball nuts in applications with risk of load backdriving. (Actuators with bronze nuts will not backdrive for loads, thrusts within catalog specifications.)

Contact Tol-O-Matic for assistance.

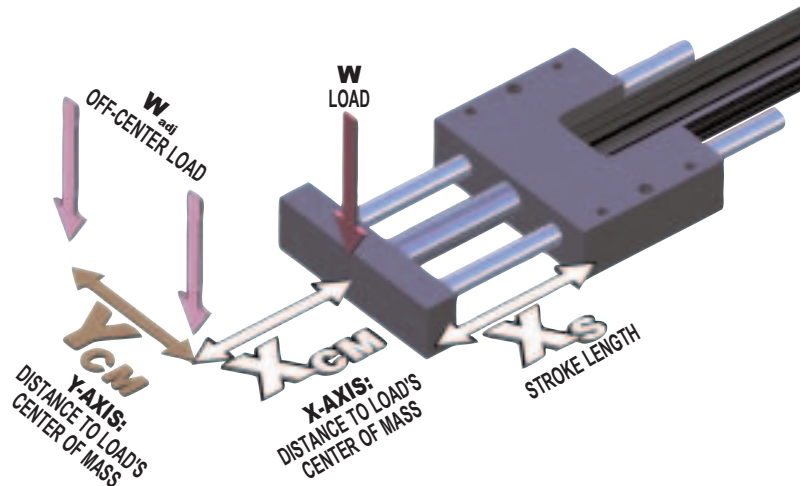

Axi-dyne® GSA/GSM16 Series

DIMENSIONS

GSA/GSM16 IN-LINE (LMI) BASE MODEL AND SWITCH MOUNTING

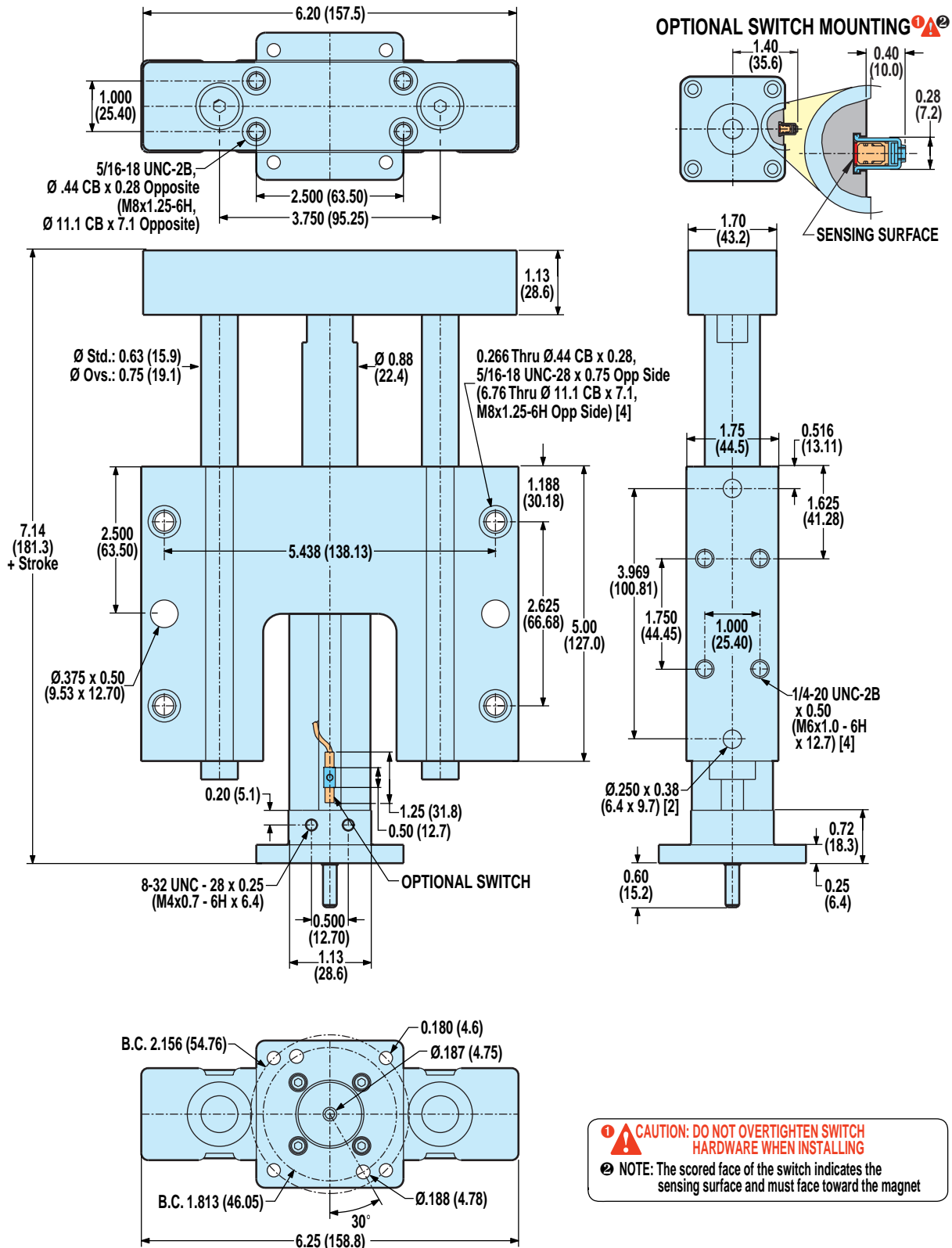

GUIDED SCREW

GSA/GSM16 Series

- In-line base model dimensions

Unless otherwise noted, all dimensions shown are in inches (Dimensions in parenthesis are in millimeters)

Axi dyne® GSA/GSM16 Series

DIMENSIONS

GSA/GSM16 REVERSE PARALLEL (RP) BASE MODEL OPTIONS AND SWITCH MOUNTING

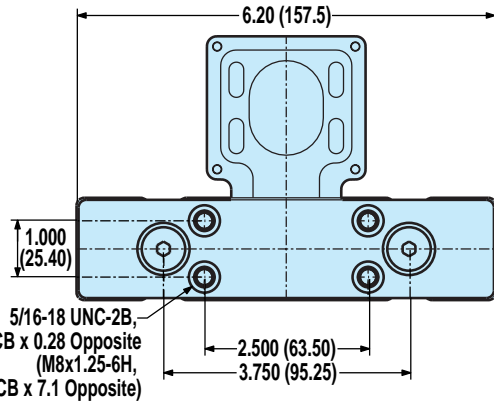

OPTIONAL SWITCH MOUNTING ¹⚠ ²

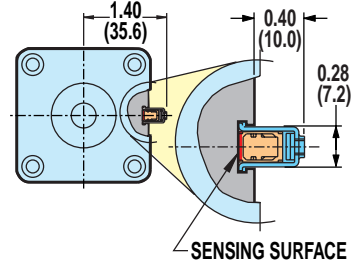

GUIDED SCREW

GSA/GSM16 Series

- Reverse parallel base model dimensions

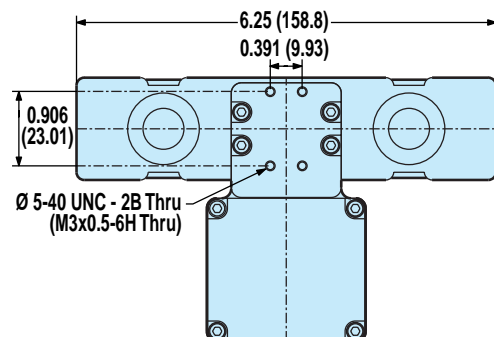
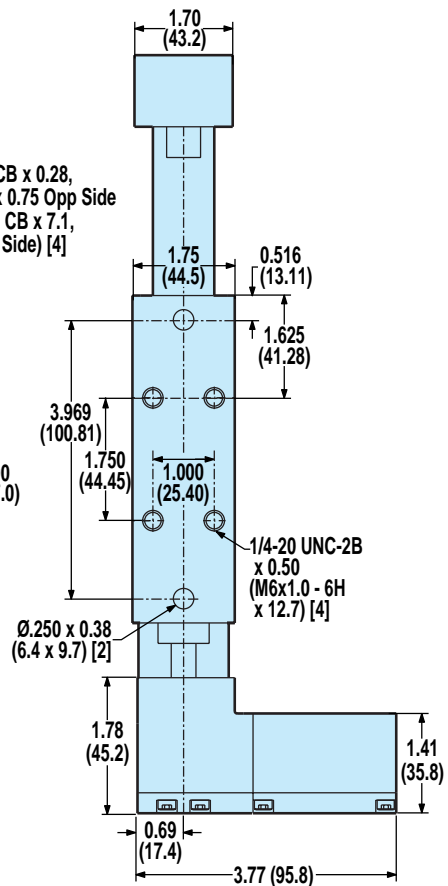
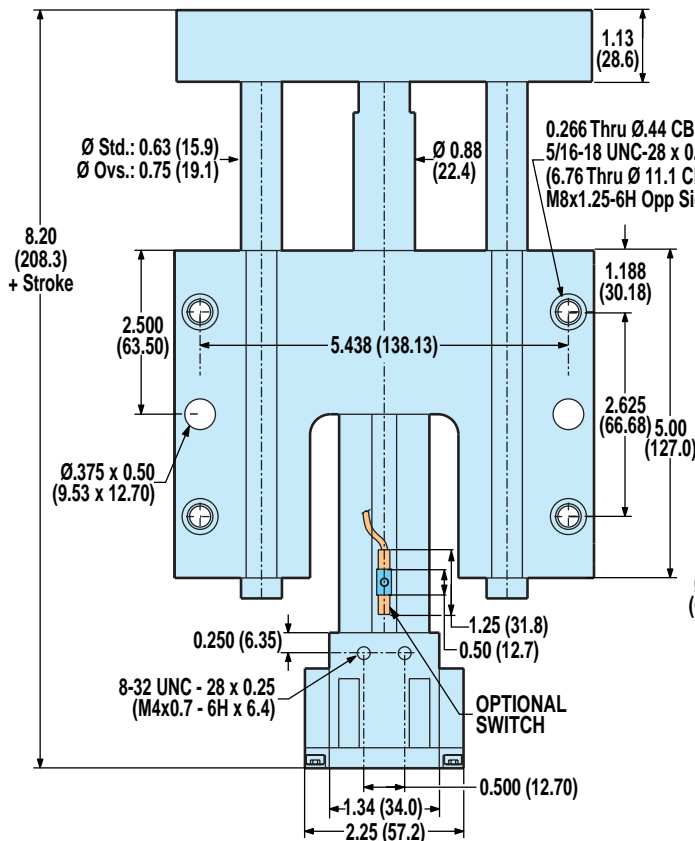

- ⚠ CAUTION: DO NOT OVERTIGHTEN SWITCH HARDWARE WHEN INSTALLING**
- Ⓜ NOTE: The scored face of the switch indicates the sensing surface and must face toward the magnet**

DIMENSIONS

GSA/GSM16: IN-LINE MOTOR MOUNTING

MRV2x

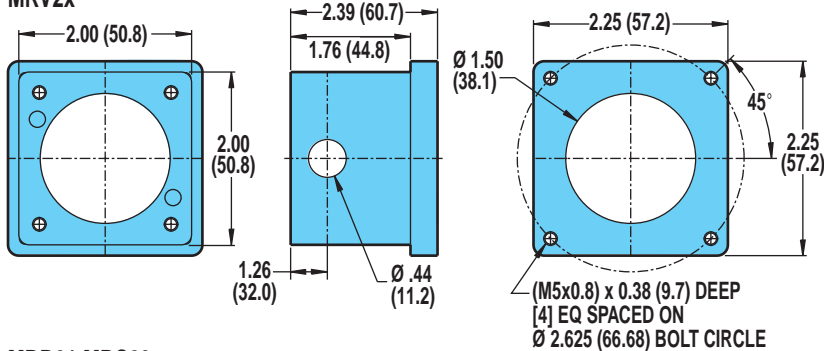

Gearheads are not available for the GSA/GSM16

For a complete part listing of screw-drive motor and gearhead mounting kits referencing actuator/motor/coupler compatibilities, refer to document 3600-4631 available on the Literature/Part Sheets/Axidyne section of our web site at: www.tolomatic.com.

MRB21, MRS23x

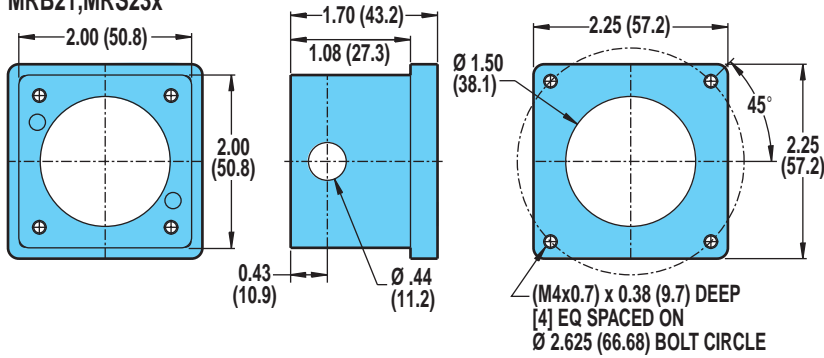

GUIDED SCREW

GSA/GSM16 Series

- In-line motor mounting
- Reverse parallel motor mounting

GSA/GSM16: REVERSE PARALLEL MOTOR MOUNTING

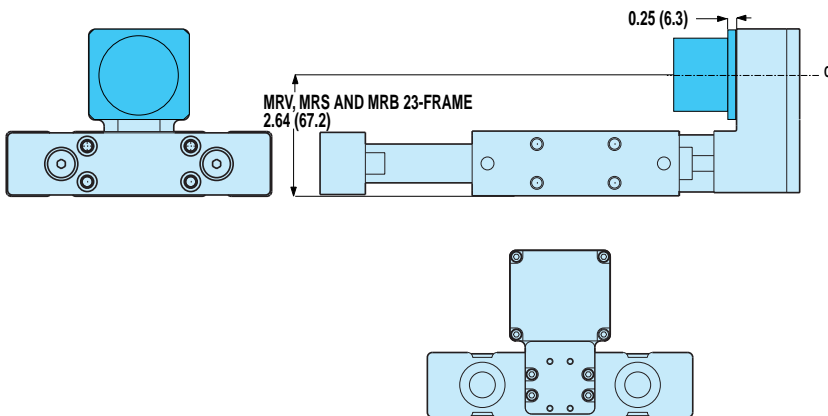

SPECIFICATIONS

	MOTOR	REDUCTION INERTIA AT MOTOR SHAFT	
		1:1	
		lb-in ²	kg-m ² x 10 ⁻⁴
BRUSHLESS	MRV21, 22, 23, 24	0.037	10.676
STEPPER	MRS231, 232	0.007	1.913
BRUSHED	MRB21	0.007	1.920

REDUCTION EFFICIENCY: 0.95

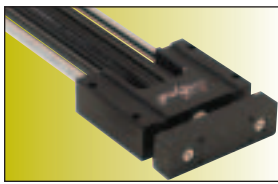

Axi-dyne® GSA/GSM24 Series ACME SCREW SPECIFICATIONS

GSA24 ACME SCREW CRITICAL SPEED AND PV LIMITS

CRITICAL SPEED WITH 0.625" 2TPI ENGLISH ACME SCREW

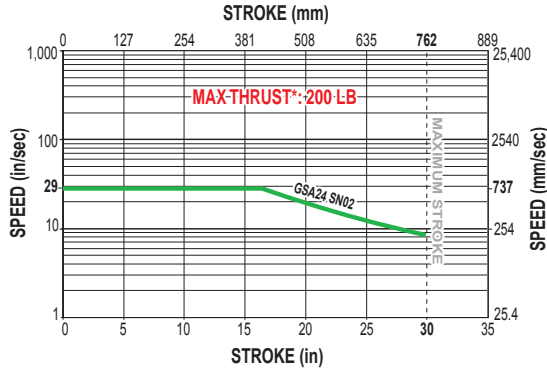

PV LIMITS: 0.625" 2TPI ENGLISH ACME SCREW

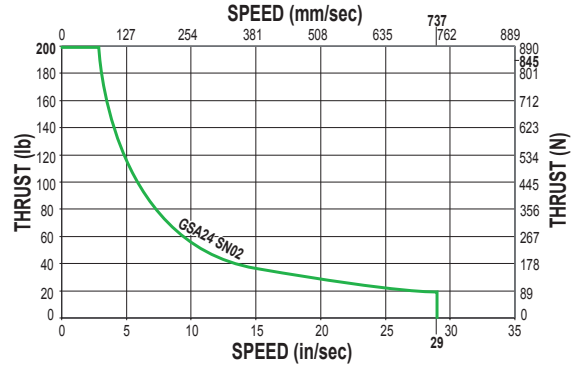

CRITICAL SPEED WITH 0.625" 4TPI ENGLISH ACME SCREW

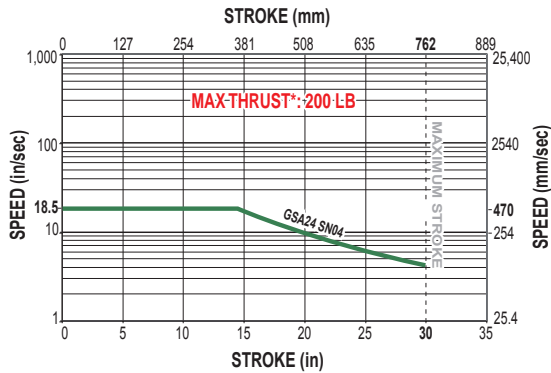

PV LIMITS: 0.625" 4TPI ENGLISH ACME SCREW

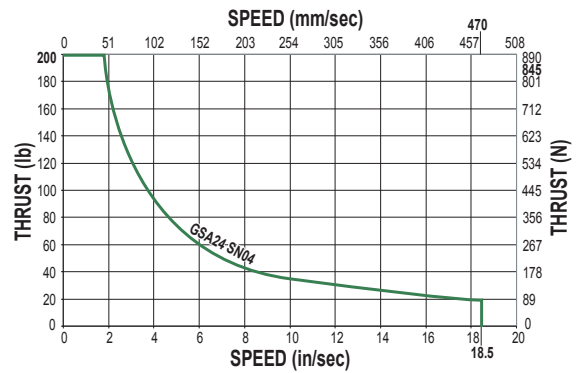

CRITICAL SPEED WITH 0.625" 8TPI ENGLISH ACME SCREW

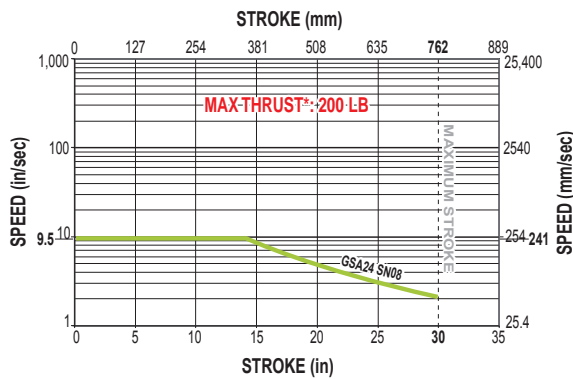

PV LIMITS: 0.625" 8TPI ENGLISH ACME SCREW

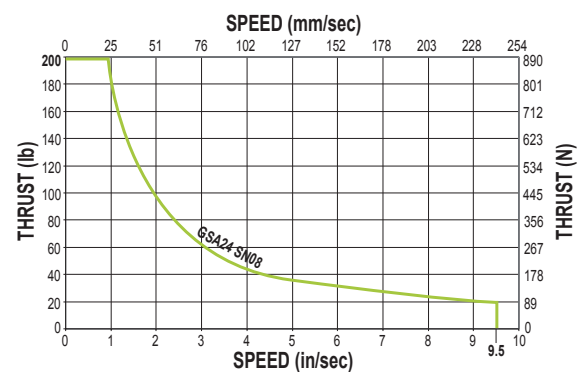

SN = Solid Nut



* *Maximum thrust is the maximum continuous dynamic thrust subject to Thrust x Velocity limitation.*

PV LIMITS: Any material which carries a sliding load is limited by heat buildup. The factors that affect heat generation rate in an application are the pressure on the nut in pounds per square inch and the surface velocity in feet per minute. The product of these factors provides a measure of the severity of an application.

$$P = \frac{\text{Thrust}}{\text{Max. Thrust Rating}} \times V = \frac{\text{Speed}}{\text{Max. Speed Rating}} \leq 0.1$$

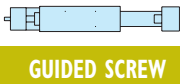

GUIDED SCREW

GSA/GSM24 Series

- Acme screw critical speed and PV limits

Axi-dyne® GSA/GSA24 Series

ACME AND BALL SCREW SPECIFICATIONS

GSA24 ACME SCREW CRITICAL SPEED AND PV LIMITS (continued)

CRITICAL SPEED WITH 0.625" 10TPI ENGLISH ACME SCREW

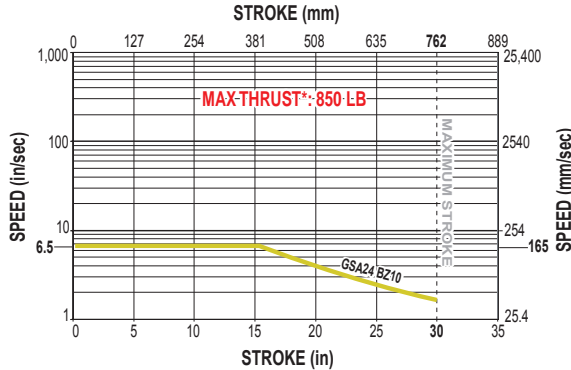

PV LIMITS: 0.625" 10TPI ENGLISH ACME SCREW

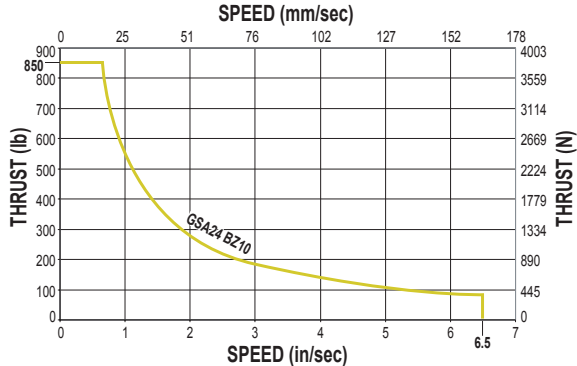

BZ = Bronze Nut



* Maximum thrust is the maximum continuous dynamic thrust subject to Thrust x Velocity limitation.

PV LIMITS: Any material which carries a sliding load is limited by heat buildup. The factors that affect heat generation rate in an application are the pressure on the nut in pounds per square inch and the surface velocity in feet per minute. The product of these factors provides a measure of the severity of an application.

$$P = \frac{\text{Thrust}}{\text{Max. Thrust Rating}} \times V = \frac{\text{Speed}}{\text{Max. Speed Rating}} \leq 0.1$$



GUIDED SCREW

GSA/GSM24 Series

- Acme screw critical speed and PV limits
- Ball screw critical speed and life calculations

GSA24 BALL SCREW CRITICAL SPEED AND LIFE CALCULATIONS

CRITICAL SPEED WITH 0.625" 5TPI ENGLISH BALL SCREW

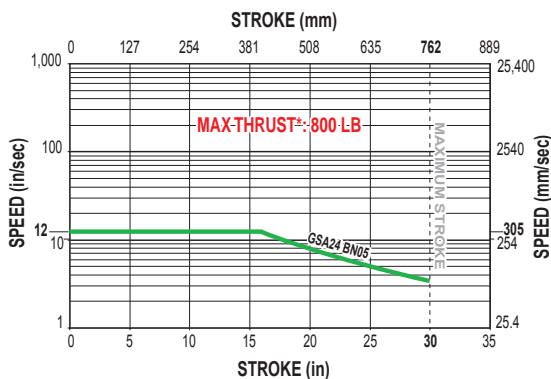

LIFE CALCULATION: 0.625" 5TPI ENGLISH BALL SCREW

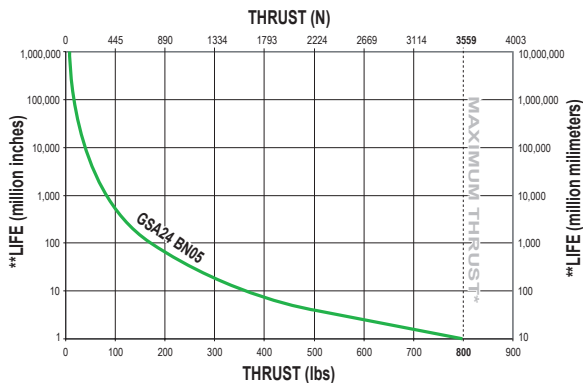

BN = Ball Nut



* Maximum thrust reflects 90% reliability for 1 million linear inches of travel.

**Life indicates theoretical maximum life of screw only, under ideal conditions and does not indicate expected life of actuator.

Axi-dyne® GSA/GSM24 Series

PERFORMANCE DATA

GSA/GSM24 MAXIMUM LOAD WEIGHT AND GUIDE ROD DEFLECTION

MAXIMUM LOAD WEIGHT vs STROKE LENGTH
LINEAR BALL BEARING, STANDARD GUIDE RODS

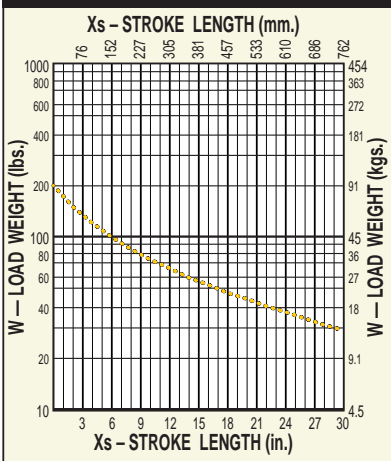

Linear ball bearings are not available with stainless-steel guide rod option.

MAXIMUM LOAD WEIGHT vs STROKE LENGTH
COMPOSITE BEARING, STANDARD GUIDE RODS

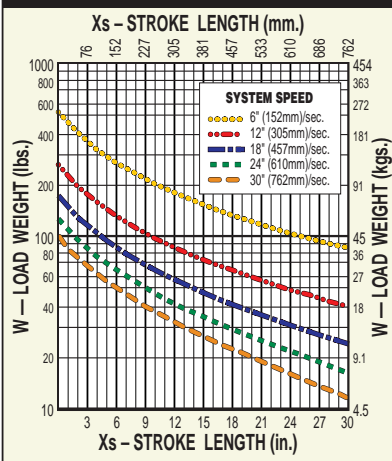

MAXIMUM LOAD WEIGHT vs STROKE LENGTH
COMPOSITE BEARING, OVERSIZE GUIDE RODS

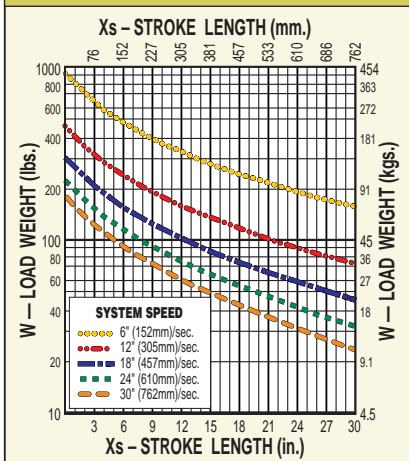

GUIDE ROD DEFLECTION
STANDARD GUIDE RODS

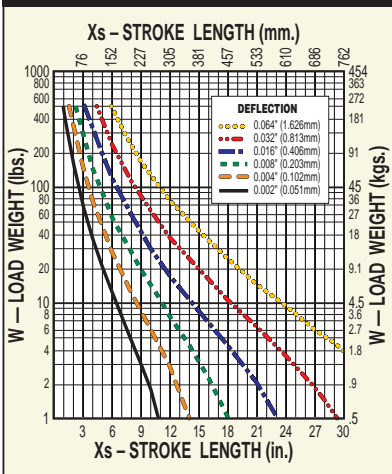

GUIDE ROD DEFLECTION
OVERSIZE GUIDE RODS

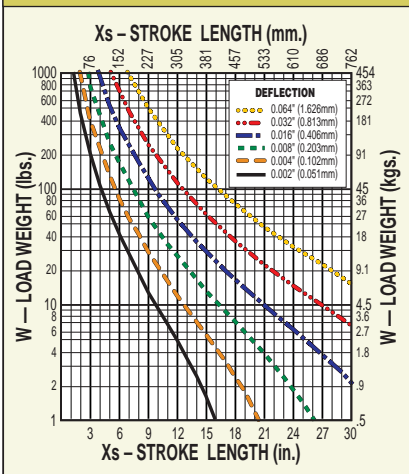

GUIDED SCREW

GSA/GSM24 Series

- Maximum load weight and rod deflection

DO NOT EXCEED MAXIMUM LOAD CURVE

Maximum load values are based on 200 million linear inches of travel.

1. To obtain most accurate results, stroke length should be adjusted by the distance between the center of mass of the load and tooling plate.

$$X_{adj} = X_s + X_{cm}$$

Then, use X_{adj} instead of X_s on the Maximum Load Weight vs. Stroke Length graph.

2. For the off-center loads, calculate adjusted load weight using the following formula:

$$W_{adj} = W (1 + 0.40 Y_{cm})$$

where Y_{cm} is distance between center of mass of off-center load and center of tooling plate.

Then, use W_{adj} instead of W on Maximum Load Weight vs. Stroke Length graph.

3. Using your stroke length and load weight, evaluate guide rod deflection. If the intersection point is above the highest curve (.064"), contact Tol-O-Matic for assistance.

- Impact loading is not recommended for GSA/GSM actuators.
- Motor breaks may be required on vertically positioned actuators with plastic (solid) or ball nuts in applications with risk of load backdriving. (Actuators with bronze nuts will not backdrive for loads, thrusts within catalog specifications.)

Contact Tol-O-Matic for assistance.

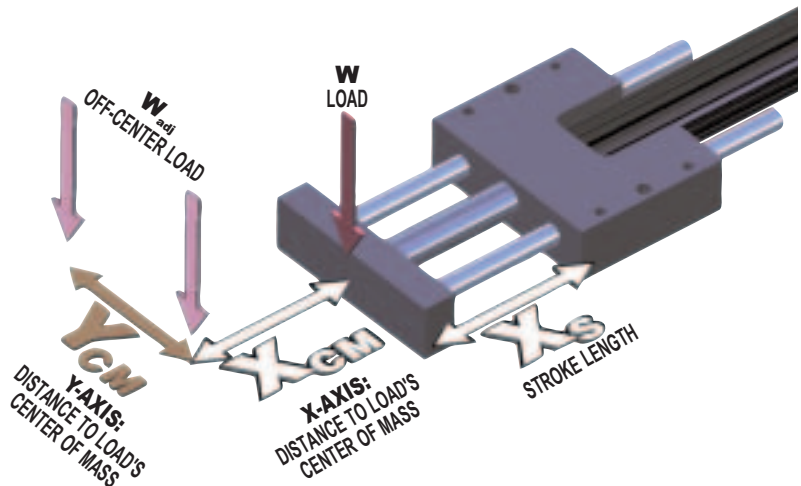

Axi dyne® GSA/GSM24 Series

DIMENSIONS

GSA/GSM24 IN-LINE (LMI) BASE MODEL AND SWITCH MOUNTING

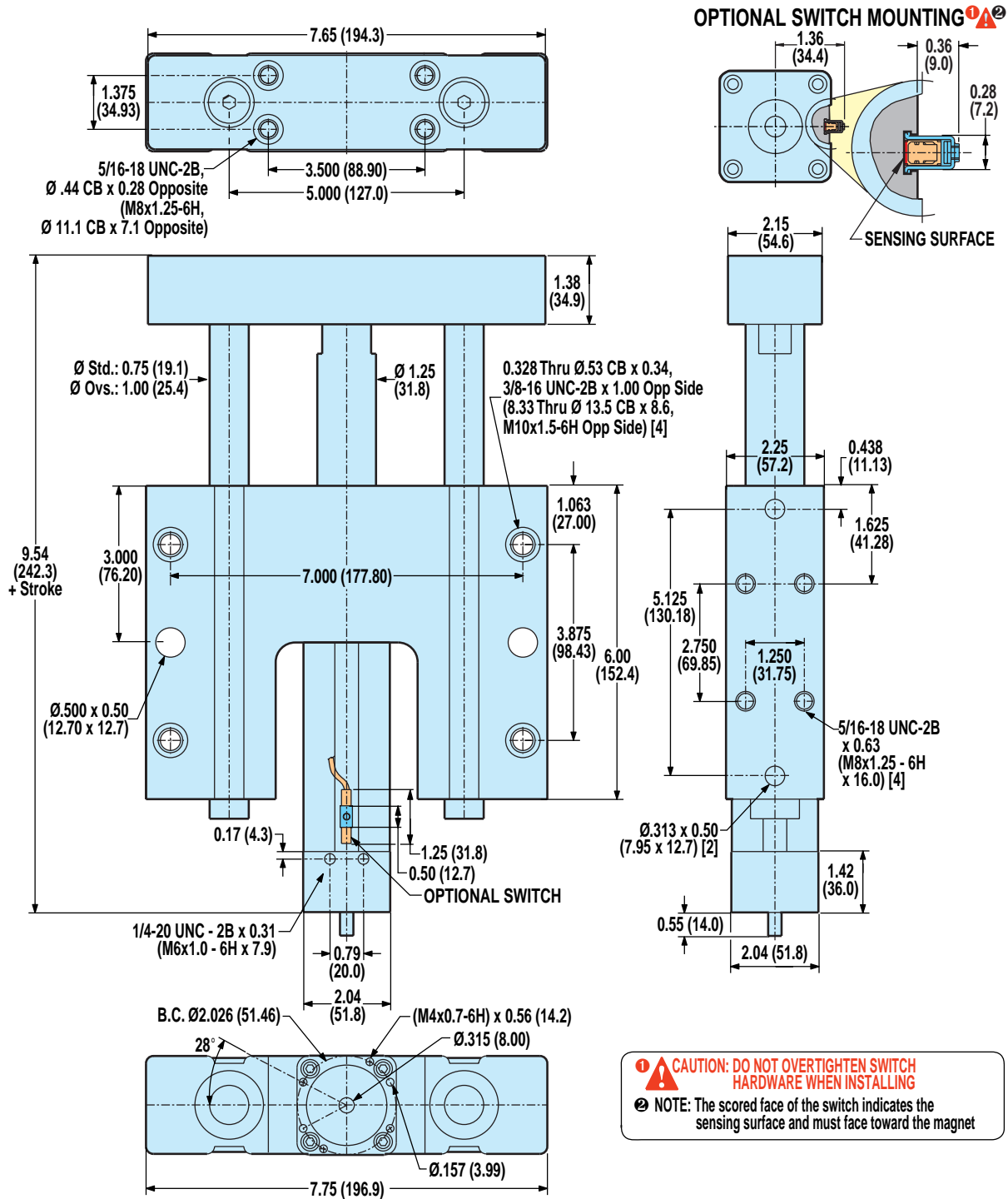

Unless otherwise noted, all dimensions shown are in inches (Dimensions in parenthesis are in millimeters)

Axi dyne® GSA/GSM24 Series

DIMENSIONS

GSA/GSM24 REVERSE PARALLEL (RP) BASE MODEL OPTIONS AND SWITCH MOUNTING

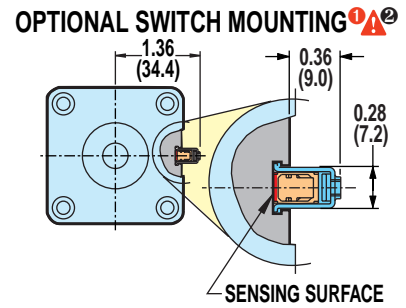
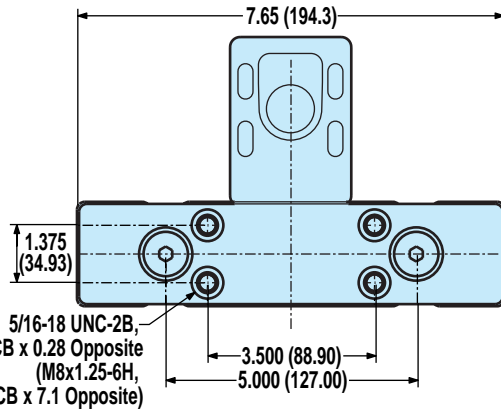

GUIDED SCREW

GSA/GSM24 Series

- Reverse parallel base model dimensions

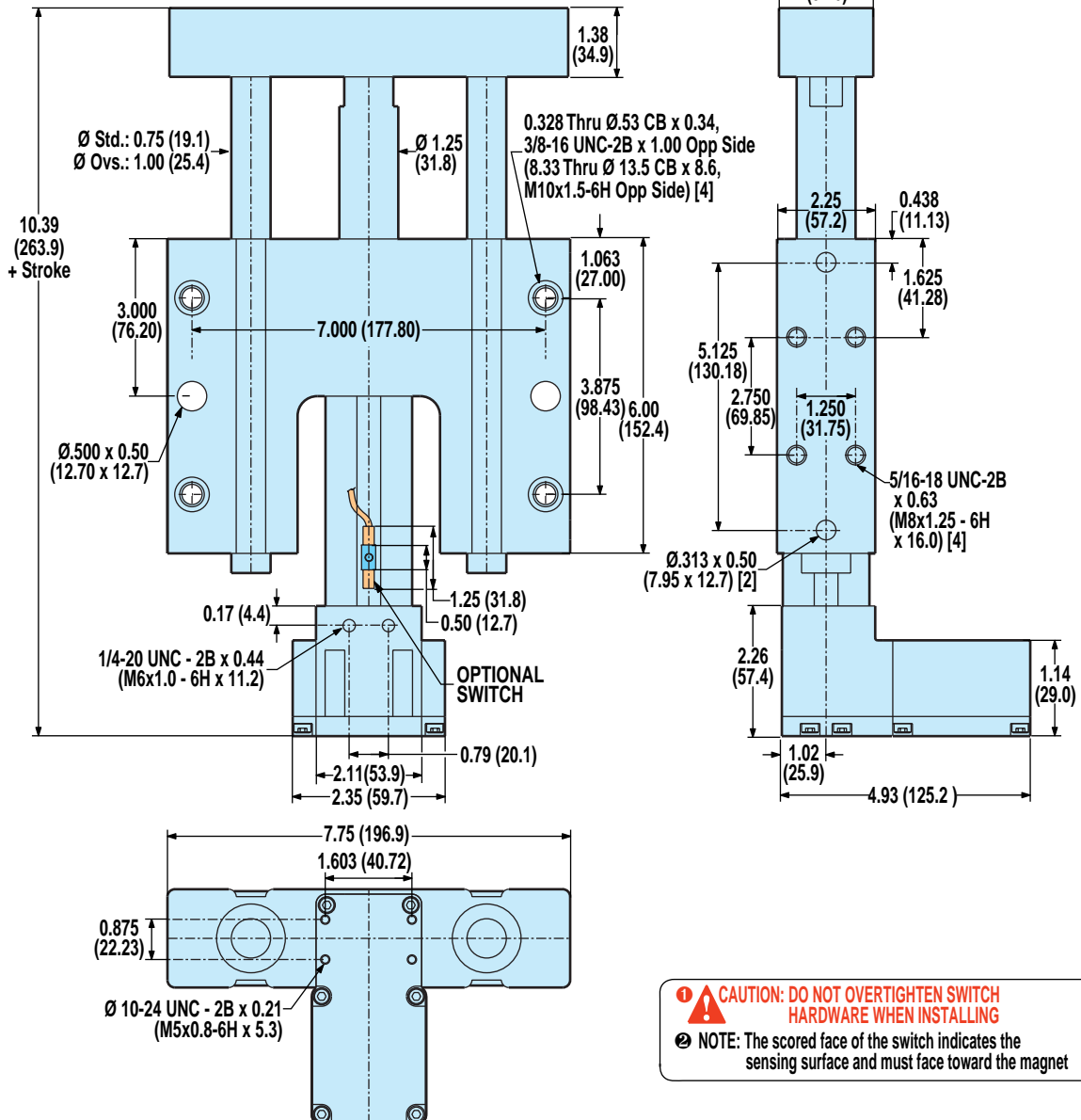

⚠️ CAUTION: DO NOT OVERTIGHTEN SWITCH HARDWARE WHEN INSTALLING

Ⓜ️ NOTE: The scored face of the switch indicates the sensing surface and must face toward the magnet

Axi dyne® GSA/GSM24 Series

DIMENSIONS

GSA/GSM24: IN-LINE MOUNTING FOR 23-FRAME MOTORS AND GEARHEADS

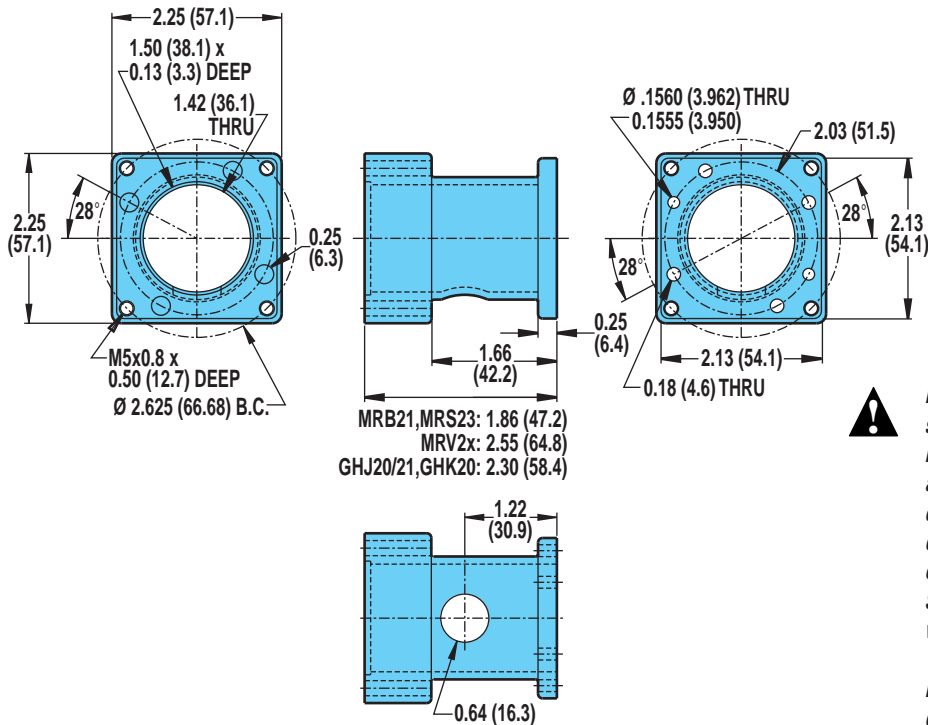

! For a complete part listing of screw-drive motor and gearhead mounting kits referencing actuator/motor/coupler compatibilities, refer to document 3600-4631 available on the Literature/Part Sheets/Axidyne section of our web site at: www.tolomatic.com.

For gearhead specifications and dimensions, see page F-10.



GUIDED SCREW

GSA/GSM24 Series

- In-line motor mounting
- Reverse parallel motor mounting

GSA/GSM24: REVERSE PARALLEL MOTOR MOUNTING

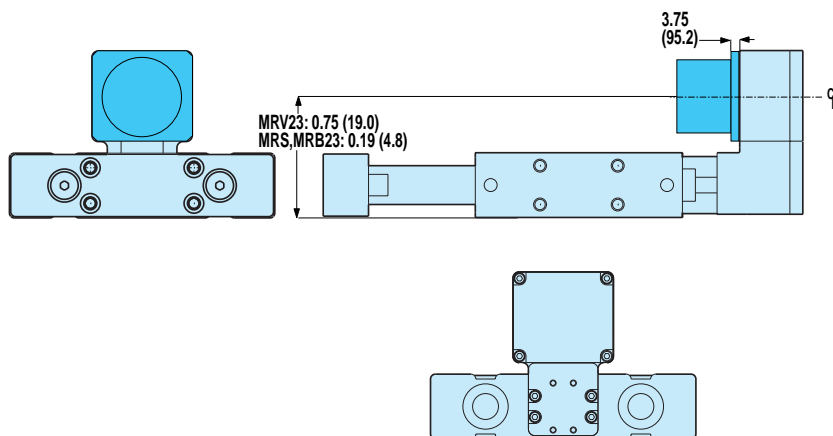

SPECIFICATIONS

MOTOR	REDUCTION INERTIA AT MOTOR SHAFT			
	1:1		2:1	
	lb-in ²	kg-m ² x 10 ⁻⁴	lb-in ²	kg-m ² x 10 ⁻⁴
BRUSHLESS MRV21, 22, 23, 24	0.008	2.320	0.029	8.599
STEPPER MRS231, 232	0.009	2.559	0.030	8.848
BRUSHED MRB21	0.009	2.564	0.030	8.843

REDUCTION EFFICIENCY: 0.95



Axi-dyne® GSA/GSM32 Series ACME SCREW SPECIFICATIONS

GSA32 ACME SCREW CRITICAL SPEED AND PV LIMITS

CRITICAL SPEED WITH 0.75" 1TPI ENGLISH ACME SCREW

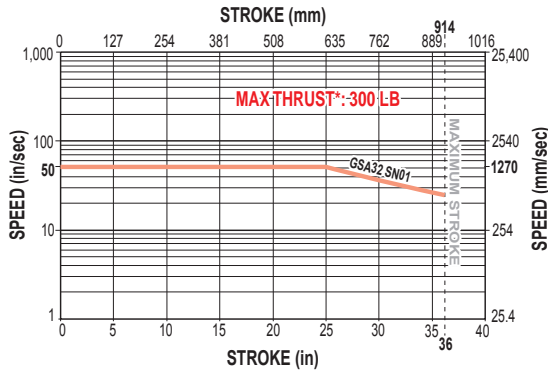

PV LIMITS: 0.75" 1TPI ENGLISH ACME SCREW

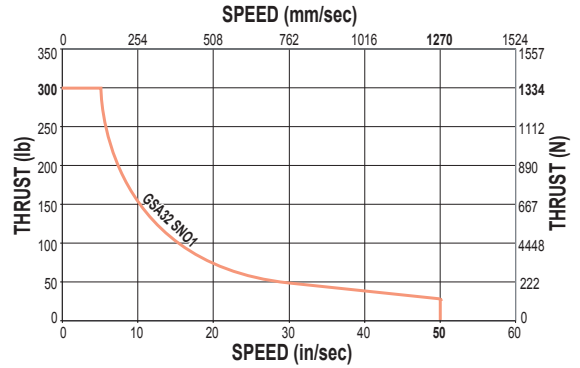

CRITICAL SPEED WITH 0.75" 2TPI ENGLISH ACME SCREW

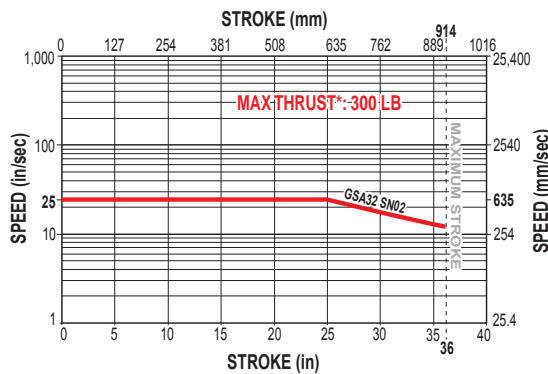

PV LIMITS: 0.75" 2TPI ENGLISH ACME SCREW

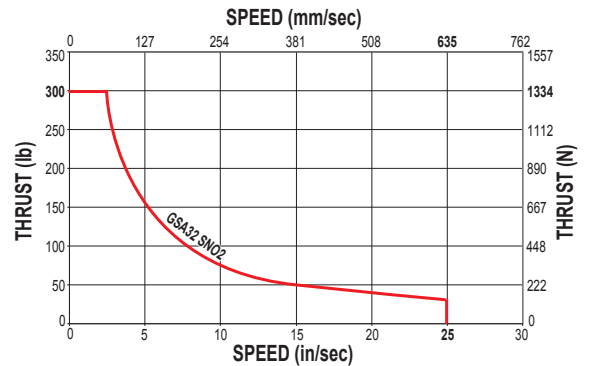

CRITICAL SPEED WITH 0.75" 10TPI ENGLISH ACME SCREW

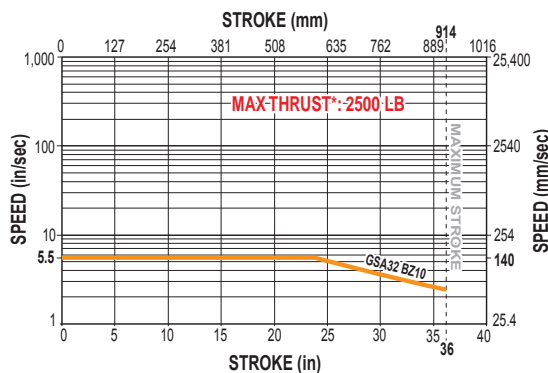

PV LIMITS: 0.75" 10TPI ENGLISH ACME SCREW

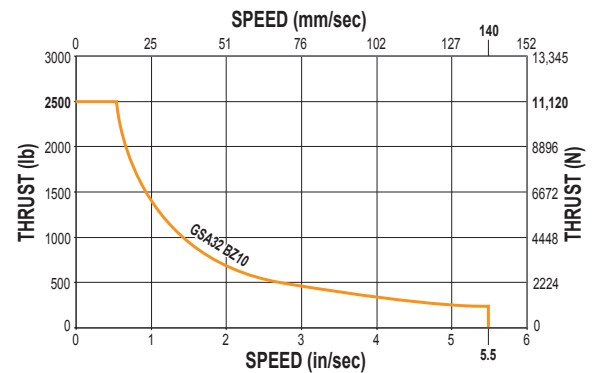

GUIDED SCREW

GSA/GSM32 Series

- Acme screw critical speed and PV limits

SN = Solid Nut

BZ= Bronze Nut



* *Maximum thrust is the maximum continuous dynamic thrust subject to Thrust x Velocity limitation.*

PV LIMITS: Any material which carries a sliding load is limited by heat buildup. The factors that affect heat generation rate in an application are the pressure on the nut in pounds per square inch and the surface velocity in feet per minute. The product of these factors provides a measure of the severity of an application.

$$P = \frac{\text{Thrust}}{\text{Max. Thrust Rating}} \times V = \frac{\text{Speed}}{\text{Max. Speed Rating}} \leq 0.1$$

Axi dyne® GSA/GSM32 Series

BALL SCREW SPECIFICATIONS

GSA32 BALL SCREW CRITICAL SPEED AND LIFE CALCULATIONS

CRITICAL SPEED WITH 0.75" 2TPI ENGLISH BALL SCREW

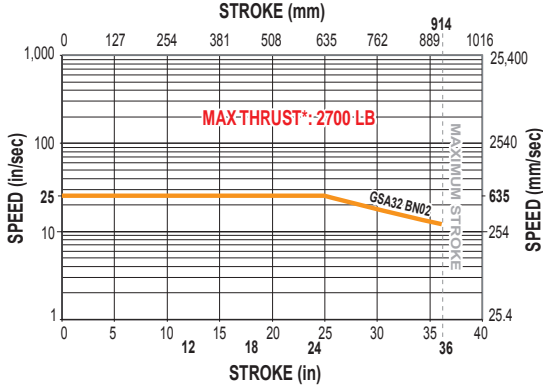

LIFE CALCULATION: 0.75" 2TPI ENGLISH BALL SCREW

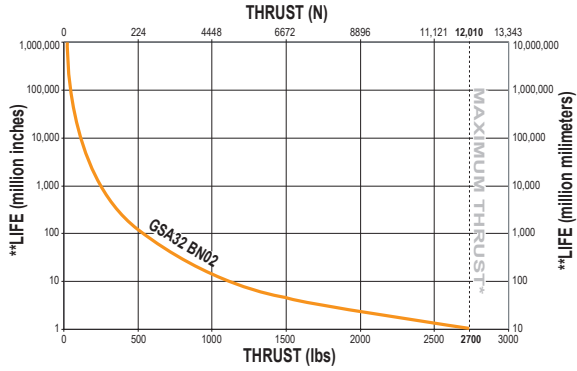

CRITICAL SPEED WITH 0.75" 5TPI ENGLISH BALL SCREW

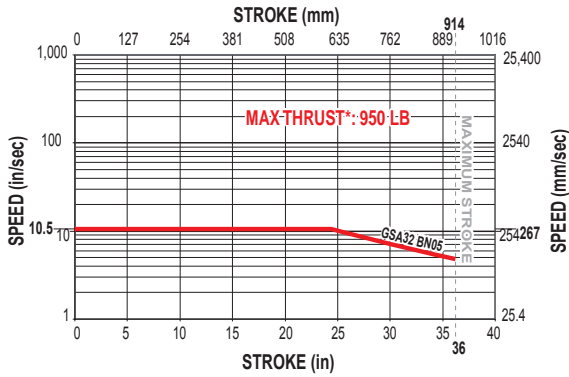

LIFE CALCULATION: 0.75" 5TPI ENGLISH BALL SCREW

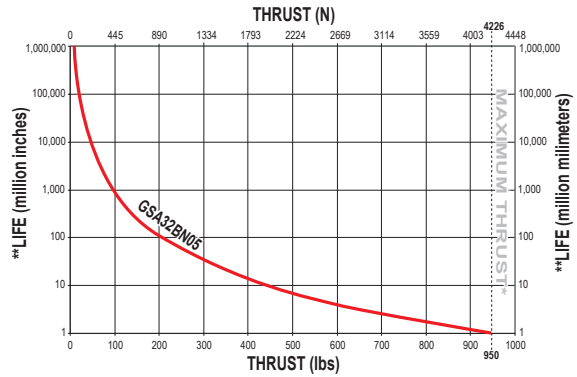

GUIDED SCREW

GSA/GSM32 Series

- Ball screw critical speed and life calculations

BN = Ball Nut



* Maximum thrust reflects 90% reliability for 1 million linear inches of travel.

**Life indicates theoretical maximum life of screw only, under ideal conditions and does not indicate expected life of actuator.

Axi-dyne® GSA/GSM32 Series

PERFORMANCE DATA

GSA/GSM32 MAXIMUM LOAD WEIGHT AND GUIDE ROD DEFLECTION

MAXIMUM LOAD WEIGHT vs STROKE LENGTH
LINEAR BALL BEARING, STANDARD GUIDE RODS

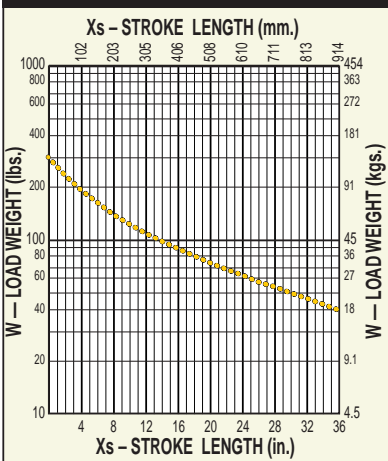

Linear ball bearings are not available with stainless-steel guide rod option.

MAXIMUM LOAD WEIGHT vs STROKE LENGTH
COMPOSITE BEARING, STANDARD GUIDE RODS

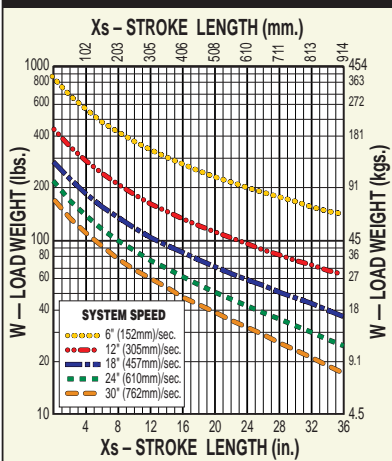

MAXIMUM LOAD WEIGHT vs STROKE LENGTH
COMPOSITE BEARING, OVERSIZE GUIDE RODS

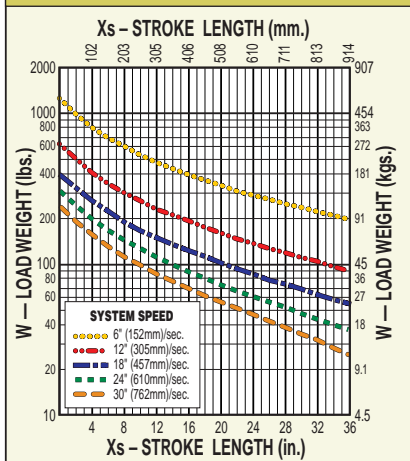

GUIDED SCREW

GSA/GSM32 Series

- Maximum load weight and rod deflection

DO NOT EXCEED MAXIMUM LOAD CURVE

Maximum load values are based on 200 million linear inches of travel.

1. To obtain most accurate results, stroke length should be adjusted by the distance between the center of mass of the load and tooling plate.

$$X_{adj} = X_s + X_{cm}$$

Then, use X_{adj} instead of X_s on the Maximum Load Weight vs. Stroke Length graph.

2. For the off-center loads, calculate adjusted load weight using the following formula:

$$W_{adj} = W (1 + 0.30 Y_{cm})$$

where Y_{cm} is distance between center of mass of off-center load and center of tooling plate.

Then, use W_{adj} instead of W on Maximum Load Weight vs. Stroke Length graph.

3. Using your stroke length and load weight, evaluate guide rod deflection. If the intersection point is above the highest curve (.064"), contact Tol-O-Matic for assistance.

- Impact loading is not recommended for GSA/GSM actuators.
- Motor breaks may be required on vertically positioned actuators with plastic (solid) or ball nuts in applications with risk of load backdriving. (Actuators with bronze nuts will not backdrive for loads, thrusts within catalog specifications.)

Contact Tol-O-Matic for assistance.

GUIDE ROD DEFLECTION
STANDARD GUIDE RODS

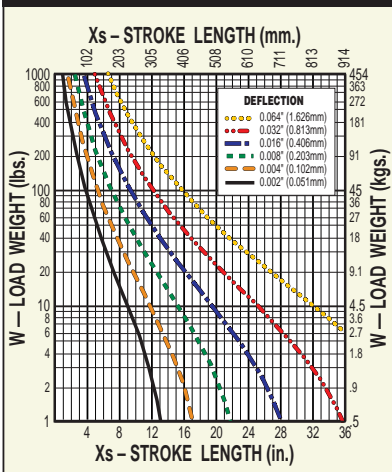

GUIDE ROD DEFLECTION
OVERSIZE GUIDE RODS

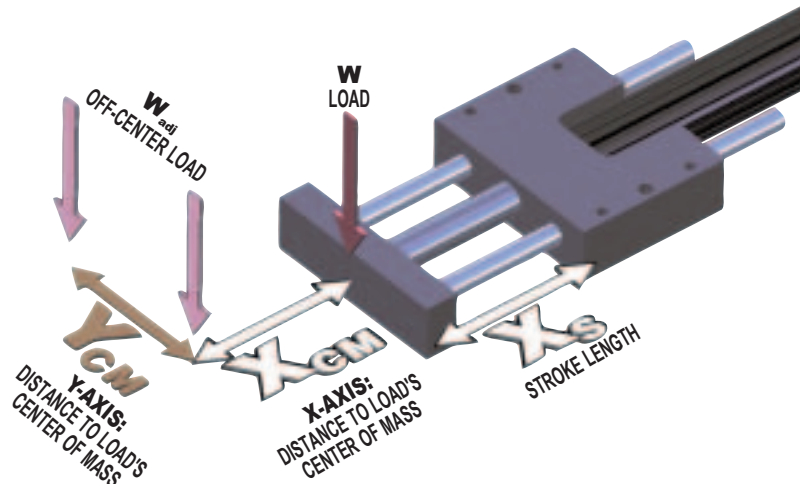
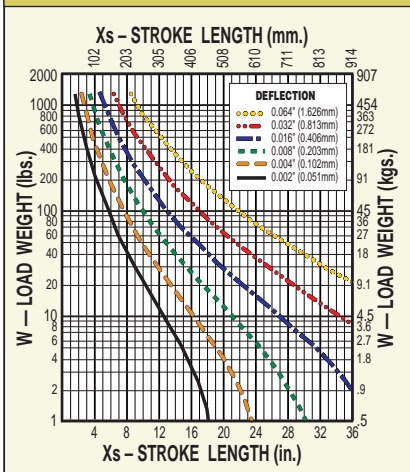

Axi dyne® GSA/GSM32 Series

DIMENSIONS

GSA/GSM32 REVERSE PARALLEL (RP) BASE MODEL OPTIONS AND SWITCH MOUNTING



GUIDED SCREW

GSA/GSM32 Series

- Reverse parallel base model dimensions

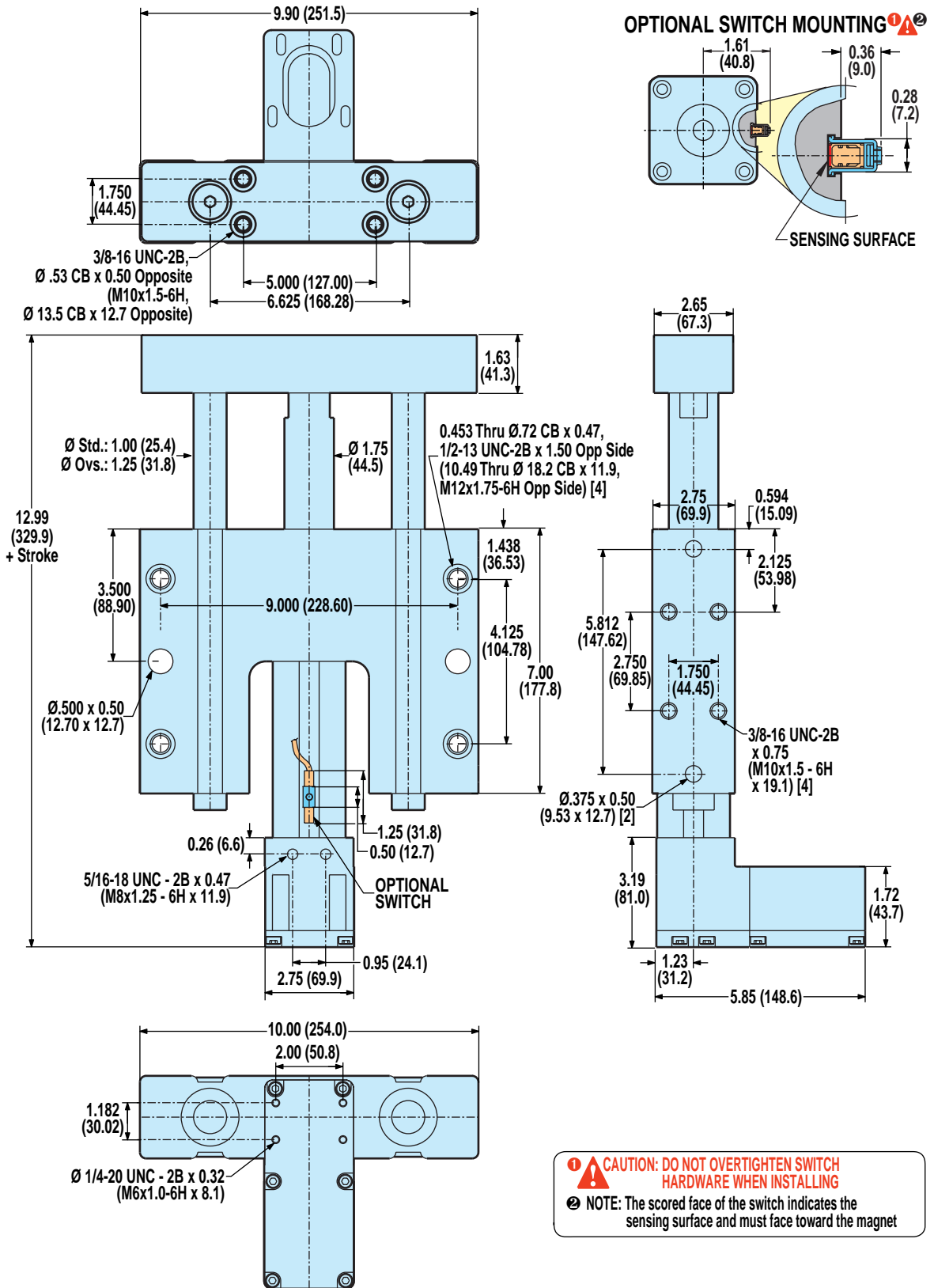

Axi-dyne® GSA/GSM32 Series

DIMENSIONS

GSA/GSM32: IN-LINE MOUNTING MOTORS AND GEARHEADS

FRAME	MOTOR	GEARHEAD	A	B	C	D	E	F
			in (mm)	in (mm)	in (mm)	in (mm)	in (mm)	in (mm)
23	MRV	NO	3.05 (77.5)	2.25 (57.2)	1.40 (35.6)	2.25 (57.2)	1.40 (35.6)	2.625 (66.7)
23	MRV, MRB	YES	2.38 (60.5)	2.25 (57.2)	1.40 (35.6)	2.25 (57.2)	1.40 (35.6)	3.875 (98.4)
23	MRS, MRB	NO	2.00 (50.8)	2.25 (57.2)	1.40 (35.6)	2.25 (57.2)	1.40 (35.6)	2.625 (66.7)
34	ALL	YES	2.38 (60.5)	3.75 (95.3)	1.63 (41.4)	3.75 (95.3)	1.63 (41.4)	3.875 (98.4)
40	MRB	NO	3.16 (80.3)	3.75 (95.3)	1.63 (41.4)	3.75 (95.3)	1.63 (41.4)	4.596 (116.7)

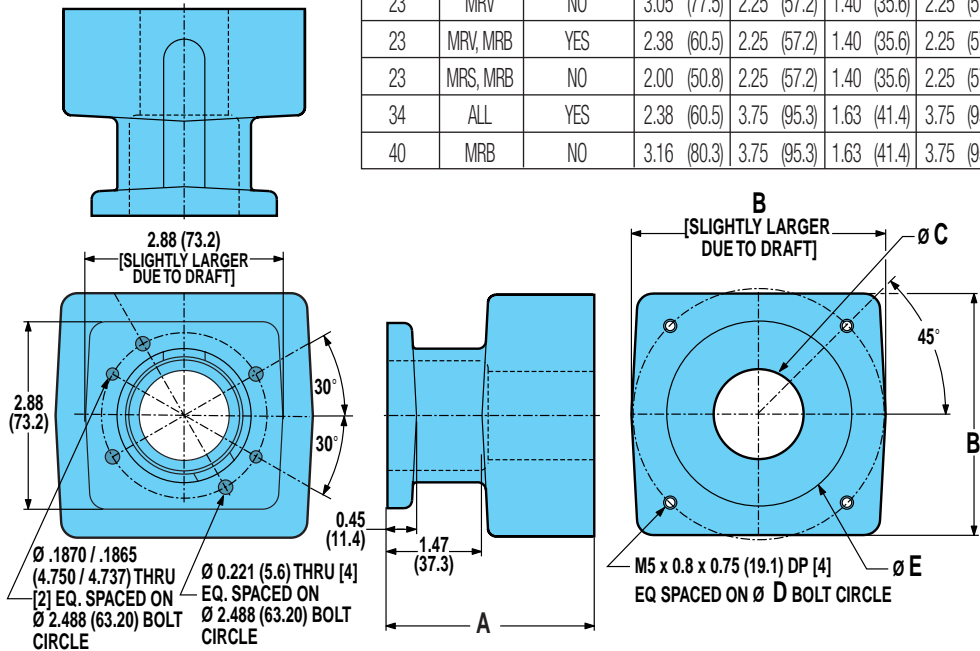

For a complete part listing of screw-drive motor and gearhead mounting kits referencing actuator/motor/coupler compatibilities, refer to document 3600-4631 available on the Literature/Part Sheets/Axidyne section of our web site at: www.tolomatic.com.

For gearhead specifications and dimensions, see page F-10.



GUIDED SCREW

GSA/GSM32 Series

- In-line motor mounting
- Reverse parallel motor mounting

GSA/GSM32: REVERSE PARALLEL MOTOR MOUNTING

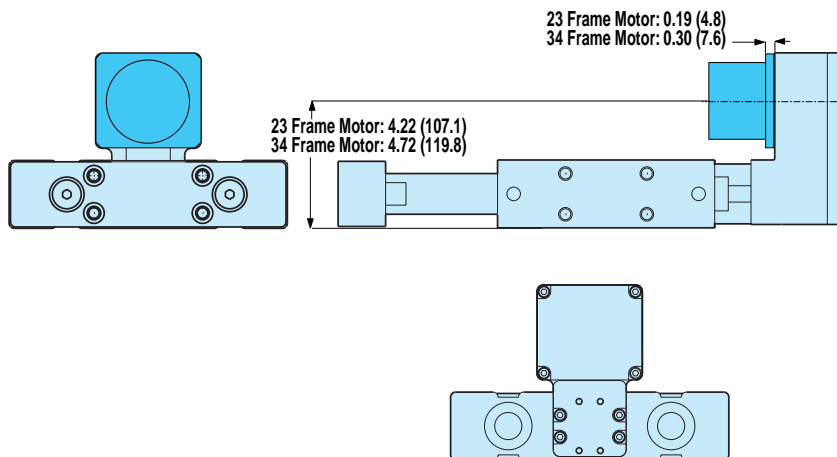

SPECIFICATIONS

MOTOR	REDUCTION INERTIA AT MOTOR SHAFT			
	1:1		2:1	
	lb-in ²	kg-m ² x 10 ⁻⁴	lb-in ²	kg-m ² x 10 ⁻⁴
BRUSHLESS MRV21, 22, 23, 24	0.467	13.650	0.144	42.256
MRV31, 32, 33	0.467	13.650	0.144	42.256
STEPPER MRS231, 232	0.467	13.650	0.144	42.256
MRS341, 343, 343	0.467	13.650	0.144	42.256
BRUSHED MRB21	0.467	13.650	0.144	42.256
MRB31, 32, 33	0.467	13.650	0.144	42.256
MRB42	0.467	13.650	0.144	42.256

REDUCTION EFFICIENCY: 0.95

Axi-dyne® Guided Screw Actuators

ORDERING

BASE MODEL SPECIFICATIONS OPTIONS SPECIFICATIONS

GSA 24 BN05 SK19 LMI CBSO CKS KT2

MODEL TYPE

GSA GSA Series English Guided Screw
GSM GSM Series Metric Guided Screw

BODY SIZE

12 0.75" Bore 24 1.5" Bore
 16 1" Bore 32 2" Bore

NUT/SCREW CONFIGURATION

SOLID NUT / PITCH (TPI) **GSA AND GSM SERIES**

SN01 12, 16, 32
SN02 12, 16, 24, 32
SN04 24,
SN05 12, 16
SN08 24
BZ10 12, 16, 24, 32

BALL NUT / PITCH (TPI) **GSA AND GSM SERIES**

BN02 32
BN05 24, 32
BN08 12, 16

STROKE LENGTH

SK _ Stroke, then enter desired stroke length in decimal inches

MODEL	MAX STROKE (in)
12 Series	18
16 Series	24
24 Series	30
32 Series	36

BASE MODEL MOUNTING OPTIONS

LMI In-line motor mounting base model
RP1 1:1 Reverse parallel mount
RP2 2:1 Reverse parallel mount*
 * Not available on 12 or 16 Series.

BEARINGS AND GUIDE RODS

LB Linear Ball Bearings*
CB Composite Bearings, Standard rods
COB Composite Bearings, Over-sized rods
CBS Composite Bearings, Stainless-steel rods
CBSO Composite Bearings, Over-sized stainless-steel rods
 * Not available with stainless-steel guide rods

STOP COLLAR OPTION

The configurator will determine the appropriate clamps to use based on the bearing and guide rod previously selected.

CK Steel Stop Collar
CKS Stainless-steel Stop Collar

SWITCHES

RM_ Reed Switch (Form A) with 5-meter lead/QD, and quantity desired
RT_ Reed Switch (Form A) with 5-meter lead, and quantity desired
BM_ Reed Switch (Form C) with 5-meter lead/QD, and quantity desired
BT_ Reed Switch (Form C) with 5-meter lead, and quantity desired
KM_ Hall-effect Sinking Switch with 5-meter lead/QD, and quantity desired
KT_ Hall-effect Sinking Switch with 5-meter lead, and quantity desired
TM_ Hall-effect Sourcing Switch with 5-meter lead/QD, and quantity desired
TT_ Hall-effect Sourcing Switch with 5-meter lead, and quantity desired
CM_ TRIAC Switch with 5-meter lead/QD, and quantity desired
CT_ TRIAC Switch with 5-meter lead, and quantity desired



Not all codes listed are compatible with all options.

Use the Tol-O-Motion™ Sizing Software to determine available options and accessories based on your application requirements.

TO ORDER MOTORS/CONTROLS/INTERFACES

 **BRUSHLESS SERVO (SEE PAGE F-33)**

 **MICROSTEPPING (SEE PAGE G-23)**

 **BRUSHED DC (SEE PAGE H-26)**

FIELD RETROFIT KITS

ITEM	GSA/GSM12 Series	GSA/GSM16 Series	GSA/GSM24 Series	GSA/GSM32 Series
Standard Stop Collar	2312-1005	2317-1005	2334-1005	2332-1005
Stainless-steel Stop Collar	2312-1056	2317-1056	2324-1056	2332-1056
Oversized Stop Collar	2317-1005	2324-1005	2332-1005	2348-1005
Oversized Stainless-steel Stop Collar	2317-1056	2324-1056	2332-1056	2348-1056



Kits contain one collar and appropriate fasteners.



GUIDED SCREW

GSA/GSM Series

- Ordering

Axi*dyne*[®] Brushless Servo System

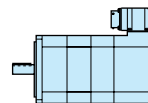

BRUSHLESS

- **MRV BRUSHLESS SERVO MOTORS**
- **AXIOM[®] DV SERVO DRIVE**
- **AXIOM[®] PV SERVO CONTROLLER/DRIVE**
- **SSC CONTROLLER**
- **JS JOYSTICK INTERFACE**
- **SIT HAND-HELD INTERFACE**

Axi dyne® Brushless Servo System

OVERVIEW

APPLICATION BENEFITS

- Extremely smooth and quiet operation
- Good for high torques [up to 45 in-lbs. (5.08 N-m) continuous, 140 in-lbs. (15.82 N-m) peak]
- Good for high speeds, up to 6,000 RPM
- High resolution, 4,000 counts per revolution
- Provide torque control
- Good for short, repetitive moves
- Maintenance free with no moving contacts

MOTOR



MRV - Brushless Servo Motors

- Rugged, with large shafts and bearings, IP65
- Convenient MS connectors
- Common flanges (NEMA 17, 23, 34 and 56)
- Integral temperature sensor and 1000 line encoder
- Gearhead reduction available in gear ratios of 5.5:1 and 10:1 when selected with Tol-O-Matic screw-drive actuators

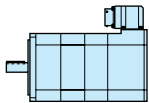

BRUSHLESS

Overview

DRIVE



Axiom DV - Servo Drive

- Designed to drive MRV motors
- Peak current ratings of 10A, 20A and 30A
- State-of-the-art vector commutation and current control for efficient high-bandwidth servo performance
- Simple Windows®-based software for set-up and installation

DRIVE - CONTROLLER



Axiom® PV Controller/Drive:

- Combines into one unit:
 - PLC: with real-time scan, 175 rung ladder logic
 - Motion Controller: with 1.5 axis, event triggering, motion pause and resume, point & click editor
 - Axiom drive: with all features listed above

- Includes Tol-O-Motion™ Axiom Motion Control Software and intuitive point and click sequential program and PLC ladder logic editors

CONTROLLER



SSC Controller:

- Performs any motion task including jogging, point-to-point positioning, linear and circular interpolation, electronic gearing, camming and contouring
- Multitasking feature permits simultaneous execution of four independent applications programs
- Tol-O-Motion SSC Motion Control Software allows setup & programming with easy-to-use Windows® interface
- Up to 4 axes per unit - up to 4 units can be daisy-chained
- 4M non-volatile EEPROM memory for executing custom application programs - permits stand-alone operation
- Relative and absolute positioning with more than ± 2,000,000,000 counts per move
- Inputs: opto-isolated dedicated for home, abort, forward and reverse limits, 8 uncommitted; 7 analog inputs
- Outputs: 8 programmable

INTERFACES

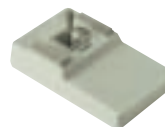

JS - Joystick

- Use with SSC joystick teach mode



SIT - Hand-held interface

- 45 key - keypad, LCD display
- for use with SSC

Host compatible PC

Axi dyne® MRV Brushless Servo Motors

FEATURES AND SPECIFICATIONS



COMPATIBILITY:
SYSTEM: BRUSHLESS

MOTORS: MRV

DRIVE: AXIOM DV
AXIOM PV

CONTROLLER: SSC
AXIOM PV

INTERFACE: JS
SIT

MRV Brushless Servo Motors

Tol-O-Matic's MRV series brushless servo motors provide a wide range of rated torques and speeds for applications requiring long life under continuous, difficult environment operation. These motors are designed for maximum power density. The MRV series motor come with an internally mounted 1000 line encoder.

FEATURES

- Rugged industrial enclosures
- Large shafts and bearings for longer life with high radial and axial loads
- Dual convenient MS connectors to simplify motor termination and provide excellent noise immunity
- Common industrial mechanical flanges (NEMA 17, 23, 34, 56)
- Integral 1000 line TTL encoder with differential line driver outputs
- Ideally suited for use with Axiom DV drives (motor parameters are stored with drive) – torque/speed curves shown on the following pages reflect MRV motors with Axiom drive performance.
- Internal thermal protection
- IP65* rated (except MRV11)

*Totally protected against dust and low pressure jets of water.

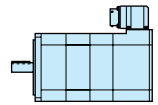

BRUSHLESS

MRV Motors

- Features
- Specifications

SPECIFICATIONS

Model	KE (1)	KT (2)	Resistance (3)		Rotor Inertia		Thermal Resistance	Cont. Stall Torque		Peak Stall Torque		Max. Speed	Inductance (4)	Weight	
	Volts/1000RPM	lb-in/amp	N-m/amp	Ohms	lb-in ²	kg-m ² x 10 ⁶	°C/W	lb-in	N-m	lb-in	N-m	RPM	mH	lbs	kgs
MRV11	6.06	0.893	0.100	2.24	0.020	5.72	—	2.50	0.28	12.50	1.41	5,000	1.63	1.16	0.53
MRV21	8.80	1.290	0.144	2.22	0.053	15.58	1.80	3.75	0.42	11.31	1.28	6,000	1.81	2.20	1.00
MRV22	14.50	2.120	0.237	2.04	0.099	28.90	1.30	7.50	0.85	22.50	2.54	6,000	2.10	3.10	1.40
MRV23	21.80	3.190	0.357	2.73	0.143	41.70	1.23	11.25	1.27	33.81	3.82	6,000	2.95	4.00	1.80
MRV24	29.00	4.250	0.476	3.36	0.193	56.33	1.16	15.63	1.77	46.88	5.30	6,000	3.81	5.00	2.30
MRV31	14.80	2.170	0.243	1.10	0.386	112.85	0.72	17.00	1.92	85.00	9.60	6,000	2.60	8.00	3.60
MRV32	22.20	3.250	0.364	0.80	0.694	203.02	0.58	30.00	3.39	150.00	16.90	6,000	2.50	11.50	5.20
MRV33	25.90	3.790	0.424	0.60	1.006	294.47	0.56	44.00	4.97	220.00	24.90	6,000	2.10	14.00	6.35
MRV51	48.90	7.150	0.801	0.54	2.531	740.75	0.72	80.00	9.04	240.00	27.10	3,000	3.06	26.00	11.80

ALL RATINGS TYPICAL AND AT 77°F (25°C) UNLESS OTHERWISE NOTED. WINDING TEMPERATURE AT 257°F (125°C).

(1) L-L, RMS (±10%) (2) PER PHASE, RMS (±10%) (3) L-L DC RESISTANCE (±10%) (4) L-L (±15%)

Axi dyne[®] MRV Brushless Servo Motors

PERFORMANCE DATA WITH AXIOM[®] DV/PV DRIVES

MRV11Y • DV/PV10 DRIVE • THREE-PHASE

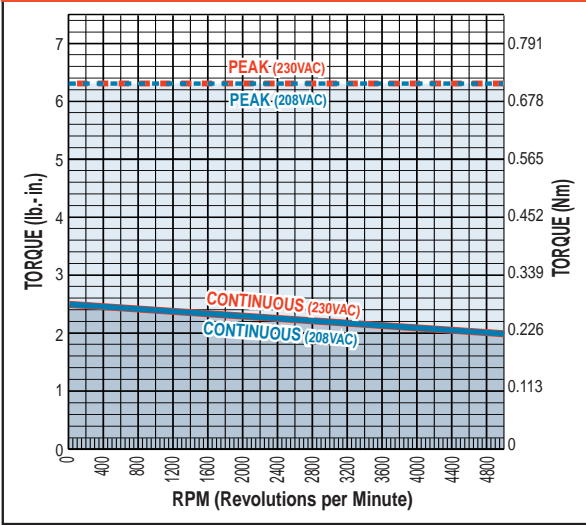

MRV11Y • DV/PV10 DRIVE • SINGLE-PHASE

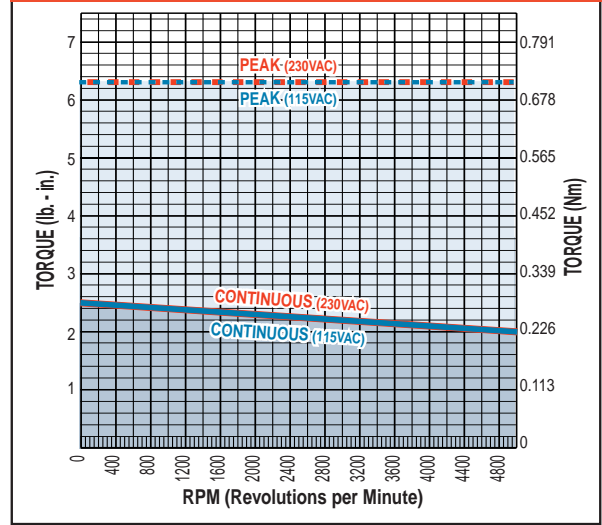

MRV21Y • DV/PV10 DRIVE • THREE-PHASE

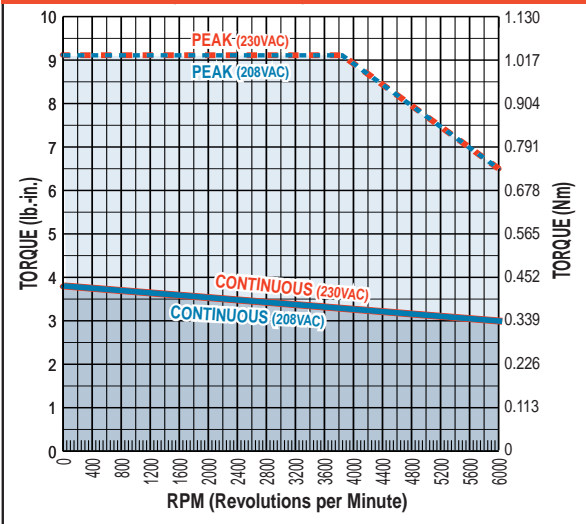

MRV21Y • DV/PV10 DRIVE • SINGLE-PHASE

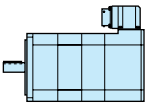
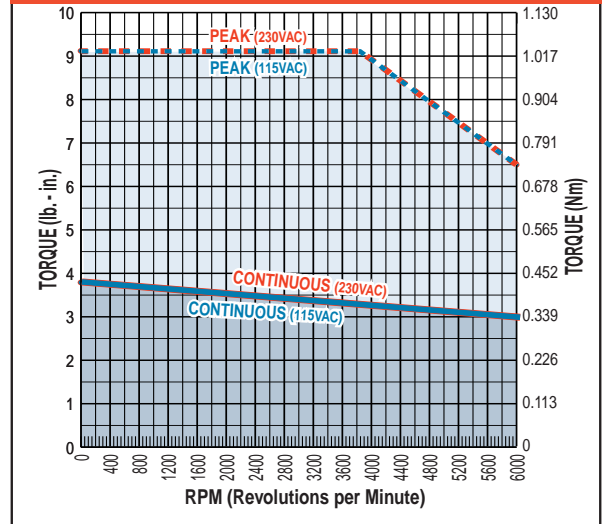

BRUSHLESS

MRV Motors
• Performance data

MRV22Y • DV/PV10 DRIVE • THREE-PHASE

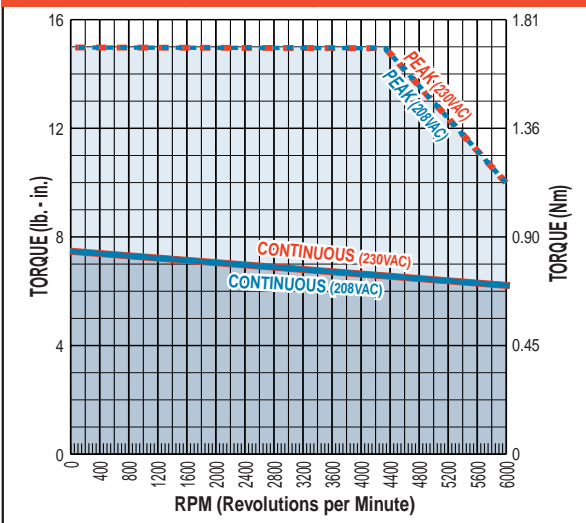

MRV22Y • DV/PV10 DRIVE • SINGLE-PHASE

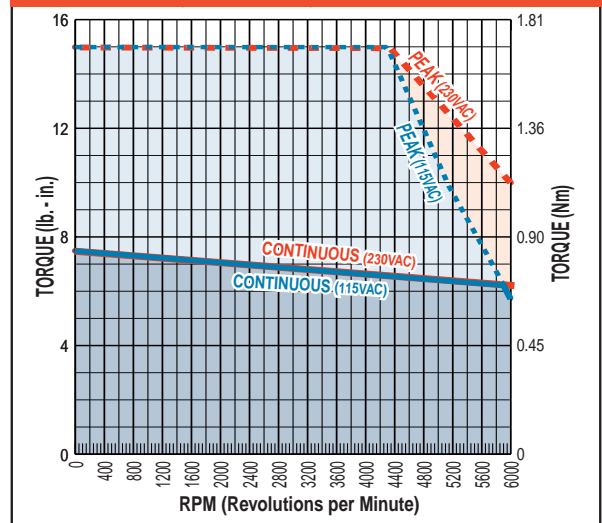

Axi-dyne® MRV Brushless Servo Motors

PERFORMANCE DATA WITH AXIOM® DVIPV DRIVES

MRV23Y • DV/PV10 DRIVE • THREE-PHASE

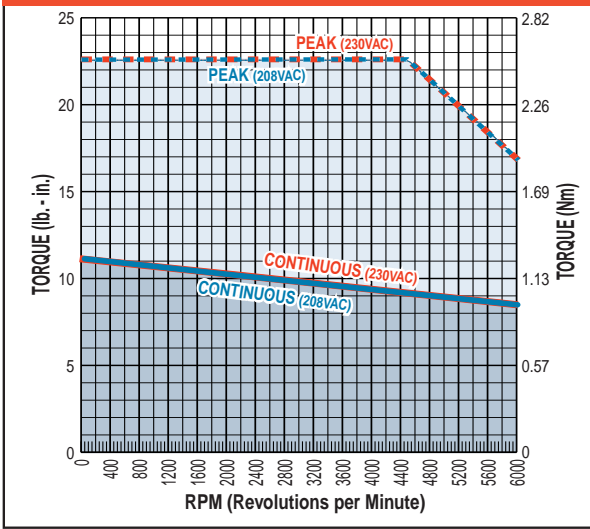

MRV23Y • DV/PV10 DRIVE • SINGLE-PHASE

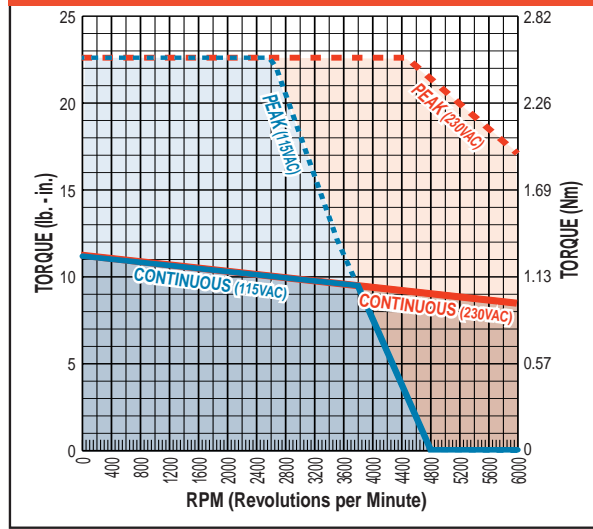

MRV24Y • DV/PV10 DRIVE • THREE-PHASE

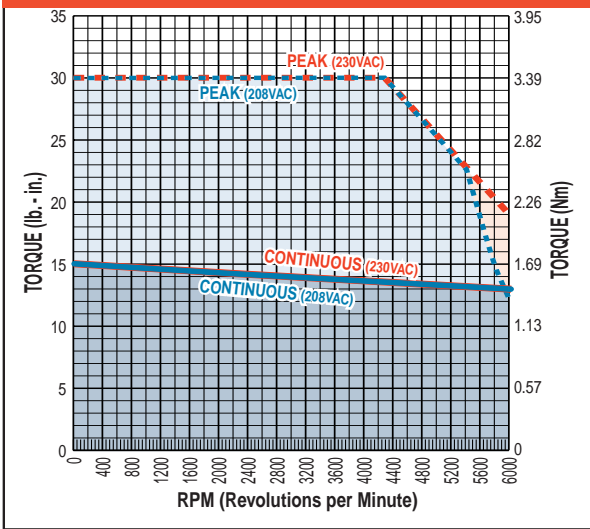

MRV24Y • DV/PV10 DRIVE • SINGLE-PHASE

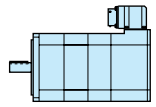
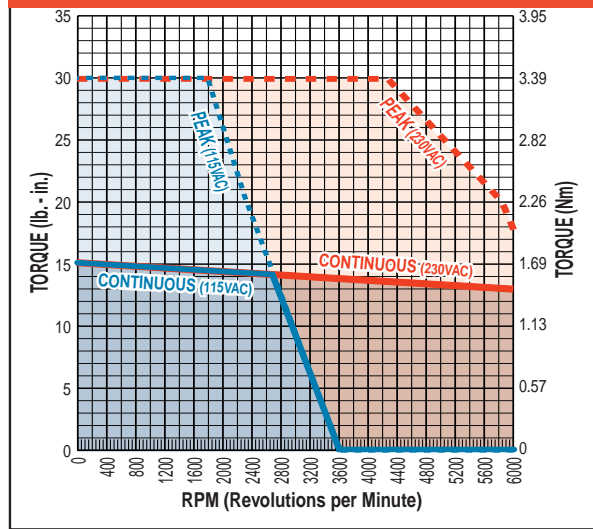

BRUSHLESS

MRV Motors
• Performance data

MRV31Y • DV/PV10 DRIVE • THREE-PHASE

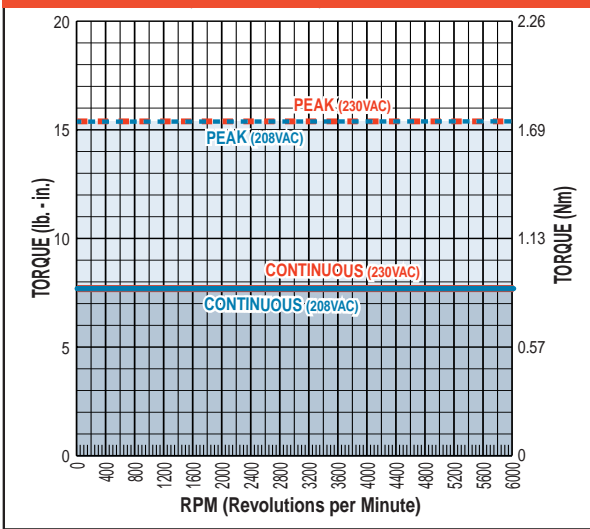

MRV31Y • DV/PV10 DRIVE • SINGLE-PHASE

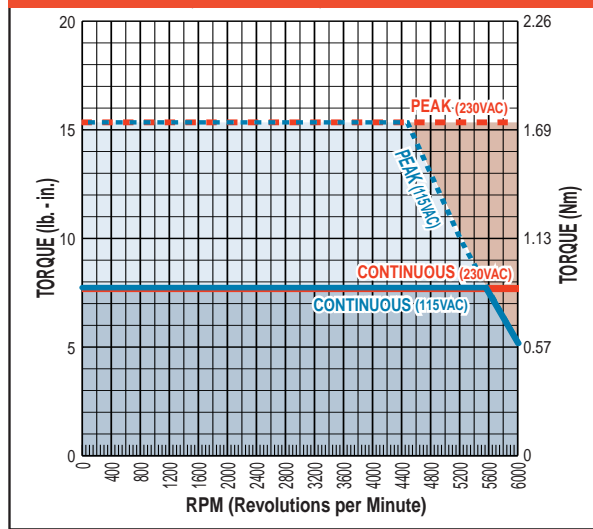

Axi dyne[®] MRV Brushless Servo Motors

PERFORMANCE DATA WITH AXIOM[®] DV/VPV DRIVES

MRV31Z • DV/VPV20 DRIVE • THREE-PHASE

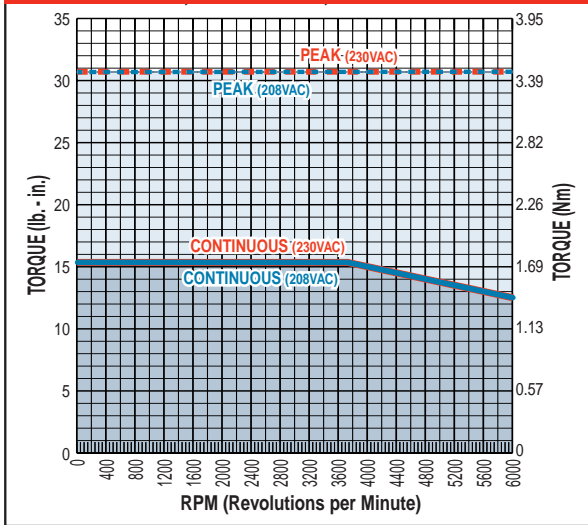

MRV31Z • DV/VPV20 DRIVE • SINGLE-PHASE

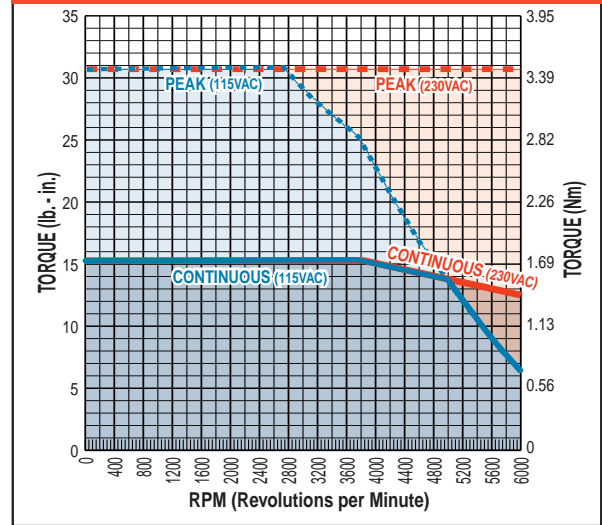

MRV32Y • DV/VPV20 DRIVE • THREE-PHASE

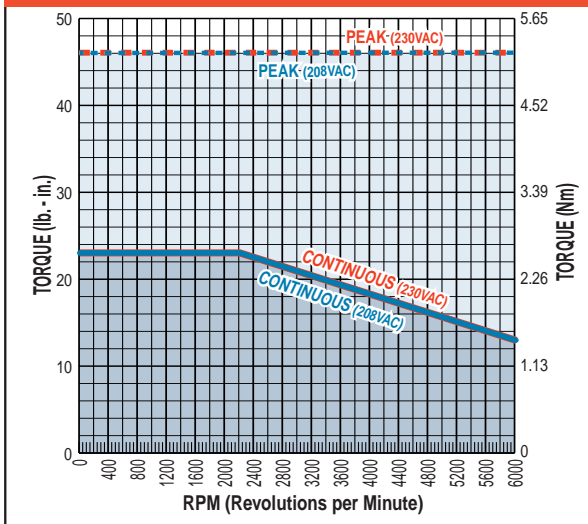

MRV32Y • DV/VPV20 DRIVE • SINGLE-PHASE

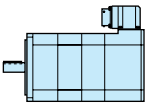
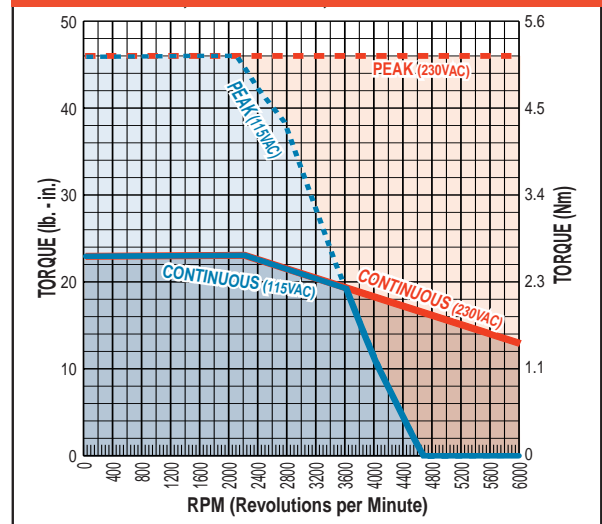

BRUSHLESS

MRV Motors
• Performance data

MRV32Z • DV/VPV30 DRIVE • THREE-PHASE

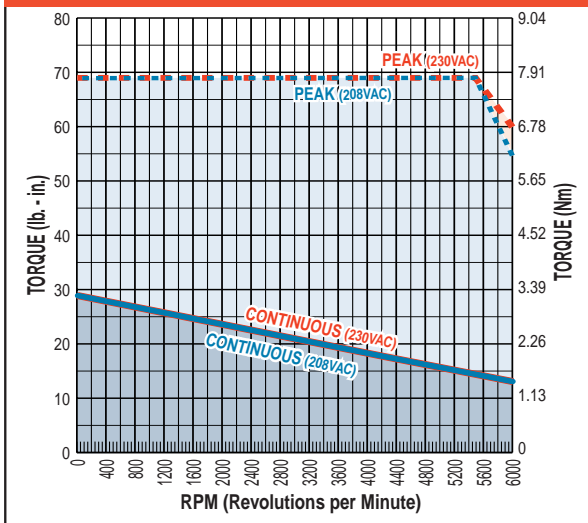

MRV32Z • DV/VPV30 DRIVE • SINGLE-PHASE

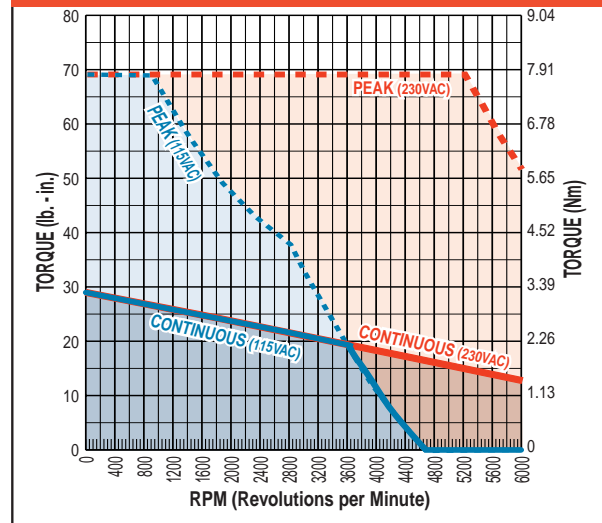



MRV Brushless Servo Motors

PERFORMANCE DATA WITH AXIOM® DVIPV DRIVES

MRV33Y • DV/PV20 DRIVE • THREE-PHASE

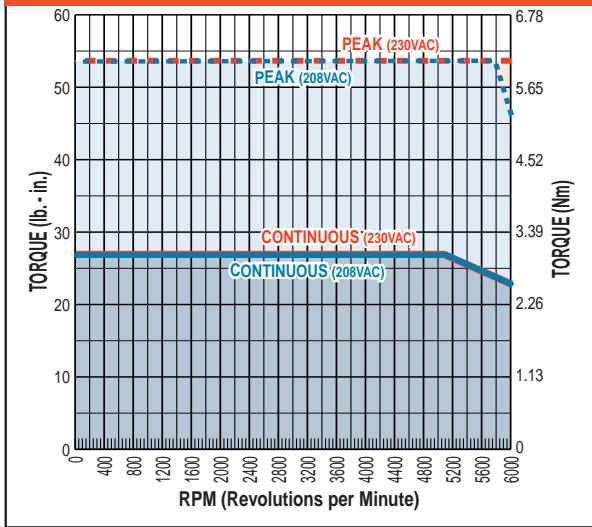

MRV33Y • DV/PV20 DRIVE • SINGLE-PHASE

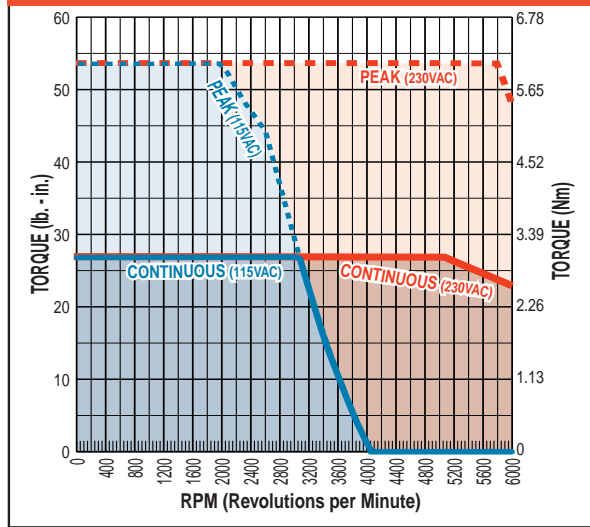

MRV33Z • DV/PV30 DRIVE • THREE-PHASE

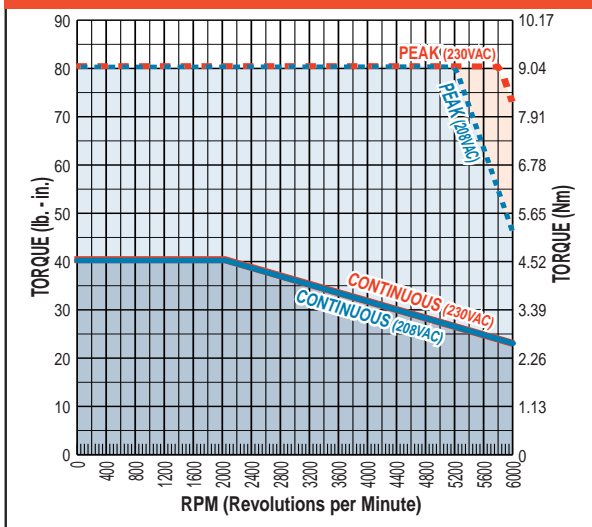

MRV33Z • DV/PV30 DRIVE • SINGLE-PHASE

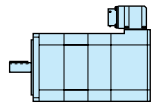
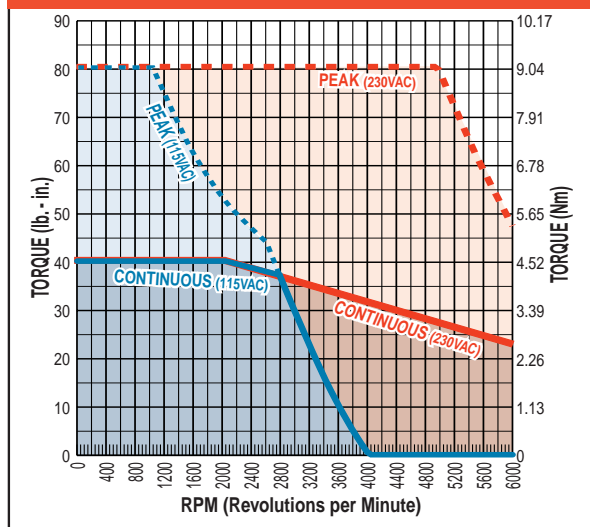

BRUSHLESS

MRV Motors

- Performance data

MRV51Y • DV/PV30 DRIVE • THREE-PHASE

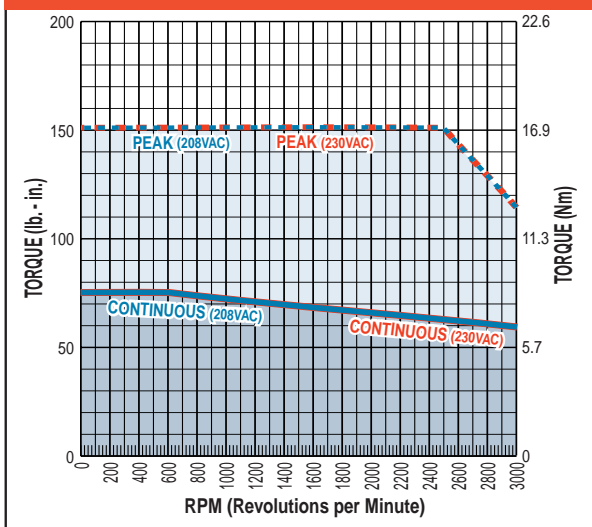

MRV51Y • DV/PV30 DRIVE • SINGLE-PHASE

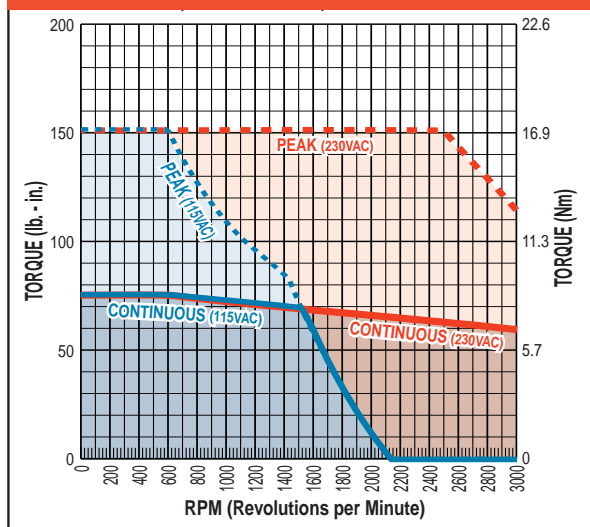

Axi-dyne[®] MRV Brushless Servo Motors

DIMENSIONS

MRV I

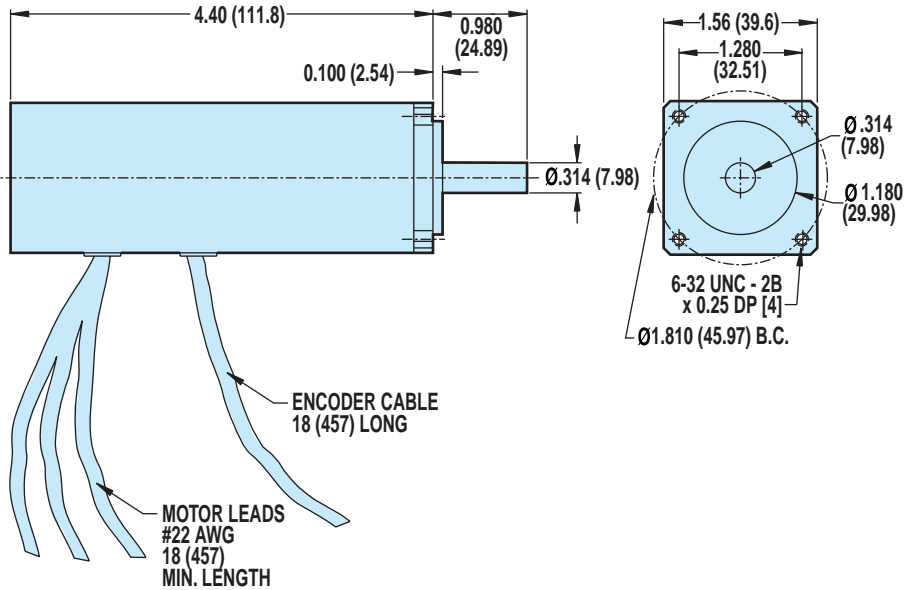

MRV21, 22, 23, 24

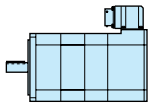

BRUSHLESS

MRV Motors
• Dimensions

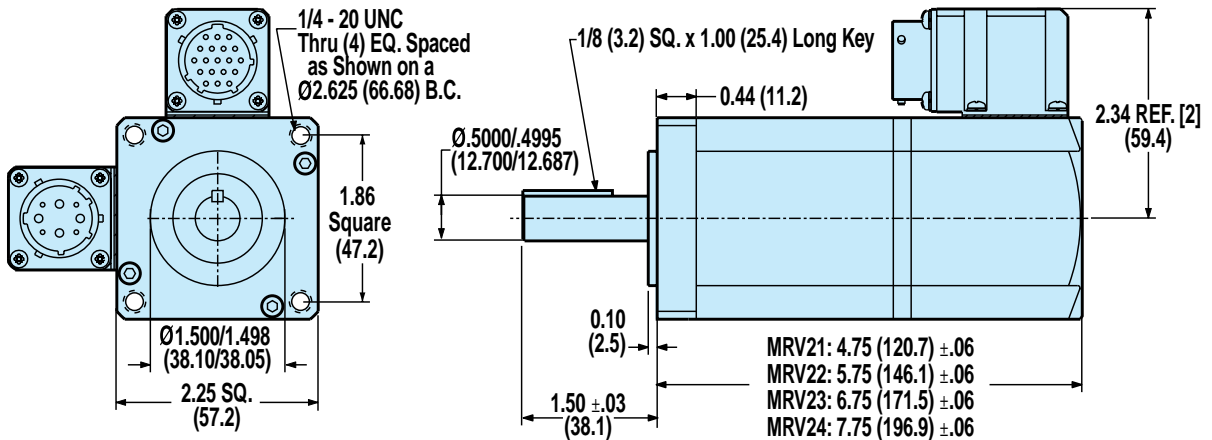

Unless otherwise noted, all dimensions shown are in inches (Dimensions in parenthesis are in millimeters)

Axi dyne® MRV Brushless Servo Motors

DIMENSIONS

MRV31, 32, 33

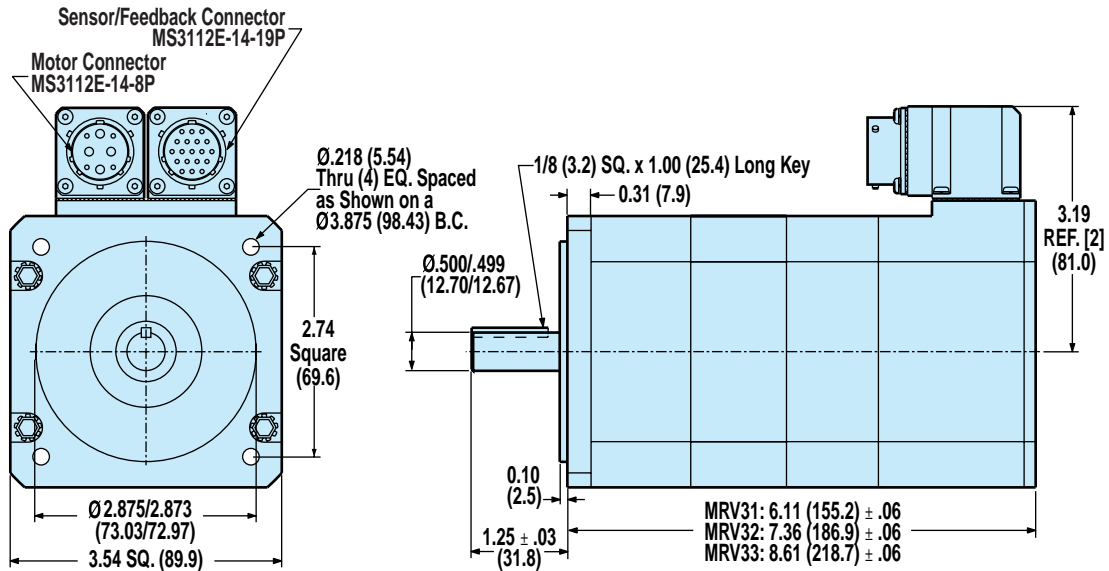

MRV51

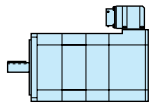
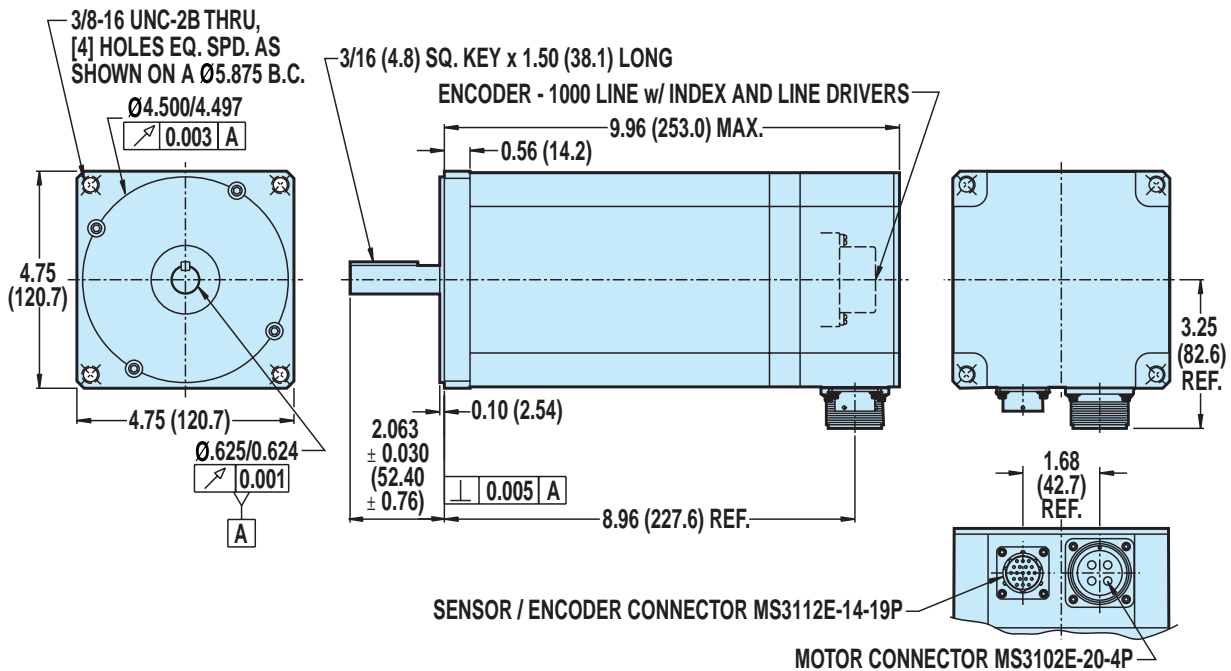

BRUSHLESS

MRV Motors
• Dimensions

Axi-dyne® Gearhead Reduction

SPECIFICATIONS AND DIMENSIONS

COMPATIBILITY:

SYSTEM: BRUSHLESS

MOTORS: MRV

ACTUATORS: ALL
TOL-O-MATIC
SCREW
DRIVES

COMPATIBILITY:

SYSTEM: STEPPER

MOTORS: MRS

ACTUATORS: ALL
TOL-O-MATIC
SCREW
DRIVES

COMPATIBILITY:

SYSTEM: BRUSHED DC

MOTORS: MRB

ACTUATORS: ALL
TOL-O-MATIC
SCREW
DRIVES



⚠ * Reflected inertia is inertia at motor side of gearhead.
§ Only available on RSA64 LMI

For a complete part listing of screw-drive motor and gearhead mounting kits referencing actuator/motor/coupler compatibilities, refer to document 3600-4631 available on the Literature/Axidyne/Part Sheet section of our web site at: www.tolomatic.com.

For those applications requiring reduction for inertia matching or higher torque at lower speeds, Tol-O-Matic offers high efficiency, single stage, true planetary gearheads. Gear ratios of 5.5:1 and 10:1 are available and are compatible with 23- and 34-frame MRV Brushless Servo, MRS Microstepping and Brushed DC motors.

SPECIFICATIONS

Efficiency:	85%
Backlash:	less than 10 arc minutes
Max. Input Speed:	5000 RPM

CONFIG NO.	PART NO.	FRAME SIZE	GEAR RATIO	REFLECTED INERTIA*		INPUT SHAFT DIA. (in)	WEIGHT	
				lb-in ²	kg-m ²		lbs	kgs
GHJ20	3600-6151	23	5.5 : 1	0.0213	6.22	0.500	2.00	0.91
GHJ21	3600-6152	23	10 : 1	0.0181	5.30	0.500	1.98	0.90
GHJ30	3600-6154	34	5.5 : 1	0.1131	33.09	0.500	4.60	2.09
GHJ31	3600-6155	34	10 : 1	0.0888	25.96	0.500	4.78	2.17
GHJ32 [§]	3600-6156	34	10 : 1	0.0888	25.96	0.500	4.81	2.18

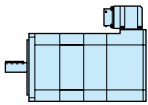

BRUSHLESS

Gearhead Reduction

- Specifications
- Dimensions

23 FRAME GEARHEAD

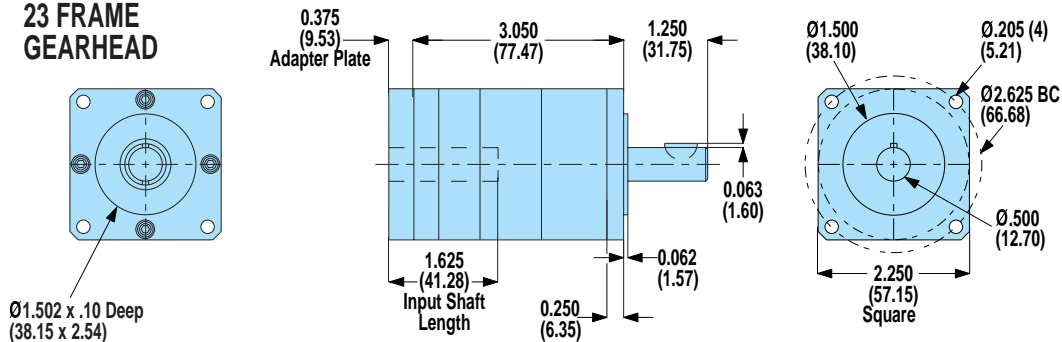

34 FRAME GEARHEAD

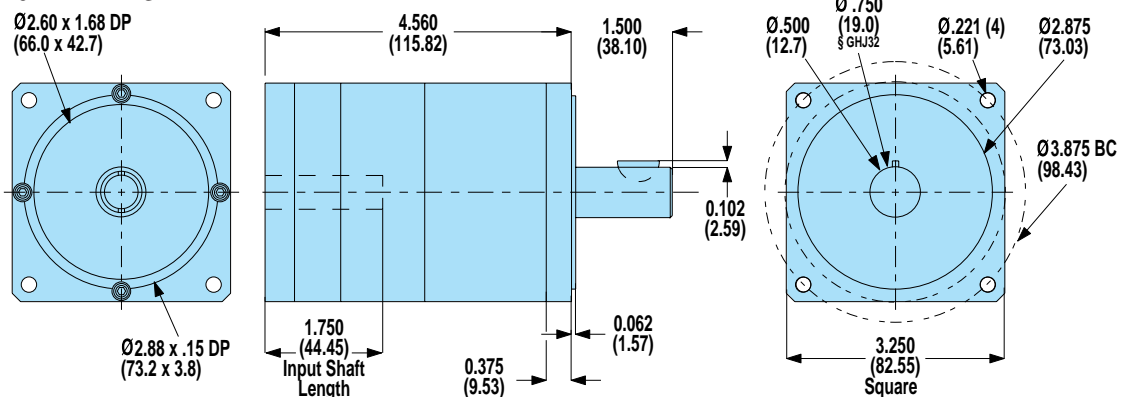

Unless otherwise noted, all dimensions shown are in inches (Dimensions in parenthesis are in millimeters)

Axi dyne® AXIOM® DV Brushless Servo Drive

FEATURES

COMPATIBILITY:
SYSTEM: BRUSHLESS
MOTORS: MRV
DRIVE: AXIOM DV

CONTROLLER: SSC
INTERFACE: JS
SIT



• CONSIDER THE AXIOM PV FOR ALL OF THE FEATURES OF THE AXIOM DV, PLUS AN INTEGRAL CONTROLLER, & PLC ELIMINATING THE NEED FOR THE SSC CONTROLLER

The Axiom series of brushless and brushed servo drives combine high-speed accuracy with user friendly set-up and diagnostics. The Axiom DV series is a state-of-the-art DSP controlled digital vector commutated drive for a full range of brushless servo motors. DV series drives are available in 10, 20 and 30 Amp peak ratings (3 sec). All come with convenient pluggable screw terminal connectors and offer fast, easy set-up and installation for use in a wide variety of applications.

AXIOM® DV DRIVE FEATURES

- Space vector commutation provides better bus voltage utilization than traditional sine drives for improved speed/torque curves
- Flux vector current control provides more accurate high bandwidth control of torque producing current for better efficiency and more torque over the full speed range than with traditional sine drives
- Drives MRV series brushless servo motors
- Autophasing eliminates the need for Hall sensors in motors
- Pluggable screw terminal connectors eliminate the need for special connectors and secondary breakout terminal strips
- 115/208-230Vac input, single or 3-phase
- Short circuit, over current and over voltage protection prevents drive damage
- 25W or 50W internal regeneration
- External regeneration connections
- Analog torque and velocity command (\pm) 10V or step and direction (CW/CCW) position control
- Feedback from differential A+B and index channel optical encoder (5V)
- Maximum line count of 500,000/motor commutation cycle
- CW/CCW travel limit inputs
- Drive enable input
- Fault, enabled, and in-position outputs
- 3A brake relay
- 3 second peak ratings

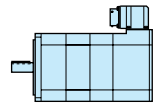

BRUSHLESS

Axiom DV Drive

• Features

Axi dyne® AXIOM® DV Brushless Servo Drive

SPECIFICATIONS

AXIOM® DV SPECIFICATIONS

SPECIFICATIONS	Axiom™ DV and DB Series Drives		
	DV10	DV20	DV30
Power			
Continuous Current Rating:	5 Amps	10 Amps	15 Amps
Peak Current Rating (3 sec):	10 Amps	20 Amps	30 Amps
Max Input Current (single phase):	12.5 Amps	25 Amps	37.5 Amps
Input Voltage (single/3-phase):	95Vac -130Vac / 190Vac - 250Vac (voltage range is switch selectable)		
Input Frequency:	47Hz - 63Hz		
Command Sources			
Analog Torque/Velocity Input:	± 10V, 16.4K ohm impedance		
Step and Direction or Step CW/Step CCW:	1 MHz maximum, 5V differential or single ended drivers		
Serial Communication Port			
Type:	RS232		
Baud Rate:	19,200 baud		
Control Loops			
Type:	All digital		
Loop Modes:	Torque, Velocity and Position Control		
Torque Update Rate:	10KHz		
Velocity Update Rate:	5KHz		
Position Update Rate:	2.5KHz		
Inputs and Outputs			
Dedicated Optically Isolated Inputs:	5Vdc - 25Vdc, 2.7ma - 15ma ENABLE, CW LIMIT and CCW LIMIT. Can be configured to source or sink current.		
Dedicated Optically Isolated Outputs:	3 optically isolated, 25Vdc max., 50ma max. IN POSITION, ENABLED and FAULT. Can be configured to source or sink current.		
1 Dedicated Brake Relay Output:	N.O. contact, 24Vdc, 115/230Vac, 3A max.		
Motor Feedback:	Incremental encoder, 5Vdc, differential 4Mhz max., A/B/I channels 250 line min. with a 4 pole motor 125 line min. with a 2 pole motor		
Encoder Output:	Differential, 5Vdc, A/B/I channels		
Connectors			
Serial:	9 pin D-Sub.		
Control and Feedback:	15 pin D-Sub.		
Power, Motor, Brake Relay, Regen:	Screw terminal block		
All Others:	Pluggable screw terminal blocks		
Approvals	UL, CUL, CE		
Environmental			
Storage Temperature:	-40°C to 70°C		
Operating Temperature:	0°C to 50°C		
Humidity:	5% to 95%, non-condensing		
Weight:	DV10	DV20	DV30
	8 lbs	12 lbs	12 lbs
	(3.7 Kg)	(5.5 Kg)	(5.5 Kg)

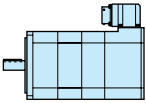

BRUSHLESS

Axiom DV Drive

- Specifications

Axi dyne® Axiom® DV Brushless Servo Drive

CONNECTORS

AXIOM® DV CONNECTORS

TB1 - BRAKE/REGEN

1 - Brake	4 - External Regen
2 - Brake	5 - Internal Regen
3 - Regen Common	

TB2 - MOTOR

1 - Motor R	3 - Motor T
2 - Motor S	4 - Motor Ground

TB3 - AC POWER

1 - L3	3 - L1
2 - L2	4 - Ground

J3 - OUTPUTS

1 - In Position +	4 - Enabled Out -
2 - In Position -	5 - Fault Out +
3 - Enabled Out +	6 - Fault Out -

J4 - INPUTS

1 - CW Limit	6 - Step/Step CW +
2 - CCW Limit	7 - Step/Step CW -
3 - Limit Common	8 - Direction/Step CCW +
4 - Enable +	9 - Direction/Step CCW -
5 - Enable -	

J6 - ANALOG INPUT COMMAND

1 - Analog Common	3 - Analog -
2 - Analog +	4 - Shield

J7 - MOTOR ENCODER

1 - Encoder +5V	6 - I+
2 - A+	7 - I-
3 - A-	8 - Common/Shield
4 - B+	9 - Motor Temp
5 - B-	

PI - BUFFERED ENCODER OUTPUT

1 - Reserved	8 - Common
2 - Reserved	9 - Encoder Out A+
3 - Reserved	10 - Encoder Out A-
4 - Reserved	11 - Encoder Out B+
5 - Reserved	12 - Encoder Out B-
6 - Reserved	13 - Encoder Out I+
7 - Reserved	14 - Encoder Out I-

P2 - COMMUNICATIONS

1 - Reserved	6 - Reserved
2 - RS-232 TX	7 - Reserved
3 - RS-232 RX	8 - Reserved
4 - Reserved	9 - +5Vdc (30ma MAX.)
5 - Common	

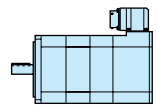

BRUSHLESS

Axiom DV Drive
• Connectors

Axi-dyne® Axiom® DV Brushless Servo Drive

SET-UP / CONFIGURATION

Axiom® Windows®-based PC setup software with a “control-panel” approach, makes it easy to get up and running fast. All set-up and configuration functions are performed using two main control-panel screens. Simple mouse-click commands automatically configure the control functions, eliminating layers of screens and menus. This approach also allows more relevant diagnostic information to be displayed simultaneously. All control screens include a command menu at the upper left to permit convenient selection of high-level functions and options.

A main menu is provided which allows selection of the main control panel functions, active comm port, etc. Tutorial selections are provided which emulate the main control-panel functions in an off-line manner and provide “help” text and function definitions/ descriptions so that users can actively familiarize themselves with the software without actually connecting a drive.

The software communicates with the drive using a standard RS-232 connection operating at 19,200 baud, using either comm port 1 or 2 of the PC. It can be installed and executed from any PC running Windows 95, 98, NT, 2000 or XP.

SET-UP CONFIGURATION

Drive operating mode and other options can all be selected/enabled from this screen. All set-up parameters can be uploaded and downloaded with a single click of the mouse. The parameter set can be saved to or retrieved from a disk file. Once downloaded to the drive, all parameters are stored in non-volatile EEPROM memory.

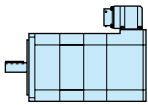

BRUSHLESS

Axiom DV Drive
• Set-up / configuration

The screenshot shows the 'Setup and Configuration' window with the following sections:

- Commands, Set-up and Configuration Mode:** Select Drive, Select Standard Motor, Retrieve Parm's from Disk File, Upload Parm's from Drive, Download Parm's to Drive, Save Parm's to Disk File, Exit Drive Set-Up Mode (EXIT).
- Drive Model Selection / Setup:** Drive Model #: DV10, Drive Continuous Current: 5, Drive Peak Current: 10.0 amps, Clockwise Travel Limit: N-Open, Counter-CW Travel Limit: N-Open, Drive Enabled Output: N-Open, Drive Faulted Output: N-Open, In-Position Output: N-Open.
- Motor Model Selection / Setup:** Motor Model #: MFRV21, Motor Cont. Stall Torque: 3.75 in-lb, Motor Peak Torque: 11.3 in-lb, Ke, Volts L-L ms/krpm: 8.8, Kt, in-lb/Amp ph ms: 1.29, # of Magnetic Poles: 4, Encoder pulses/rev (x4): 4000, Maximum Speed, rpm: 6000.
- Drive Operating Mode Selection:** Torque Mode Analog Input, **Velocity Mode Analog Input** (selected), Step/Dir Input Position Mode, CW/CCW Input Position Mode.
- Gains and Offsets:** Ani Offset = 0 mV, VDbain = 0, Ani In SF = 1.00, VUgain = 0, VPgain = 18, AUgain = 3, Vlgain = 55.
- Phasing Configuration:** Phasing Position Increment (degrees): 0, Phasing Torque (% of drive peak): 60.

Annotations with red arrows:

- DRIVE MODEL # DISPLAY AND PARAMETER CONFIGURATION.** (Points to Drive Model # DV10)
- DRIVE MODE SELECTION.** (Points to Velocity Mode Analog Input)
- DISPLAY OF TUNING AND OFFSET PARAMETERS FOR REFERENCE PURPOSES (SET IN TUNING CONTROL SCREEN).** (Points to Gains and Offsets section)
- MOTOR SELECTION AND CONFIGURATION.** (Points to Motor Model Selection / Setup section)
- CONFIGURATION/SET-UP FOR AUTO-PHASING FUNCTION INCLUDING INDEX PULSE MONITORING FOR COMMUTATION ACCURACY AND FASTER DETECTION OF FEEDBACK ERRORS.** (Points to Phasing Configuration section)

Axi-dyne® Axiom® DV Brushless Servo Drive

SET-UP / CONFIGURATION

TUNING AND DIAGNOSTICS

Use the 4-channel oscilloscope display for analysis of motion response when tuning and diagnosing. Scaling and format of the displayed traces can be easily modified. Values can be read directly off the traces at any point. Continuously updated bar graph displays allow important data to be viewed while motion is occurring. These displays are configured automatically based on drive operating mode they include peak detection functions and numeric displays. A status section of this control screen displays the current state of I/O and fault information.

Selecting "Drive-Tuning" from the command menu activates and displays the control functions for manual and automatic drive tuning. Use these controls to set-up and start actuation of an appropriate unit-step motion command and then enable automatic tuning parameter adjustment. Manual adjustments to tuning parameters can be easily accomplished.

The oscilloscope functions are used in conjunction with tuning, ensuring desired response goals are achieved. All tuning parameters are updated and activated immediately in the drive when modified (and also stored in EEPROM memory).

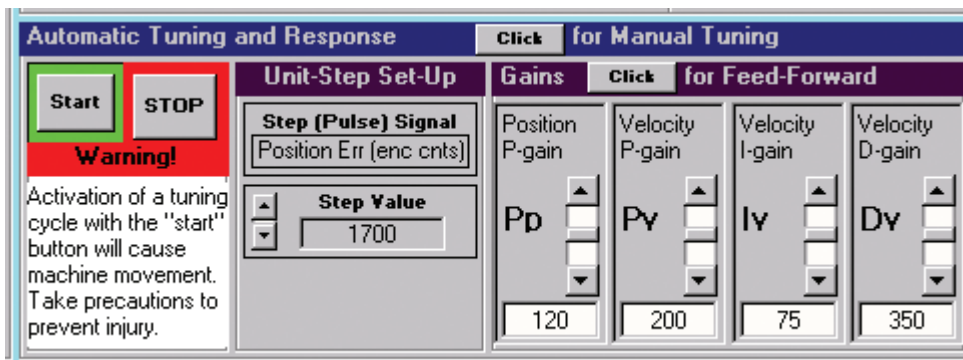

TUNING CONTROLS ALLOW USER CONFIGURABLE UNIT-STEP ACTUATION. AUTOMATIC AND MANUAL TUNING FUNCTIONS ARE PROVIDED. OPTIONAL VALUES FOR FEED FORWARD GAINS AND ANALOG OFFSETS CAN ALSO BE ENTERED.

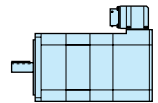

4-CHANNEL OSCILLOSCOPE DISPLAY FOR SET-UP/TUNING AND SUBSEQUENT DIAGNOSIS. FLEXIBLE DISPLAY CONFIGURATION AND SLIDING VALUE INDICATOR, MAKE ANALYSIS QUICK AND EASY. INCLUDES USER CONTROLLED TRIGGER FUNCTIONS.

BRUSHLESS

Axiom DV Drive
• Set-up / configuration

ALL SOFTWARE SCREENS INCLUDE SEPARATE MENUS OF HIGH-LEVEL FUNCTIONS IN THE UPPER LEFT CORNER TO FACILITATE QUICK TRANSITIONS BETWEEN SCREENS AND FUNCTIONS.

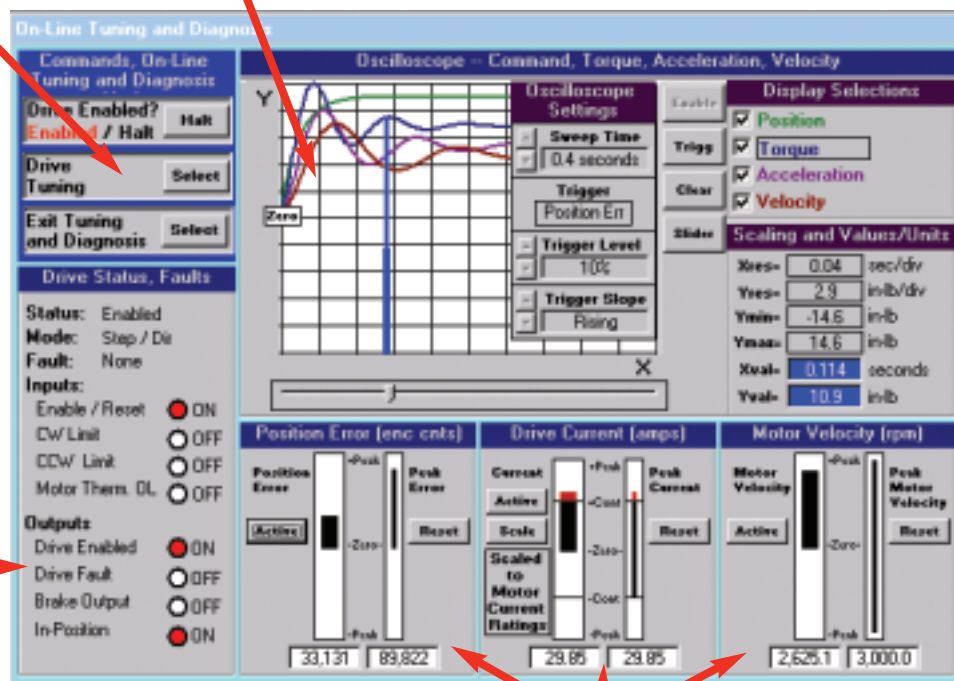

CONTINUOUS DISPLAY OF CRITICAL DRIVE STATUS INFORMATION AS WELL AS PHYSICAL STATE OF I/O.

DIAGNOSTIC BAR GRAPH DISPLAYS OF CRITICAL SYSTEM VALUES, UPDATED CONTINUOUSLY. INCLUDES PEAK DETECTION AND NUMERIC DISPLAY.

Axi dyne® Axiom® DV Brushless Servo Drive

DIMENSIONS

AXIOM DV10

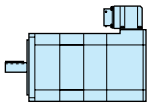
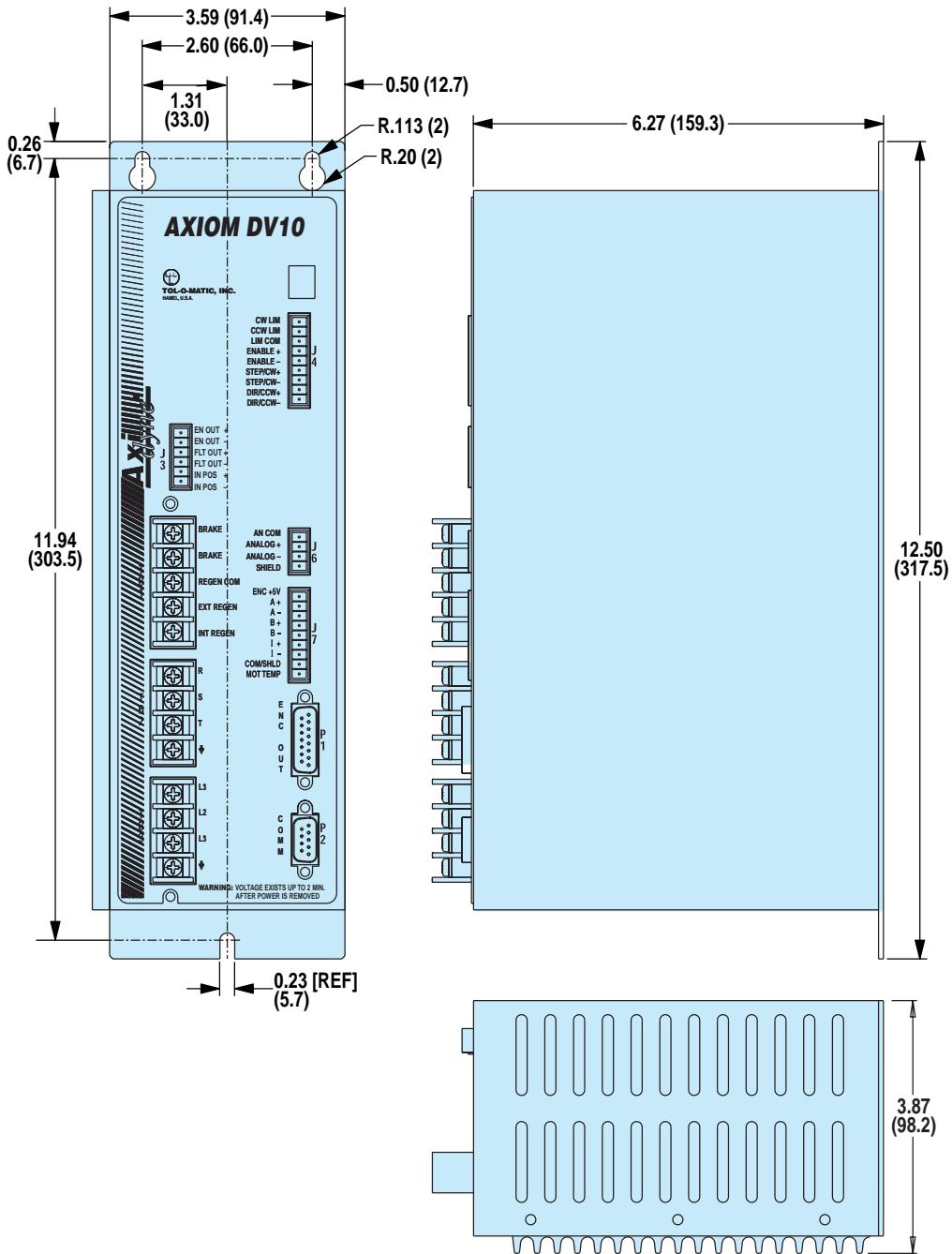

BRUSHLESS

Axiom DV Drive
• Dimensions

Unless otherwise noted, all dimensions shown are in inches (Dimensions in parenthesis are in millimeters)

Axi^{dyne}® Axiom[®] DV Brushless Servo Drive

DIMENSIONS

AXIOM DV20, DV30

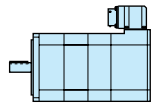
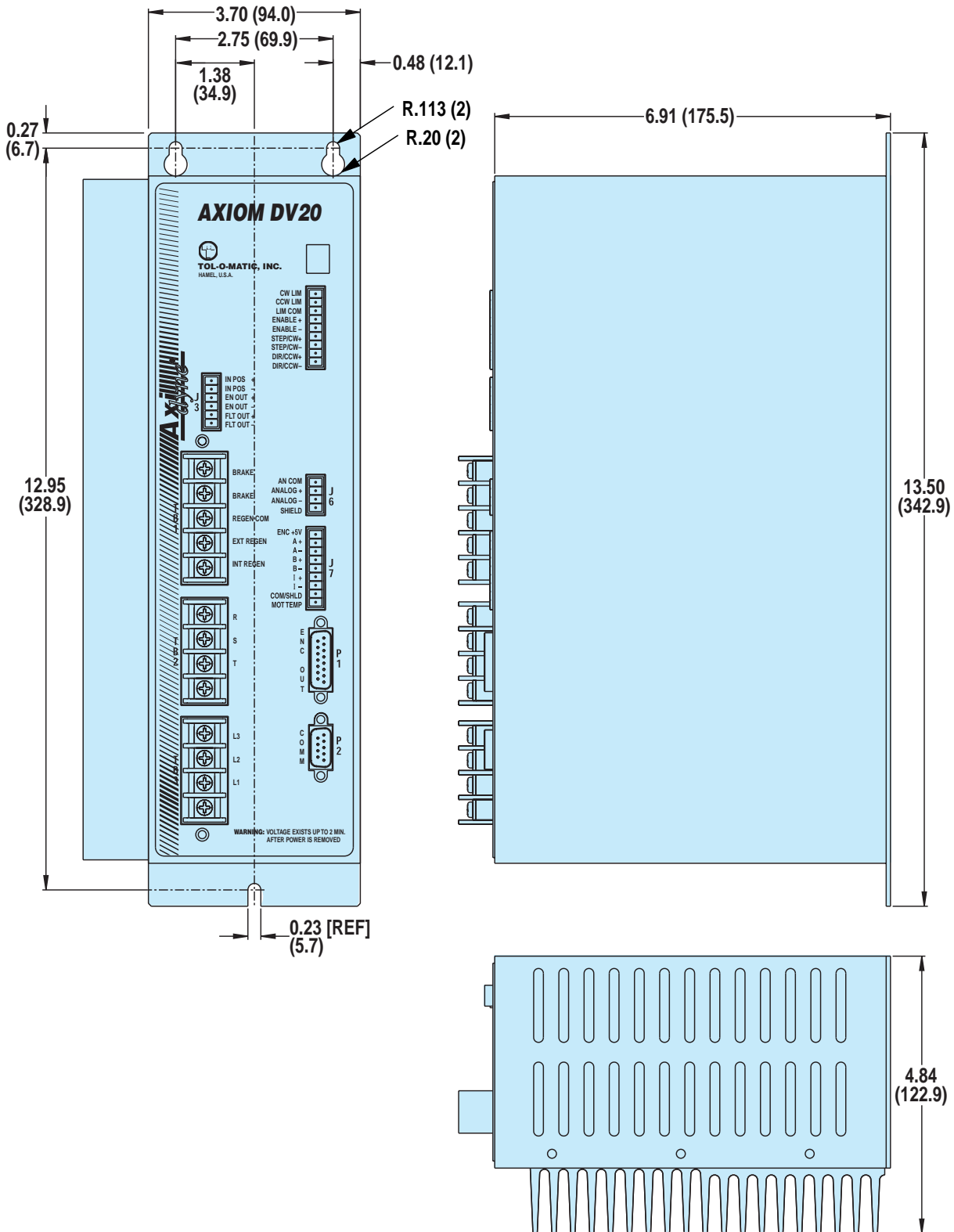

BRUSHLESS

Axiom DV Drive
• Dimensions

Axi dyne® Axiom® PV Servo Drive/Controller

FEATURES



The Axiom PV sequential motion controller offers intuitive yet sophisticated functionality. The integrated PLC performs real-time scans on a separate thread and communicates through software rather than physical wiring. Windows®-based software utilizes a point and click sequential program and PLC ladder logic editor, allowing programming without learning code. The Axiom PV incorporates the same vector drive technology used in our Axiom DV drive. It is price competitive with integrated motion controllers/drives that do not offer PLC capability.

COMPATIBILITY:
 SYSTEM: BRUSHLESS
 MOTORS: MRV
 DRIVE: AXIOM PV
 CONTROLLER: AXIOM PV
 INTERFACE: JS
 SIT

AXIOM® PV FEATURES

PLC:

- Real-time scan supervisory function continuous from power-up
- Typical scan time of 2-4 milliseconds
- Ladder logic allows 175 rungs, 4 lines deep, 5 input operations, and an output coil
- Operations include: normally-open, normally-closed, logical invert, one-shot, output coil, latch, unlatch, timers and counters
- 64 character rung descriptor downloaded and uploaded with program
- Internal bit-flags for information transfer between controller and PLC

DRIVE:

- PV series drives use space vector commutation providing better bus voltage utilization than traditional sine drives for improved speed/torque curves
- Flux vector current control provides accurate high bandwidth control of torque producing current for better efficiency and more torque over the full speed range than with traditional sine drives
- Drives MRV series brushless servo motors or can be configured for customer specified linear or rotary 3-phase brushless servo motors
- Autophasing eliminates the need for Hall sensors in motors
- Drive enable input

MOTION CONTROLLER:

- 1.5 axis (gearing to auxiliary axis)
- Commands include: absolute, incremental and velocity moves, branch to labels, subroutine calls, repeat loops, time delays, wait on conditions/inputs, output/flag control and parameter value changes including torque limit, following error, position band, follower gear ratio, and maximum velocity
- Event triggering based on intermediate positions
- Motion pause and resume
- Comment lines and labels down-loaded and uploaded with program

GENERAL:

- Modbus RTU and ASCII interface
- Pluggable screw terminal connectors eliminate the need for special connectors and secondary breakout terminal strips
- Short circuit, over current and over voltage protection prevents drive damage
- 25W or 50W internal regeneration
- External regeneration connections
- CW/CCW travel limit inputs
- Fault, enabled, and in-position outputs
- 3A brake relay
- 3 second peak ratings

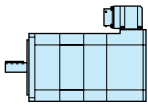

BRUSHLESS

**Axiom PV
Drive/Controller**

• Features

Axi dyne[®] Axiom[®] PV Servo Drive/Controller

SPECIFICATIONS

AXIOM[®] PV SPECIFICATIONS

SPECIFICATIONS	Axiom [®] PV Series Drives		
Power	PV10	PV20	PV30
Peak Output Current:	10 Amps	20 Amps	30 Amps
Continuous Output Current:	5 Amps	10 Amps	15 Amps
Continuous Output Power:	1.4 kW	2.8 kW	4.2 kW
Input Voltage:	95 Vac - 250 Vac 1Ø; 95 Vac - 250 Vac 3Ø (voltage range is switch selectable)		
Input Frequency:	47Hz - 63Hz		
User Programming			
Language/Programming Environment:	Tol-O-Motion™ windows-based software with point and click sequential program and PLC ladder logic editors		
Firmware Field Upgradeable:	YES		
User Program Storage Capacity:	500 lines of graphic-based, high-level sequential motion and control instructions with unlimited subroutine calls.		
PLC			
Connection/Capabilities:	Internal PLC with typical real-time scan of 2-4 msec, 10-12 msec for programs of maximum capacity; 15 inputs		
Interface			
Interfaces supported:	Modbus RTU ASCII		
Inputs/Outputs			
General-Purpose Digital Inputs:	15 optically isolated 5-25 Vdc		
Inputs/Outputs:	Sinking/sourcing selectable		
General-Purpose Digital Outputs:	8 optically isolated, 5-25 Vdc, 20 mA maximum		
Communications:	Serial: RS-232, 19,200 baud rate		
Motor Feedback			
Input Modes:	Incremental with index		
Maximum Input Frequency:	4 MHz (post-quadrature)		
Commutation Startup:	Auto-phase - no Hall sensors required		
Connectors			
Auxiliary Feedback, I/O, Analog I/O:	Wire trap screw terminals		
Motor Feedback:	Wire trap screw terminals		
Serial Port:	9-pin D-sub		
Main AC, Motor Power and DC Bus:	Screw terminal block		
Approvals: UL, CUL, CE			
Environmental			
Storage Temperature:	-40°C to 70°C (-40°F to 158°F)		
Operating Temperature:	0°C to 50°C (32°F to 126°F)		
Humidity:	5% to 95% noncondensing		
Weight	PV10	PV20	PV30
	8.5 lbs (3.85 kg)	12.5 lbs (5.66 kg)	12.5 lbs (5.66 kg)

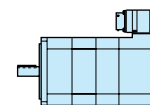

BRUSHLESS

**Axiom PV
Drive/Controller**

• Specifications

Axi dyne[®] Axiom[®] PV Servo Drive/Controller

CONNECTORS

AXIOM[®] PV CONNECTORS

TB1 - BRAKE/REGEN

1 - Brake	2 - Brake
3 - Regen Com	4 - External Regen
5 - Internal Regen	

TB2 - MOTOR

1 - Motor R	2 - Motor S
3 - Motor T	4 - Motor Ground

TB3 - AC POWER

1 - L3	2 - L2
3 - L1	4 - Ground

J1 - Outputs

1 - Output 1 +	2 - Output 1 -
3 - Output 2 +	4 - Output 2 -
5 - Output 3 +	6 - Output 3 -

J2 - OUTPUTS

1 - +24Vdc	2 - 24Vdc Return
3 - Output 4 +	4 - Output 4 -
5 - Output 5 +	6 - Output 5 -

J3 - OUTPUTS

1 - Output 6 +	2 - Output 6 -
3 - Output 7 +	4 - Output 7 -
5 - Output 8 +	6 - Output 8 -

J4 - INPUTS

1 - +24Vdc	2 - 24Vdc Return
3 - Com 1 - 6	4 - Input 1
5 - Input 2	6 - Input 3
7 - Input 4	8 - Input 5
9 - Input 6	

J5 - INPUTS

1 - +24Vdc	2 - 24Vdc Return
3 - Com 7 - 12	4 - Input 7
5 - Input 8	6 - Input 9
7 - Input 10	8 - Input 11
9 - Input 12	

J6 - INPUTS

1 - Com 13 - 15	2 - Input 13
3 - Input 14	4 - Input 15

J7 - MOTOR ENCODER

1 - Encoder +5V	2 - A +
3 - A -	4 - B +
5 - B -	6 - I +
7 - I -	8 - Com/Shld
9 - Motor Temp	

P1 - Buffered encoder out/auxiliary encoder

1 - +5V Encoder	2 - Aux Encoder A +
3 - Aux Encoder A -	4 - Aux Encoder B +
5 - Aux Encoder B -	6 - Aux Encoder I +
7 - Aux Encoder I -	8 - Encoder Common
9 - Motor Encoder Out A +	
10 - Motor Encoder Out A -	
11 - Motor Encoder Out B +	
12 - Motor Encoder Out B -	
13 - Motor Encoder Out I +	
14 - Motor Encoder Out I -	
15 - Reserved	

P2 - COMMUNICATIONS

1 - Reserved	2 - RS-232 TX
3 - RS-232 RX	4 - Reserved
5 - Common	6 - Reserved
7 - Reserved	8 - Reserved
9 - +5Vdc (30mA Max.)	

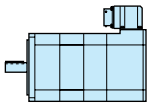

BRUSHLESS

Axiom PV
Drive/Controller

- Connectors

Axi^{dyne}® Axiom® PV Servo Drive/Controller

PLC / Sequential program editors

Axiom® PV set-up and configuration software has a similar look and feel to the Axiom DV software. A configuration option for motor selection and related parameters is included, along with a tuning and diagnostic mode. Help menus and control loop description information can be accessed from the main menu.

The Axiom PV also includes a point and click sequential program and PLC ladder logic editor. Instructions include incremental and absolute motion commands, branching (conditional and unconditional), subroutine calls, repeat loops, I/O control, time delays, etc. Use the PLC editor to enter and edit PLC programs, which run using an independent scan. The PLC program accesses all 15 inputs and 8 outputs of the Axiom PV, including general purpose and dedicated internal flags.

Both of these editors utilize easy icon/text driven selections, making the creation of motion profiles a snap (no code memorization required).

AXIOM® PV PLC EDITOR

The PLC Editor main menu allows user access to all editing functions along with a 175 rung ladder display. Rungs can be inserted at any point in the program and are easily edited by simply double-clicking with the mouse and selecting the desired functions from subsequent menus. The PLC program's real-time scan is continuous upon power-up and ranges from 2-4 milliseconds for a typical application, with 10-12 milliseconds for a maximum-length program.

ALL USER COMMENTS ARE STORED WITH THE PLC PROGRAM WHEN DOWNLOADED TO THE AXIOM PV.

COMPLETE LADDER LISTING ALONG WITH I/O FLAGS CAN BE PRINTED OUT FOR REFERENCE.

REAL-TIME SCAN FUNCTION CONNECTS TO AXIOM PV AND MONITORS LOGICAL STATE OF ALL I/O AND FLAGS IN PLC PROGRAM.

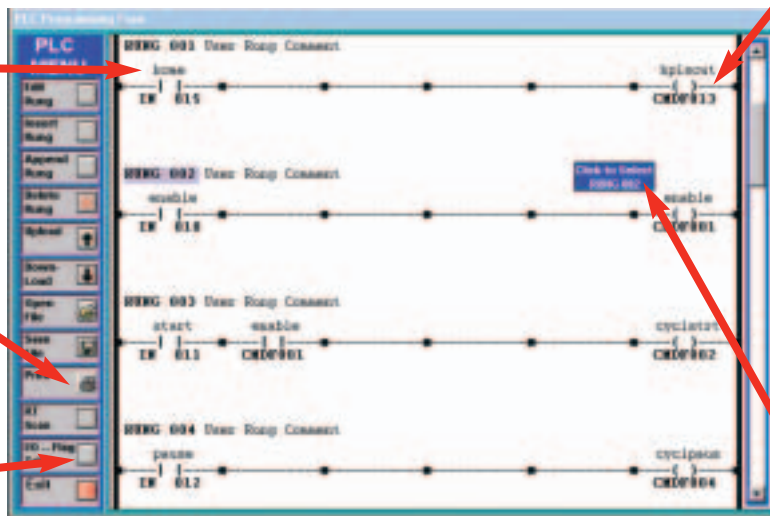

UP TO 500 LINES OF GRAPHIC-BASED, HIGH-LEVEL SEQUENTIAL MOTION AND CONTROL INSTRUCTIONS, WITH UNLIMITED SUBROUTINE CALLS. EACH RUNG CAN BE 4 LINES DEEP AND 5 INPUT OPERATIONS IN WIDTH, PLUS THE OUTPUT COIL.

UP TO 64 CHARACTERS DESCRIPTION FOR EACH RUNG FUNCTION AND 8 CHARACTERS FOR OPERAND COMMENTS.

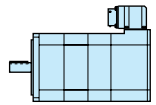

BRUSHLESS

Axiom PV Drive/Controller
 • PLC / sequential program editors

OPERANDS ARE EASILY SELECTED WITH USER COMMENTS AND "IN-USE" DESIGNATION DISPLAYS.

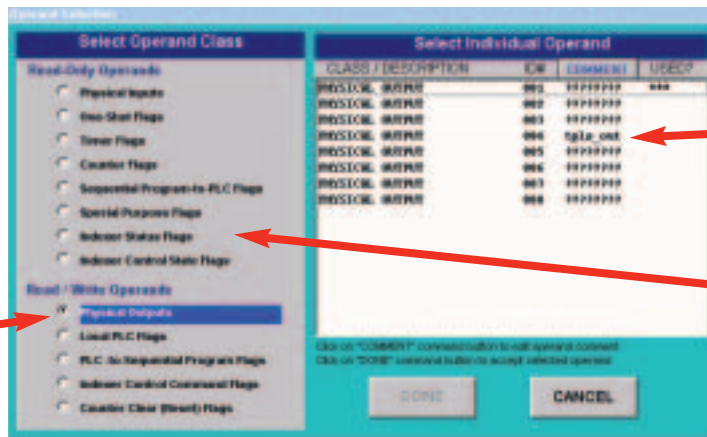

OPERANDS ARE EASILY SELECTED WITH USER COMMENTS AND "IN-USE" DESIGNATION DISPLAYS.

OPERATIONS SUPPORTED INCLUDE: NORMALLY-OPEN, NORMALLY-CLOSED, LOGICAL INVERT, ONE-SHOT, OUTPUT COIL, LATCH, UNLATCH, TIMERS, AND COUNTERS.

Axi-dyne® Axiom® PV Servo Drive/Controller

PLC / Sequential program editors

AXIOM® PV SEQUENTIAL PROGRAM EDITOR

The Sequential Editor main menu provides easy access to all essential program and display functions. Using a series of menus, the program guides the user through instruction selection. The Incremental Position Move window allows two separate trigger moves to be defined based on incremental position reached, physical input transition or flag from the PLC. Two actions can be commanded for each trigger event including torque limit or velocity change, output control or flag passing to PLC. This functionality allows an almost limitless combination of functions associated with a single move, while the PLC facilitates real-time control.

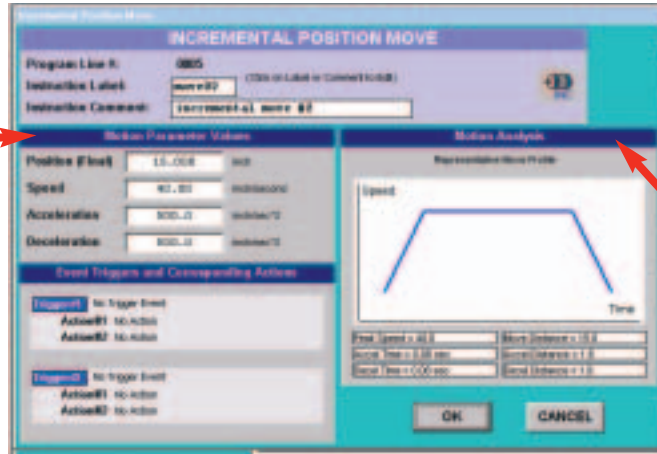

ENTERED MOTION PARAMETERS INSTANTLY UPDATE MOTION PROFILE TO SHOW MOVE TRAJECTORY

ENTERED MOTION PARAMETERS INSTANTLY UPDATE MOTION PROFILE TO SHOW MOVE TRAJECTORY

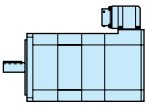

BRUSHLESS

Axiom PV Drive/Controller
 • PLC / sequential program editors

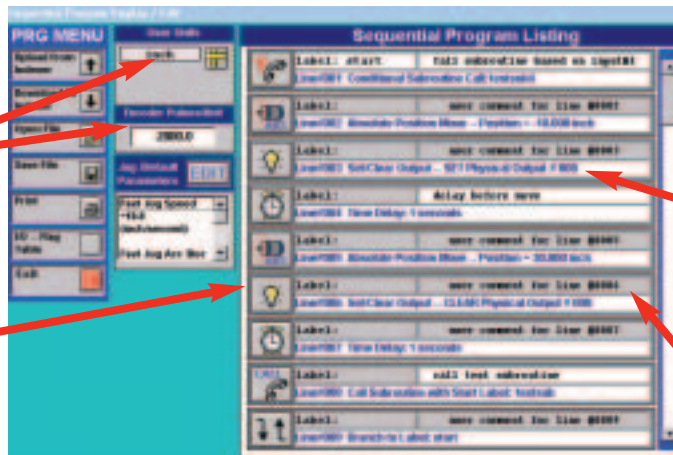

DECIMAL PRECISION USER UNITS AND TWO JOG SPEEDS.

CLICK DESIRED AREA OF DISPLAY TO EDIT

ALL USER COMMENTS AND LABELS ARE STORED WITH THE PROGRAM WHEN DOWNLOADED TO THE AXIOM PV.

EACH INSTRUCTION INCLUDES AN 8 CHARACTER LABEL USED FOR BRANCHING, SUBROUTINE CALL DESTINATIONS AND A 32 CHARACTER USER COMMENT.

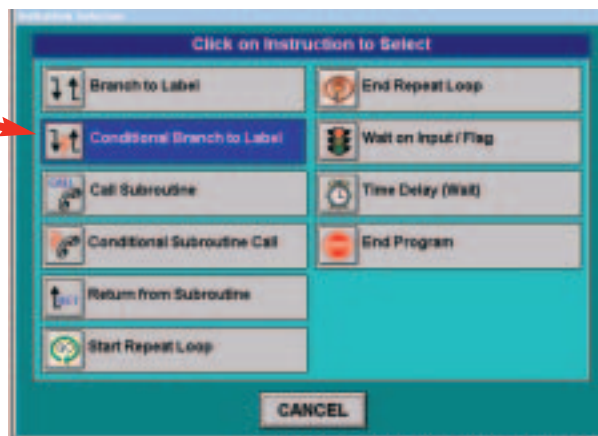

SERIES OF INSTRUCTION MENUS MAKE EASY SELECTION OF PROGRAM CONTROL, MOTION COMMANDS, ETC.

Axi dyne® Axiom® PV Servo Drive/Controller

DIMENSIONS

AXIOM PV10

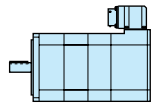
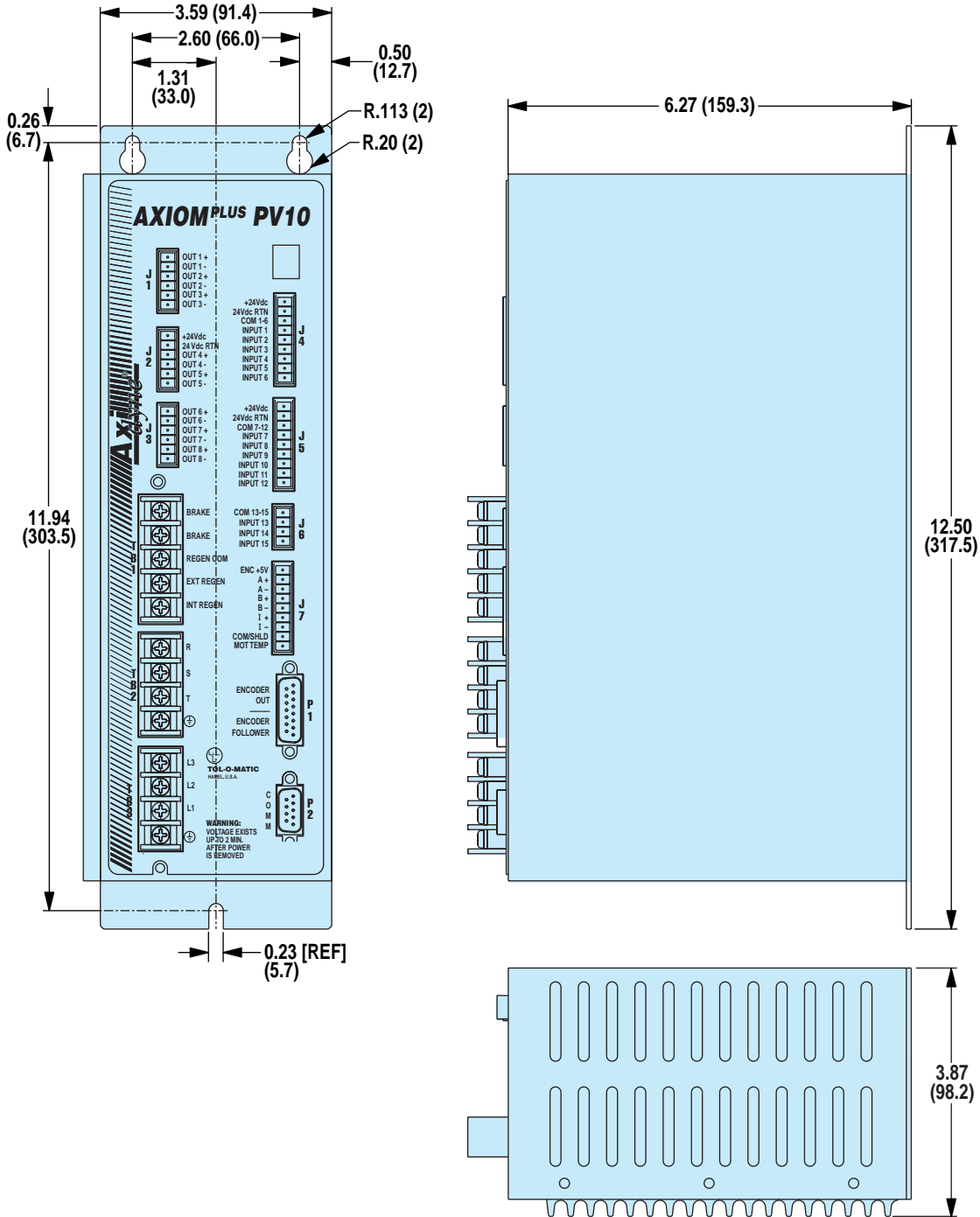

BRUSHLESS

Axiom PV Drive/Controller

- Dimensions

Unless otherwise noted, all dimensions shown are in inches (Dimensions in parenthesis are in millimeters)

Axi dyne® Axiom® PV Servo Drive/Controller

DIMENSIONS

AXIOM PV20, PV30

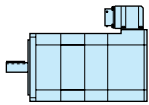
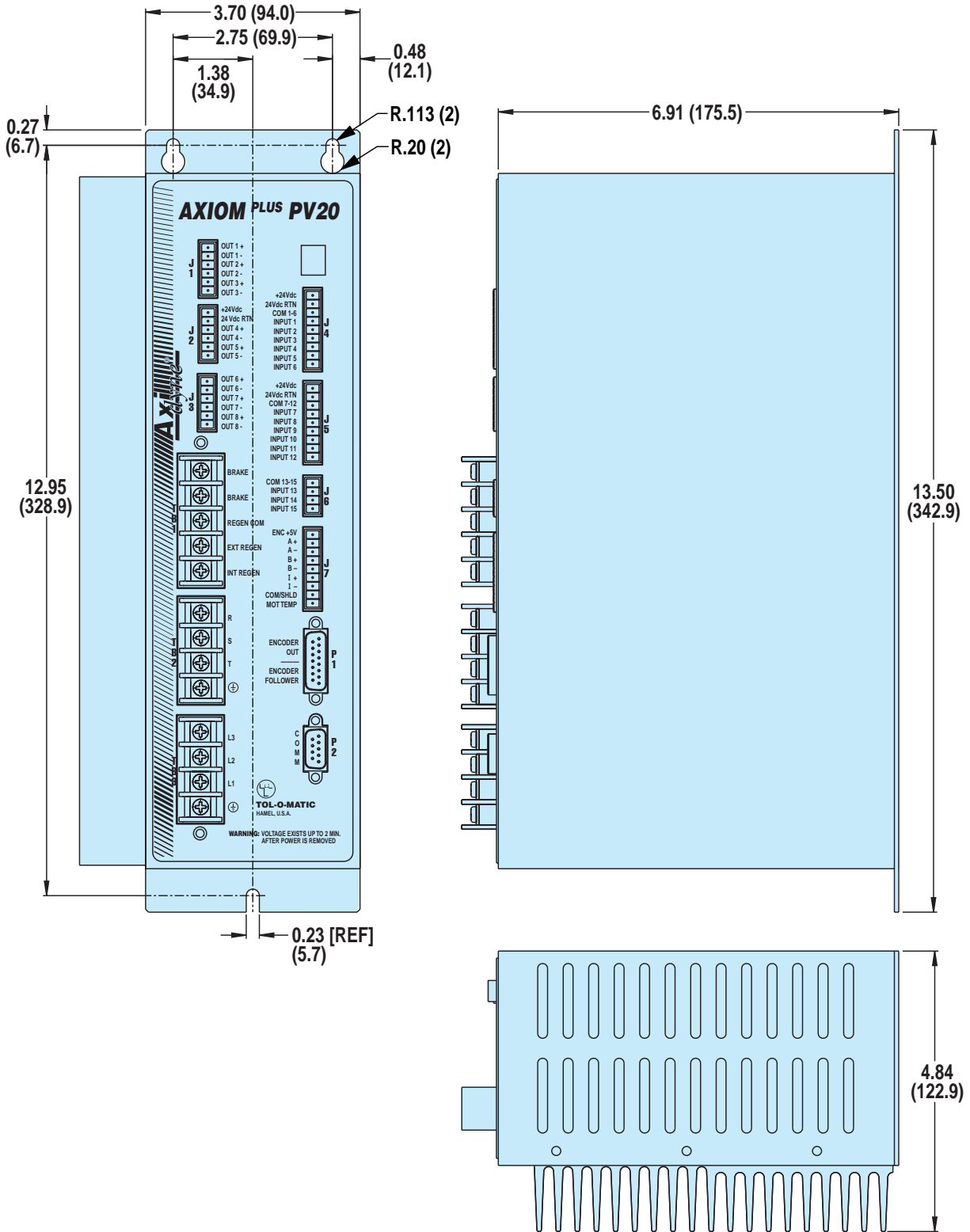

BRUSHLESS

Axiom PV
Drive/Controller
• Dimensions

Axi-dyne[®] SSC Multi-axis Servo/Stepper Controller

FEATURES

COMPATIBILITY:

SYSTEM: BRUSHLESS

MOTORS: MRV

DRIVE: AXIOM DV

CONTROLLER: SSC

INTERFACE: JS
SIT

COMPATIBILITY:

SYSTEM: STEPPER

MOTORS: MRS

DRIVE: MSD

CONTROLLER: SSC

INTERFACE: JS
SIT

COMPATIBILITY:

SYSTEM: BRUSHED DC

MOTORS: MRB

DRIVE: AXIOM DB

CONTROLLER: SSC

INTERFACE: JS
SIT



The SSC is a high-performance, state-of-the-art motion controller designed for stand-alone operation. This cost effective controller uses a 32-bit microprocessor, a sub-micron gate array, and Tol-O-Motion SSC software, to provide DSP performance without sacrificing ease of use.

Available with up to 4 axes per unit, purchase only the number of axes required. It can simultaneously control stepper and /or servo systems.

Designed to solve complex motion problems with superior precision, the SSC can be used for applications requiring jogging, vector positioning of multi-axis, 2-dimensional linear or circular interpolation, contouring and electronic gearing.

With the Tol-O-Motion SSC software there is no need to learn programming language. Complex motion control is made easy with an interface that streamlines the entire programming process from setup to execution.

SSC FEATURES

- High performance motion control packaged in an industrial enclosure
- Uses a 32-bit specialized microcomputer and custom, submicron gate array for highest performance and speed
- Up to 4 axes per unit — up to 8 units can be daisy-chained
- 125 μ sec per axis servo update rate for high bandwidth
- Controls servo motors and/or step motors
- Sophisticated PID filter with velocity and acceleration feed forward for optimum precision
- 16 bit DAC for fine resolution control
- 256K RAM memory for holding and running active program up to 1000 lines x 80 characters
- 4M EEPROM memory for non volatile storage of custom application programs, parameters and arrays (8000 array elements x 30 arrays) — permits stand-alone operation
- Multitasking feature permits simultaneous execution of four independent applications programs
- Programmable acceleration and deceleration with profile smoothing to eliminate jerk
- Continuous vector feed of infinite number of linear and arc segments for smooth motion
- Selectable linear scale simplifies linear motion programming
- Contour mode for profiling along computer generated paths such as parabolic or spherical profiles
- Performs any motion task including jogging, point-to-point positioning, linear and circular interpolation, electronic gearing, cam and contouring
- Dedicated opto-isolated inputs for home, abort, forward and reverse limits — noise immune
- Position feedback for each axis can be from analog signal or encoder
- Auxiliary encoder inputs and dual-loop damping — ideal for backlash compensation
- Programmable event triggers for monitoring elapsed time, position, speed, and motion complete
- I/O functions, timers, and logic functions for executing PLC tasks
- 254 symbolic variables and 8000 element array space for data storage
- Internal, universal switching power supply for direct connection to AC outlet (115V or 230V)
- IDC connectors on front panel connect to DIN rail mounted screw terminal breakouts included
- Additional I/O available on request

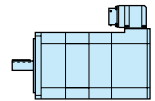

BRUSHLESS

SSC Servo/Stepper Controller

- Features

Axi dyne[®] SSC Multi-axis Servo/Stepper Controller

SPECIFICATIONS

SSC SPECIFICATIONS

Performance

Servo Loop Cycle Time:	SSC 1: 250 μ sec; SSC 2: 375 μ sec SSC 3: 500 μ sec; SSC 4: 500 μ sec
Block Execution Time:	In contour mode, up to 1000 blocks (moves)/sec with full trajectory calculation
Position Accuracy:	± 1 quadrature count
Velocity Accuracy:	Long-term: phase-locked, better than 0.003% Short-term: system dependent
Synchronization:	All axes in the same unit are perfectly synchronized and share the same servo cycle.
Position Capture Accuracy:	25 μ sec with opto-isolation; 1 μ sec if by-pass opto-isolation.

Parameter Ranges

Position Range:	$\pm 2,147,483,647$ counts/move; automatic rollover; no limit in jog or vector modes.
Velocity Range:	Up to 8,000,000 counts/sec
Acceleration/deceleration:	1,024 to 67,107,840 c/sec ²
Error Limit:	$\pm 32,767$ counts
Gear Ratio:	± 127.9999
Filter Constants:	Kp: 0 to 1023.875 Kd: 0 to 4095.875 Ki: 0 to 2047.875
Motor Command Resolution:	16-bits or .0003 V
Step Motor Control Mode:	Full, half or microstep
Step Pulse Frequency:	2,000,000 pulse/sec
Number of Variables:	254
Array Memory Size:	8000 elements in up to 30 arrays
Program Memory Size:	1000 lines x 80 characters

Mechanical

Dimensions:	13" high x 2.5" wide x 6.6" deep
Weight:	6 lbs.

Inputs/Outputs

Feedback:	Two channels of A/B quadrature per axis with third channel for index. In servo mode, includes auxiliary encoder inputs for each axis. Single ended or differential. Can be configured for quadrature, pulse and direction, or from analog inputs.
General Purpose Inputs:	8 opto-isolated inputs
General Purpose Outputs:	8 TTL outputs
General Purpose Analog Inputs:	7, ± 10 V; 12-bit resolution (16-bit optional)
Dedicated Inputs per Axis:	Forward and reverse limits, home.
Dedicated Outputs per Axis:	Analog motor command, pulse and direction, amplifier enable

Available Power to Drive External Devices

+5 V	1.5 Amp	+12 V	750 mA	-12 V	200 mA
------	---------	-------	--------	-------	--------

Environment

Operating Temperature:	32° to 158° F (0° to 70° C)
------------------------	-----------------------------

Communication Interface

Selectable Baud Rate:	300, 1200, 4800, 9600, 19200, 38400. Handshake mode available.
-----------------------	---

I/O Description (Inputs)

Encoder, A+, B+:	Position feedback from incremental encoder with two channels in quadrature. The encoder can be (± 12 V) or TTL. Note: Encoders that produce output in a pulse and direction format can also be used.
Encoder Index I+:	Once-per-revolution encoder pulse; used in Homing sequence or Find Index command. Minimum index pulse width is 120 nsec.
Encoder, A-, B-, I-:	Optional differential inputs from encoder; used for enhanced noise immunity.
Auxiliary Encoder:	Inputs for additional encoder; used when encoders on both the motor and the load are required.
Abort #:	Stops commanded motion instantly and also aborts application program.
Reset #:	System reset.
Forward and Reverse Limit Switch #:	When active, inhibits motion in forward or reverse direction and also causes the limit switch subroutine #LIMSWI to execute.
Home Switch #:	Input for Homing (HM) and Find Edge (FE) instructions.
Input 1 - Input 8#:	Uncommitted inputs; can be defined by the user to trigger events or interrupt program.
Latch#:	High-speed position latch to capture axis position within 25 μ sec (bypass opto-isolation for .1 μ sec capture). AL command arms latch. Input 1, 2, 3, 4 latches X, Y, Z, W respectively.
Analog 1 - Analog 7:	Analog inputs that can be connected to external analog signals such as force or pressure transducers. Can also be used for position feedback. 12-bit resolution ADC for ± 10 V input.

I/O Description (Outputs)

Analog Motor Command:	± 10 V range signal for driving servo amplifiers; 16-bit resolution or .0003 V, 3 mA.
Amp enable:	Signal to disable and enable an amplifier. Amp enable goes low when a motor-off condition occurs. For step motors, this pin provides for reduced current when low.
Step Out:	Pulses for input to a step motor driver. The pulses can be either active low or high. Upon Reset, the output will be low if the SM jumper is on, Tristate if off. The STEP OUT pin also provides the PWM signal for servo motors.
Direction:	Used with the STEP OUT signal to give direction to step motors or servo motors in the sign magnitude mode.
Error:	The signal goes low when the position error on any axis exceeds the limit specified by the error command, ER.
Output 1 - Output 8:	These 8 TTL outputs are uncommitted and can be designated by the user to toggle relays and trigger external events. The output lines are toggled by Set Bit (SB), Clear Bit (CB), Define Bit (OB), and OP instructions. Upon reset these signals will be low.

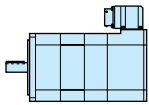

BRUSHLESS

SSC Servo/Stepper Controller

• Specifications

SSC CONNECTORS

SSC J2 Main; 60-Pin IDC;

1 Ground	2 5V		
3 Error	4 Reset		
5 Switch Common	6 Forward Limit - X		
7 Reverse Limit - X	8 Home - X		
9 Forward Limit - Y	10 Reverse Limit - Y		
11 Home - Y	12 Forward Limit - Z		
13 Reverse Limit - Z	14 Home - Z		
15 Forward Limit - W	16 Reverse Limit - W		
17 Home - W	18 Output 1		
19 Input Common	20 Latch X or Input 1		
21 Latch Y or Input 2	22 Latch Z or Input 3		
23 Latch W or Input 4	24 Abort Input		
25 Motor Command X	26 Amp Enable X		
27 Motor Command Y	28 Amp Enable Y		
29 Motor Command Z	30 Amp Enable Z		
31 Motor Command W	32 Amp Enable W		
33 A+ X	34 A- X	35 B+ X	36 B- X
37 I+ X	38 I- X	39 A+ Y	40 A- Y
41 B+ Y	42 B- Y	43 I+ Y	44 I- Y
45 A+ Z	46 A- Z	47 B+ Z	48 B- Z
49 I+ Z	50 I- Z	51 A+ W	52 A- W
53 B+ W	54 B- W	55 I+ W	56 I- W
57 +12V	58 -12V	59 5V	60 Ground

SSC J5 General I/O; 26-Pin IDC;

1 Analog 1	2 Analog 2
3 Analog 3	4 Analog 4
5 Analog 5	6 Analog 6
7 Analog 7	8 Ground
9 5V	10 Output 1
11 Output 2	12 Output 3
13 Output 4	14 Output 5
15 Output 6	16 Output 7
17 Output 8	18 Input 8
19 Input 7	20 Input 6
21 Input 5	22 Input 4 (Latch W)
23 Input 3 (Latch W)	24 Input 2 (Latch W)
25 Input 1 (Latch W)	26 Input Common (Isolated 5V)

SSC J3 Auxiliary Encoder; 20-Pin IDC;

1 Sample Clock	2 Reserved
3 B- Aux W	4 B+ Aux W
5 A- Aux W	6 A+ Aux W
7 B- Aux Z	8 B+ Aux Z
9 A- Aux Z	10 A+ Aux Z
11 B- Aux Y	12 B+ Aux Y
13 A- Aux Y	14 A+ Aux Y
15 B- Aux X	16 B+ Aux X
17 A- Aux X	18 A+ Aux X
19 5V	20 Ground

SSC J4 Driver; 20-Pin IDC;

1 Motor Command X	2 Amp Enable X
3 PWM X/Step X	4 Sign X/Dir X
5	6 Motor Command Y
7 Amp Enable Y	8 PWM Y/Step Y
9 Sign Y/Dir Y	10
11 Motor Command Z	12 Amp Enable Z
13 PWM Z/Step Z	14 Sign Z/Dir Z
15 5V	16 Motor Command W
17 Amp Enable W	18 PWM W/Step W
19 Sign W/Dir W	20 Ground

AC Power INputs; 4-PIN Detachable Screw Type:

Hot Connects to 110 or 220 AC	
NC	No Connect
Neutral	Return for AC
Earth	Chassis input

RS232 - Main Port; 9-PIN:

1 CTS - output	2 Transmit data
3 Receive data	4 RTS - input
5 Ground	6 CTS - output
7 RTS - input	8 CTS - output
9 5V	

RS232 - Auxiliary Port; 9-PIN:

1 CTS - input	2 Receive data -
3 Transmit data	4 RTS - output
5 Ground	6 CTS - input
7 RTS - output	8 CTS - input
9 5V	

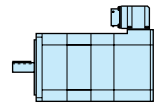

BRUSHLESS

SSC Servo/Stepper Controller
• Connectors

Axi-dyne[®] SSC Multi-axis Servo/Stepper Controller

PROGRAMMING SOFTWARE

SSC PROGRAMMING SOFTWARE

Programming is accomplished through RS232 connection to a PC running Windows 95, 98, NT, 2000 or XP. Visual Basic panels guide the user through the complete setup process including communications and axis configuration. The user can then use other program options including Display, Jog, Teach, Programmer, Tune and Data Acquisition.

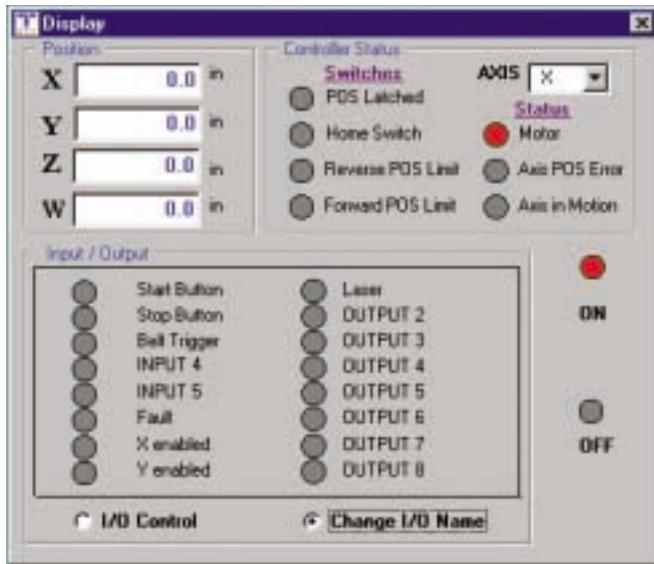

Jog

The Jog panels allow the user to easily setup independent motion or coordinated motion.

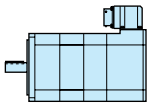

BRUSHLESS

SSC
Servo/Stepper
Controller
• Programming

Display

The Display panel (shown above) allows the user to identify axis locations and status faults, limits, and I/O.



CIRCULAR MOTION

The added feature of 2-dimensional circular programming, assists you in selecting start and sweep angles.

Axi-dyne[®] SSC Multi-axis Servo/Stepper Controller

DIMENSIONS

SSC (MULTI-AXIS SERVO/STEPPER CONTROLLER)

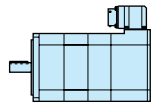
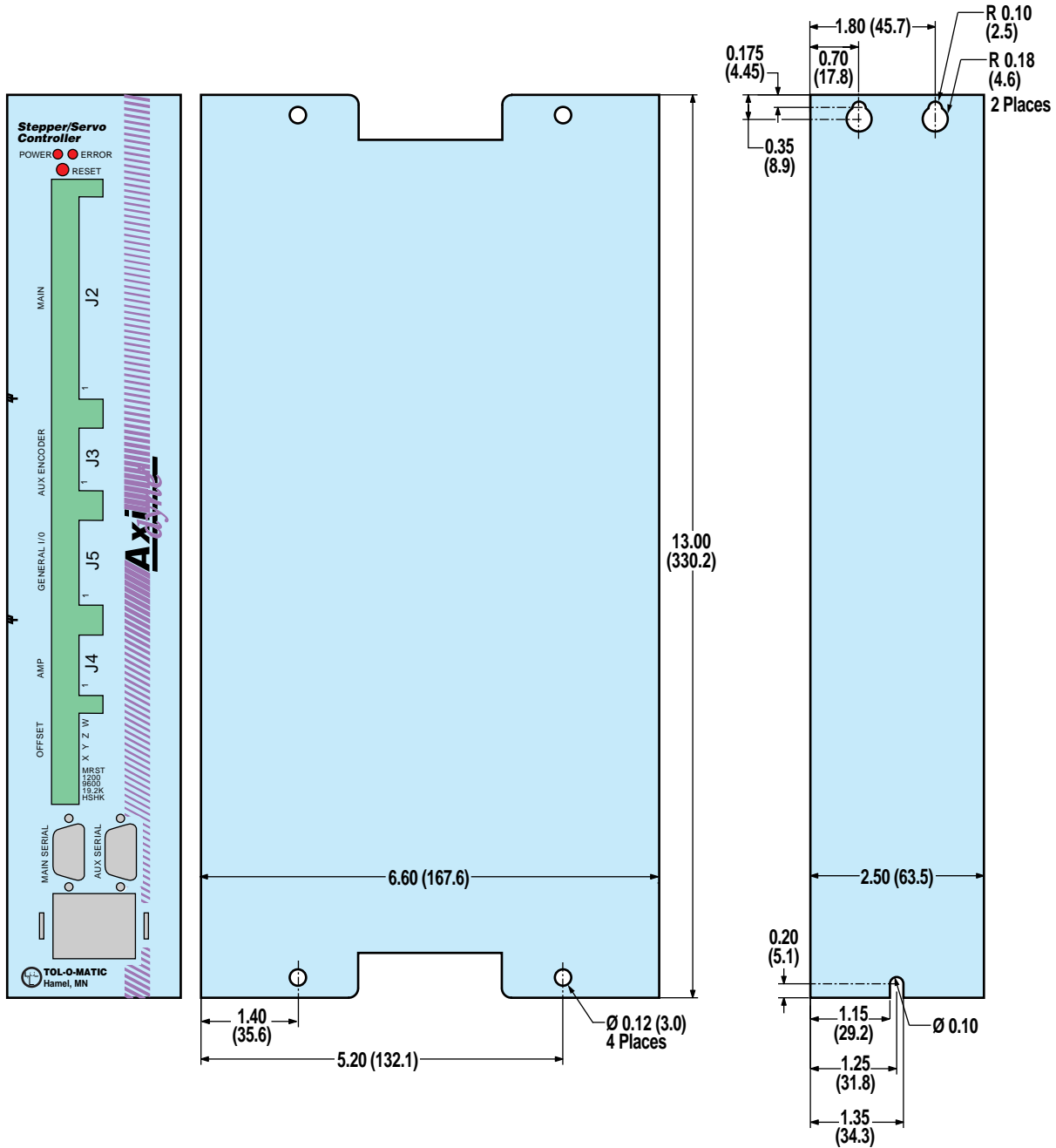

BRUSHLESS

SSC Servo/Stepper Controller
 • Dimensions

Unless otherwise noted, all dimensions shown are in inches (Dimensions in parenthesis are in millimeters)

Axi-dyne[®] JS – Joystick User Interface

SPECIFICATIONS AND DIMENSIONS

COMPATIBILITY:
 SYSTEM: BRUSHLESS
 MOTORS: MRV
 DRIVE: AXIOM DV
 CONTROLLER: SSC

INTERFACE: JS
 SIT

COMPATIBILITY:
 SYSTEM: STEPPER
 MOTORS: MRS
 DRIVE: MSD
 CONTROLLER: SSC

INTERFACE: JS
 SIT

COMPATIBILITY:
 SYSTEM: BRUSHED DC
 MOTORS: MRB
 DRIVE: AXIOM DB
 CONTROLLER: SSC

INTERFACE: JS
 SIT



For simple setup of the SSC controller the JS joystick provides 2-axis manipulation. Used with the Joystick Teach mode of the Tol-O-Motion SSC software, moves can be made with velocity control, and then stored using a separate button integrated into the joystick housing.

SPECIFICATIONS	JS Joystick
Joystick Travel	27° from design center in all directions
Mechanical Life Cycle	5 million (minimum)
Trim Movement (Optional)	±7° (total trim 14°) for each axis
Main Ball Pivot	Precision ground stainless steel
Stick Shaft	3/16" brass plated
Potentiometers	Set at center of resistance
Potentiometer Calibration	Thumb tab provides up to 114° of potentiometer calibration
Return to Center Repeatability	±1%
Deflection Force	0.14 lbs. at 27° at 2-7/8" from pivot point
Switches	2 elongated push-button switches
Cable	Integrated 7' (2.1m) cable with strain relief

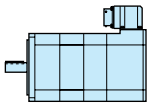

BRUSHLESS

JS Joystick User Interface

- Specifications
- Dimensions

JS (JOYSTICK) DIMENSIONS

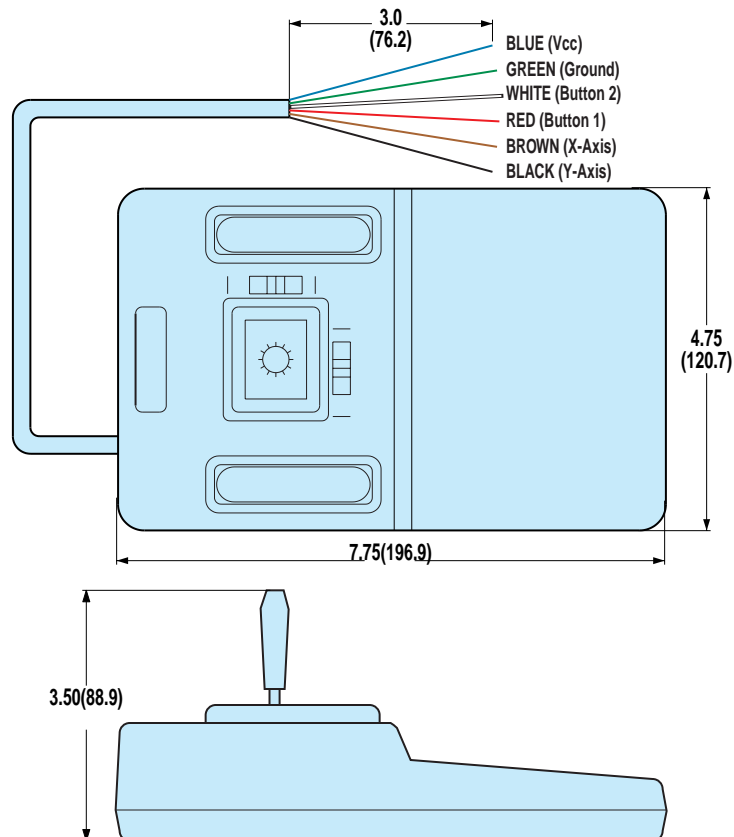

Unless otherwise noted, all dimensions shown are in inches (Dimensions in parenthesis are in millimeters)

Axi-dyne® SIT – Hand-held, user interface

FEATURES AND DIMENSIONS

COMPATIBILITY:
 SYSTEM: BRUSHLESS
 MOTORS: MRV
 DRIVE: AXIOM DV
 CONTROLLER: SSC
 INTERFACE: JS
 SIT

COMPATIBILITY:
 SYSTEM: STEPPER
 MOTORS: MRS
 DRIVE: MSD
 CONTROLLER: SSC
 INTERFACE: JS
 SIT

COMPATIBILITY:
 SYSTEM: BRUSHED DC
 MOTORS: MRB
 DRIVE: AXIOM DB
 CONTROLLER: SSC
 INTERFACE: JS
 SIT



For user interaction with the SSC 1-4 axis multi-function controllers the SIT hand held user interface provides flexibility and setup simplicity. The Tol-O-Motion SS software (included with the SSC 1-4 controllers) has a setup page for use with the SIT to allow the controller to status the user, or to prompt the user for information, eliminating the need for a PC following setup.

FEATURES:

- 45 key, alpha-numeric tactile keypad
- 4 row by 20 character LCD display
- Rugged, high impact ABS housing
- 7 foot (2.1m) RS232 cable with 9-pin “D” connector for connection to the SSC 1-4
- 5 Vdc power supplied from SSC 1-4 controller over RS232

SPECIFICATIONS	JS Joystick
Weight	8.0 oz. (.23 Kg.)
Character Set	ASCII with upper case transmit, upper and lower case receive
Case	Molded, high impact ABS with retractable hanger
Keypad	15 user-programmable function keys
Display	Transreflective LCD with 5 by 7 character font
Power Requirements	30 mA maximum, regulated, 5 Vdc \pm 5% (Received through RS 232 cable)
Speaker	Audible key click, bell and alert
Storage Temperature	-4° F (-20° C) to 158° F (+70° C)
Operating Temperature	32°F (0° C) to 122° F (+50° C)
Relative Humidity	10% to 90% non-condensing

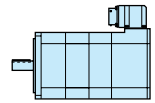

BRUSHLESS

SIT Hand-held User Interface

- Features
- Specifications
- Dimensions

SIT (HAND-HELD INTERFACE)

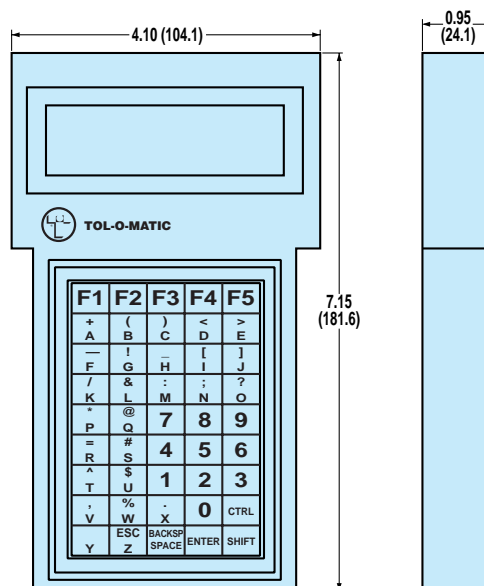

Axi-dyne® Brushless Servo System

CABLES

MRV MOTORS TO AXIOM DV DRIVE & AXIOM PV DRIVE/CONTROLLER



Config Code	Replacement Part Number	Included with Drive	Type	Description	Cable Length	Motor Size	CONNECTORS AT		Axiom DV/PV Size
							Motor	Axiom DV/PV 10	
-	-	YES	Power		18 in	All	Flying leads	Screw terminal	10
-	-	YES	Encoder		18 in	All	Flying leads	Screw terminal	10



Config Code	Replacement Part Number	Included with Drive	Type	Description	Cable Length	Motor Size	CONNECTORS AT		Axiom DV/PV Size
							Motor	Axiom DV/PV 10	
CR6	3604-1190	Optional	Power		6m	21 to 24	MS	Screw terminal	10
CR15	3604-1191	Optional	Power		15m	21 to 24	MS	Screw terminal	10
CR6	3604-1192	Optional	Power		6m	31 to 33	MS	Screw terminal	20
CR15	3604-1193	Optional	Power		15m	31 to 33	MS	Screw terminal	20
CR6	3604-1194	Optional	Power		6m	51	MS	Screw terminal	30
CR15	3604-1195	Optional	Power		15m	51	MS	Screw terminal	30
CR6	3604-1196	Optional	Encoder		6m	All	MS	Screw terminal	All
CR15	3604-1197	Optional	Encoder		15m	All	MS	Screw terminal	All

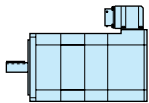

BRUSHLESS

AXIOM DV DRIVE TO SSC CONTROLLER



Config Code	Replacement Part Number	Included with SSC	Type	Description	Cable Length	Drive Sizes	CONNECTORS AT		SSC Size
							Drive	SSC	
-	3600-1347	YES	Main/Driver Signals	Ribbon Breakout	1m	All	Screw terminals ¹	IDC	All
-	3600-1342	YES							
-	3600-1346	YES	I/O	Ribbon Breakout	1m	All	Screw terminals ¹	IDC	All
-	3600-1341	YES							
-	3604-1213	YES	Controller Encoder	Encoder Feedback	3m	All	DB15 ²	Screw terminals at breakout box	All

CONTROLLER TO IBM COMPATIBLE PC



Config Code	Replacement Part Number	Included with SSC	Type	Description	Cable Length	Drive	CONNECTORS AT		PC Size
							SSC	PC	
CRZ	3600-1172	Optional	Comm		2m	AxiomPV	DB9	DB9	All
CRZ	3600-1172	Optional	Comm		2m	SSC	DB9	DB9	All

Axi-dyne® Brushless Servo System

ORDERING

MOTOR STYLE, SIZE AND GEARHEAD REDUCTION

MRV 31Y GHJ30

MOTOR TYPE

MRV Brushless Servo Motor

MOTOR SIZE / DRIVE SIZE

MODEL	FRAME SIZE	STACK SIZE	DRIVE SIZE
11Y	17	1	Axiom DV10
21Y	23	1	Axiom DV10
22Y	23	2	Axiom DV10
23Y	23	3	Axiom DV10
24Y	23	4	Axiom DV10
31Y	34	1	Axiom DV10
31Z	34	1	Axiom DV20
32Y	34	2	Axiom DV20
32Z	34	2	Axiom DV30
33Y	34	3	Axiom DV20
33Z	34	3	Axiom DV30
51Y	56	1	Axiom DV30

Once motor type and frame size is selected, the appropriate adapter and couplers required are automatically chosen.

NO DRIVE OPTION

X Replace Y or Z with X if motor drive is NOT required (do not put 'Y' or 'Z' in string)

NO MOTOR OPTION

XY* Motor(s) supplied by customer, Tol-O-Matic to mount using standard hardware and couplers

XJ* Motor(s) supplied and mounted by customer, Tol-O-Matic to furnish standard hardware and couplers

* NOTE: For XY and XJ options, a full end-face and shaft dimensional drawing must accompany the order for the actuator. Customer motors must be directly interchangeable with Tol-O-Matic motors.

GEARHEAD REDUCTIONS

(For In-line or Direct-Drive mounting configurations only)

MODEL	INPUT DIA.	MOTOR SIZE	REDUCTION RATIO
GHJ20	1/2-inch	23	5.5
GHJ21	1/2-inch	23	10
GHJ30	1/2-inch	34	5.5
GHJ31	1/2-inch	34	10

CONTROLLER CABLES, CONNECTIONS & INTERFACE

PV CR15 CRZ

CONTROLLER OR DRIVE COMBINATION

SINGLE AXIS APPLICATIONS

PV Axiom®Plus Controller/Drive (Drive size is determined by "Y" or "Z" in motor code)

SSC10 **Stepper/Servo Controller, 1 axis application
** A 15 pin D-sub 36" connector cable for each servo axis will be included with the SSC controller when ordered with Axiom drive

MULTI AXIS APPLICATIONS

2 Axis Application

	1st Axis	2nd Axis
SSC21	Servo	Stepper
SSC22	Servo	Servo

3 Axis Application

	1st Axis	2nd Axis	3rd Axis
SSC31	Servo	Stepper	Stepper
SSC32	Servo	Stepper	Servo
SSC33	Servo	Servo	Stepper
SSC34	Servo	Servo	Servo

4 Axis Application

	1st Axis	2nd Axis	3rd Axis	4th Axis
SSC41	Servo	Stepper	Stepper	Stepper
SSC42	Servo	Stepper	Stepper	Servo
SSC43	Servo	Stepper	Servo	Stepper
SSC44	Servo	Stepper	Servo	Servo
SSC45	Servo	Servo	Stepper	Stepper
SSC46	Servo	Servo	Stepper	Servo
SSC47	Servo	Servo	Servo	Stepper
SSC48	Servo	Servo	Servo	Servo

CABLES

FOR AXIOM DV OR AXIOM PV MUST SPECIFY ENCODER, POWER CABLE LENGTH

CR6 6-meter encoder cable, power cable
CR15 15-meter encoder cable, power cable

▲ MRV11 motor has flying leads, special cables are not required.

FOR SSC CONTROLLERS

CRZ If a 2-meter 9-pin RS232 cable is desired

▲ If ordering with AXIOM drive, controller encoder cables are included for each axis.

Indicate if breakout terminal and ribbon cables are needed.

BON No breakout terminals
BOY*** With breakout terminals

***BOY option includes:

- 60 pin/18" (457mm) ribbon cable & 60 pin breakout
- 26 pin/18" (457mm) ribbon cable & 26 pin breakout
- If any axis configured w/ step & direction output — 20 pin/18" (457mm) ribbon cable & 20 pin breakout

USER INTERFACE

SIT Hand-held user interface
JS Joy Stick

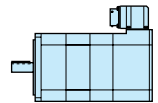

BRUSHLESS

System Ordering

TO ORDER ACTUATORS

B3S/M3S SERIES (SEE PAGE C-30)

B3B/M3B SERIES (SEE PAGE C-50)

TKS SERIES (SEE PAGE C-82)

TKB SERIES (SEE PAGE C-104)

BCS/MCS SERIES (SEE PAGE C-128)

SLS/MLS SERIES (SEE PAGE C-138)

RSA/RSM SERIES (SEE PAGE D-53)

GSA/GSM SERIES (SEE PAGE E-36)

▲ Not all codes listed are compatible with all options.

Use the Tol-O-Motion™ Sizing Software to determine available options and accessories based on your application requirements.

User manuals and software CD-ROM is included with any controller or drive ordered. Manuals and software are also available for download at www.tolomatic.com

Axi dyne® Brushless Servo System

FIELD RETROFIT ORDERING

*SSC 1-4 CONTROLLERS

Code	X-Axis	Y-Axis	Z-Axis	W-Axis	Part #
SSC10	Servo	-	-	-	3600-0210
SSC21	Servo	Stepper	-	-	3600-0221
SSC22	Servo	Servo	-	-	3600-0222
SSC31	Servo	Stepper	Stepper	-	3600-0231
SSC32	Servo	Stepper	Servo	-	3600-0232
SSC33	Servo	Servo	Stepper	-	3600-0233
SSC34	Servo	Servo	Servo	-	3600-0234
SSC41	Servo	Stepper	Stepper	Stepper	3600-0241
SSC42	Servo	Stepper	Stepper	Servo	3600-0242
SSC43	Servo	Stepper	Servo	Stepper	3600-0243
SSC44	Servo	Stepper	Servo	Servo	3600-0244
SSC45	Servo	Servo	Stepper	Stepper	3600-0245
SSC46	Servo	Servo	Stepper	Servo	3600-0246
SSC47	Servo	Servo	Servo	Stepper	3600-0247
SSC48	Servo	Servo	Servo	Servo	3600-0248

NOTE: Any axis of the SSC may be changed by the insertion or removal of a jumper, see SSC manual #3600-4608

*Includes user manual and software CD-ROM

*AXIOM PV CONTROLLER / DRIVE

Config. Code	Includes	Part #
PV10	Controller/Drive (order cables below)	3604-0008
PV20	Controller/Drive (order cables below)	3604-0009
PV30	Controller/Drive (order cables below)	3604-0010

*Includes user manual and software CD-ROM

*AXIOM DV DRIVE

Config. Code	Includes	Part #
DV10	Drive only (order cables below)	3604-0000
DV20	Drive only (order cables below)	3604-0001
DV30	Drive only (order cables below)	3604-0002
DB20	cables are included as motor flying leads	3604-0003

*Includes user manual and software CD-ROM

MRV BRUSHLESS SERVO MOTORS

Config. Code	Part #
MRV11**	3600-6239
MRV21	3600-6240
MRV22	3600-6241
MRV23	3600-6242
MRV24	3600-6243

MRV31	3600-6244
MRV32	3600-6245
MRV33	3600-6246
MRV51	3600-6247

** For RSA Rod Screw Actuators only

USER INTERFACES

Config. Code	Part #
SIT	3600-9161
JS	3600-9162

CABLES

Config Code	Item	Part #
	20 pin breakout	3600-1340
	26 pin breakout	3600-1341
	60 pin breakout	3600-1342
	20 pin ribbon cable	3600-1345
	26 pin ribbon cable	3600-1346
	60 pin ribbon cable	3600-1347
CRZ	RS232 Cable	3600-1172
	SSC Encoder cable	3604-1213
	RS232 - 9 Pin Adapter for MSS/MSD	3600-1186
	RS232 Cable Only for MSS/MSD	3600-1187
CR6 (DV10)	6m Motor Cable	3604-1190
CR6 (DV10)	6m Encoder Cable	3604-1196
CR15 (DV10)	15m Motor Cable	3604-1191
CR15 (DV10)	15m Motor Cable	3604-1197
CR6 (DV20)	6m Motor Cable	3604-1192
CR6 (DV20)	6m Encoder Cable	3604-1196
CR15 (DV20)	15m Motor Cable	3604-1193
CR15 (DV20)	15m Encoder Cable	3604-1197
CR6 (DV30)	6m Motor Cable	3604-1194
CR6 (DV30 & MRV51)	6m Motor Cable	3604-1202
CR6 (DV30)	6m Encoder Cable	3604-1196
CR15 (DV30)	15m Motor Cable	3604-1195
CR15 (DV30 & MRV51)	15m Motor Cable	3604-1203
CR15 (DV30)	15m Encoder Cable	3604-1197

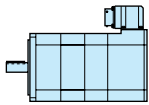

BRUSHLESS

Field Retrofit
Ordering

FIELD RETROFIT ORDERING



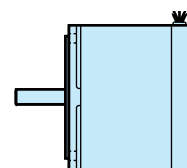

MICROSTEPPING

- **MRS MICROSTEPPING MOTORS**
- **MSD MICROSTEPPING DRIVE**
- **MSS CONTROLLER/DRIVE**
- **SSC CONTROLLER**
- **JS JOYSTICK INTERFACE**
- **SIT HAND-HELD INTERFACE**
- **PIT PANEL MOUNT INTERFACE**

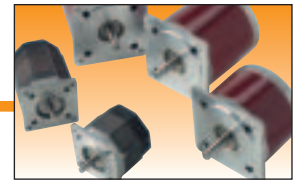

APPLICATION BENEFITS

- Lowest cost for precise positioning
- Highest resolution [up to 50,800 steps- rev] without feedback device
- Good for speeds less than 2,000 rpm
- Good for torque requirements less than 35 in-lbs. (3.95 N-m)
- Smoothness better than full or half step, but not as good as servos
- Good for short, repetitive moves
- Maintenance free

MOTOR



MRS- Stepper Motors

- High torque to inertia ratio
- Long life bearings, high temperature insulation and exceptional thermal dissipation
- NEMA 17, 23 and 34 mounting

DRIVE

MSD - Microstepping Drive

- Step, direction, amplifier enable inputs, fault output, optically isolated
- 16 switch selectable microstepping resolutions
- Idle current reduction (50% switch selectable)

CONTROLLER/DRIVE

MSS - Controller/Drive

- Combines basic single axis controller and drive
- Software uses intuitive icons for setup & programming
- Software selectable: resolutions, motor current
- Two dedicated, optically isolated limit switch inputs, Four general purpose, opto-isolated inputs, CW and CCW jog inputs
- Drive fault output, 3 general purpose, optically isolated outputs

CONTROLLER



SSC Controller:

- Performs any motion task including jogging, point-to-point positioning, linear and circular interpolation, electronic gearing, camming and contouring
- Multitasking feature permits simultaneous execution of four independent applications programs
- Tol-O-Motion SSC Motion Control Software allows setup & programming with easy-to-use Windows[®] interface
- Up to 4 axes per unit - up to 4 units can be daisy-chained
- 4M non-volatile EEPROM memory for executing custom application programs - permits stand-alone operation
- Relative and absolute positioning with more than $\pm 2,000,000,000$ counts per move
- Inputs: opto-isolated dedicated for home, abort, forward and reverse limits, 8 uncommitted; 7 analog inputs
- Outputs: 8 programmable

INTERFACES

PIT - Panel mount interface

- Keypad, LCD display for use with MSS



JS - Joystick

- Use with SSC joystick teach mode

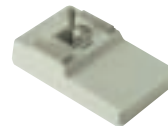

SIT - Hand-held interface

- 45 key - keypad, LCD display
- for use with SSC



Host compatible PC

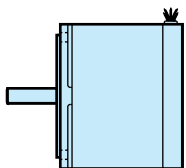

MICROSTEPPING

Overview

Axi-dyne® MRS Microstepping Motors

FEATURES AND SPECIFICATIONS



COMPATIBILITY:
SYSTEM: STEPPER

MOTORS: MRS

DRIVE: MSD
MSS

CONTROLLER: SSC
MSS

INTERFACE: PIT
JS
SIT

The MRS series motors provide the best cost/performance value available in stepper motors. Available with NEMA 17, 23 and 34 mounting, the MRS series stepper motors can be driven from one common microstepping drive (MSD) or controller/drive (MSS).

MRS MOTOR FEATURES

- Long life bearings
- High temperature insulation
- Exceptional thermal dissipation properties
- NEMA 17,23 and 34 mounting
- High torque to inertia ratio

MRS MOTOR SPECIFICATIONS

MODEL	Holding Torque*		Rated Current/Phase** Amps (dc)	Drive Settings*** Max Current/Phase Amps (peak)	Phase Resistance Ohms ±10%	Phase Inductance§ mH	Thermal Resistance§§ °C/Watt	Rotor Inertia		Weight	
	2 Phases ON oz-in (±10%)	N-m						lb-in ²	kg-m ² x 10 ⁻⁶	lbs	kgs
MRS171	35	0.24	1.0	1.4	4.6	8.9	NA	0.011	3.10	0.66	0.29
MRS231	109	0.77	1.5	2.2	2.61	10.3	5.5	0.041	12.07	1.5	0.68
MRS232	203	1.43	2.5	3.6	1.22	6.2	4.5	0.087	25.42	2.5	1.13
MRS341	337	2.37	5.4	5.5	0.29	2.5	3.9	0.201	58.71	3.2	1.45
MRS342	627	4.43	5.6	5.5	0.39	3.7	2.7	0.411	120.17	5.3	2.40
MRS343	995	7.03	7.9	5.5	0.26	3.1	2.0	0.604	176.68	7.6	3.45

* With rated current applied. Windings at 130°C and motor unmounted and in still air at 40°C (without heat sink).

** Windings at 130°C and motor in still air at 40°C (without heat sink). Operation of these motors above rated current may cause demagnetization. Contact factory.

*** When used with the MSS or MSD.

§ Small signal inductance as measured with impedance bridge at 1kHz, 1 amp.

§§ Thermal resistance measured with motor hanging in still air (unmounted).

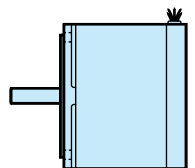

MICROSTEPPING

MRS Motors

- Specifications

Axi *dyne*® MRS Microstepping Motors

PERFORMANCE DATA

WITH MSS CONTROLLER/DRIVE OR MSD DRIVE

MRS171 SPEED TORQUE CURVE

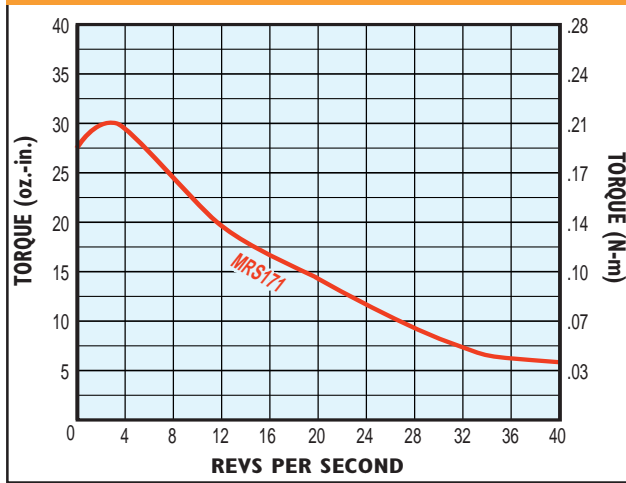

MRS231/232 SPEED TORQUE CURVE

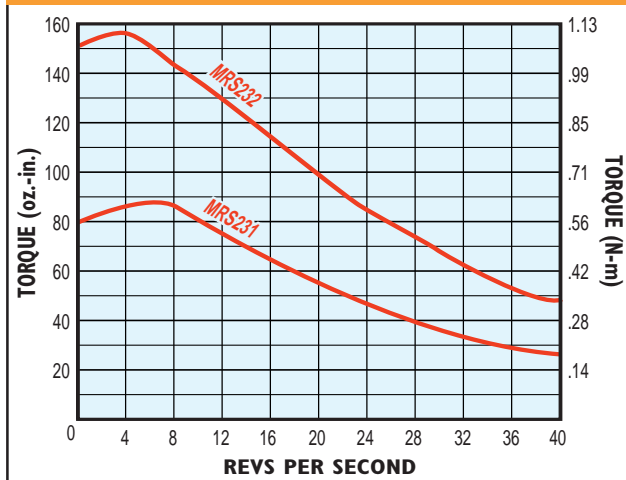

MRS341/342/343 SPEED TORQUE CURVE

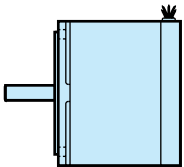
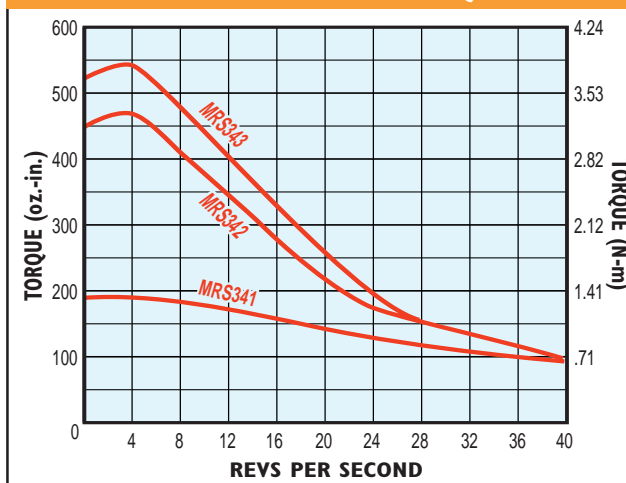

MICROSTEPPING

MRS Motors

- Performance data

Axi-dyne® MRS Microstepping Motors

DIMENSIONS

MRS171

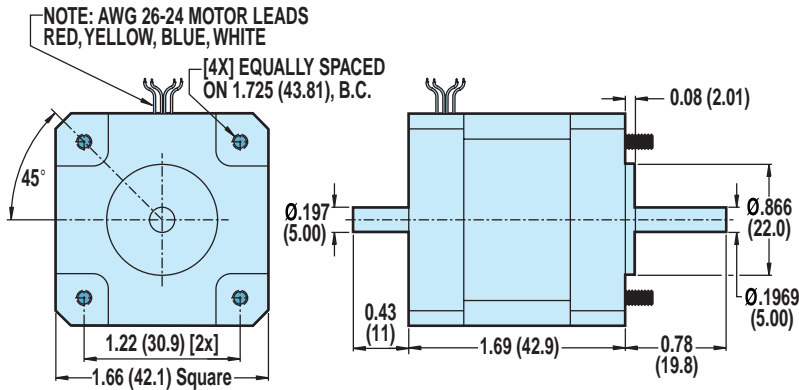

MRS231,232

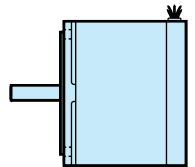
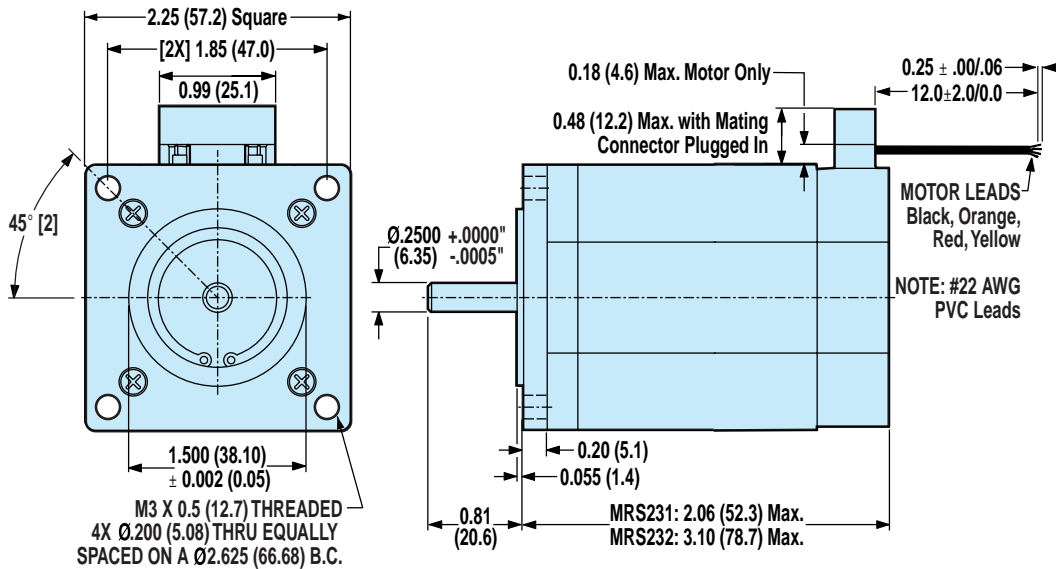

MICROSTEPPING

MRS Motors

- Dimensions

MRS341,342,343

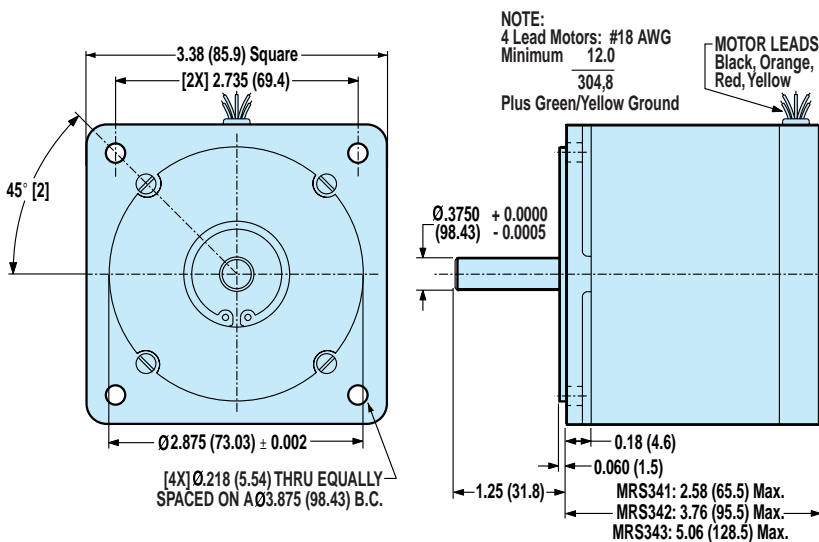

Unless otherwise noted, all dimensions shown are in inches (Dimensions in parenthesis are in millimeters)

Axi-dyne® Gearhead Reduction

SPECIFICATIONS AND DIMENSIONS

- COMPATIBILITY:**
 SYSTEM: BRUSHLESS
 MOTORS: MRV
 ACTUATORS: ALL TOL-O-MATIC SCREW DRIVES
- COMPATIBILITY:**
 SYSTEM: STEPPER
 MOTORS: MRS
 ACTUATORS: ALL TOL-O-MATIC SCREW DRIVES
- COMPATIBILITY:**
 SYSTEM: BRUSHED DC
 MOTORS: MRB
 ACTUATORS: ALL TOL-O-MATIC SCREW DRIVES



⚠ * Reflected inertia is inertia at motor side of gearhead.

For a complete part listing of screw-drive motor and gearhead mounting kits referencing actuator/motor/coupler compatibilities, refer to document 3600-4631 available on the Literature/Axidyne/Part Sheet section of our web site at: www.tolomatic.com.

For those applications requiring reduction for inertia matching or higher torque at lower speeds, Tol-O-Matic offers high efficiency, single stage, true planetary gearheads. Gear ratios of 5.5:1 and 10:1 are available and are compatible with 23- and 34-frame MRV Brushless Servo, MRS Microstepping and Brushed DC motors.

SPECIFICATIONS

Efficiency:	85%
Backlash:	less than 10 arc minutes
Max. Input Speed:	5000 RPM

CONFIG NO.	PART NO.	FRAME SIZE	GEAR RATIO	REFLECTED INERTIA*		INPUT SHAFT DIA. (in)	WEIGHT	
				lb-in ²	kg-m ²		lbs	kgs
GHK20	3600-6150	23	5.5:1	0.0213	6.22	0.250	1.78	0.81
GHK30	3600-6153	34	5.5:1	0.1131	33.09	0.375	4.68	2.12

23- AND 34-FRAME GEARHEADS

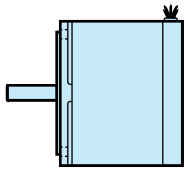

MICROSTEPPING

Gearhead Reduction

- Specifications and Dimensions

23 FRAME GEARHEAD

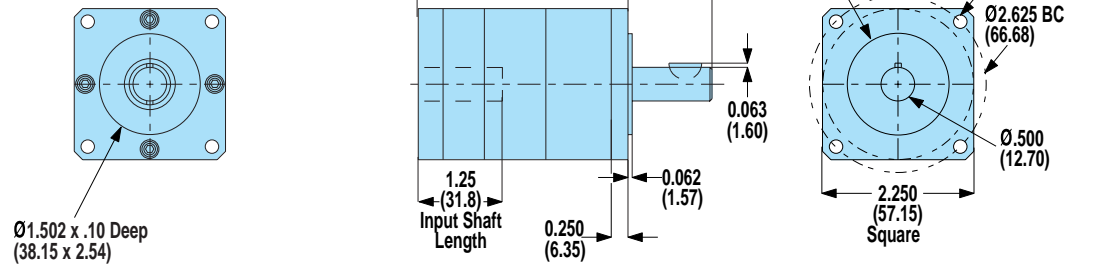

34 FRAME GEARHEAD

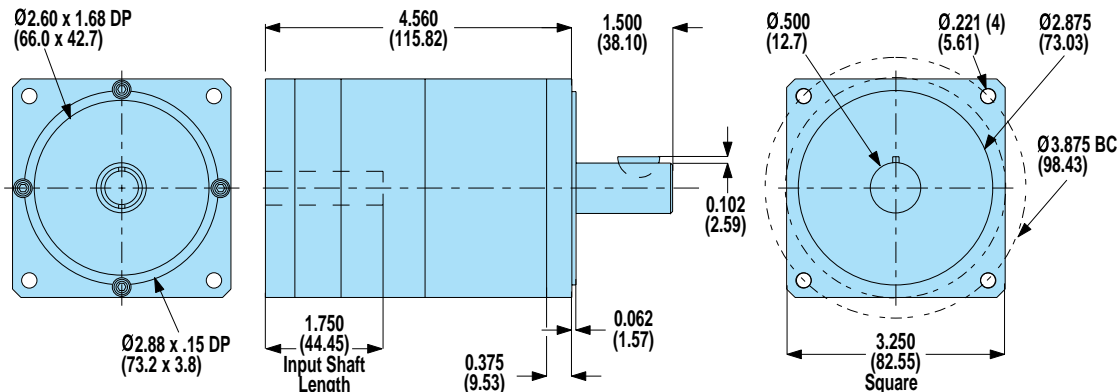

Unless otherwise noted, all dimensions shown are in inches (Dimensions in parenthesis are in millimeters)

Axi dyne® MSD Microstepping Drive

FEATURES

COMPATIBILITY:

SYSTEM: STEPPER

MOTORS: MRS

DRIVE: MSD

CONTROLLER: SSC

INTERFACE: JS

SIT



• CONSIDER THE MSS FOR ALL OF THE FEATURES OF THE MSD, PLUS AN INTEGRAL CONTROLLER, ELIMINATING THE NEED FOR THE SSC CONTROLLER

The MSD, a stand alone microstepping drive, is a low cost solution for use within multi-axis stepper applications. With switch-selectable current settings the MSD is the perfect drive for all of Tol-O-Matic's MRS high torque stepper motors.

MSD FEATURES

- Motor current from 0.5 to 5.5 amps/phase (switch selectable, 51 settings)
- Built-in 80 V power supply (accepts 110 or 220 Vac power)
- MOSFET pulse width modulation switching amplifiers (3 state)
- Step, direction, amplifier enable inputs, fault output, optically isolated
- 2 MHz max input frequency
- 16 switch selectable microstepping resolutions: 200, 400, 1000, 2000, 5000, 10000, 12800, 18000, 20000, 21600, 25000, 25400, 25600, 36000, 50000, 50800, steps/rev
- Over-temperature protection
- Short circuit protection
- Surge protection
- Idle current reduction (50% switch selectable)
- Pluggable screw terminal connectors, mating connectors included
- Integral heat sink
- Digital oscillator provides smooth accel/decel ramps and precise speed control
- Oscillator Mode operates from internal pots, external pots, 0-5V dc analog signal, or analog joystick
- Two speed ranges, can be selected "on-the-fly" by a digital signal with automatic ramping between speeds
- Tach Out signal allows easy measurement of speed
- Enable input allows motor current to be shut off on command
- Built-in self test for troubleshooting
- CE compliant

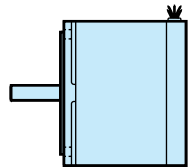

MICROSTEPPING

MSD Drive

- Features

Axi dyne[®] MSD Microstepping Drive

SPECIFICATIONS

MSD SPECIFICATIONS

Power	
Input Voltages (AC line):	110 or 220 Vac, 60Hz (switch selected) 400 W max (a 50/60Hz version can be special ordered)
Dc Bus Voltage):	75 Vdc full load, 90 Vdc no load
Amplifiers	
Pulse Width Modulated:	Dual, MOSFET H-bridge, 3 state at 20 kHz
Switching:	
Phase Peak:	0.5 - 5.5 Amps
Output Current:	
Output Power:	400 watts max
Protection:	Overcurrent and over-temperature
Automatic Idle Current Reduction:	Reduces current to 50% of setting after one second (can be disabled)
Inputs	
Step, Direction & Enable:	Optically isolated differential 5-12V logic
Input Current:	5 mA minimum, 20 mA maximum
Motor Steps	on falling edge of step input
Minimum Pulse	1 μ sec
Maximum Step Rate	2 MHz
Minimum Set Up Time:	1 μ sec
Directional Signal	50 μ s
Minimum Hold Time:	
Fault Output	
Photo Transistor:	Optically isolated, uncommitted (open collector, open emitter)
Voltage:	30V max.
Current:	20 mA max.
Environment	
Max Case Temperature:	158° F (70° C)

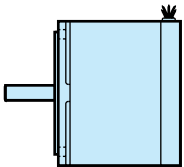

MICROSTEPPING

MSD Drive

- Specifications

Axi-dyne® MSD Microstepping Drive

DIMENSIONS

MSD MICROSTEPPING DRIVE

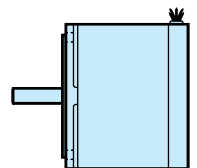
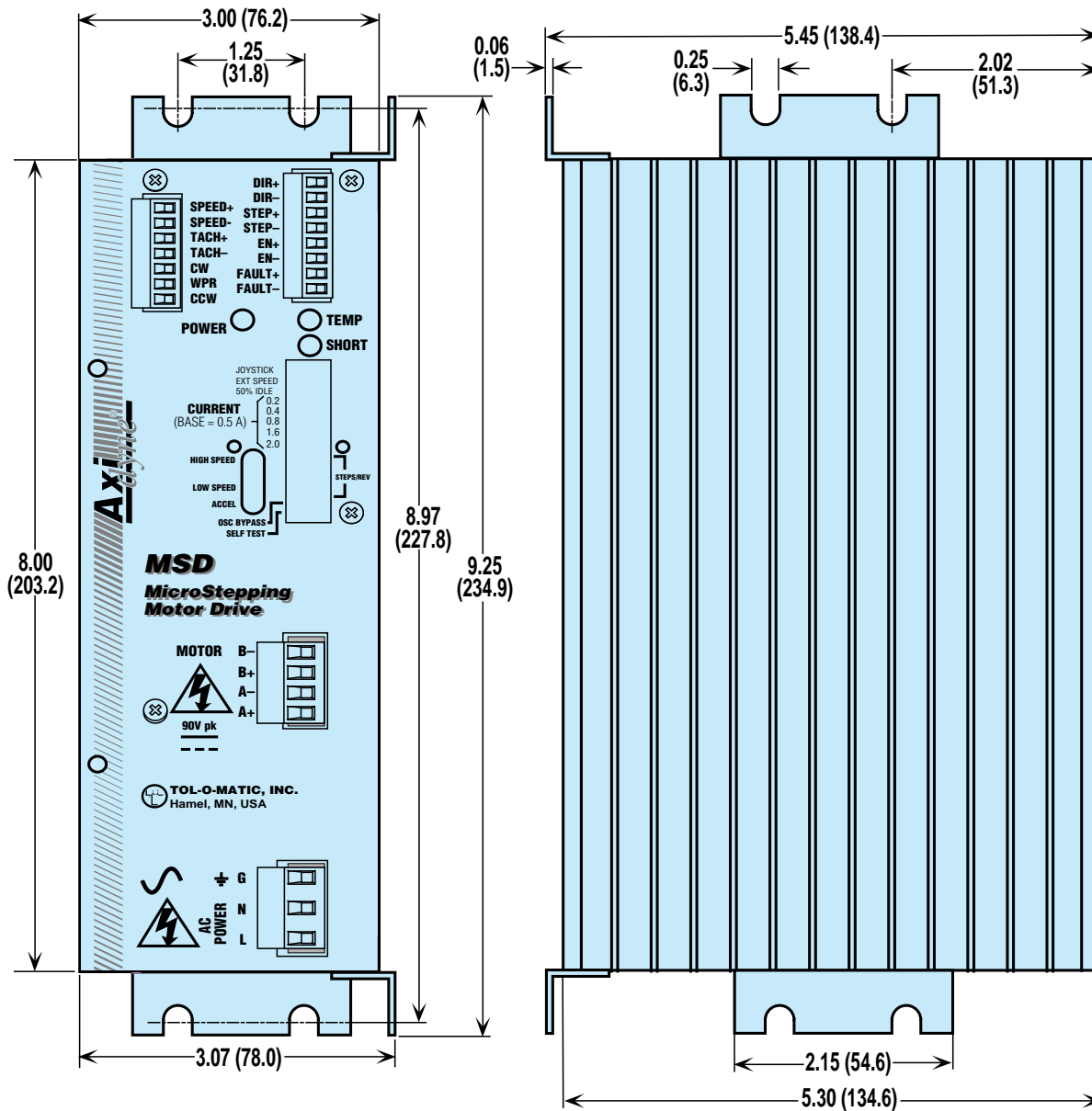

MICROSTEPPING

MSD Drive

- Dimensions

Unless otherwise noted, all dimensions shown are in inches (Dimensions in parenthesis are in millimeters)

Axi-dyne[®] MSS Microstepping Controller/Drive

FEATURES / SPECIFICATIONS



Tol-O-Matic's MSS stand-alone microstepping controller/drive system is absolutely the simplest and most cost-effective way to provide single axis motion to Tol-O-Matic's stepper motor/actuator systems. The Tol-O-Motion™ MSS software allows sophisticated programming to be achieved by even the most novice user, through icons arranged in a simple, easy to follow format. Once programmed over the RS232 the PC may be removed and program interaction achieved through I/O or the PIT (Panel Mount User Interface).

COMPATIBILITY:
 SYSTEM: STEPPER
 MOTORS: MRS
 DRIVE: MSD
 MSS
 CONTROLLER: MSS
 INTERFACE: PIT

MSS FEATURES

- Motor Current: 0.5 to 5.5 amps/phase, (software selectable)
- Drive Voltage: 80 Vdc (from internal linear, toroidal power supply)
- Input Voltage: 115 or 230 Vac (switch selectable)
- Microstep Resolution: 13 resolutions, 2000 to 50800 steps/revolution (software selectable)
- Automatic idle current reduction: 0%, 25%, 50% or 100% (software selectable)
- Connectors: pluggable, screw terminal connectors are included.
- Two optically isolated limit switch inputs can be used as inputs, (7 - 8)
- CW and CCW jog inputs can be used as inputs, (5 - 6)
- Four general purpose, opto-isolated inputs
- Drive fault output (activated by overcurrent or over-temperature condition)
- 3 general purpose, optically isolated outputs for interfacing to other equipment
- Uses Tol-O-Motion MSS Software with absolute positioning, single-step program execution
- CE compliant

MSS SPECIFICATIONS

Power	
Input Current (AC line):	Varies with motor & load
	6.0A max. at 115 Vac
Input Voltages (AC line):	115 or 230 Vac, 50-60Hz (switch selected)
Input Fuses	
(AC line):	6.3A time lag, TR5 style
Motor Current Output:	0.5 - 5.5 A / phase peak
Internal Bus Voltage:	80 Vdc (unregulated)
Parameter Ranges	
Distance:	1 to 16,000,000 steps
Speed:	.025 to 50 revolutions per second (in any microstep resolution)
Acceleration:	1 to 3000 rev/sec/sec (limited by accel torque)
Deceleration:	1 to 3000 rev/sec/sec (set independently from acceleration, limited by decel torque)
Time Delays:	0.1 to 25.5 seconds
Microstep Resolution:	2000-50800 steps/rev
Inputs*	
Input 1-4, Optically isolated,	5 - 24 Vdc, 20 mA max
CW Jog, CCW Jog:	2200 Ohms internal resistance
CW Limit, can be configured for	sinking (NPN)
CCW Limit:	or sourcing (PNP) signals.
Outputs*	
Outputs 1-3:	Optically isolated, 24 Vdc max, 100mA
Environment	
Maximum Case Temp.:	167° F (75° C)
Ambient Temp. Range:	32° to 113° F (0 to 45° C)

* NOTE: External 5-24 Vdc power supply required for operation.

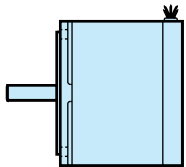

MICROSTEPPING

MSS Controller/Drive

- Features
- Specifications

Axi-dyne[®] MSS Microstepping Controller/Drive

PROGRAMMING

MSS PROGRAMMING SOFTWARE



Main Programming Screen

Programmable by RS232 connection to a PC running Windows 95, 98, NT, 2000 or XP. Programming software and cable included. Programming is very easy to learn and requires no previous programming experience.

Programs can be up to 100 lines long. Instructions are powerful, so 100 lines can provide the user with a sophisticated program. For example, in one program line the motor can be moved until a sensor changes state, then fed a precise distance to stop, delayed and returned to the starting point. Distances, delays, feed and return speeds, acceleration and deceleration parameters are all included in the single program instruction. The same move can take 10 program lines or more on other indexers. There are a total of 16 different instructions, including input/output, branches, loops and motion commands. These instructions can be combined to make a nearly infinite variety of programs, meeting the demands of a wide range of applications.

The main programming screen is shown above. On the right of the screen are the 100 program lines. In the center are command buttons and on the left are global parameters such as microstep resolution and jog. Clicking on a program step icon brings up a sequence of dialog boxes, making program selection and parameter setting easy.

Once programmed, the cable can be removed and the indexer-drive will run stand alone. Programs and parameters are stored internally in non-volatile memory. Upon power up, the drive automatically senses the connection to the Windows programming software. If no connection is detected, the program is automatically executed starting on line 1.

The MSS also allows program interaction to take place using the PIT user interface.

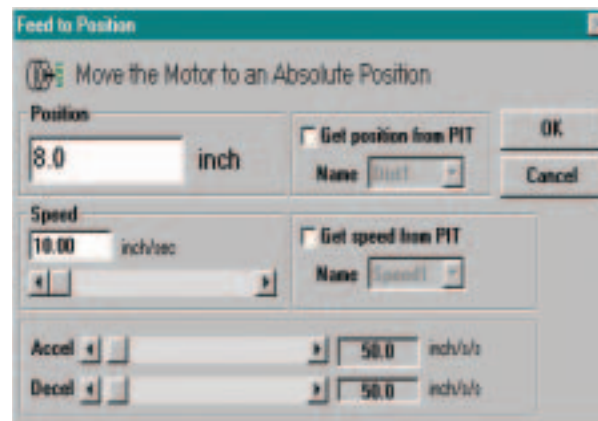

Dialog box for setting Feed to position

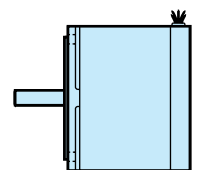

MICROSTEPPING

MSS Controller/Drive

- Programming

Axi dyne[®] MSS Microstepping Controller/Drive

DIMENSIONS

MSS MICROSTEPPING CONTROLLER/DRIVE

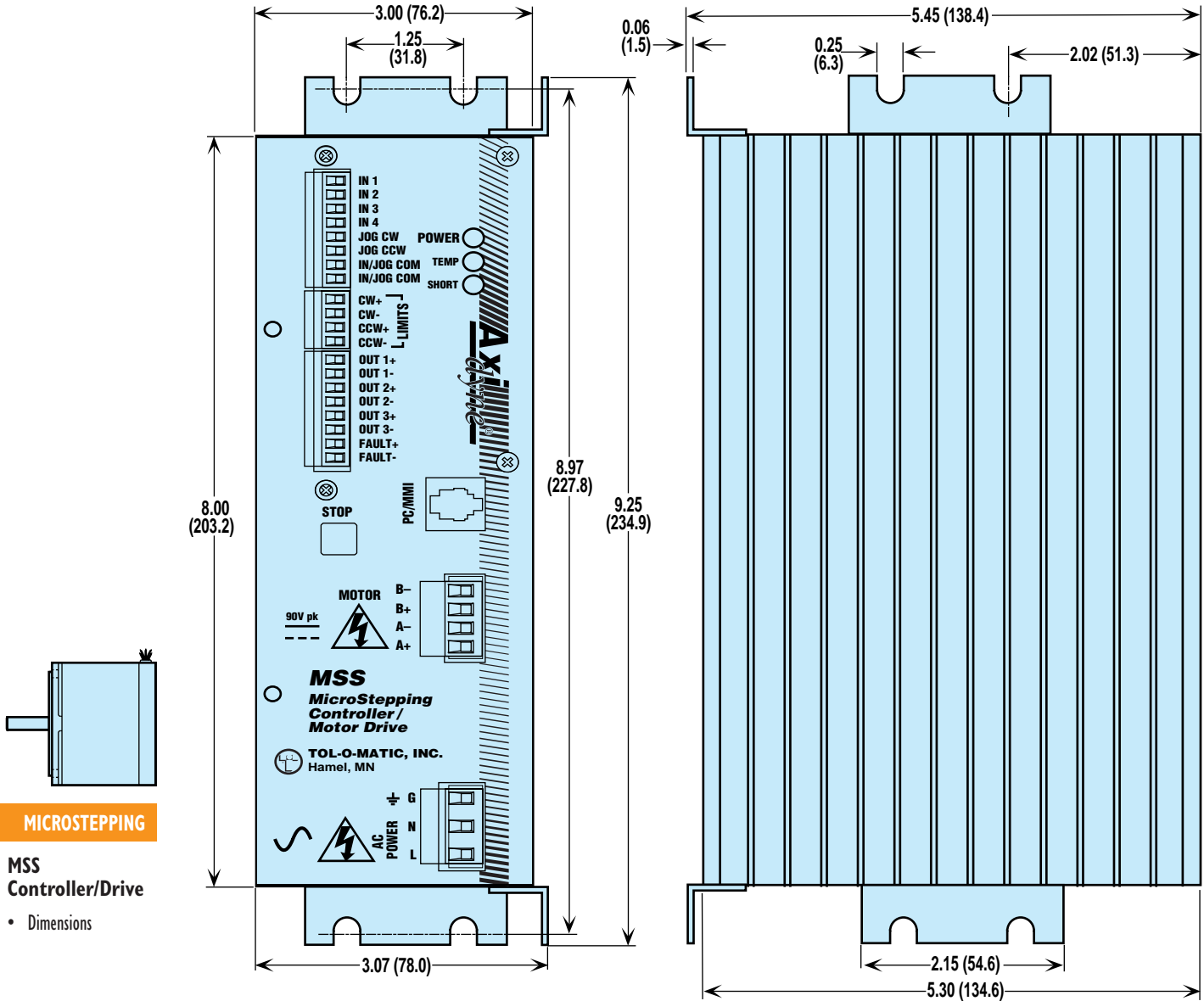

MICROSTEPPING

MSS Controller/Drive

- Dimensions

Unless otherwise noted, all dimensions shown are in inches (Dimensions in parenthesis are in millimeters)

Axi-dyne® SSC Multi-axis Servo/Stepper Controller

FEATURES

COMPATIBILITY:

SYSTEM: BRUSHLESS

MOTORS: MRV

DRIVE: AXIOM DV

CONTROLLER: SSC

INTERFACE: JS
SIT

COMPATIBILITY:

SYSTEM: STEPPER

MOTORS: MRS

DRIVE: MSD

CONTROLLER: SSC

INTERFACE: JS
SIT

COMPATIBILITY:

SYSTEM: BRUSHED DC

MOTORS: MRB

DRIVE: AXIOM DB

CONTROLLER: SSC

INTERFACE: JS
SIT



The SSC is a high-performance, state-of-the-art motion controller designed for stand-alone operation. This cost effective controller uses a 32-bit microprocessor, a sub-micron gate array, and Tol-O-Motion SSC software, to provide DSP performance without sacrificing ease of use.

Available with up to 4 axes per unit, purchase only the number of axes required. It can simultaneously control stepper and /or servo systems.

Designed to solve complex motion problems with superior precision, the SSC can be used for applications requiring jogging, vector positioning of multi-axis, 2-dimensional linear or circular interpolation, contouring and electronic gearing.

With the Tol-O-Motion SSC software there is no need to learn programming language. Complex motion control is made easy with an interface that streamlines the entire programming process from setup to execution.

SSC FEATURES

- High performance motion control packaged in an industrial enclosure
- Uses a 32-bit specialized microcomputer and custom, submicron gate array for highest performance and speed
- Up to 4 axes per unit — up to 8 units can be daisy-chained
- 125 µsec per axis servo update rate for high bandwidth
- Controls servo motors and/or step motors
- Sophisticated PID filter with velocity and acceleration feed forward for optimum precision
- 16 bit DAC for fine resolution control
- 256K RAM memory for holding and running active program up to 1000 lines x 80 characters
- 4M EEPROM memory for non volatile storage of custom application programs, parameters and arrays (8000 array elements x 30 arrays) — permits stand-alone operation
- Multitasking feature permits simultaneous execution of four independent applications programs
- Programmable acceleration and deceleration with profile smoothing to eliminate jerk
- Continuous vector feed of infinite number of linear and arc segments for smooth motion
- Selectable linear scale simplifies linear motion programming
- Contour mode for profiling along computer generated paths such as parabolic or spherical profiles
- Performs any motion task including jogging, point-to-point positioning, linear and circular interpolation, electronic gearing, cam and contouring
- Dedicated opto-isolated inputs for home, abort, forward and reverse limits — noise immune
- Position feedback for each axis can be from analog signal or encoder
- Auxiliary encoder inputs and dual-loop damping — ideal for backlash compensation
- Programmable event triggers for monitoring elapsed time, position, speed, and motion complete
- I/O functions, timers, and logic functions for executing PLC tasks
- 254 symbolic variables and 8000 element array space for data storage
- Internal, universal switching power supply for direct connection to AC outlet (115V or 230V)
- IDC connectors on front panel connect to DIN rail mounted screw terminal breakouts included
- Additional I/O available on request

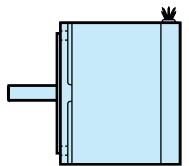

MICROSTEPPING

SSC Multi-axis Servo/Stepper Controller

- Features

Axi-dyne® SSC Multi-axis Servo/Stepper Controller

SPECIFICATIONS

SSC SPECIFICATIONS

Performance

Servo Loop Cycle Time:	SSC 1: 250 μ sec; SSC 2: 375 μ sec SSC 3: 500 μ sec; SSC 4: 500 μ sec
Block Execution Time:	In contour mode, up to 1000 blocks (moves)/sec with full trajectory calculation
Position Accuracy:	± 1 quadrature count
Velocity Accuracy:	Long-term: phase-locked, better than 0.003% Short-term: system dependent
Synchronization:	All axes in the same unit are perfectly synchronized and share the same servo cycle.
Position Capture Accuracy:	25 μ sec with opto-isolation; 1 μ sec if by-pass opto-isolation.

Parameter Ranges

Position Range:	$\pm 2,147,483,647$ counts/move; automatic rollover; no limit in jog or vector modes.
Velocity Range:	Up to 8,000,000 counts/sec
Acceleration/deceleration:	1,024 to 67,107,840 c/sec ²
Error Limit:	$\pm 32,767$ counts
Gear Ratio:	± 127.9999
Filter Constants:	Kp: 0 to 1023.875 Kd: 0 to 4095.875 Ki: 0 to 2047.875
Motor Command Resolution:	16-bits or .0003 V
Step Motor Control Mode:	Full, half or microstep
Step Pulse Frequency:	2,000,000 pulse/sec
Number of Variables:	254
Array Memory Size:	8000 elements in up to 30 arrays
Program Memory Size:	1000 lines x 80 characters

Mechanical

Dimensions:	13" high x 2.5" wide x 6.6" deep
Weight:	6 lbs.

Inputs/Outputs

Feedback: Two channels of A/B quadrature per axis with third channel for index. In servo mode, includes auxiliary encoder inputs for each axis. Single ended or differential. Can be configured for quadrature, pulse and direction, or from analog inputs.

General Purpose Inputs:	8 opto-isolated inputs
General Purpose Outputs:	8 TTL outputs
General Purpose Analog Inputs:	7, ± 10 V; 12-bit resolution (16-bit optional)
Dedicated Inputs per Axis:	Forward and reverse limits, home.
Dedicated Outputs per Axis:	Analog motor command, pulse and direction, amplifier enable

Available Power to Drive External Devices

+5 V	1.5 Amp	+12 V	750 mA	-12 V	200 mA
------	---------	-------	--------	-------	--------

Environment

Operating Temperature: 32° to 158° F (0° to 70° C)

Communication Interface

Selectable Baud Rate: 300, 1200, 4800, 9600, 19200, 38400.
Handshake mode available.

I/O Description (Inputs)

Encoder, A+, B+:	Position feedback from incremental encoder with two channels in quadrature. The encoder can be (± 12 V) or TTL. Note: Encoders that produce output in a pulse and direction format can also be used.
Encoder Index I+:	Once-per-revolution encoder pulse; used in Homing sequence or Find Index command. Minimum index pulse width is 120 nsec.
Encoder, A-, B-, I-:	Optional differential inputs from encoder; used for enhanced noise immunity.
Auxiliary Encoder:	Inputs for additional encoder; used when encoders on both the motor and the load are required.
Abort #:	Stops commanded motion instantly and also aborts application program.
Reset #:	System reset.
Forward and Reverse Limit Switch #:	When active, inhibits motion in forward or reverse direction and also causes the limit switch subroutine #LIMSWI to execute.
Home Switch #:	Input for Homing (HM) and Find Edge (FE) instructions.
Input 1 - Input 8#:	Uncommitted inputs; can be defined by the user to trigger events or interrupt program.
Latch#:	High-speed position latch to capture axis position within 25 μ sec (bypass opto-isolation for .1 μ sec capture). AL command arms latch. Input 1, 2, 3, 4 latches X, Y, Z, W respectively.
Analog 1 - Analog 7:	Analog inputs that can be connected to external analog signals such as force or pressure transducers. Can also be used for position feedback. 12-bit resolution ADC for ± 10 V input.

I/O Description (Outputs)

Analog Motor Command:	± 10 V range signal for driving servo amplifiers; 16-bit resolution or .0003 V, 3 mA.
Amp enable:	Signal to disable and enable an amplifier. Amp enable goes low when a motor-off condition occurs. For step motors, this pin provides for reduced current when low.
Step Out:	Pulses for input to a step motor driver. The pulses can be either active low or high. Upon Reset, the output will be low if the SM jumper is on, Tristate if off. The STEP OUT pin also provides the PWM signal for servo motors.
Direction:	Used with the STEP OUT signal to give direction to step motors or servo motors in the sign magnitude mode.
Error:	The signal goes low when the position error on any axis exceeds the limit specified by the error command, ER.
Output 1 - Output 8:	These 8 TTL outputs are uncommitted and can be designated by the user to toggle relays and trigger external events. The output lines are toggled by Set Bit (SB), Clear Bit (CB), Define Bit (DB), and OP instructions. Upon reset these signals will be low.

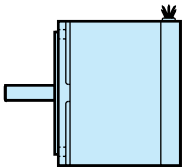

MICROSTEPPING

SSC Multi-axis Servo/Stepper Controller

- Specifications

CONNECTORS

SSC CONNECTORS

SSC J2 Main; 60-Pin IDC;

1 Ground	2 5V		
3 Error	4 Reset		
5 Switch Common	6 Forward Limit - X		
7 Reverse Limit - X	8 Home - X		
9 Forward Limit - Y	10 Reverse Limit - Y		
11 Home - Y	12 Forward Limit - Z		
13 Reverse Limit - Z	14 Home - Z		
15 Forward Limit - W	16 Reverse Limit - W		
17 Home - W	18 Output 1		
19 Input Common	20 Latch X or Input 1		
21 Latch Y or Input 2	22 Latch Z or Input 3		
23 Latch W or Input 4	24 Abort Input		
25 Motor Command X	26 Amp Enable X		
27 Motor Command Y	28 Amp Enable Y		
29 Motor Command Z	30 Amp Enable Z		
31 Motor Command W	32 Amp Enable W		
33 A+ X	34 A- X	35 B+ X	36 B- X
37 I+ X	38 I- X	39 A+ Y	40 A- Y
41 B+ Y	42 B- Y	43 I+ Y	44 I- Y
45 A+ Z	46 A- Z	47 B+ Z	48 B- Z
49 I+ Z	50 I- Z	51 A+ W	52 A- W
53 B+ W	54 B- W	55 I+ W	56 I- W
57 +12V	58 -12V	59 5V	60 Ground

SSC J5 General I/O; 26-Pin IDC;

1 Analog 1	2 Analog 2
3 Analog 3	4 Analog 4
5 Analog 5	6 Analog 6
7 Analog 7	8 Ground
9 5V	10 Output 1
11 Output 2	12 Output 3
13 Output 4	14 Output 5
15 Output 6	16 Output 7
17 Output 8	18 Input 8
19 Input 7	20 Input 6
21 Input 5	22 Input 4 (Latch W)
23 Input 3 (Latch W)	24 Input 2 (Latch W)
25 Input 1 (Latch W)	26 Input Common (Isolated 5V)

SSC J3 Auxiliary Encoder; 20-Pin IDC;

1 Sample Clock	2 Reserved
3 B- Aux W	4 B+ Aux W
5 A- Aux W	6 A+ Aux W
7 B- Aux Z	8 B+ Aux Z
9 A- Aux Z	10 A+ Aux Z
11 B- Aux Y	12 B+ Aux Y
13 A- Aux Y	14 A+ Aux Y
15 B- Aux X	16 B+ Aux X
17 A- Aux X	18 A+ Aux X
19 5V	20 Ground

SSC J4 Driver; 20-Pin IDC;

1 Motor Command X	2 Amp Enable X
3 PWM X/Step X	4 Sign X/Dir X
5	6 Motor Command Y
7 Amp Enable Y	8 PWM Y/Step Y
9 Sign Y/Dir Y	10
11 Motor Command Z	12 Amp Enable Z
13 PWM Z/Step Z	14 Sign Z/Dir Z
15 5V	16 Motor Command W
17 Amp Enable W	18 PWM W/Step W
19 Sign W/Dir W	20 Ground

AC Power INputs; 4-PIN Detachable Screw Type:

Hot Connects to 110 or 220 AC	
NC	No Connect
Neutral	Return for AC
Earth	Chassis input

RS232 - Main Port; 9-PIN:

1 CTS - output	2 Transmit data
3 Receive data	4 RTS - input
5 Ground	6 CTS - output
7 RTS - input	8 CTS - output
9 5V	

RS232 - Auxiliary Port; 9-PIN:

1 CTS - input	2 Receive data -
3 Transmit data	4 RTS - output
5 Ground	6 CTS - input
7 RTS - output	8 CTS - input
9 5V	

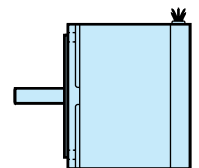

MICROSTEPPING

SSC Multi-axis Servo/Stepper Controller

- Connectors

Axi-dyne[®] SSC Multi-axis Servo/Stepper Controller

PROGRAMMING SOFTWARE

SSC PROGRAMMING SOFTWARE

Programming is accomplished through RS232 connection to a PC running Windows 95, 98, NT, 2000 or XP. Visual Basic panels guide the user through the complete setup process including communications and axis configuration. The user can then use other program options including Display, Jog, Teach, Programmer, Tune and Data Acquisition.

Display

The Display panel (shown above) allows the user to identify axis locations and status faults, limits, and I/O.

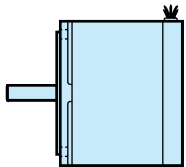
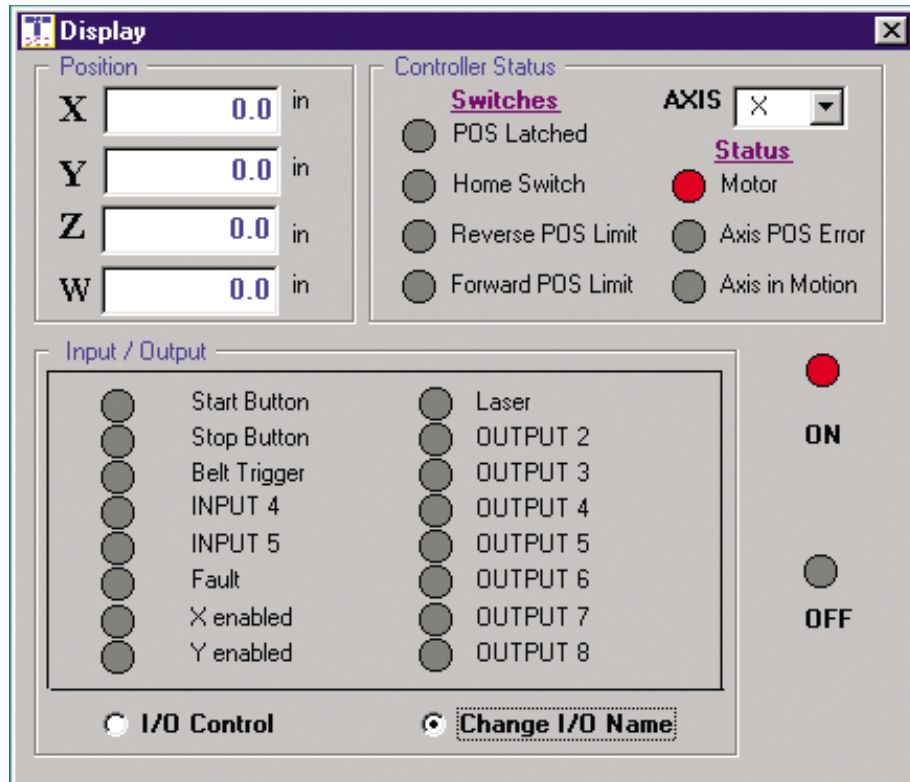

MICROSTEPPING

SSC Multi-axis Servo/Stepper Controller

- Programming

Jog

The Jog panels allow the user to easily setup independent motion or coordinated motion.



Axi dyne[®] SSC Multi-axis Servo/Stepper Controller PROGRAMMING SOFTWARE

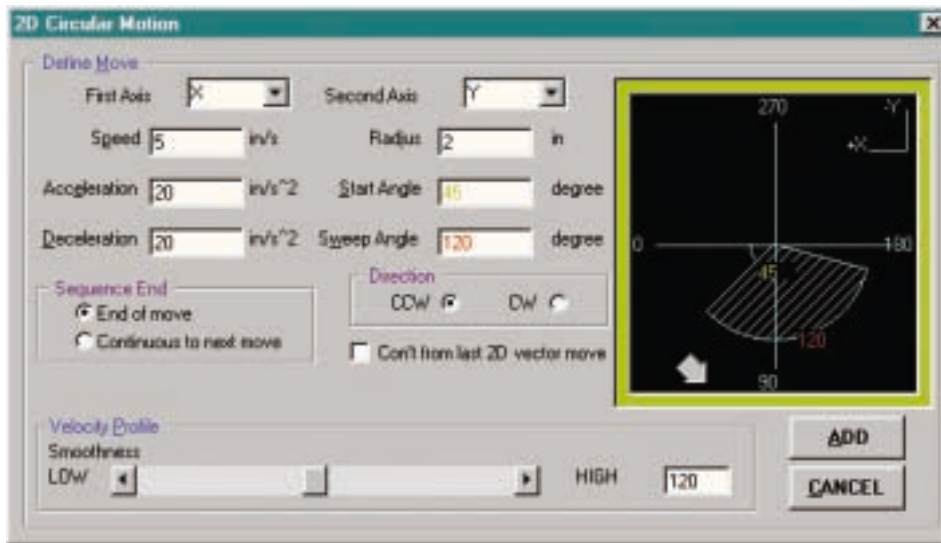

CIRCULAR MOTION

The added feature of 2-dimensional circular programming, assists you in selecting start and sweep angles.

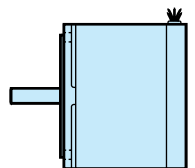

MICROSTEPPING

SSC Multi-axis Servo/Stepper Controller

- Programming

Axi-dyne[®] SSC Multi-axis Servo/Stepper Controller

DIMENSIONS

SSC (MULTI-AXIS SERVO/STEPPER CONTROLLER)

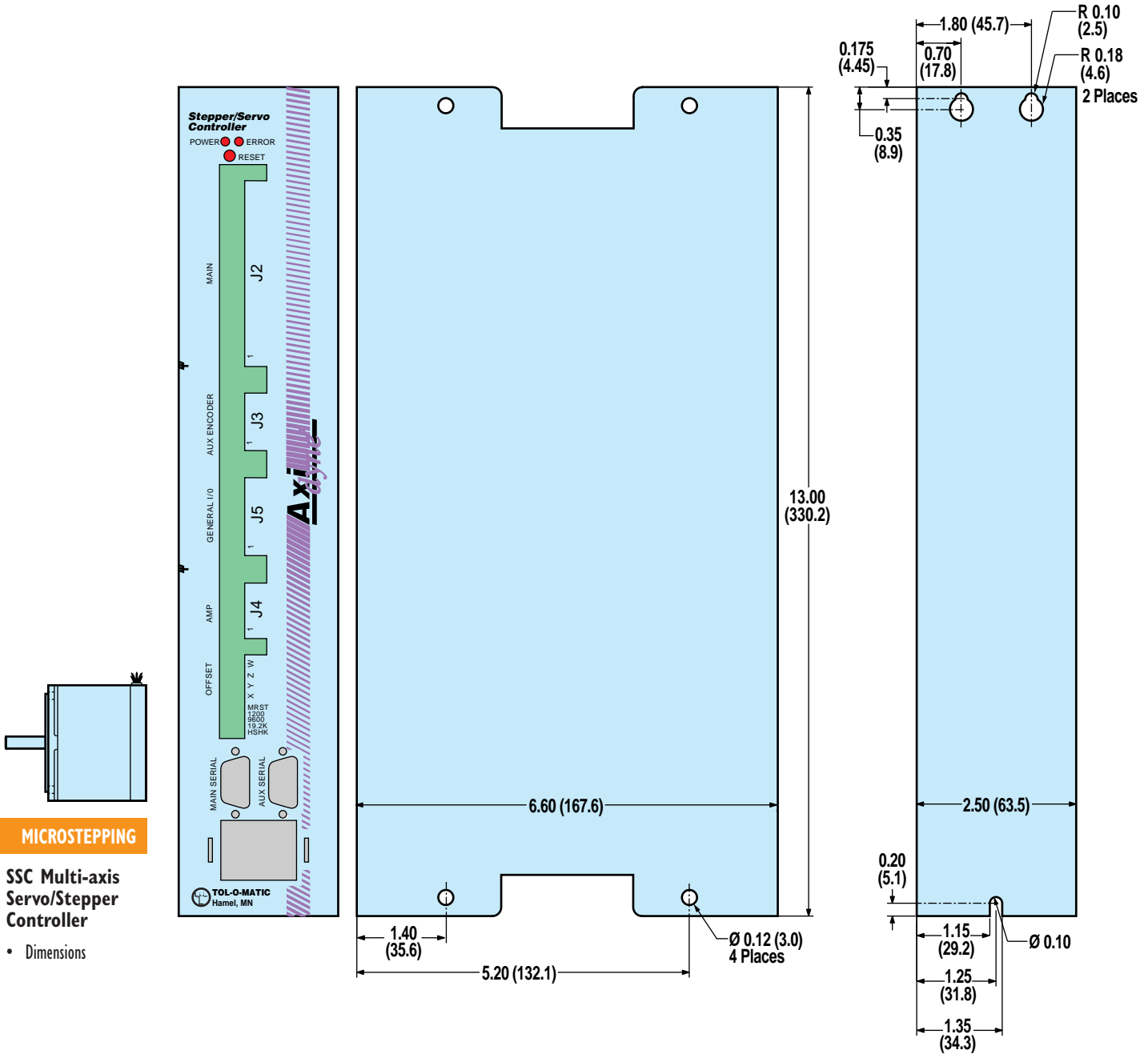

MICROSTEPPING

SSC Multi-axis Servo/Stepper Controller

- Dimensions

Unless otherwise noted, all dimensions shown are in inches (Dimensions in parenthesis are in millimeters)

SPECIFICATIONS AND DIMENSIONS

COMPATIBILITY:

SYSTEM: STEPPER
 MOTORS: MRS
 DRIVE: MSS
 CONTROLLER: MSS
 INTERFACE: PIT

COMPATIBILITY:

SYSTEM: BRUSHED DC
 MOTORS: MRB
 DRIVE: AXIOM DB
 CONTROLLER: MSC
 INTERFACE: PIT



User interaction with the MSS is simple with the PIT panel mount user interface. The Tol-O-Motion MS software allows visual setup of the panel to status the user on a particular action taking place, or to prompt the user to make a decision or provide information such as move distance, move speed, repeat count.

FEATURES

- Flush or surface mounting
- Four line by 20 character LCD display
- RS232 communication to MSS controllers
- Uses RS232 cable supplied with MSS controllers

CABLES

Motor cable and encoder cable are included when ordering MSS controllers (see page G-23)

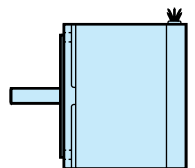

PIT (PANEL MOUNT USER INTERFACE) DIMENSIONS

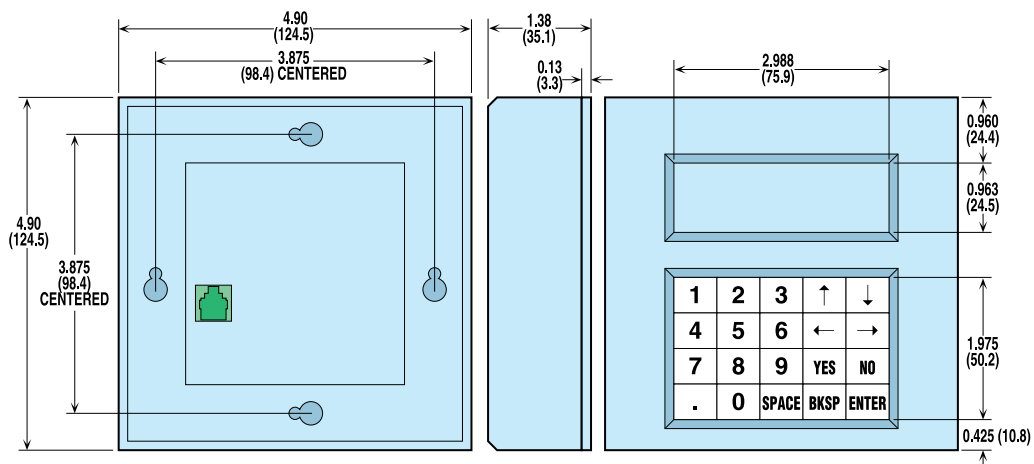

Unless otherwise noted, all dimensions shown are in inches (Dimensions in parenthesis are in millimeters)

MICROSTEPPING

PIT Panel Mount User Interface

- Features
- Dimensions

Axi-dyne® JS – Joystick User Interface

SPECIFICATIONS AND DIMENSIONS

COMPATIBILITY:
 SYSTEM: BRUSHLESS
 MOTORS: MRV
 DRIVE: AXIOM DV
 CONTROLLER: SSC

INTERFACE: JS
 SIT

COMPATIBILITY:
 SYSTEM: STEPPER
 MOTORS: MRS
 DRIVE: MSD
 CONTROLLER: SSC

INTERFACE: JS
 SIT

COMPATIBILITY:
 SYSTEM: BRUSHED DC
 MOTORS: MRB
 DRIVE: AXIOM DB
 CONTROLLER: SSC

INTERFACE: JS
 SIT



For simple setup of the SSC controller the JS joystick provides 2-axis manipulation. Used with the Joystick Teach mode of the Tol-O-Motion SSC software, moves can be made with velocity control, and then stored using a separate button integrated into the joystick housing.

SPECIFICATIONS	JS Joystick
Joystick Travel	27° from design center in all directions
Mechanical Life Cycle	5 million (minimum)
Trim Movement (Optional)	±7° (total trim 14°) for each axis
Main Ball Pivot	Precision ground stainless steel
Stick Shaft	3/16" brass plated
Potentiometers	Set at center of resistance
Potentiometer Calibration	Thumb tab provides up to 114° of potentiometer calibration
Return to Center Repeatability	±1%
Deflection Force	0.14 lbs. at 27° at 2-7/8" from pivot point
Switches	2 elongated push-button switches
Cable	Integrated 7' (2.1m) cable with strain relief

JS (JOYSTICK) DIMENSIONS

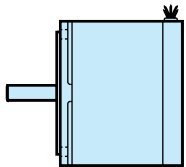

MICROSTEPPING

Js Joystic User Interface

- Specifications
- Dimensions

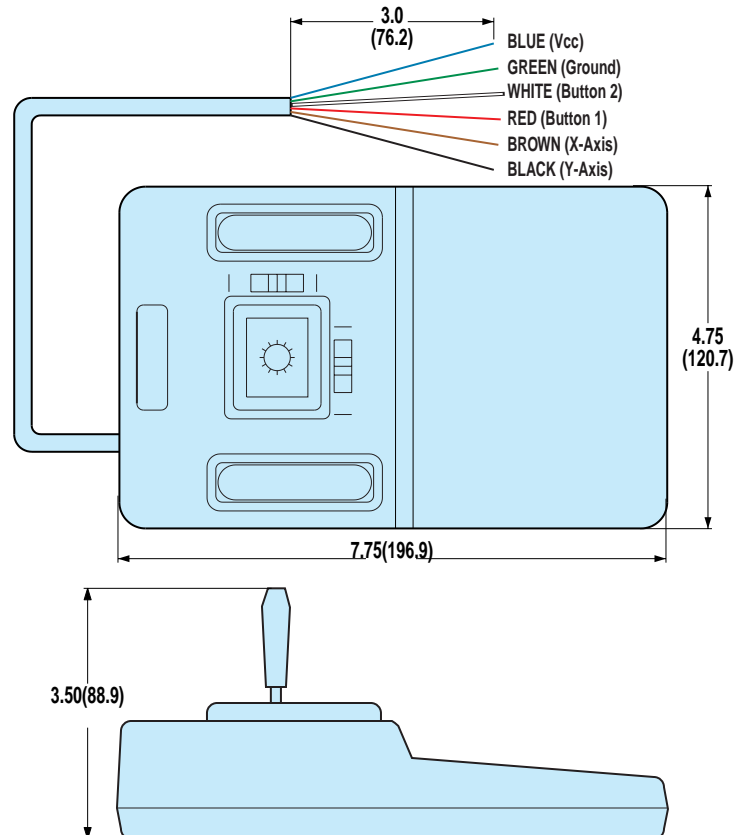

Unless otherwise noted, all dimensions shown are in inches (Dimensions in parenthesis are in millimeters)

Axi-dyne® SIT – Hand-held User interface

FEATURES, SPECIFICATIONS AND DIMENSIONS

COMPATIBILITY:

SYSTEM: BRUSHLESS
 MOTORS: MRV
 DRIVE: AXIOM DV
 CONTROLLER: SSC
 INTERFACE: JS
 SIT

COMPATIBILITY:

SYSTEM: STEPPER
 MOTORS: MRS
 DRIVE: MSD
 CONTROLLER: SSC
 INTERFACE: JS
 SIT

COMPATIBILITY:

SYSTEM: BRUSHED DC
 MOTORS: MRB
 DRIVE: AXIOM DB
 CONTROLLER: SSC
 INTERFACE: JS
 SIT



For user interaction with the SSC 1-4 axis multi-function controllers the SIT hand held user interface provides flexibility and setup simplicity. The Tol-O-Motion SS software (included with the SSC 1-4 controllers) has a setup page for use with the SIT to allow the controller to status the user, or to prompt the user for information, eliminating the need for a PC following setup.

FEATURES:

- 45 key, alpha-numeric tactile keypad
- 4 row by 20 character LCD display
- Rugged, high impact ABS housing
- 7 foot (2.1m) RS232 cable with 9-pin “D” connector for connection to the SSC 1-4
- 5 Vdc power supplied from SSC 1-4 controller over RS232

SPECIFICATIONS JS Joystick

Weight	8.0 oz. (.23 Kg.)
Character Set	ASCII with upper case transmit, upper and lower case receive
Case	Molded, high impact ABS with retractable hanger
Keypad	15 user-programmable function keys
Display	Transreflective LCD with 5 by 7 character font
Power Requirements	30 mA maximum, regulated, 5 Vdc ±5% (Received through RS 232 cable)
Speaker	Audible key click, bell and alert
Storage Temperature	-4° F (-20° C) to 158° F (+70° C)
Operating Temperature	32° F (0° C) to 122° F (+50° C)
Relative Humidity	10% to 90% non-condensing

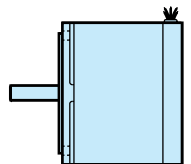

SIT (HAND-HELD INTERFACE)

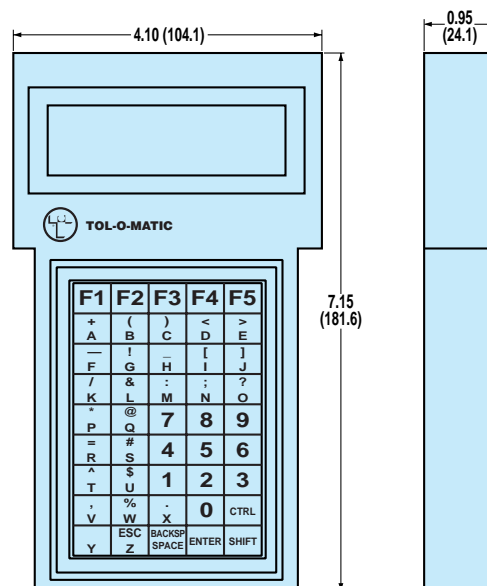

MICROSTEPPING

SIT Hand-held User Interface

- Features
- Specifications
- Dimensions

Axi-dyne[®] Microstepping System

CABLES

MRS MOTORS TO MSD DRIVE

MRS171, MRS231, MRS232,
MRS341, MRS342, MRS343



TO:

MSD
or
MSS

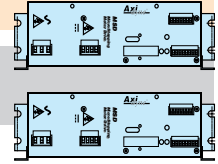

Config Code	Replacement Part Number	Included with Drive	Type	Description	Cable Length	Motor Size	CONNECTORS AT Motor	CONNECTORS AT MSD-MSS	MSD MSS
-	-	Cust. supplied	Power		0.3m	All	Flying leads	Screw terminal	All

MSD DRIVE TO SSC CONTROLLER

MSD

TO:

SSC

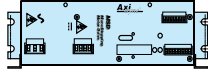

BREAKOUT BOX

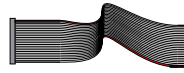

RIBBON CABLE

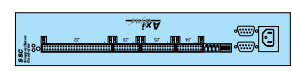

Config Code	Replacement Part Number	Included with SSC	Type	Description	Cable Length	Drive Sizes	CONNECTORS AT Drive	CONNECTORS AT SSC	SSC Size
-	3600-1347	YES	Main/Driver Signals	Ribbon Breakout	1m	All	Screw terminals	IDC	All
-	3600-1342	YES							
-	3600-1346	YES	I/O	Ribbon Breakout	1m	All	Screw terminals	IDC	All
-	3600-1341	YES							
-	3604-1345	YES	Step/Dir Signals	Ribbon Breakout	1m	All	Screw terminals	IDC	All
-	3600-1340	YES							

SSC CONTROLLER TO IBM COMPATIBLE PC

SSC

TO:

PC



CRZ

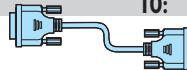

Config Code	Replacement Part Number	Included with SSC	Type	Description	Cable Length	SSC Size	CONNECTORS AT SSC	CONNECTORS AT PC	PC Size
CRZ	3600-1172	Optional	Comm		1m	All	DB9	DB9	All

MSS DRIVE/CONTROLLER TO IBM COMPATIBLE PC

MSS

TO:

PC



Config Code	Replacement Part Number	Included with MSS	Type	Description	Cable Length	MSS Size	CONNECTORS AT MSS	CONNECTORS AT PC	PC Size
-	-	YES	Comm		2m	All	RJ11	DB9	All

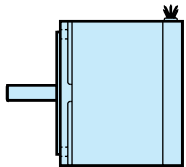

MICROSTEPPING

Cables

Axi-dyne[®] Microstepping System

ORDERING

MOTOR STYLE, SIZE AND GEARHEAD REDUCTION

MRS 231 GHK20

MOTOR TYPE
MRS Stepping Motor

MOTOR SIZE / DRIVE SIZE

MODEL	FRAME SIZE	STACK SIZE	DRIVE
171	17	1	MSD
231	23	1	MSD
232	23	2	MSD
341	34	1	MSD
342	34	2	MSD
343	34	3	MSD

Once motor type and frame size is selected, the appropriate adapter and couplers required are automatically chosen.

NO DRIVE OPTION
X Add X if motor drive is NOT required

NO MOTOR OPTION
XY* Motor(s) supplied by customer, Tol-O-Matic to mount using standard hardware and couplers
XJ* Motor(s) supplied and mounted by customer, Tol-O-Matic to furnish standard hardware and couplers

* For XY and XJ options, a full endface and shaft dimensional drawing must accompany the order for the actuator. Customer motors must be directly interchangeable with Tol-O-Matic motors.

GEARHEAD REDUCTIONS

(For In-line or Direct-Drive mounting configurations only)

MODEL	INPUT DIA.	MOTOR SIZE	REDUCTION RATIO
GHK20	1/4-inch	23	5.5
GHK30	3/8-inch	34	5.5

CONTROLLER

SSC21

CONTROLLER/DRIVE OR CONTROLLER

SINGLE AXIS APPLICATIONS
MS MSS Controller/Drive
SSC10 Stepper/Servo Controller, 1 axis application

MULTI AXIS APPLICATIONS

****2 Axis Application**
1st Axis 2nd Axis
SSC21 Stepper Stepper
SSC22 Stepper Servo

****3 Axis Application**
1st Axis 2nd Axis 3rd Axis
SSC31 Stepper Stepper Stepper
SSC32 Stepper Stepper Servo
SSC33 Stepper Servo Stepper
SSC34 Stepper Servo Servo

****4 Axis Application**
1st Axis 2nd Axis 3rd Axis 4th Axis
SSC41 Stepper Stepper Stepper Stepper
SSC42 Stepper Stepper Stepper Servo
SSC43 Stepper Stepper Servo Stepper
SSC44 Stepper Stepper Servo Servo
SSC45 Stepper Servo Stepper Stepper
SSC46 Stepper Servo Stepper Servo
SSC47 Stepper Servo Servo Stepper
SSC48 Stepper Servo Servo Servo

CABLES, CONNECTIONS & INTERFACE

CRZ BON

CABLES

For MRS motors: include 12" (0.3m) leads

For SSC Controllers
CRZ If a 2-meter 9-pin RS232 cable is desired

⚠ Indicate if breakout terminal and ribbon cables are needed.

BON No breakout terminals
BOY*** With breakout terminals

***BOY option includes:
• 60 pin/18" (457mm) ribbon cable & 60 pin breakout
• 26 pin/18" (457mm) ribbon cable & 26 pin breakout
• If any axis configured w/ step & direction output —
20 pin/18" (457mm) ribbon cable & 20 pin breakout

JS

USER INTERFACE

PIT Panel mount user interface (for use with MSS)
SIT Hand-held user interface
JS Joy Stick

⚠ Not all codes listed are compatible with all options.

Use the Tol-O-Motion™ Sizing Software to determine available options and accessories based on your application requirements.

User manuals and software CD-ROM is included with any controller or drive ordered. Manuals and software are also available for download at www.tolomatic.com

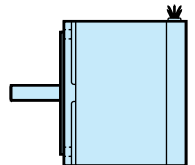

MICROSTEPPING

System Ordering

TO ORDER ACTUATORS

- B3S/M3S SERIES (SEE PAGE C-30)
- B3B/M3B SERIES (SEE PAGE C-50)
- TKS SERIES (SEE PAGE C-82)
- TKB SERIES (SEE PAGE C-104)
- BCS/MCS SERIES (SEE PAGE C-128)
- SLS/MLS SERIES (SEE PAGE C-138)
- RSA/RSM SERIES (SEE PAGE D-53)
- GSA/GSM SERIES (SEE PAGE E-36)

Axi dyne[®] Microstepping System

FIELD RETROFIT ORDERING

*SSC 1-4 CONTROLLERS

Code	X-Axis	Y-Axis	Z-Axis	W-Axis	Part #
SSC10	Stepper	-	-	-	3600-0110
SSC21	Stepper	Stepper	-	-	3600-0121
SSC22	Stepper	Servo	-	-	3600-0122
SSC31	Stepper	Stepper	Stepper	-	3600-0131
SSC32	Stepper	Stepper	Servo	-	3600-0132
SSC33	Stepper	Servo	Stepper	-	3600-0133
SSC34	Stepper	Servo	Servo	-	3600-0134
SSC41	Stepper	Stepper	Stepper	Stepper	3600-0141
SSC42	Stepper	Stepper	Stepper	Servo	3600-0142
SSC43	Stepper	Stepper	Servo	Stepper	3600-0143
SSC44	Stepper	Stepper	Servo	Servo	3600-0144
SSC45	Stepper	Servo	Stepper	Stepper	3600-0145
SSC46	Stepper	Servo	Stepper	Servo	3600-0146
SSC47	Stepper	Servo	Servo	Stepper	3600-0147
SSC48	Stepper	Servo	Servo	Servo	3600-0148

NOTE: Any axis of the SSC may be changed by the insertion or removal of a jumper, see SSC manual #3600-4608

*Includes user manual and software CD-ROM

CABLES

Item	Part #
20 pin breakout	3600-1340
26 pin breakout	3600-1341
60 pin breakout	3600-1342
20 pin ribbon cable	3600-1345
26 pin ribbon cable	3600-1346
60 pin ribbon cable	3600-1347
RS232 Cable	3600-1172
SSC Encoder cable	3604-1213
RS232 - 9 Pin Adapter for MSS/MSD	3600-1186
RS232 Cable Only for MSS/MSD	3600-1187

*MSS CONTROLLER / DRIVE

Config. Code	Includes	Part #
MSS	Controller/Drive (order cables below)	3600-0038

*Includes user manual and software CD-ROM

*MSD DRIVE

Config. Code	Includes	Part #
MSD	Drive only (order cables below)	3600-0039

*Includes user manual and software CD-ROM

MRS STEPPING MOTORS

Config. Code	Part #
MRS171**	3600-6129
MRS231	3600-6130
MRS232	3600-6131
MRS341	3600-6132
MRS342	3600-6133
MRS343	3600-6134

** For RSA Rod Screw Actuators only

USER INTERFACES

Config. Code	Part #
PIT	3600-9607
SIT	3600-9161
JS	3600-9162

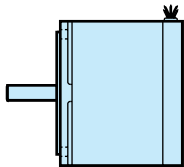

MICROSTEPPING

Field Retrofit Ordering

FIELD RETROFIT ORDERING



BRUSHLESS (SEE PAGE F-34)

BRUSHED DC (SEE PAGE H-27)



- **MRB BRUSHED SERVO MOTORS**
- **AXIOM® DB BRUSHED SERVO DRIVE**
- **MSC CONTROLLER**
- **SSC CONTROLLER**
- **PIT PANEL MOUNT INTERFACE**
- **JS JOYSTICK INTERFACE**
- **SIT HAND-HELD INTERFACE**



BRUSHED DC

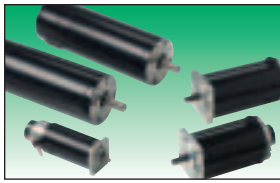

Axi-dyne® Brushed dc System

OVERVIEW

APPLICATION BENEFITS

- Low to medium cost
- Smooth and quiet operation
- Good for speeds generally less than 2500 rpm
- Good for torques up to 32 in-lbs. (3.62 N-m) continuous, 48 in-lbs. (5.42 N-m) peak
- Good for resolutions of 1,000 counts per revolution

MOTOR



MRB - Brushed DC Motors

- 1,000 line optical encoder available for servo operation
- NEMA 17, 23 and 34 mounting

DRIVE



AXIOM® DB - Brushed DC Servo Drive

- Peak current ratings of 20A
- Simple Windows®-based software
- Excellent performance and accuracy at high speeds
- Optically isolated inputs: dedicated CW/CCW travel limit; drive enable, step/direction and step CW/step CCW
- Optically isolated outputs

CONTROLLER



MSC Controller:

- Software icons for intuitive setup & programming
- Built-in power supplies: 24 Vdc, 100mA is provided for the user for sensors and I/O circuits.
- Optically isolated inputs: 4 dedicated, CW and CCW jog, 2 limits; 4 general purpose
- Optically isolated outputs: drive fault output; 3 general purpose; differential step and direction outputs
- Programmable resolution to match encoder

CONTROLLER



SSC Controller:

- Performs any motion task including jogging, point-to-point positioning, linear and circular interpolation, electronic gearing, camming and contouring
- Multitasking feature permits simultaneous execution of four independent applications programs
- Tol-O-Motion SSC Motion Control Software allows setup & programming with easy-to-use Windows® interface
- Up to 4 axes per unit - up to 4 units can be daisy-chained
- 4M non-volatile EEPROM memory for executing custom application programs - permits stand-alone operation
- Relative and absolute positioning with more than $\pm 2,000,000,000$ counts per move
- Inputs: opto-isolated dedicated for home, abort, forward and reverse limits, 8 uncommitted; 7 analog inputs
- Outputs: 8 programmable

INTERFACES



PIT - Panel mount interface

- Keypad, LCD display for use with MSC Controller

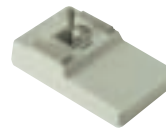

JS - Joystick

- Use with SSC joystick teach mode



SIT - Hand-held interface

- 45 key - keypad, LCD display
- for use with SSC

Host compatible PC

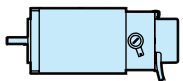

BRUSHED DC

Overview

Axi-dyne® MRB Brushed dc Motors

FEATURES & PERFORMANCE



MRB Brushed DC Motors

For cost sensitive applications requiring smooth and quiet operation, Tol-O-Matic provides the MRB series brushed DC motors. Available with a wide range of torque/speed characteristics, the MRB motors are ideal for operation in a servo system (AXIOM™ DB).

MRB FEATURES

- Rugged industrial enclosures
- 1000 line encoder for servo operation
- Ideal for operation with AXIOM™ DB brushed servo drives

CABLES

All MRB series motors include a 24-inch flying lead motor power cable.

Encoder cables are 18 inch flying leads.

WIRE COLORS

1	2	3	4	5	6	7	8	
+VCC	GND	A+	A-	B+	B-	I+	I-	Shield
Red	Black	White	Yellow	Green	Blue	Orange	Brown	Drain

MRB MOTOR SPECIFICATIONS

	KE (1)		KT (2)		RESISTANCE (3)		ROTOR INERTIA		THERMAL RESISTANCE	CONT. STALL TORQUE		PEAK STALL TORQUE		MAXIMUM SPEED	INDUCTANCE (4)		WEIGHT	
	Volts/1000RPM	oz-in/Amp	N-m/Amp	Ohms	oz-in ²	gr-cm ²	°C/W	oz-in	N-m	oz-in	N-m	RPM	mH	lbs	kgs			
MRB21	12.7	17.2	0.121	2.20	2.89	529	4	57	0.402	400	2.82	4000	6.40	3.5	1.6			
MRB31	8.6	11.6	0.082	0.60	6.55	1200	2.7	100	0.706	480	3.39	4000	0.42	5.11	2.3			
MRB32	13.4	18.1	0.128	0.46	13.1	2400	1.9	210	1.48	960	6.78	4000	0.64	8.6	3.9			
MRB41	20	27.2	0.192	0.6	101	18500	1.09	376	2.65	2496	17.6	4000	2.2	17	7.7			
MRB42	38	51.4	0.363	8.6	122	23000	0.90	496	3.50	3296	23.3	3500	4.4	20.0	9.1			

(1) ±10 (2) ±10% (3) ±10% at 25° (4) ±15%

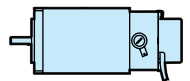

BRUSHED DC

MRB Motors

- Features
- Performance

Axi-dyne[®] MRB Brushed dc Motors

PERFORMANCE DATA WITH AXIOM[®] DB DRIVES

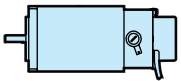
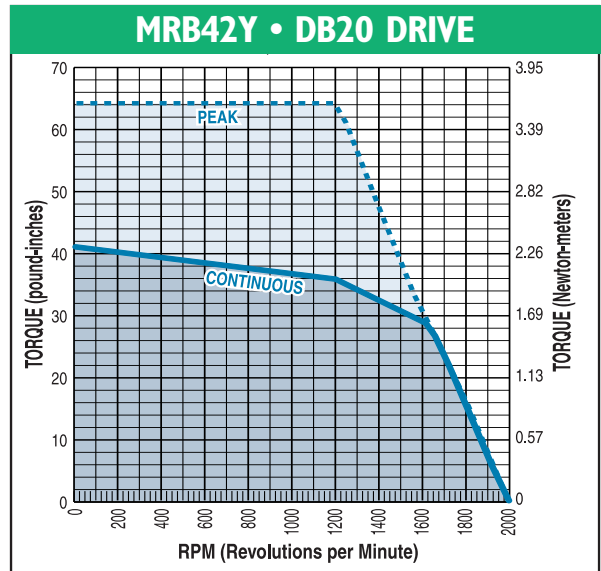
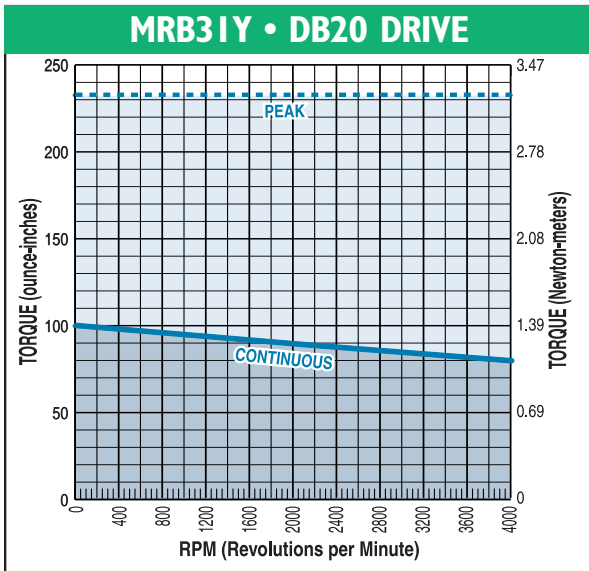
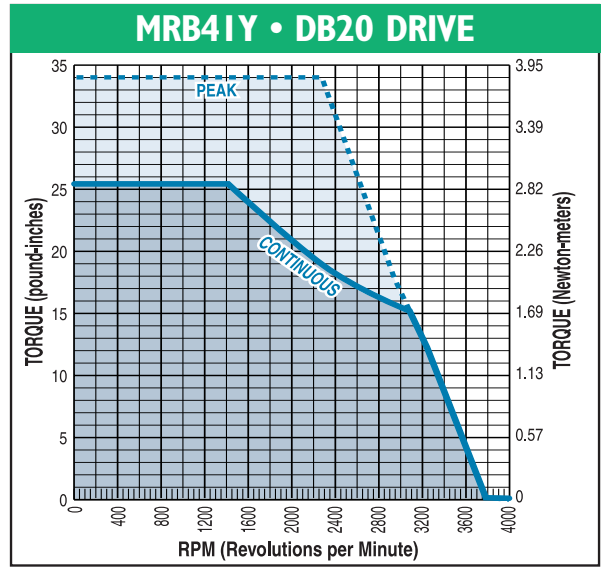
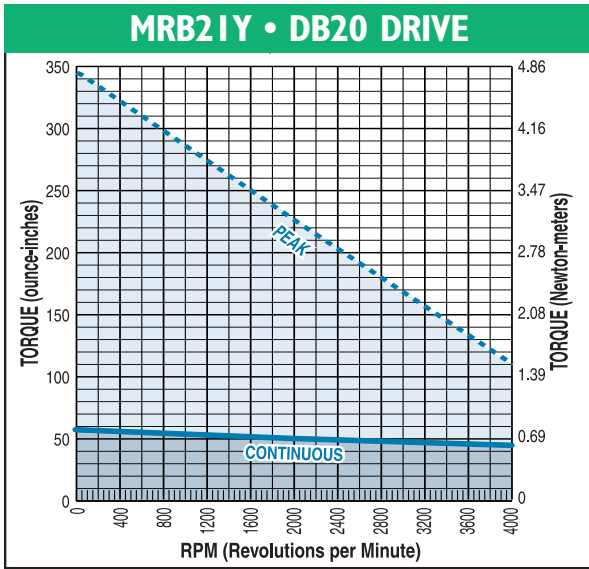

BRUSHED DC

MRB Motors

- Performance with Axiom DB drives

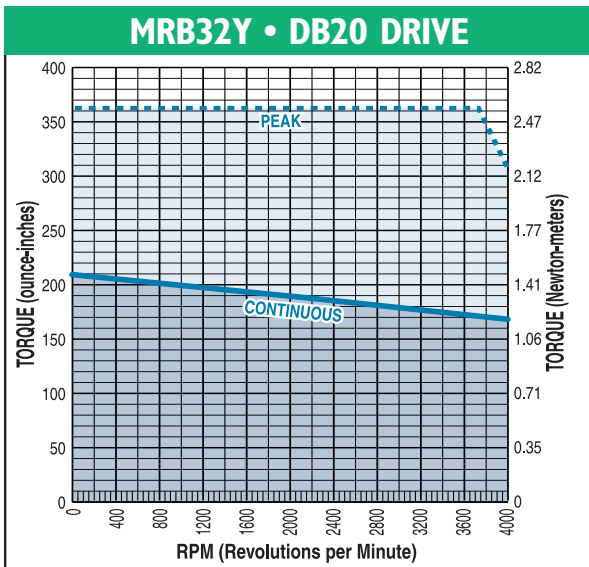

Axi-dyne® MRB Brushed dc MOTORS

DIMENSIONS

MRB21

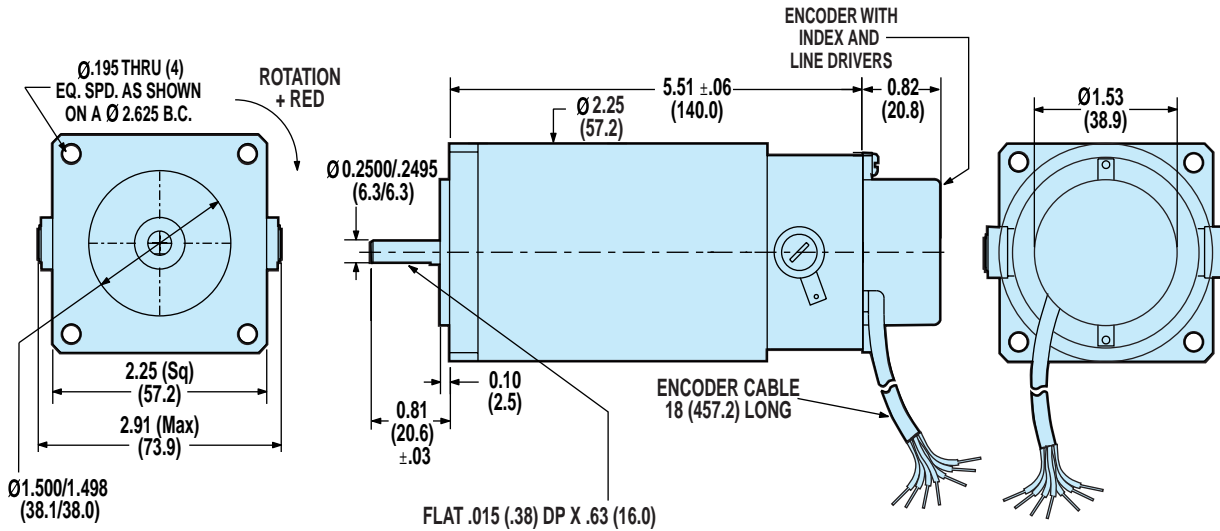

MRB31 / MRB32

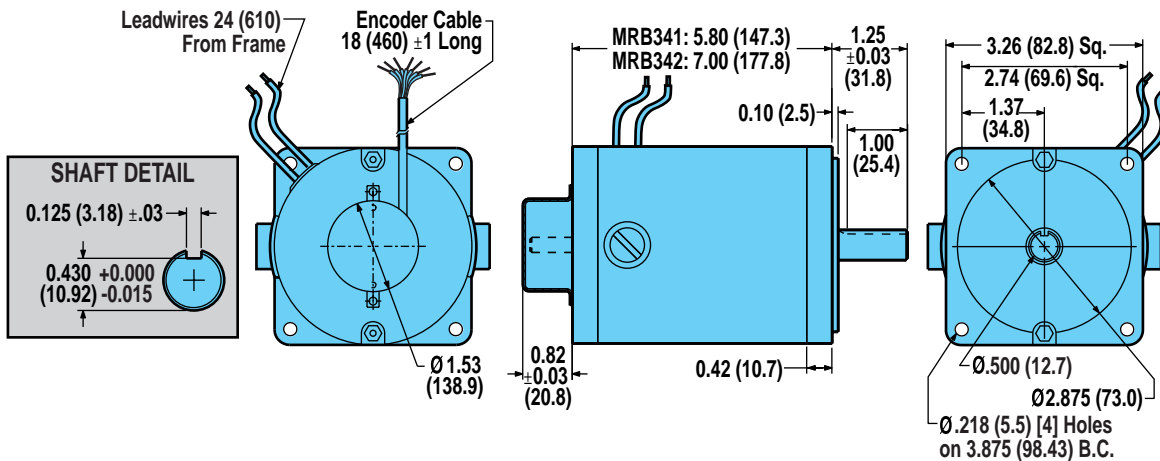

MRB41 / MRB42

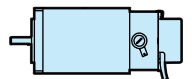
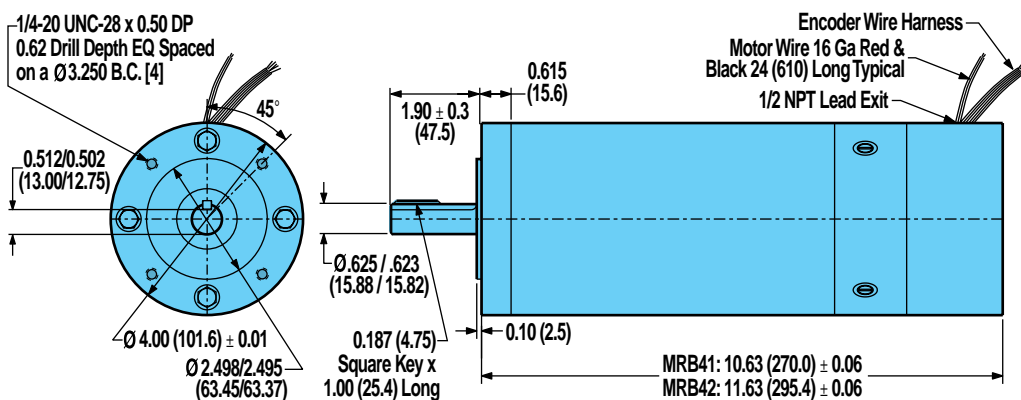

BRUSHED DC

MRB Motors

• Dimensions

Unless otherwise noted, all dimensions shown are in inches (Dimensions in parenthesis are in millimeters)

Axi dyne® Gearhead Reduction

SPECIFICATIONS AND DIMENSIONS

COMPATIBILITY:
SYSTEM: BRUSHLESS
MOTORS: MRV
ACTUATORS: ALL
TOL-O-MATIC
SCREW
DRIVES

COMPATIBILITY:
SYSTEM: STEPPER
MOTORS: MRS
ACTUATORS: ALL
TOL-O-MATIC
SCREW
DRIVES

COMPATIBILITY:
SYSTEM: BRUSHED DC
MOTORS: MRB
ACTUATORS: ALL
TOL-O-MATIC
SCREW
DRIVES



For a complete part listing of screw-drive motor and gearhead mounting kits referencing actuator/motor/coupler compatibilities, refer to document 3600-4631 available on the Literature/Axidyne/Part Sheet section of our web site at: www.tolomatic.com.

For those applications requiring reduction for inertia matching or higher torque at lower speeds, Tol-O-Matic offers high efficiency, single stage, true planetary gearheads. Gear ratios of 5.5:1 and 10:1 are available and are compatible with 23- and 34-frame MRV Brushless Servo, MRS Microstepping and Brushed DC motors.

SPECIFICATIONS

Efficiency:	85%
Backlash:	less than 10 arc minutes
Max. Input Speed:	5000 RPM

CONFIG NO.	PART NO.	FRAME SIZE	GEAR RATIO	REFLECTED INERTIA*		INPUT SHAFT DIA. (in)	WEIGHT	
				lb-in ²	kg-m ²		lbs	kgs
GHK20	3600-6150	23	5.5 : 1	0.0213	6.22	0.250	1.78	0.81
GHJ20	3600-6151	23	5.5 : 1	0.0213	6.22	0.500	2.00	0.91
GHJ21	3600-6152	23	10 : 1	0.0181	5.30	0.500	1.98	0.90
GHK30	3600-6153	34	5.5 : 1	0.1131	33.09	0.375	4.68	2.12
GHJ30	3600-6154	34	5.5 : 1	0.1131	33.09	0.500	4.60	2.09
GHJ31	3600-6155	34	10 : 1	0.0888	25.96	0.500	4.78	2.17
GHJ32 [§]	3600-6156	34	10 : 1	0.0888	25.96	0.500	4.81	2.18

▲ * Reflected inertia is inertia at motor side of gearhead.
§ Only available on RSA64 LMI

23- AND 34-FRAME GEARHEADS

23 FRAME GEARHEAD

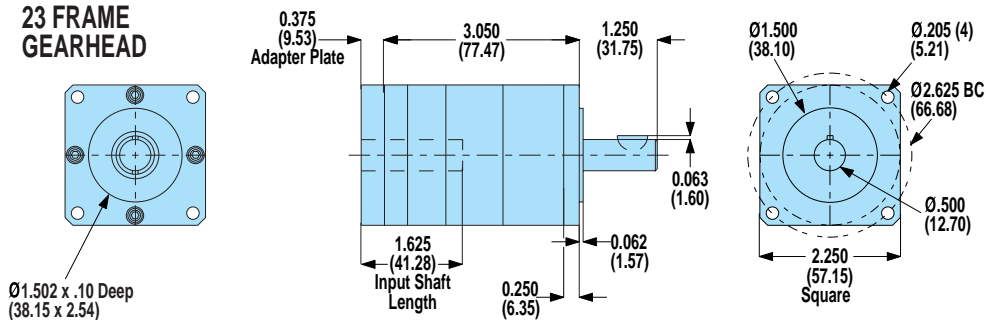

34 FRAME GEARHEAD

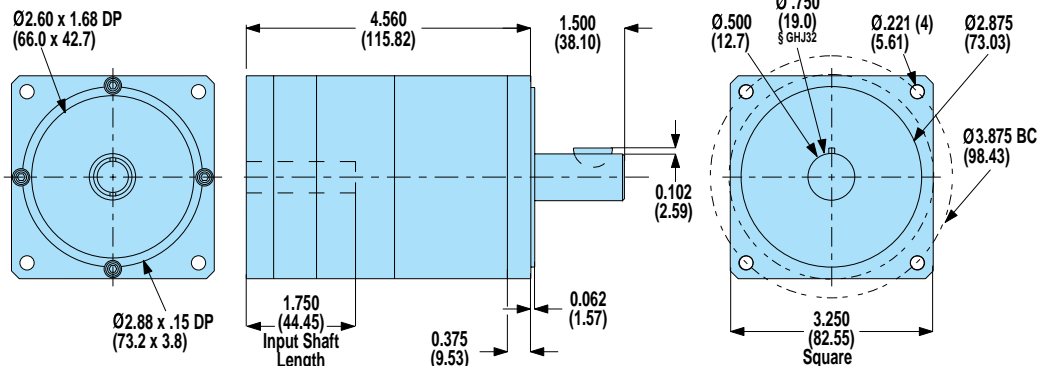

Unless otherwise noted, all dimensions shown are in inches (Dimensions in parenthesis are in millimeters)

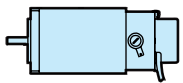

BRUSHED DC

Gearhead Reduction

- Specifications
- Dimensions

Axi dyne[®] Axiom[®] DB Brushed dc Drive

FEATURES

COMPATIBILITY:

SYSTEM: BRUSHED DC

MOTORS: MRB

DRIVE: AXIOM DB

CONTROLLER: SSC

INTERFACE: JS
SIT



The Axiom[®] series brushed servo drive combines high-speed accuracy with user friendly set-up and diagnostics. The Axiom[®] DB series is a state-of-the-art DSP controlled digital drive capable of driving a full range of brushed servo motors. Available in a 20 Amp peak rating (3 sec) and equipped with convenient pluggable screw terminal connectors, the Axiom DB series offers fast, easy set-up and installation for use in a wide variety of applications.

AXIOM DB DRIVE FEATURES

- Space vector commutation provides better bus voltage utilization than traditional sine drives for improved speed/torque curves
- Digital current control provides more accurate high bandwidth control of torque producing current
- Drives MRB series brushed dc motors
- Pluggable screw terminal connectors eliminate the need for special connectors and secondary breakout terminal strips
- 115Vac input, single phase
- Short circuit, over current and over voltage protection prevents drive damage
- 50W internal regeneration
- External regeneration connections
- Analog torque and velocity command (\pm) 10V
- Feedback from differential A+B and index channel optical encoder (5V)
- Maximum line count of 500,000/motor commutation cycle
- CW/CCW travel limit inputs
- Drive enable input
- Fault, enabled, and in-position outputs
- 3A brake relay
- 3 second peak ratings

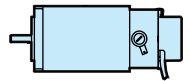

BRUSHED DC

Axiom DB Drive

- Features

Axi dyne[®] Axiom[®] DB Brushed dc Drive

SPECIFICATIONS

AXIOM DB DRIVE SPECIFICATIONS

Power	
Continuous Current Rating:	15 Amps
Peak Current Rating (3 sec):	20 Amps
Max Input Current (single phase):	10 Amps (rms)
Input Voltage (single/3-phase):	95Vac -130Vac Single Phase
Input Frequency:	47Hz - 63Hz
Command Sources	
Analog Torque/Velocity Input:	± 10V, 16.4K ohm impedance
Step and Direction or Step CW/Step CCW	1 MHz maximum, 5V differential or single ended drivers
Serial Communication Port	
Type:	RS232
Baud Rate:	19,200 baud
Control Loops	
Type:	All digital
Loop Modes:	Torque, Velocity and Position Control
Torque Update Rate:	10KHz
Velocity Update Rate:	5KHz
Position Update Rate:	2.5KHz
Inputs and Outputs	
Dedicated Optically Isolated Inputs:	5Vdc - 25Vdc, 2.7ma - 15ma ENABLE, CW LIMIT and CCW LIMIT. Can be configured to source or sink current.
Dedicated Optically Isolated Outputs:	3 optically isolated, 25Vdc max., 50ma max. IN POSITION, ENABLED and FAULT. Can be configured to source or sink current.
1 Dedicated Brake Relay Output:	N.O. contact, 24Vdc, 115/230Vac, 3A max.
Motor Feedback:	Incremental encoder, 5Vdc, differential 4Mhz max., A/B/I channels 250 line min. with a 4 pole motor 125 line min. with a 2 pole motor
Encoder Output:	Differential, 5Vdc, A/B/I channels
Connectors	
Serial:	9 pin D-Sub.
Control and Feedback:	15 pin D-Sub.
Power, Motor, Brake Relay, Regen:	Screw terminal block
All Others:	Pluggable screw terminal blocks
Approvals:	
UL, CUL, CE	
Environmental	
Storage Temperature:	-40°C to 70°C
Operating Temperature:	0°C to 50°C
Humidity:	5% to 95%, non-condensing
Weight:	26 lbs. (12 kgs.)

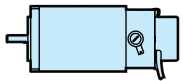

BRUSHED DC

Axiom DB Drive

- Specifications

Axi dyne[®] Axiom[®] DB Brushed dc Drive

CONNECTORS

AXIOM DB DRIVE CONNECTORS

TB1 - BRAKE

1 - Brake

2 - Brake

TB2 - MOTOR

1 - Motor +

2 - Motor -

3 - Motor Ground

TB3 - AC POWER

1 - 120Vac

2 - Neutral

3 - Ground

J3 - OUTPUTS

1 - In Position + 4 - Enabled Out -

2 - In Position - 5 - Fault Out +

3 - Enabled Out + 6 - Fault Out -

J4 - INPUTS

1 - CW Limit 6 - Step/Step CW +

2 - CCW Limit 7 - Step/Step CW -

3 - Limit Common 8 - Direction/Step CCW +

4 - Enable + 9 - Direction/Step CCW -

5 - Enable -

ANALOG INPUT COMMAND

1 - Analog Common 3 - Analog -

2 - Analog + 4 - Shield

J7 - MOTOR ENCODER

1 - Encoder +5V 6 - I+

2 - A+ 7 - I-

3 - A- 8 - Common/Shield

4 - B+ 9 - Motor Temp

5 - B-

PI - BUFFERED ENCODER OUTPUT

1 - Reserved 8 - Common

2 - Reserved 9 - Encoder Out A+

3 - Reserved 10 - Encoder Out A-

4 - Reserved 11 - Encoder Out B+

5 - Reserved 12 - Encoder Out B-

6 - Reserved 13 - Encoder Out I+

7 - Reserved 14 - Encoder Out I-

P2 - COMMUNICATIONS

1 - Reserved 6 - Reserved

2 - RS-232 TX 7 - Reserved

3 - RS-232 RX 8 - Reserved

4 - Reserved 9 - +5Vdc (30ma MAX.)

5 - Common

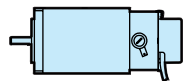

BRUSHED DC

Axiom DB Drive

- Connectors

Axi-dyne® Axiom® DB Brushed dc Drive

SET-UP / CONFIGURATION

Axiom® Windows®-based PC setup software with a “control-panel” approach, makes it easy to get up and running fast. All set-up and configuration functions are performed using two main control-panel screens. Simple mouse-click commands automatically configure the control functions, eliminating layers of screens and menus. This approach also allows more relevant diagnostic information to be displayed simultaneously. All control screens include a command menu at the upper left to permit convenient selection of high-level functions and options.

A main menu is provided which allows selection of the main control panel functions, active comm port, etc. Tutorial selections are provided which emulate the main control-panel functions in an off-line manner and provide “help” text and function definitions/ descriptions so that users can actively familiarize themselves with the software without actually connecting a drive.

The software communicates with the drive using a standard RS-232 connection operating at 19,200 baud, using either comm port 1 or 2 of the PC. It can be installed and executed from any PC running Windows 95, 98, NT, 2000 or XT.

SET-UP CONFIGURATION

Drive operating mode and other options can all be selected/enabled from this screen. All set-up parameters can be uploaded and downloaded with a single click of the mouse. The parameter set can be saved to or retrieved from a disk file. Once downloaded to the drive, all parameters are stored in non-volatile EEPROM memory.

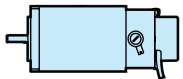

BRUSHED DC

Axiom DB Drive

- Setup and configuration

The screenshot shows the 'Setup and Configuration' window with several sections:

- Commands, Set-up and Configuration Mode:** Includes buttons for 'Select Drive', 'Select Standard Motor', 'Retrieve Parm's from Disk File', 'Upload Parm's from Drive', 'Download Parm's to Drive', 'Save Parm's to Disk File', and 'Exit Drive Set-Up Mode'.
- Drive Model Selection / Setup:** Shows 'Drive Model #: DV10', 'Drive Continuous Current: 5', 'Drive Peak Current: 10.0 amps', and various travel and output limits.
- Motor Model Selection / Setup:** Shows 'Motor Model #: MRV21', 'Motor Cont. Stall Torque: 3.75 in-lbs', 'Motor Peak Torque: 11.3 in-lbs', 'Ke, Volts L-L rms/krpm: 8.8', 'Kt, in-lbs/Amp ph rms: 1.29', '# of Magnetic Poles: 4', 'Encoder pulses/rev (x4): 4000', and 'Maximum Speed, rpm: 6000'.
- Drive Operating Mode Selection:** Includes radio buttons for 'Torque Mode, Analog Input', 'Velocity Mode, Analog Input' (selected), 'Step/Dir Input Position Mode', and 'CW/CCW Input Position Mode'.
- Gains and Offsets:** Shows 'Anl Offset = 0 mV', 'Vl gain = 0', 'Anl In SF = 1.00', 'Vl gain = 0', 'VP gain = 18', 'All gain = 3', and 'Vl gain = 55'.
- Phasing Configuration:** Shows 'Phasing Position Increment (degrees): 0' and 'Phasing Torque (% of drive peak): 60%'.

Red arrows point to the following sections with labels:

- DRIVE MODEL # DISPLAY AND PARAMETER CONFIGURATION.** (Points to Drive Model Selection / Setup)
- DRIVE MODE SELECTION.** (Points to Drive Operating Mode Selection)
- DISPLAY OF TUNING AND OFFSET PARAMETERS FOR REFERENCE PURPOSES (SET IN TUNING CONTROL SCREEN).** (Points to Gains and Offsets)
- MOTOR SELECTION AND CONFIGURATION.** (Points to Motor Model Selection / Setup)
- CONFIGURATION/SET-UP FOR AUTO-PHASING FUNCTION INCLUDING INDEX PULSE MONITORING FOR COMMUTATION ACCURACY AND FASTER DETECTION OF FEEDBACK ERRORS.** (Points to Phasing Configuration)

Axi dyne® Axiom® DB Brushed dc Drive

SET-UP / CONFIGURATION

TUNING AND DIAGNOSTICS

Use the 4-channel oscilloscope display for analysis of motion response when tuning and diagnosing. Scaling and format of the displayed traces can be easily modified. Values can be read directly off the traces at any point. Continuously updated bar graph displays allow important data to be viewed while motion is occurring. These displays are configured automatically based on drive operating mode they include peak detection functions and numeric displays. A status section of this control screen displays the current state of I/O and fault information.

Selecting "Drive-Tuning" from the command menu activates and displays the control functions for manual and automatic drive tuning. Use these controls to set-up and start actuation of an appropriate unit-step motion command and then enable automatic tuning parameter adjustment. Manual adjustments to tuning parameters can be easily accomplished.

The oscilloscope functions are used in conjunction with tuning, ensuring desired response goals are achieved. All tuning parameters are updated and activated immediately in the drive when modified (and also stored in EEPROM memory).

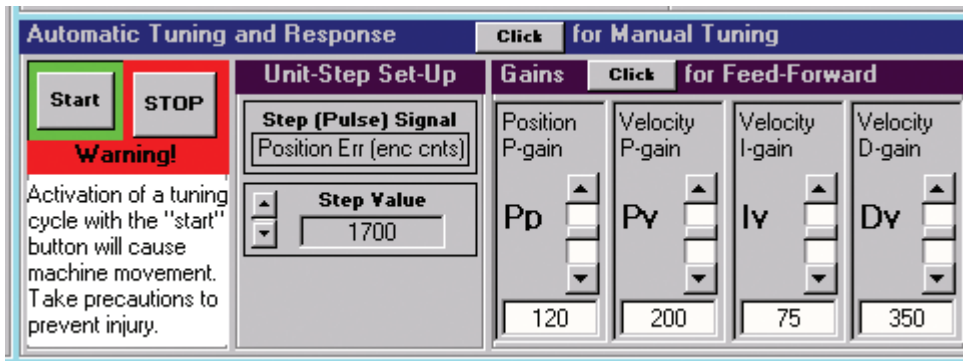

TUNING CONTROLS ALLOW USER CONFIGURABLE UNIT-STEP ACTUATION. AUTOMATIC AND MANUAL TUNING FUNCTIONS ARE PROVIDED. OPTIONAL VALUES FOR FEED FORWARD GAINS AND ANALOG OFFSETS CAN ALSO BE ENTERED.

4-CHANNEL OSCILLOSCOPE DISPLAY FOR SET-UP/TUNING AND SUBSEQUENT DIAGNOSIS. FLEXIBLE DISPLAY CONFIGURATION AND SLIDING VALUE INDICATOR, MAKE ANALYSIS QUICK AND EASY. INCLUDES USER CONTROLLED TRIGGER FUNCTIONS.

ALL SOFTWARE SCREENS INCLUDE SEPARATE MENUS OF HIGH-LEVEL FUNCTIONS IN THE UPPER LEFT CORNER TO FACILITATE QUICK TRANSITIONS BETWEEN SCREENS AND FUNCTIONS.

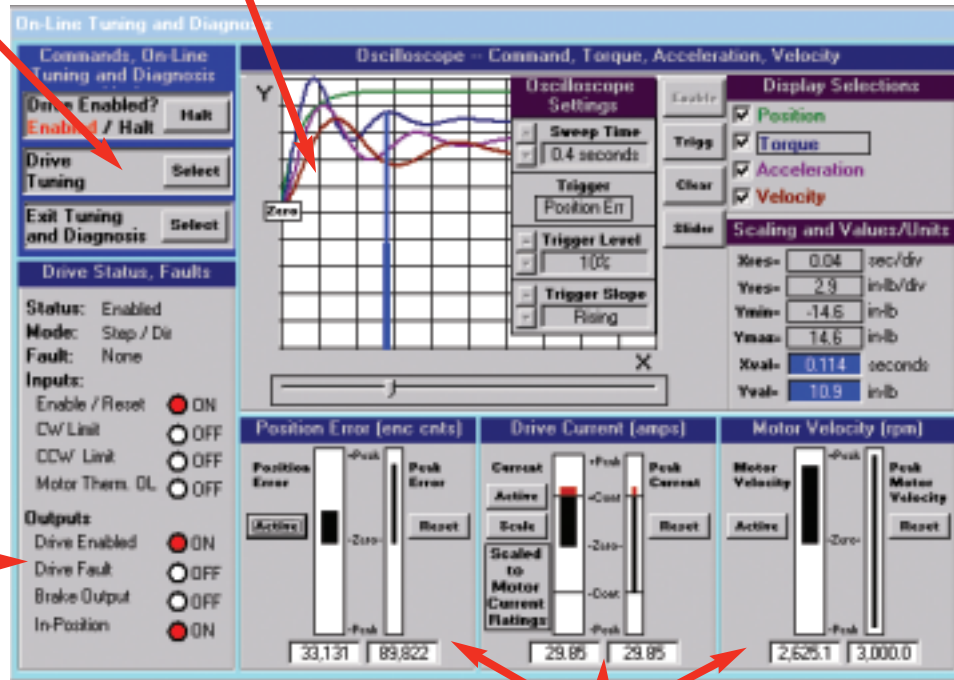

CONTINUOUS DISPLAY OF CRITICAL DRIVE STATUS INFORMATION AS WELL AS PHYSICAL STATE OF I/O.

DIAGNOSTIC BAR GRAPH DISPLAYS OF CRITICAL SYSTEM VALUES, UPDATED CONTINUOUSLY. INCLUDES PEAK DETECTION AND NUMERIC DISPLAY.

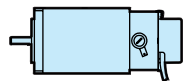

BRUSHED DC

Axiom DB
• Set-up / configuration

Axi-dyne® Axiom® DB Brushed dc Drive

DIMENSIONS

AXIOM DB20 DRIVE

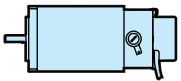
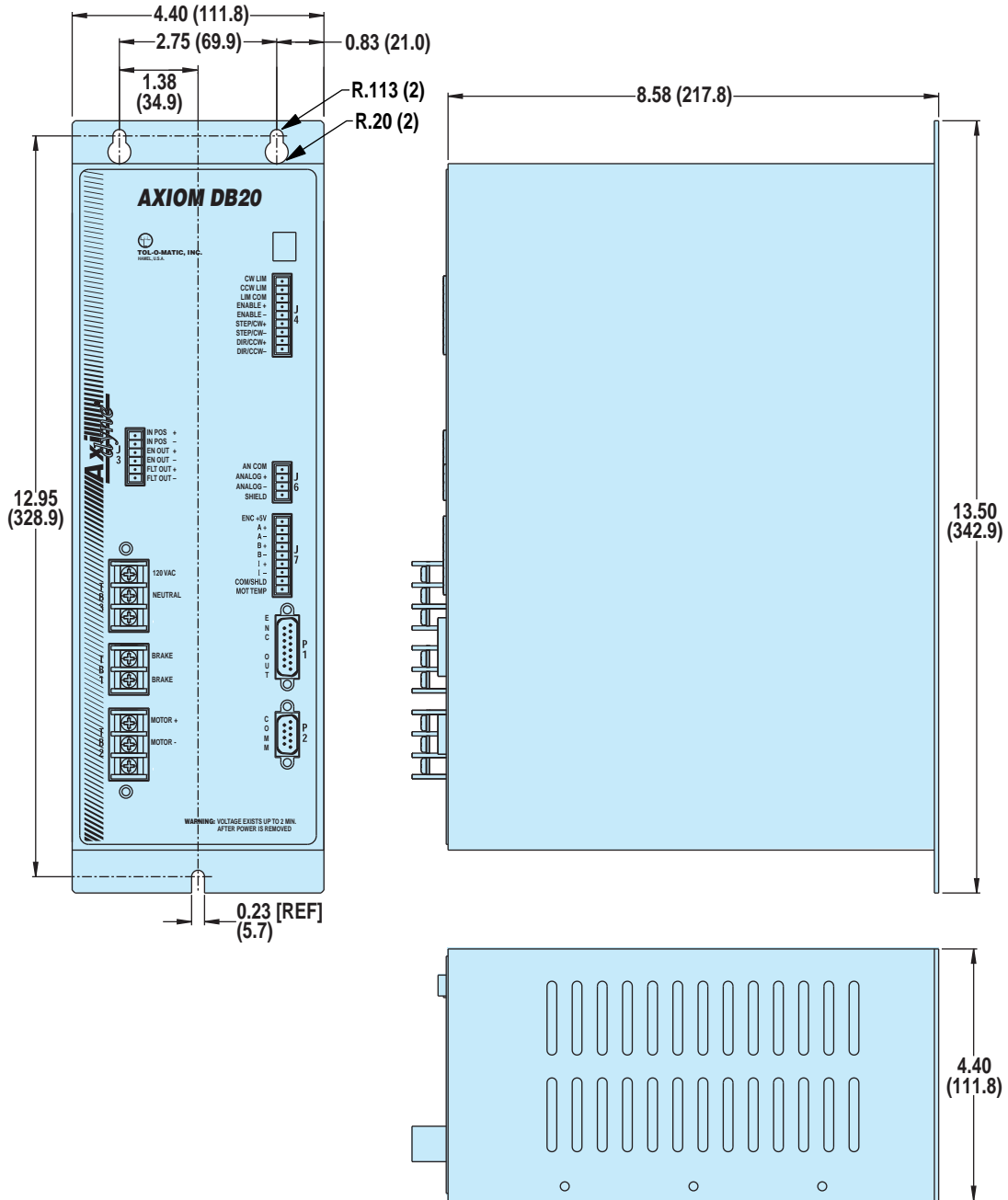

BRUSHED DC

Axiom DB Drive
• Dimensions

Unless otherwise noted, all dimensions shown are in inches (Dimensions in parenthesis are in millimeters)

Axi-dyne[®] MSC Controller

FEATURES AND SPECIFICATIONS

COMPATIBILITY:
 SYSTEM: BRUSHED DC
 MOTORS: MRB
 DRIVE: AXIOM DB
CONTROLLER: MSC
INTERFACE: PIT



The MSC Microstepping Controller provides the simplest, quickest way to get up and running in a single-axis application. The Tol-O-Motion MS software allows sophisticated programming to be achieved by even the most novice user, through icons arranged in a simple, easy to follow format. Once programmed over the RS232 the PC may be removed and program interaction achieved through I/O, or by using the PIT panel mount interface. The MSC Microstepping controller comes as a stand-alone controller making it ideal for operation with the AXIOM™ DB brushed dc motor driver, or integral to the MSD microstepping drive.

MSC FEATURES

- Built-in power supplies: 24 Vdc, 100mA is provided for sensors and I/O circuits.
- Accepts 115 or 230 volt AC power
- 4 dedicated, optically isolated inputs: CW and CCW jog, 2 limits
- 4 general purpose, optically isolated inputs
- Drive fault output
- 3 general purpose, optically isolated outputs
- Pluggable screw terminal connectors for I/O, motor, AC power (all mating connectors included)
- Selectable linear scale simplifies linear motion programming
- Absolute positioning
- Single step program execution

MSC SPECIFICATIONS

Power	
Input Voltages (AC line):	115 or 230 Vac, 50-60Hz (switch selected)
Input Current (AC line):	0.2A max. at 110 Vac
Input Fuses (AC line, L1 & L2/N):	0.25A fast acting TR5 style
Parameter Ranges	
Distance:	1 to 16,000,000 steps
Speed:	.025 to 100 revolutions per second (up to 25,400 steps/rev.)
Acceleration:	1 to 3000 rev/sec/sec (limited by accel torque)
Deceleration:	1 to 3000 rev/sec/sec (set independently from acceleration)
Time Delays:	0.1 to 25.5 seconds
Output Pulse Widths:	2 to 500 milliseconds
Iterations per loop:	1 to 255
Microstep Resolution:	200-50800 steps/rev
Outputs	
5V:	50 mA used by PIT (if connected) ±5%, 100 mA max, self resetting fuse, Not isolated from internal circuitry
24V:	±5%, 100 mA max, self resetting fuse, Not isolated from internal circuitry
STEP & Dir (logic high):	2.5V min, 3.4V typ, with 20mA load
STEP & Dir (logic low):	0.5V max, 0.3V typ, with 20mA load
STEP output frequency:	50 Hz to 2.54 MHz
STEP output duty cycle:	50%
I/O	
Inputs:	bidirectional, optically isolated, 5-24 Vdc
Input impedance - IN 1-4, CW Jog, CCW Jog, limits:	2200 Ohms
Outputs:	optically isolated, sourcing or sinking
output current (Out 1-3):	100mA max
output voltage (Out 1-3):	24Vdc max
Environment	
Ambient Temp. Range:	32° to 122° F (0 to 50° C)

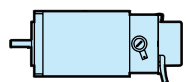

BRUSHED DC

MSC Controller

- Features and Specifications

Axi dyne[®] MSC Controller PROGRAMMING

MSC PROGRAMMING SOFTWARE

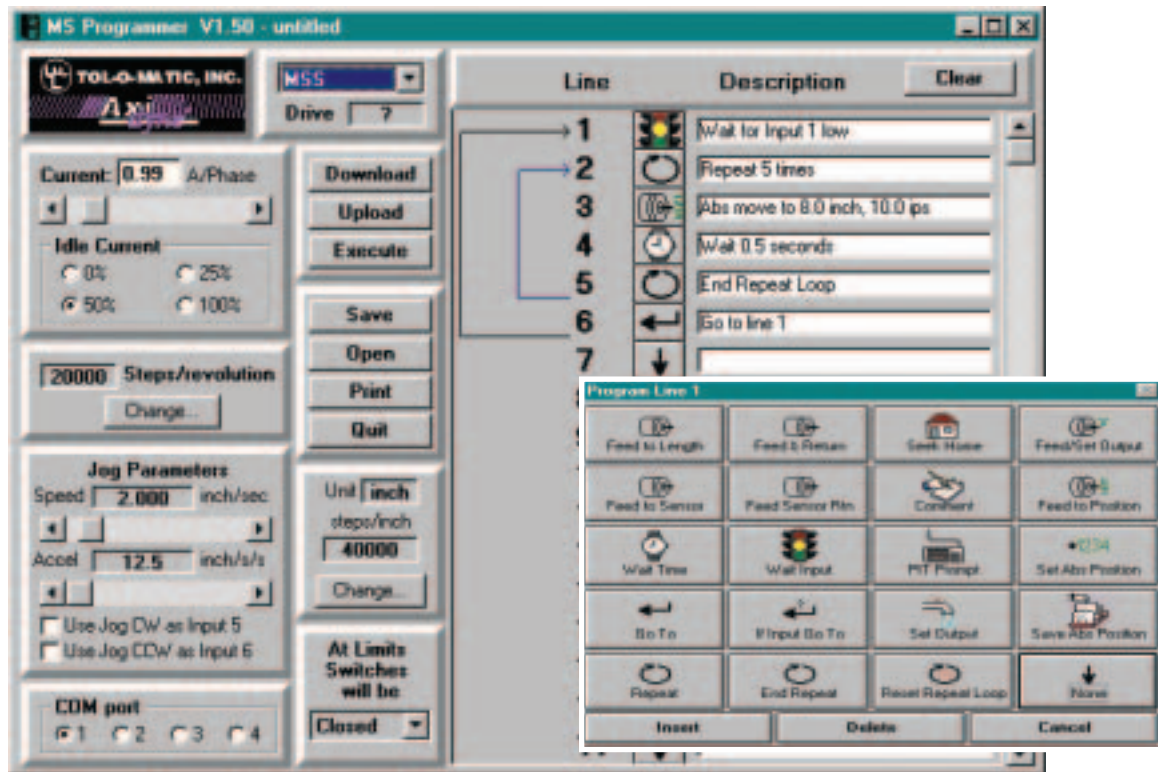

Main Programming Screen

Programmable by RS232 connection to a PC running Windows 95, 98, NT, 2000 or XP. Programming software and cable included. Programming is very easy to learn and requires no previous programming experience.

Programs can be up to 100 lines long. Instructions are powerful, so 100 lines can provide the user with a sophisticated program. For example, in one program line the motor can be moved until a sensor changes state, then fed a precise distance to stop, delayed and returned to the starting point. Distances, delays, feed and return speeds, acceleration and deceleration parameters are all included in the single program instruction. The same move can take 10 program lines or more on other indexers. There are a total of 16 different instructions, including input/output, branches, loops and motion commands. These instructions can be combined to make a nearly infinite variety of programs, meeting the demands of a wide range of applications.

The main programming screen is shown above. On the right of the screen are the 100 program lines. In the center are command buttons and on the left are global parameters such as microstep resolution and jog. Clicking on a program step icon brings up a sequence of dialog boxes, making program selection and parameter setting easy.

Once programmed, the cable can be removed and the indexer-drive will run stand alone. Programs and parameters are stored internally in non-volatile memory. Upon power up, the drive automatically senses the connection to the Windows programming software. If no connection is detected, the program is automatically executed starting on line 1.

The MSS also allows program interaction to take place using the PIT user interface.

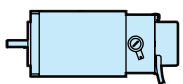

BRUSHED DC

MSC Controller

- Programming

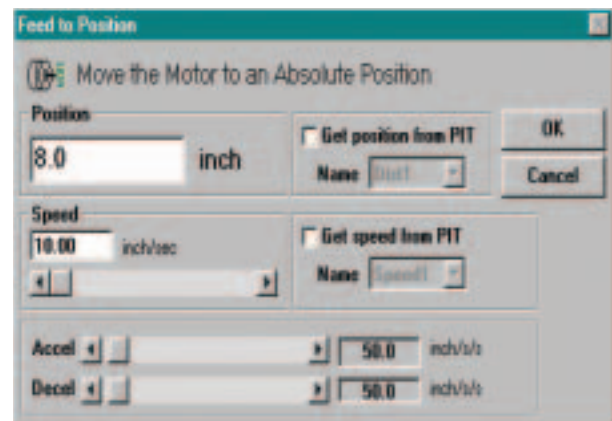

Dialog box for setting Feed to position

Axi dyne[®] MSC Controller

DIMENSIONS

MSC CONTROLLER

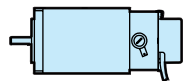
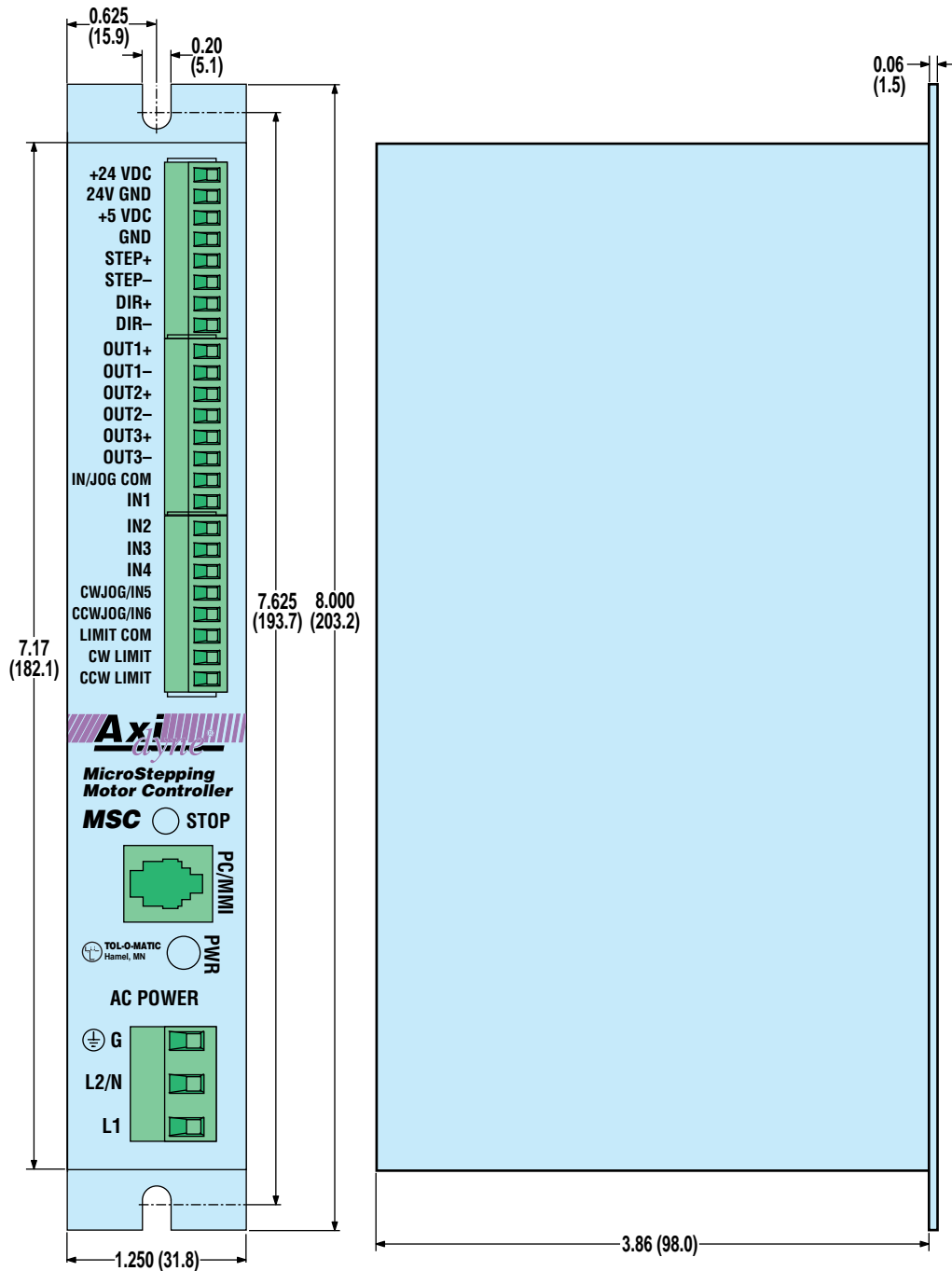

BRUSHED DC

MSC Controller

• Dimensions

Unless otherwise noted, all dimensions shown are in inches (Dimensions in parenthesis are in millimeters)

Axi-dyne® SSC Multi-axis Servo/Stepper Controller

FEATURES

COMPATIBILITY: SYSTEM: BRUSHLESS MOTORS: MRV DRIVE: AXIOM DB
CONTROLLER: SSC
INTERFACE: JS SIT
COMPATIBILITY: SYSTEM: STEPPER MOTORS: MRS DRIVE: MSD
CONTROLLER: SSC
INTERFACE: JS SIT
COMPATIBILITY: SYSTEM: BRUSHED DC MOTORS: MRB DRIVE: AXIOM DB
CONTROLLER: SSC
INTERFACE: JS SIT



The SSC is a high-performance, state-of-the-art motion controller designed for stand-alone operation. This cost effective controller uses a 32-bit microprocessor, a sub-micron gate array, and Tol-O-Motion SSC software, to provide DSP performance without sacrificing ease of use.

Available with up to 4 axes per unit, purchase only the number of axes required. It can simultaneously control stepper and /or servo systems.

Designed to solve complex motion problems with superior precision, the SSC can be used for applications requiring jogging, vector positioning of multi-axis, 2-dimensional linear or circular interpolation, contouring and electronic gearing.

With the Tol-O-Motion SSC software there is no need to learn programming language. Complex motion control is made easy with an interface that streamlines the entire programming process from setup to execution.

SSC FEATURES

- High performance motion control packaged in an industrial enclosure
- Uses a 32-bit specialized microcomputer and custom, submicron gate array for highest performance and speed
- Up to 4 axes per unit — up to 8 units can be daisy-chained
- 125 µsec per axis servo update rate for high bandwidth
- Controls servo motors and/or step motors
- Sophisticated PID filter with velocity and acceleration feed forward for optimum precision
- 16 bit DAC for fine resolution control
- 256K RAM memory for holding and running active program up to 1000 lines x 80 characters
- 4M EEPROM memory for non volatile storage of custom application programs, parameters and arrays (8000 array elements x 30 arrays) — permits stand-alone operation
- Multitasking feature permits simultaneous execution of four independent applications programs
- Programmable acceleration and deceleration with profile smoothing to eliminate jerk
- Continuous vector feed of infinite number of linear and arc segments for smooth motion
- Selectable linear scale simplifies linear motion programming
- Contour mode for profiling along computer generated paths such as parabolic or spherical profiles
- Performs any motion task including jogging, point-to-point positioning, linear and circular interpolation, electronic gearing, cam and contouring
- Dedicated opto-isolated inputs for home, abort, forward and reverse limits — noise immune
- Position feedback for each axis can be from analog signal or encoder
- Auxiliary encoder inputs and dual-loop damping — ideal for backlash compensation
- Programmable event triggers for monitoring elapsed time, position, speed, and motion complete
- I/O functions, timers, and logic functions for executing PLC tasks
- 254 symbolic variables and 8000 element array space for data storage
- Internal, universal switching power supply for direct connection to AC outlet (115V or 230V)
- IDC connectors on front panel connect to DIN rail mounted screw terminal breakouts included
- Additional I/O available on request

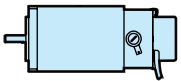

BRUSHED DC

SSC Servo/Stepper Controller

- Features

Axi dyne[®] SSC Multi-axis Servo/Stepper Controller

SPECIFICATIONS

SSC SPECIFICATIONS

Performance	
Servo Loop Cycle Time:	SSC 1: 250 μ sec; SSC 2: 375 μ sec SSC 3: 500 μ sec; SSC 4: 500 μ sec
Block Execution Time:	In contour mode, up to 1000 blocks (moves)/sec with full trajectory calculation
Position Accuracy:	± 1 quadrature count
Velocity Accuracy:	Long-term: phase-locked, better than 0.003% Short-term: system dependent
Synchronization:	All axes in the same unit are perfectly synchronized and share the same servo cycle.
Position Capture Accuracy:	25 μ sec with opto-isolation; 1 μ sec if by-pass opto-isolation.
Parameter Ranges	
Position Range:	$\pm 2,147,483,647$ counts/move; automatic rollover; no limit in jog or vector modes.
Velocity Range:	Up to 8,000,000 counts/sec
Acceleration/deceleration:	1,024 to 67,107,840 c/sec ²
Error Limit:	$\pm 32,767$ counts
Gear Ratio:	± 127.9999
Filter Constants:	Kp: 0 to 1023.875 Kd: 0 to 4095.875 Ki: 0 to 2047.875
Motor Command Resolution:	16-bits or .0003 V
Step Motor Control Mode:	Full, half or microstep
Step Pulse Frequency:	2,000,000 pulse/sec
Number of Variables:	254
Array Memory Size:	8000 elements in up to 30 arrays
Program Memory Size:	1000 lines x 80 characters
Mechanical	
Dimensions:	13" high x 2.5" wide x 6.6" deep
Weight:	6 lbs.
Inputs/Outputs	
Feedback:	Two channels of A/B quadrature per axis with third channel for index. In servo mode, includes auxiliary encoder inputs for each axis. Single ended or differential. Can be configured for quadrature, pulse and direction, or from analog inputs.
General Purpose Inputs:	8 opto-isolated inputs
General Purpose Outputs:	8 TTL outputs
General Purpose Analog Inputs:	7, ± 10 V; 12-bit resolution (16-bit optional)
Dedicated Inputs per Axis:	Forward and reverse limits, home.
Dedicated Outputs per Axis:	Analog motor command, pulse and direction, amplifier enable
Available Power to Drive External Devices	
	+5 V 1.5 Amp +12 V 750 mA -12 V 200 mA
Environment	
Operating Temperature:	32° to 158° F (0° to 70° C)
Communication Interface	
Selectable Baud Rate:	300, 1200, 4800, 9600, 19200, 38400. Handshake mode available.

I/O Description (Inputs)

Encoder, A+, B+:	Position feedback from incremental encoder with two channels in quadrature. The encoder can be (± 12 V) or TTL. Note: Encoders that produce output in a pulse and direction format can also be used.
Encoder Index I+:	Once-per-revolution encoder pulse; used in Homing sequence or Find Index command. Minimum index pulse width is 120 nsec.
Encoder, A-, B-, I-:	Optional differential inputs from encoder; used for enhanced noise immunity.
Auxiliary Encoder:	Inputs for additional encoder; used when encoders on both the motor and the load are required.
Abort #:	Stops commanded motion instantly and also aborts application program.
Reset #:	System reset.
Forward and Reverse Limit Switch #:	When active, inhibits motion in forward or reverse direction and also causes the limit switch subroutine #LIMSWI to execute.
Home Switch #:	Input for Homing (HM) and Find Edge (FE) instructions.
Input 1 - Input 8#:	Uncommitted inputs; can be defined by the user to trigger events or interrupt program.
Latch#:	High-speed position latch to capture axis position within 25 μ sec (bypass opto-isolation for .1 μ sec capture). AL command arms latch. Input 1, 2, 3, 4 latches X, Y, Z, W respectively.
Analog 1 - Analog 7:	Analog inputs that can be connected to external analog signals such as force or pressure transducers. Can also be used for position feedback. 12-bit resolution ADC for ± 10 V input.

I/O Description (Outputs)

Analog Motor Command:	± 10 V range signal for driving servo amplifiers; 16-bit resolution or .0003 V, 3 mA.
Amp enable:	Signal to disable and enable an amplifier. Amp enable goes low when a motor-off condition occurs. For step motors, this pin provides for reduced current when low.
Step Out:	Pulses for input to a step motor driver. The pulses can be either active low or high. Upon Reset, the output will be low if the SM jumper is on, Tristate if off. The STEP OUT pin also provides the PWM signal for servo motors.
Direction:	Used with the STEP OUT signal to give direction to step motors or servo motors in the sign magnitude mode.
Error:	The signal goes low when the position error on any axis exceeds the limit specified by the error command, ER.
Output 1 - Output 8:	These 8 TTL outputs are uncommitted and can be designated by the user to toggle relays and trigger external events. The output lines are toggled by Set Bit (SB), Clear Bit (CB), Define Bit (OB), and OP instructions. Upon reset these signals will be low.

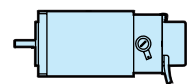

BRUSHED DC

SSC Servo/Stepper Controller

- Specifications

Axi-dyne[®] SSC Multi-axis Servo/Stepper Controller

CONNECTORS

SSC CONNECTORS

SSC J2 Main; 60-Pin IDC;

1 Ground	2 5V		
3 Error	4 Reset		
5 Switch Common	6 Forward Limit - X		
7 Reverse Limit - X	8 Home - X		
9 Forward Limit - Y	10 Reverse Limit - Y		
11 Home - Y	12 Forward Limit - Z		
13 Reverse Limit - Z	14 Home - Z		
15 Forward Limit - W	16 Reverse Limit - W		
17 Home - W	18 Output 1		
19 Input Common	20 Latch X or Input 1		
21 Latch Y or Input 2	22 Latch Z or Input 3		
23 Latch W or Input 4	24 Abort Input		
25 Motor Command X	26 Amp Enable X		
27 Motor Command Y	28 Amp Enable Y		
29 Motor Command Z	30 Amp Enable Z		
31 Motor Command W	32 Amp Enable W		
33 A+ X	34 A- X	35 B+ X	36 B- X
37 I+ X	38 I- X	39 A+ Y	40 A- Y
41 B+ Y	42 B- Y	43 I+ Y	44 I- Y
45 A+ Z	46 A- Z	47 B+ Z	48 B- Z
49 I+ Z	50 I- Z	51 A+ W	52 A- W
53 B+ W	54 B- W	55 I+ W	56 I- W
57 +12V	58 -12V	59 5V	60 Ground

SSC J5 General I/O; 26-Pin IDC;

1 Analog 1	2 Analog 2
3 Analog 3	4 Analog 4
5 Analog 5	6 Analog 6
7 Analog 7	8 Ground
9 5V	10 Output 1
11 Output 2	12 Output 3
13 Output 4	14 Output 5
15 Output 6	16 Output 7
17 Output 8	18 Input 8
19 Input 7	20 Input 6
21 Input 5	22 Input 4 (Latch W)
23 Input 3 (Latch W)	24 Input 2 (Latch W)
25 Input 1 (Latch W)	26 Input Common (isolated 5V)

SSC J3 Auxiliary Encoder; 20-Pin IDC;

1 Sample Clock	2 Reserved
3 B- Aux W	4 B+ Aux W
5 A- Aux W	6 A+ Aux W
7 B- Aux Z	8 B+ Aux Z
9 A- Aux Z	10 A+ Aux Z
11 B- Aux Y	12 B+ Aux Y
13 A- Aux Y	14 A+ Aux Y
15 B- Aux X	16 B+ Aux X
17 A- Aux X	18 A+ Aux X
19 5V	20 Ground

SSC J4 Driver; 20-Pin IDC;

1 Motor Command X	2 Amp Enable X
3 PWM X/Step X	4 Sign X/Dir X
5	6 Motor Command Y
7 Amp Enable Y	8 PWM Y/Step Y
9 Sign Y/Dir Y	10
11 Motor Command Z	12 Amp Enable Z
13 PWM Z/Step Z	14 Sign Z/Dir Z
15 5V	16 Motor Command W
17 Amp Enable W	18 PWM W/Step W
19 Sign W/Dir W	20 Ground

AC Power Inputs; 4-PIN Detachable Screw Type:

Hot Connects to 110 or 220 AC

NC No Connect

Neutral Return for AC

Earth Chassis input

RS232 - Main Port; 9-PIN:

1 CTS - output	2 Transmit data
3 Receive data	4 RTS - input
5 Ground	6 CTS - output
7 RTS - input	8 CTS - output
9 5V	

RS232 - Auxiliary Port; 9-PIN:

1 CTS - input	2 Receive data -
3 Transmit data	4 RTS - output
5 Ground	6 CTS - input
7 RTS - output	8 CTS - input
9 5V	

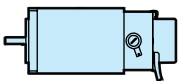

BRUSHED DC

SSC
Servo/Stepper
Controller

• Connectors

Axi-dyne[®] SSC Multi-axis Servo/Stepper Controller

PROGRAMMING SOFTWARE

SSC PROGRAMMING SOFTWARE

Programming is accomplished through RS232 connection to a PC running Windows 95, 98, NT, 2000 or XP. Visual Basic panels guide the user through the complete setup process including communications and axis configuration. The user can then use other program options including Display, Jog, Teach, Programmer, Tune and Data Acquisition.

Display

The Display panel (shown above) allows the user to identify axis locations and status faults, limits, and I/O.

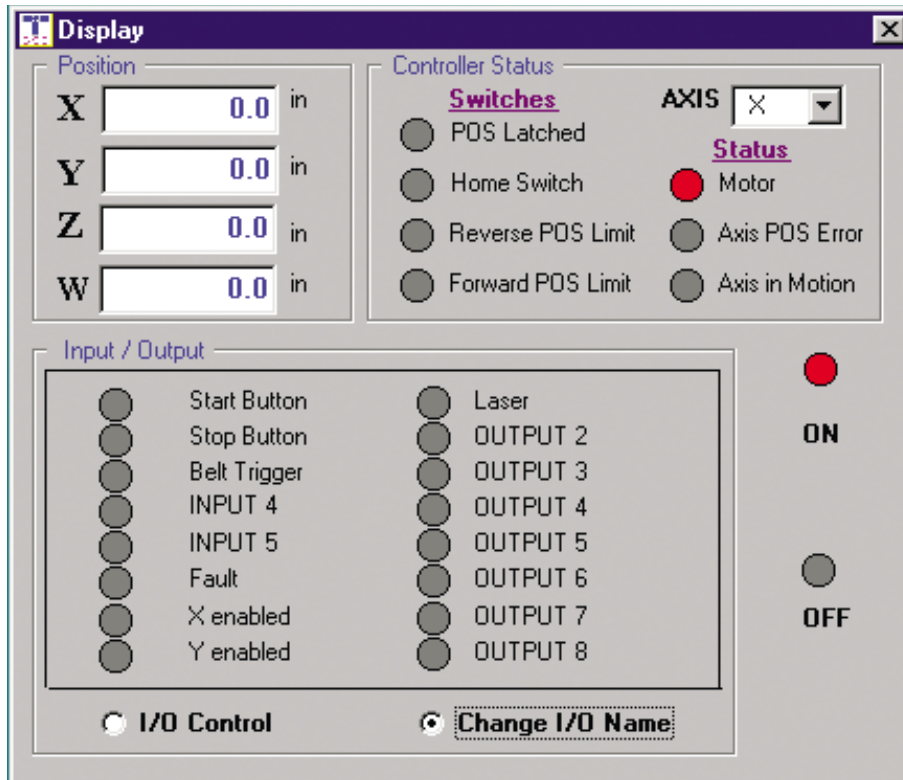

Jog

The Jog panels allow the user to easily setup independent motion or coordinated motion.

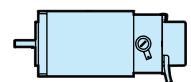

BRUSHED DC

SSC Servo/Stepper Controller

- Programming

Axi-dyne® SSC Multi-axis Servo/Stepper Controller

PROGRAMMING SOFTWARE

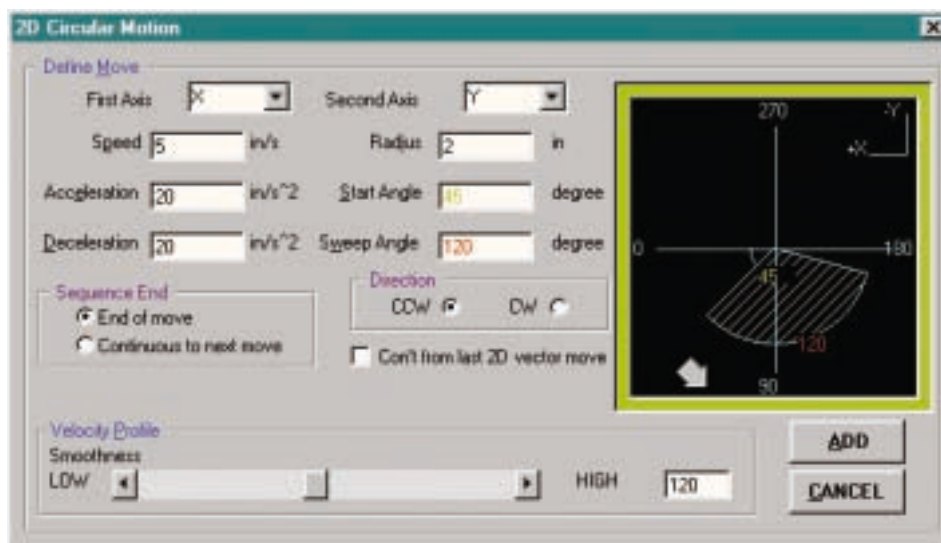

CIRCULAR MOTION

The added feature of 2-dimensional circular programming, assists you in selecting start and sweep angles.

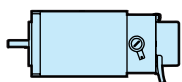

BRUSHED DC

SSC
Servo/Stepper
Controller

- Programming

Axi-dyne[®] SSC Multi-axis Servo/Stepper Controller

DIMENSIONS

SSC (MULTI-AXIS SERVO/STEPPER CONTROLLER)

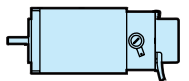
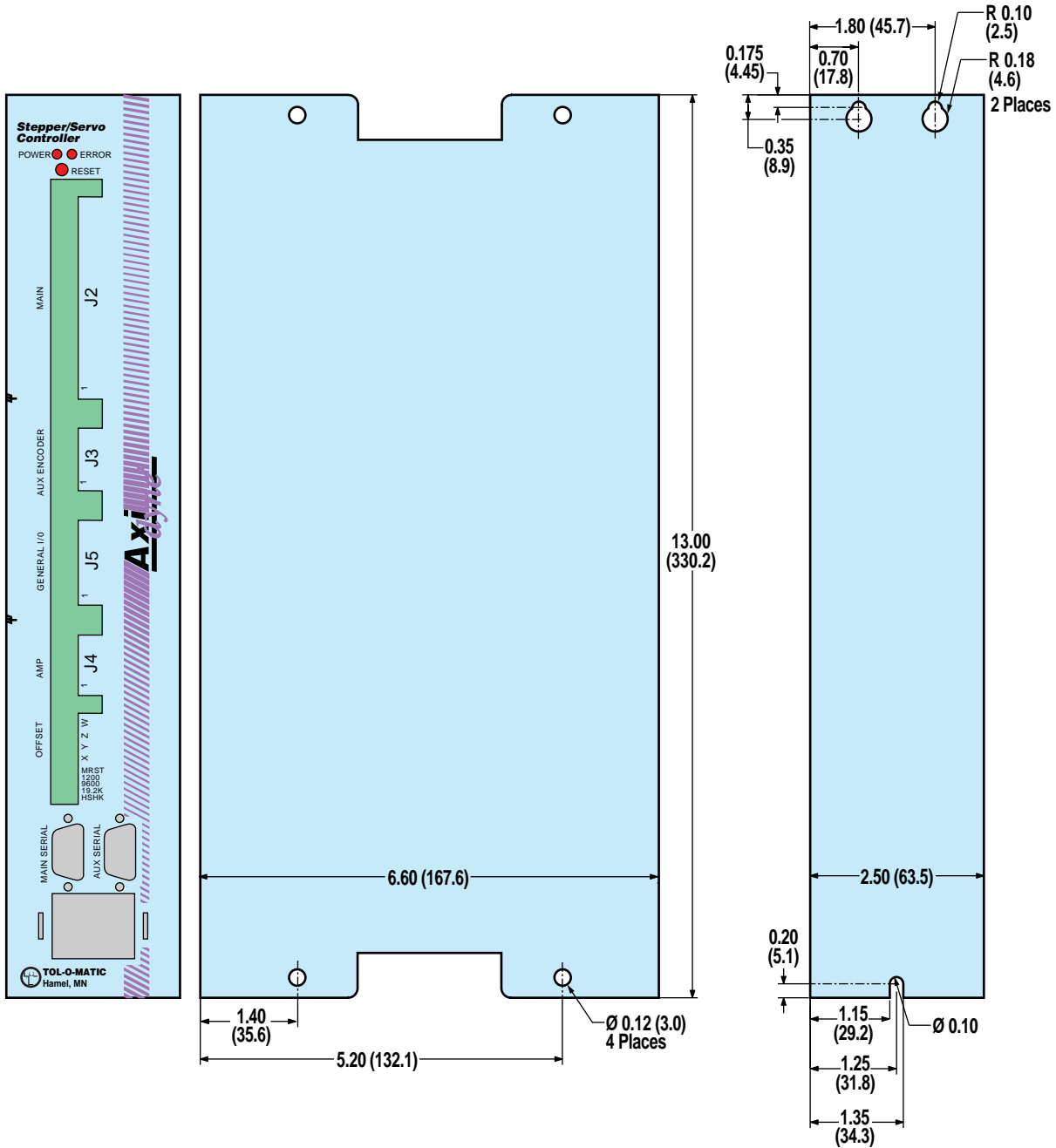

BRUSHED DC

SSC Servo/Stepper Controller

• Dimensions

Unless otherwise noted, all dimensions shown are in inches (Dimensions in parenthesis are in millimeters)

Axi-dyne® PIT – Panel Mount User Interface

FEATURES, SPECIFICATIONS AND DIMENSIONS

COMPATIBILITY:
 SYSTEM: STEPPER
 MOTORS: MRS
 DRIVE: MSS
 CONTROLLER: MSS
 INTERFACE: PIT

COMPATIBILITY:
 SYSTEM: BRUSHED DC
 MOTORS: MRB
 DRIVE: AXIOM DB
 CONTROLLER: MSC
 INTERFACE: PIT



User interaction with the MSS is simple with the PIT panel mount user interface. The Tol-O-Motion MS software allows visual setup of the panel to status the user on a particular action taking place, or to prompt the user to make a decision or provide information such as move distance, move speed, repeat count.

FEATURES

- Flush or surface mounting
- Four line by 20 character LCD display
- RS232 communication to MSS controllers
- Uses RS232 cable supplied with MSS controllers

CABLES

Motor cable and encoder cable are included when ordering MSS controllers (see page H-25)

PIT (PANEL MOUNT USER INTERFACE) DIMENSIONS

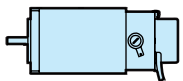

BRUSHED DC

PIT Panel Mount User Interface

- Features
- Specifications
- Dimensions

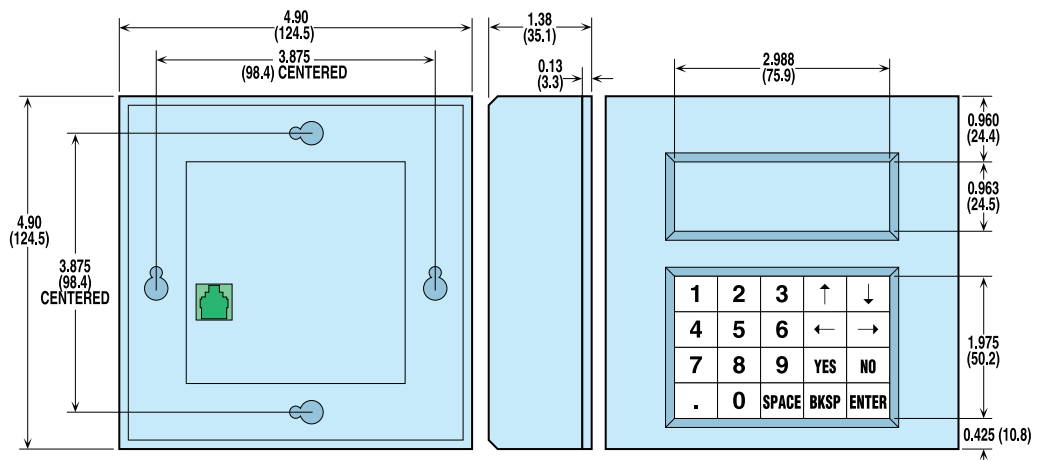

Unless otherwise noted, all dimensions shown are in inches (Dimensions in parenthesis are in millimeters)

Axi dyne® JS – Joystick User Interface

SPECIFICATIONS AND DIMENSIONS

COMPATIBILITY:
SYSTEM: BRUSHLESS
MOTORS: MRV
DRIVE: AXIOM DB
CONTROLLER: SSC
INTERFACE: JS
SIT

COMPATIBILITY:
SYSTEM: STEPPER
MOTORS: MRS
DRIVE: MSD
CONTROLLER: SSC
INTERFACE: JS
SIT

COMPATIBILITY:
SYSTEM: BRUSHED DC
MOTORS: MRB
DRIVE: AXIOM DB
CONTROLLER: SSC
INTERFACE: JS
SIT



For simple setup of the SSC controller the JS joystick provides 2-axis manipulation. Used with the Joystick Teach mode of the Tol-O-Motion SSC software, moves can be made with velocity control, and then stored using a separate button integrated into the joystick housing.

SPECIFICATIONS	JS Joystick
Joystick Travel	27° from design center in all directions
Mechanical Life Cycle	5 million (minimum)
Trim Movement (Optional)	±7° (total trim 14°) for each axis
Main Ball Pivot	Precision ground stainless steel
Stick Shaft	3/16" brass plated
Potentiometers	Set at center of resistance
Potentiometer Calibration	Thumb tab provides up to 114° of potentiometer calibration
Return to Center Repeatability	±1%
Deflection Force	0.14 lbs. at 27° at 2-7/8" from pivot point
Switches	2 elongated push-button switches
Cable	Integrated 7' (2.1m) cable with strain relief

JS (JOYSTICK) DIMENSIONS

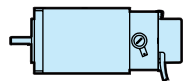
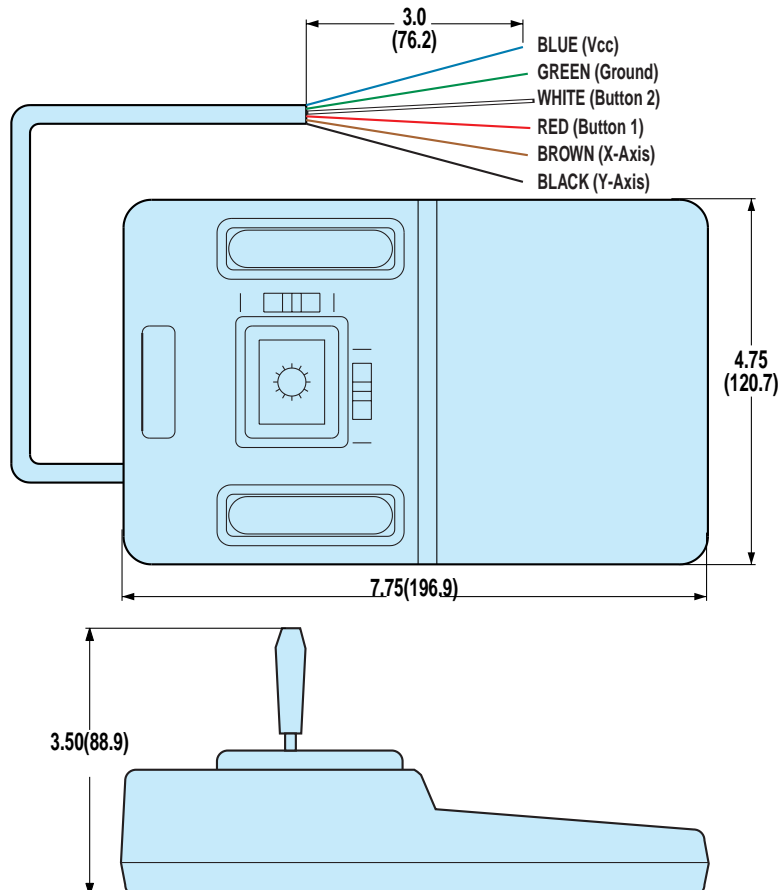

BRUSHED DC

**Js Joystick
User Interface**

- Specifications
- Dimensions

Axi dyne® SIT – Hand-held User interface

FEATURES, SPECIFICATIONS AND DIMENSIONS

COMPATIBILITY:
SYSTEM: BRUSHLESS
MOTORS: MRV
DRIVE: AXIOM DB
CONTROLLER: SSC
INTERFACE: JS
SIT

COMPATIBILITY:
SYSTEM: STEPPER
MOTORS: MRS
DRIVE: MSD
CONTROLLER: SSC
INTERFACE: JS
SIT

COMPATIBILITY:
SYSTEM: BRUSHED DC
MOTORS: MRB
DRIVE: AXIOM DB
CONTROLLER: SSC
INTERFACE: JS
SIT



For user interaction with the SSC 1-4 axis multi-function controllers the SIT hand held user interface provides flexibility and setup simplicity. The Tol-O-Motion SS software (included with the SSC 1-4 controllers) has a setup page for use with the SIT to allow the controller to status the user, or to prompt the user for information, eliminating the need for a PC following setup.

FEATURES:

- 45 key, alpha-numeric tactile keypad
- 4 row by 20 character LCD display
- Rugged, high impact ABS housing
- 7 foot (2.1m) RS232 cable with 9-pin “D” connector for connection to the SSC 1-4
- 5 Vdc power supplied from SSC 1-4 controller over RS232

SPECIFICATIONS JS Joystick

Weight	8.0 oz. (.23 Kg.)
Character Set	ASCII with upper case transmit, upper and lower case receive
Case	Molded, high impact ABS with retractable hanger
Keypad	15 user-programmable function keys
Display	Transreflective LCD with 5 by 7 character font
Power Requirements	30 mA maximum, regulated, 5 Vdc \pm 5% (Received through RS 232 cable)
Speaker	Audible key click, bell and alert
Storage Temperature	-4° F (-20° C) to 158° F (+70° C)
Operating Temperature	32°F (0° C) to 122° F (+50° C)
Relative Humidity	10% to 90% non-condensing

SIT (HAND-HELD INTERFACE)

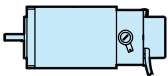

BRUSHED DC

SIT Hand-held User Interface

- Features
- Specifications
- Dimensions

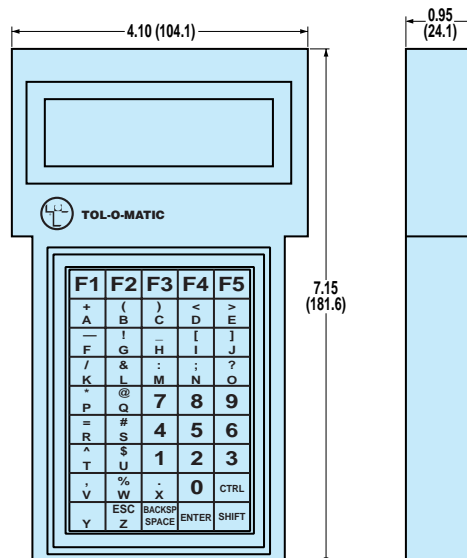

Axi-dyne® Brushed dc Systems

CABLES

MRB MOTORS TO AXIOM DB DRIVE

MRB21, MRB31, MRB32
MRB41, MRB42



TO:

AXIOM DB

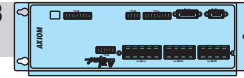

Config Code	Replacement Part Number	Included with Motor	Type	Description	Cable Length	Motor Sizes	CONNECTORS AT Motor	AT Drive	Drive Sizes
-	-	YES	Power		0.6m	All	Flying leads	Screw terminals	Axiom DB20
-	-	YES	Encoder		0.5m	All	Flying leads	Screw terminals	Axiom DB20

AXIOM DB DRIVE TO SSC CONTROLLER

AXIOM DB20

TO:

SSC

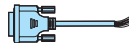
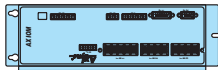

BREAKOUT BOX

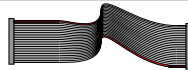

RIBBON CABLE



Config Code	Replacement Part Number	Included with SSC	Type	Description	Cable Length	Drive Sizes	CONNECTORS AT Drive	AT SSC	SSC Size
-	3600-1347	YES	Main/Driver	Ribbon	1m	All	Screw terminals	IDC	All
-	3600-1342	YES	Signals	Breakout					
-	3600-1346	YES	I/O	Ribbon	1m	All	Screw terminals	IDC	All
-	3600-1341	YES	Breakout						
-	3604-1213	YES	Controller Encoder		3m	All	DB15	Screw terminals at breakout box	All

SSC CONTROLLER TO IBM COMPATIBLE PC

SSC



CRZ

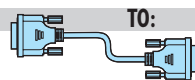

TO:

PC



Config Code	Replacement Part Number	Included with SSC	Type	Description	Cable Length	SSC Size	CONNECTORS AT SSC	AT PC	PC Size
CRZ	3600-1172	Optional	Comm		1m	All	DB9	DB9	All

AXIOM DB DRIVE TO MSC CONTROLLER

AXIOM DB20

TO:

MSC

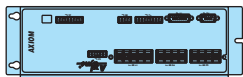

Config Code	Replacement Part Number	Included	Type	Description	Cable Length	Drive Size	CONNECTORS AT Axiom DB	AT MSC	MSC Size
-	-	Cust. supplied		22-26 gauge		All	Screw terminal	Screw terminal	All

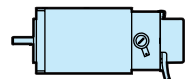

BRUSHED DC

Cables

MSC CONTROLLER TO IBM COMPATIBLE PC

MSC

TO:

PC

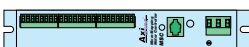

Config Code	Replacement Part Number	Included with MSC	Type	Description	Cable Length	MSC Size	CONNECTORS AT MSC	AT PC	PC Size
-	-	YES	Comm		2m	All	RJ11	DB9	All

Axi dyne® Brushed dc System

ORDERING

MOTOR STYLE, SIZE AND GEARHEAD REDUCTION

M R B 3 1 Y **G H J 3 1**

MOTOR TYPE
MRB Brushless Servo Motor

MOTOR SIZE / DRIVE SIZE

MODEL	FRAME SIZE	STACK SIZE	DRIVE SIZE
21Y	23	1	Axiom DB20
31Y	34	1	Axiom DB20
32Y	34	2	Axiom DB20
41Y	40	1	Axiom DB20
42Y	40	2	Axiom DB20

Once motor type and frame size is selected, the appropriate adapter and couplers required are automatically chosen.

NO DRIVE OPTION
X Replace Y with X if motor drive is NOT required (do not put 'Y' in string)

NO MOTOR OPTION
XY* Motor(s) supplied by customer, Tol-O-Matic to mount using standard hardware and couplers
XJ* Motor(s) supplied and mounted by customer, Tol-O-Matic to furnish standard hardware and couplers

* For XY and XJ options, a full endface and shaft dimensional drawing must accompany the order for the actuator. Customer motors must be directly interchangeable with Tol-O-Matic motors.

GEARHEAD REDUCTIONS
(For In-line or Direct-Drive mounting configurations only)

MODEL	INPUT DIA.	MOTOR SIZE	REDUCTION RATIO
GHK20	1/4-inch	23	5.5
GHJ20	1/2-inch	23	5.5
GHJ21	1/2-inch	23	10
GHJ30	1/2-inch	34	5.5
GHJ31	1/2-inch	34	10

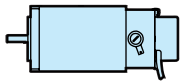

BRUSHED DC

System Ordering

CONTROLLER

S S C 3 4

CONTROLLER

SINGLE AXIS APPLICATIONS
MSC Single Axis Controller
SSC10 **Stepper/Servo Controller, 1 axis application

MULTI AXIS APPLICATIONS

2 Axis Application

	1st Axis	2nd Axis
SSC21	Servo	Stepper
SSC22	Servo	Servo

3 Axis Application

	1st Axis	2nd Axis	3rd Axis
SSC31	Servo	Stepper	Stepper
SSC32	Servo	Stepper	Servo
SSC33	Servo	Servo	Stepper
SSC34	Servo	Servo	Servo

4 Axis Application

	1st Axis	2nd Axis	3rd Axis	4th Axis
SSC41	Servo	Stepper	Stepper	Stepper
SSC42	Servo	Stepper	Stepper	Servo
SSC43	Servo	Stepper	Servo	Stepper
SSC44	Servo	Stepper	Servo	Servo
SSC45	Servo	Servo	Stepper	Stepper
SSC46	Servo	Servo	Stepper	Servo
SSC47	Servo	Servo	Servo	Stepper
SSC48	Servo	Servo	Servo	Servo

CABLES

MRB motors have flying leads, special cables are not required.

For SSC Controllers
CRZ If a 2-meter 9-pin RS232 cable is desired

If ordering with AXIOM drive, controller encoder cables are included for each axis.

Indicate if breakout terminal and ribbon cables are needed.

BON No breakout terminals
BOY*** With breakout terminals

***BOY option includes:

- 60 pin/18" (457mm) ribbon cable & 60 pin breakout
- 26 pin/18" (457mm) ribbon cable & 26 pin breakout
- If any axis configured w/ step & direction output — 20 pin/18" (457mm) ribbon cable & 20 pin breakout

CABLES, CONNECTIONS & INTERFACE

C R Z **B O Y** **S I T**

USER INTERFACE

PIT Panel mount interface (for use with MSC)
SIT Hand-held user interface
JS Joy Stick



Not all codes listed are compatible with all options.

Use the Tol-O-Motion™ Sizing Software to determine available options and accessories based on your application requirements.

User manuals and software CD-ROM is included with any controller or drive ordered. Manuals and software are also available for download at www.tolomatic.com

TO ORDER ACTUATORS

- B3S/M3S SERIES (SEE PAGE C-30)**
- B3B/M3B SERIES (SEE PAGE C-50)**
- TKS SERIES (SEE PAGE C-82)**
- TKB SERIES (SEE PAGE C-104)**
- BCS/MCS SERIES (SEE PAGE C-128)**
- SLS/MLS SERIES (SEE PAGE C-138)**
- RSA/RSM SERIES (SEE PAGE D-53)**
- GSA/GSM SERIES (SEE PAGE E-36)**

Axi dyne® Brushed dc System

FIELD RETROFIT ORDERING

*SSC I-4 CONTROLLERS

Code	X-Axis	Y-Axis	Z-Axis	W-Axis	Part #
SSC10	Servo	-	-	-	3600-0210
SSC21	Servo	Stepper	-	-	3600-0221
SSC22	Servo	Servo	-	-	3600-0222
SSC31	Servo	Stepper	Stepper	-	3600-0231
SSC32	Servo	Stepper	Servo	-	3600-0232
SSC33	Servo	Servo	Stepper	-	3600-0233
SSC34	Servo	Servo	Servo	-	3600-0234
SSC41	Servo	Stepper	Stepper	Stepper	3600-0241
SSC42	Servo	Stepper	Stepper	Servo	3600-0242
SSC43	Servo	Stepper	Servo	Stepper	3600-0243
SSC44	Servo	Stepper	Servo	Servo	3600-0244
SSC45	Servo	Servo	Stepper	Stepper	3600-0245
SSC46	Servo	Servo	Stepper	Servo	3600-0246
SSC47	Servo	Servo	Servo	Stepper	3600-0247
SSC48	Servo	Servo	Servo	Servo	3600-0248

NOTE: Any axis of the SSC may be changed by the insertion or removal of a jumper, see SSC manual #3600-4608

*Includes user manual and software CD-ROM

*MSC CONTROLLER

Item	Part #
MSC Single Axis Controller	3600-0040

*Includes user manual and software CD-ROM

CABLES

Item	Part #
20 pin breakout	3600-1340
26 pin breakout	3600-1341
60 pin breakout	3600-1342
20 pin ribbon cable	3600-1345
26 pin ribbon cable	3600-1346
60 pin ribbon cable	3600-1347
SSC Encoder cable	3604-1213

*AXIOM DB DRIVE

Config. Code	Part #
DB20 cables are included as motor flying leads	3604-0003

*Includes user manual and software CD-ROM

CABLES

—	Controller Encoder Cable	3604-1213
CRZ	RS232 Cable	3600-1172

MRB BRUSHED DC MOTORS

Config. Code	Part #
MRB21	3600-6248
MRB31	3600-6249
MRB32	3600-6250
MRB41	3600-6251
MRB42	3600-6252

** For RSA Rod Screw Actuators only

USER INTERFACES

Config. Code	Part #
PIT	3600-9607
SIT	3600-9161
JS	3600-9162



BRUSHED DC

**Field Retrofit
Ordering**

FIELD RETROFIT ORDERING



BRUSHLESS (SEE PAGE F-34)



STEPPER (SEE PAGE G-24)

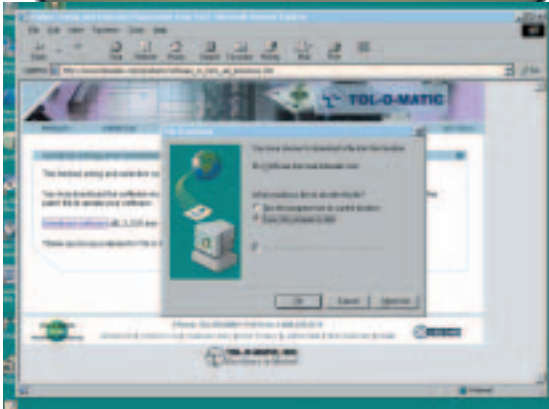

You don't have the luxury of playing games. You need software that does what you expect and that is up and running without any hassles. Tol-O-Motion software is programmed to be the most straightforward method to:

- 1) Determine the correct motion control system for your application.
- 2) Control the drives, motors and actuators in your motion control system.

For your convenience a CD-ROM is included with each system sold that includes:

- Complete operating manual in Adobe Acrobat® format (printed manual is included as well)
- Tol-O-Motion programming software
- Tol-O-Motion sizing & selection software

BUT WHY WAIT?

You can download all this and more (including CAD files, parts sheets, distributor information) at our web site:

TOLOMATIC.COM

NO NEED TO MIX-AND-MATCH COMPONENTS

With Axidyne, you don't need to mix-and-match components and cross your fingers. All our system components are designed to work together — controls, drives, motors and actuators — complete with all cables and accessories for easy setup and installation.

NO NEED TO SPEND HOURS CALCULATING WHICH ACTUATOR AND MOTOR TO USE.

Axidyne Tol-O-Motion™ Sizing and Selection Software makes it easy to choose the right components for your applications. User friendly Windows based software guides you through the selection process, offering several options to choose from.

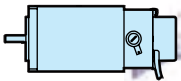

BRUSHED DC

YOU GET A SINGLE-SOURCE SOLUTION ENGINEERED SPECIFICALLY FOR YOUR APPLICATION, BUILT-TO-ORDER IN 5 DAYS OR LESS.



- DC REED
- DC HALL-EFFECT
- ACTRIAC
- QUICK-DISCONNECT COUPLERS
- SWITCH KITS

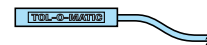

SWITCHES

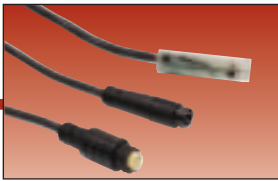

Axi-dyne® Switches OVERVIEW

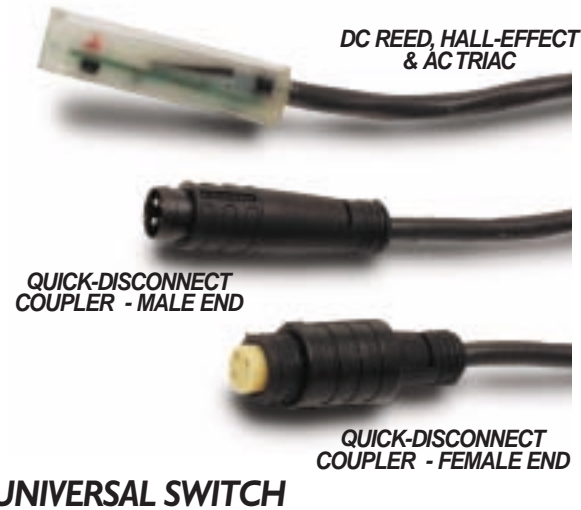

UNIVERSAL SWITCH

Commonly used for end-of-stroke signalling to programmable controllers and homing sensors, these switches are activated by the actuator's internal magnet.

If necessary to remove factory installed switches, be sure to reinstall on the same of side of actuator with scored face of switch toward internal magnet.

Switches contain reverse polarity protection. Switch cable is UNSHIELDED for switches that DO NOT incorporate the quick-disconnect feature. *Switches with quick-disconnect coupler feature have SHIELDED cable from the female quick-disconnect coupler to the flying leads.* Shield should be terminated at flying lead end.

DC REED AND AC TRIAC SWITCHES

These are mechanical switches designed for signalling position to devices such as programmable logic controllers.

DC HALL-EFFECT SWITCHES

Available in either sinking type (NPN), or sourcing type (PNP). These solid-state switches are designed to signal devices such as programmable controllers, dc loads, and TTL or CMOS circuits.



* 197" (5M) LENGTH, QUICK-DISCONNECT COUPLER IS POSITIONED 6" FROM THE SENSOR

THE SCORED FACE OF THE SWITCH INDICATES THE SENSING SURFACE AND MUST FACE TOWARD THE MAGNET.

THE NOTCHED GROOVE IN THE ACTUATOR INDICATES THE SIDE WITH THE MAGNET. CONTACT TOL-O-MATIC IF SWITCHES ARE REQUIRED ON BOTH SIDES OF ACTUATOR.

CAUTION: DO NOT OVER TIGHTEN SWITCH HARDWARE WHEN INSTALLING!

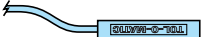

SWITCHES

Overview



DC REED SWITCH FORM A AND FORM C SPECIFICATIONS

RESISTANCE	0.1 Ω Initial (Maximum)	
RELEASE TIME	1.0 msec. maximum	
OPERATING TEMP.	-40° F (-40 C) to 158° F (70° C)	
CABLE MINIMUM	5m CABLE with PVC jacket: 0.630" static, dynamic not recommended	
BEND RADIUS	5m Quick-Disconnect style CABLE with PVC jacket: 0.630" static, 1.260" dynamic	
LIFE EXPECTANCY	Up to 200,000,000 cycles (depending on load current, duty cycle and environmental conditions)	
	FORM A	FORM C
CONTACTS	Single-pole, single-throw, normally-open	Single-pole, double-throw, normally-open / normally-closed
CONTACT RATING	10 Watts, maximum current 500mA (not to exceed 10VA) (Refer to Temperature vs. Current and Voltage Derating charts.)	3 Watts, maximum current 250mA (not to exceed 3VA) (Refer to Temperature vs. Current and Voltage Derating charts.)
VOLTAGE DROP	2.6V typical @ 100mA	NA
INPUT VOLTAGE	200Vdc maximum	120Vdc maximum
OPERATING TIME	0.6 msec. maximum (including bounce)	0.7 msec. maximum (including bounce)
INDICATOR	Red LED lit when 4mA min. (at 24V) flows through contacts	None

FORM A REED SWITCH: WIRING

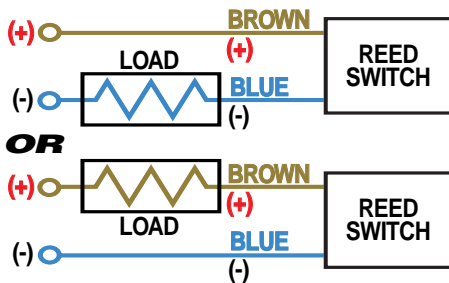

FORM C REED SWITCH: WIRING

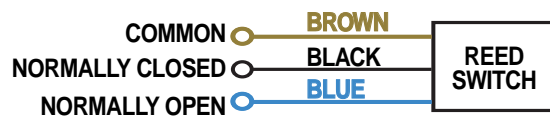

FORM A REED SWITCH: TEMPERATURE VS CURRENT

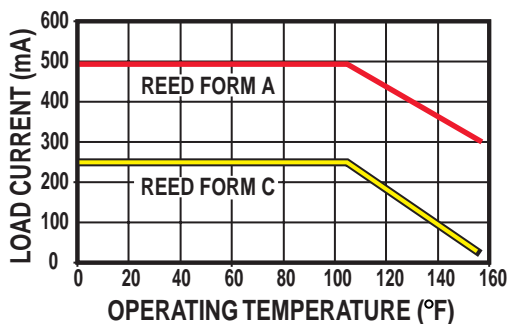

FORM C REED SWITCH: TEMPERATURE VS CURRENT

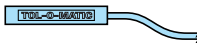
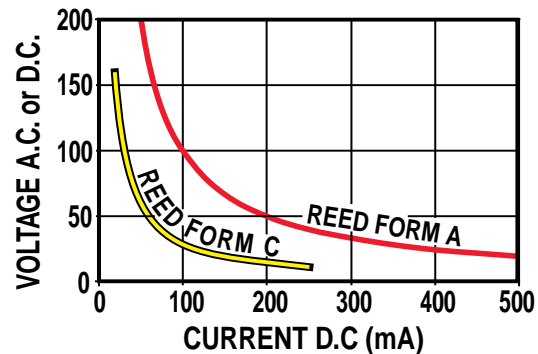

SWITCHES

Specifications

- Dc reed

HALL-EFFECT SWITCH SPECIFICATIONS

INPUT VOLTAGE	5 to 25Vdc
OUTPUT	Open collector transistor switch
OUTPUT RATING	25Vdc, 200mA dc
ON TRIP POINT	150 Gauss maximum
OFF TRIP POINT	40 Gauss minimum
OPERATING TEMP.	0° F (-18 C) to 150° F (66° C)
OPERATING SPEED	<10 micro sec..
INDICATOR	Red LED lit when sensor is activated
CABLE MINIMUM	5m CABLE with PVC jacket: 0.630" static, dynamic not recommended
BEND RADIUS	5m Quick-Disconnect style CABLE with PVC jacket: 0.630" static, 1.260" dynamic

HALL-EFFECT SOURCING SWITCH: WIRING

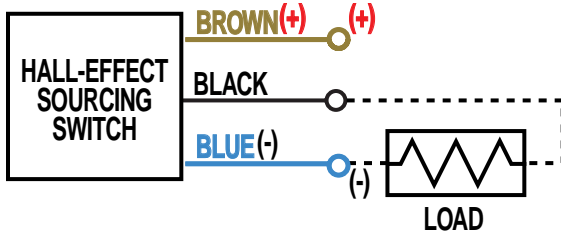

HALL-EFFECT SINKING SWITCH: WIRING

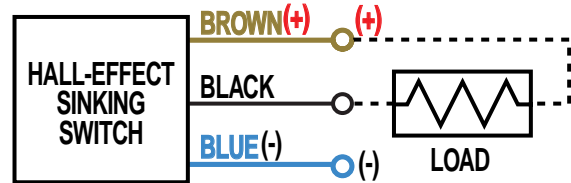

AC TRIAC SWITCH SPECIFICATIONS

CONTACTS	Single-pole, single-throw, normally-open
INPUT VOLTAGE	120Vac maximum
FREQUENCY	47 - 63 Hz
CONTINUOUS CURRENT	1 Amp at 86° F (30° C)
CURRENT	0,5 Amp at 140° F (60° C)
PEAK SURGE CURRENT	10 Amp
OPERATING TEMP.	-40° F (-40 C) to 158° F (70° C)
INDICATOR	None
CABLE MINIMUM	5m CABLE with PVC jacket: 0.630"(16mm) static, dynamic not recommended
BEND RADIUS	5m Quick-Disconnect style CABLE with PVC jacket: 0.630"(16mm) static, 1.260 (32mm) dynamic
LIFE EXPECTANCY	Up to 200,000,000 cycles (depending on load current, duty cycle and environmental conditions)

AC TRIAC SWITCH: WIRING

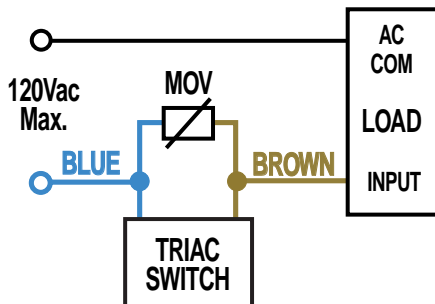

AC TRIAC SWITCH: TEMPERATURE VS CURRENT

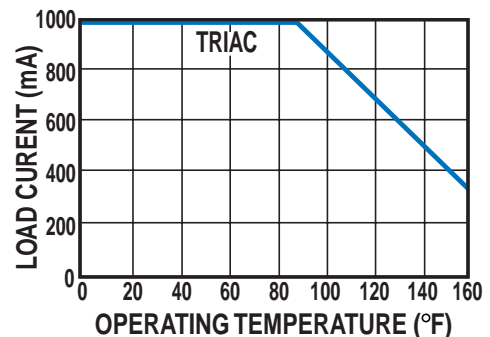

SWITCHES

Specifications

- Hall-effect
- Ac triac

QUICK-DISCONNECT COUPLERS



Quick-disconnect couplers are available for all switches in 197" (5m) length. These couplers allow switches to be removed quickly and easily. Switch includes one male-end coupler (hard wired to switch) and one female-end coupler with additional cable for in-line splice. Replacement switch with hard-wired male-end connector is available as a service part.

Note: Quick-disconnect coupler is positioned 6" (152mm) from the sensor.

Not compatible with TruTrack actuators

IMPORTANT NOTE:

An important note regarding field retrofit of quick-disconnect couplers: If replacing a quick-disconnect switch manufactured before 7-1-97 it will also be necessary to replace or rewire the female-end coupler with the in-line splice.

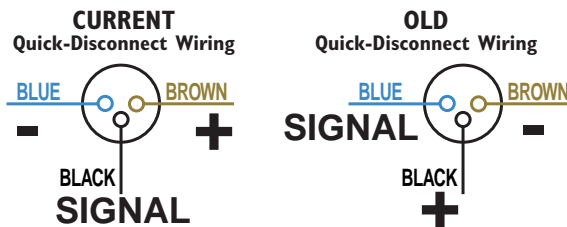

SP (SENSOR PACKAGE) TRUTRACK SWITCH KITS

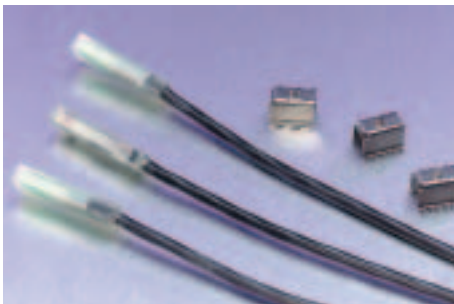

These kits contain 2 form C Reed and 1 Hall-effect sinking switch with 5m leads and necessary mounting hardware. Switches on TruTrack actuators are mounted internally on the tube extension, encasing both switch and wire for a neat compact package.

NOTE:

When configured with initial order, the 2 form C Reed switches (limit sensors) will be set at factory 1" (25mm) from the end of stroke. The 1 sinking Hall-effect switch (home sensor) will be set 2" (51mm) from the end of stroke on the motor end. Switches are easily adjusted for specific applications.

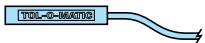

SWITCHES

Couplers and Kits

- Quick-disconnect couplers
- TruTrack sensor package

SWITCH KIT AVAILABILITY

ACTUATOR MODEL								Switch Config. Code	Switch Description
B3S M3S	B3B M3B	BCS MCS	SLS MLS	RSA RSM	GSA GSM	TKS	TKB		
•	•	•	•	•	•	•	•	BT	Reed, Form C, 5m lead
•	•	•	•	•	•	—	—	BM	Reed, Form C, 5m quick-disconnect lead
•	•	•	•	•	•	•	•	RT	Reed, Form A, 5m lead
•	•	•	•	•	•	—	—	RM	Reed, Form A, 5m quick-disconnect lead
•	•	•	•	•	•	•	•	KT	Hall-effect, Sinking, 5m lead
•	•	•	•	•	•	—	—	KM	Hall-effect, Sinking, 5m quick-disconnect lead
•	•	•	•	•	•	•	•	TT	Hall-effect, Sourcing, 5m lead
•	•	•	•	•	•	—	—	TM	Hall-effect, Sourcing, 5m quick-disconnect lead
•	•	•	•	•	•	—	—	CT	ac Triac, 5m lead
•	•	•	•	•	•	—	—	CM	ac Triac, 5m quick-disconnect lead
—	—	—	—	—	—	•	•	SP	(2 BT & 1 KT) 2 Reed, Form C, 5m lead & 1 Hall-effect, Sinking, 5m lead

• = Available — = Not Available

ORDERING

ITEM	ORDERING CODE ¹	PART NUMBER ²
DC REED SWITCHES		
FORM A: 5-meter lead with quick-disconnect coupler	RM	3600-9083 ³
FORM A: 5-meter lead	RT	3600-9082
FORM C: 5-meter lead with quick-disconnect coupler	BM	3600-9085 ³
FORM C: 5-meter lead	BT	3600-9084
HALL-EFFECT SWITCHES		
SINKING: 5-meter lead with quick-disconnect coupler	KM	3600-9091 ³
SINKING: 5-meter lead	KT	3600-9090
SOURCING: 5-meter lead with quick-disconnect coupler	TM	3600-9089 ³
SOURCING: 5-meter lead	TT	3600-9088
AC TRIAC SWITCHES		
5-meter lead with quick-disconnect coupler	CM	3600-9087 ³
5-meter lead	CT	3600-9086
FEMALE CONNECTOR		
5-meter lead	CM	2503-1025



Contact Tol-O-Matic regarding magnet requirements for actuators that did not previously have a switch or if replacing a reed or triac switch with a Hall-effect.

¹ Includes switch and hardware kit

² Switch only

³ Sensor is 6 inches from male coupler on quick-disconnect units

To order field retrofit switch and hardware kits for all Tol-O-Matic actuators, specify 'SW' then the actuator model, bore size and code for switch needed.

EXAMPLE:
SWRSA24RT

(Hardware and form A reed switch with 5-meter lead)

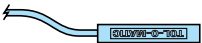

SWITCHES

Kit Availability and Ordering



- **GLOSSARY**
- **CONVERSION TABLES**
- **BASIC SIZING EQUATIONS**
- **ROTARY SIZING EQUATIONS**

Call 1-800-328-2174 for answers to any questions about Axidyne systems and visit tolomatic.com for Tol-O-Motion Sizing & Selection software.

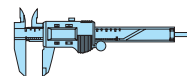

A - D

A

ABSOLUTE MOVE: A move with reference to a fixed absolute zero location.

AC SERVO: Motor/Drive that generates sinusoidal motor currents and sinusoidal back EMF in a brushless motor.

ACCURACY: The degree to which an actuator is able to move to a specific commanded point. On the bullseye below, notice that all the holes are centered around the middle of the target, but the grouping is not very close together. Good accuracy does not require good repeatability. (*see repeatability & accuracy*)

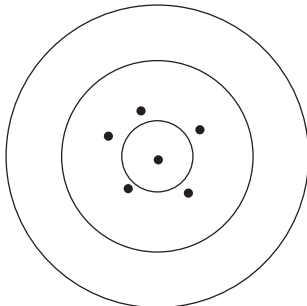

ACME SCREW/NUT: Threaded screw and nut design which utilizes sliding surfaces between the two. Typical efficiencies are between 60-70%.

AUTO-PHASING: The drive function that determines the motor's angular rotor position for commutation without the need for Hall Effect switches.

AXIAL LOADING: Load where the force is acting along the axis of actuator (bearing) in any direction.

B

BACK EMF: Voltage produced across a motor winding due to the winding turns being cut by a magnetic field. This voltage is directly proportional to rotor velocity and is opposite in polarity to the applied voltage.

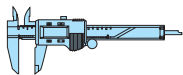

RESOURCES

Glossary

J-2

BACKLASH: Linear distance which is lost in positioning the nut or carrier when the screw direction of rotation changes.

BALL SCREW/NUT: Screw and nut design utilizing a nut that contains one or more circuits of recirculating steel balls which roll between the screw and nut.

BAUD RATE: Number of binary bits transmitted per second in a serial communication system.

BENDING MOMENT: Equivalent torque produced by a force displaced by a known distance from the carriage. Ex. M_x , M_y , M_z , F_z

(*See illustration below*).

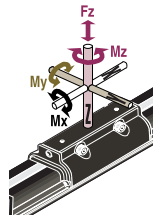

BREAKAWAY TORQUE: Torque required to start an actuator in motion. In an electric actuator, this consists primarily of the torque to overcome the preload of the lead screw nut assembly and the static friction of the carrier bearings.

BRUSHLESS DC SERVO: Motor/drive that generates trapezoidal motor currents and trapezoidal back EMF in a brushless motor.

C

CARRIER: Moving part of a rodless actuator providing a mounting surface for a load.

CLOSED LOOP (FEED BACK): System where the output is measured and compared to the input. If this system is capable of making corrections to minimize the difference it is classified as a servo.

COMMUTATION: Switching of drive voltage to the motor windings necessary to provide continuous rotation. A brush motor uses mechanical switching through a brush-bar contact. Brushless motors use separate devices such as Hall Sensors to sense the rotor position. This information is then processed by the drive to determine the switching sequence.

CONTINUOUS TORQUE: Another term for RMS torque. See RMS torque

CRITICAL SPEED: Rotational speed of a lead screw at which the screw begins to oscillate or whip. This speed is dependent on the screw length and diameter.

CYCLE: A complete motion of actuator's carrier or tooling plate from start to finish and back.

CYCLE RATE: Total number of complete cycles in a specific period of time.

CENTER OF GRAVITY (CENTER OF MASS): The point at which the entire weight of a body may be considered as concentrated so that if supported at this point the body would remain in equilibrium in any position.

D

DEAD LENGTH: Result of subtraction of stroke length from overall length of an actuator.

DEFLECTION: Amount of displacement of a point on rodless actuator carrier or rod actuator tooling plate, under load by forces or bending moments, measured in the direction perpendicular to actuator axis.

D - R

DUTY CYCLE: Ratio of on time to total cycle time.

$$\text{Duty Cycle} = \frac{\text{On Time}}{(\text{On Time} + \text{Off Time})}$$

DWELL TIME: A pause of motion within a move cycle.

E

EFFICIENCY: Ratio of power output to power input.

ENCODER: Device used to provide relative position and velocity information to a drive or controller by sensing mechanical motion and providing a corresponding pulse rate as output.

F

FLATNESS: When traveling in a straight horizontal line, the vertical deviation above or below the horizontal plane of travel of the carrier.

G

GANTRY: A method of connecting two actuators together by a drive shaft so one motor can operate both actuators.

H

HOLDING TORQUE: Maximum external torque that can be applied to a stopped, energized motor without causing the rotor to rotate.

INCREMENTAL MOVE: A positional move referenced from the current position.

INERTIA: Measure of an object's resistance to change in motion that is a function of the object's mass and shape.

INERTIA MATCH: If the reflected inertia of the load is equal to the rotor inertia of the motor, the system will operate optimally for efficiency and dynamic performance.

L

LEAD: Linear travel of a lead screw nut or carriage for every one full rotation of the lead screw expressed in inches per rev.

LOAD: A mass or weight supported by the carrier (rodless cylinders) or tooling plate (rod type cylinders). Ex. Fz (See illustration below).

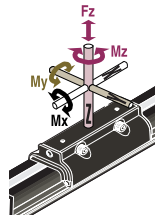

M

MAXIMUM DYNAMIC LOAD:

Load of constant magnitude acting in one direction that results in a nominal life (travel) of a linear motion actuator (component).

MAXIMUM STATIC LOAD:

Maximum load of constant magnitude acting in one direction that a static actuator (component) can withstand without permanent deformation.

MICROSTEPPING: Type of drive that proportions the current in a step motor's windings to provide intermediate positions between full steps. Advantages over full and half stepping include smoothness of rotation and higher position resolution.

MOMENT LOAD: Rotational forces applied to the carrier equal to the linear force applied (weight) multiplied by the distance between the location of the force (center of gravity) and the surface center of the carrier. Typically expressed as yaw (Mz), pitch (Mx) and Roll (My). (See illustration with "LOAD").

MOTION PROFILE: Definition of an object's position and velocity relationships in time during a move.

O

OPEN LOOP: Motion control system where no position or velocity signals are provided for correction. Typically, stepper systems run as open loop systems.

OPTICALLY ISOLATED:

Transmission of a signal from one device to another with a light source (emitted) and sensor (received), in order to avoid direct electrical contact.

P

PITCH: Number of revolutions required by a leadscrew to move the nut or carrier one inch, expressed in revs/per inch

PLC: (Programmable logic controller) A digital electronic device that uses to store instructions and to implement functions such as logic sequencing, timing and counting in order to control machines and processes.

PWM: Pulse Width Modulation is a method of controlling current in the windings of a motor by on-off switching of transistors to vary the duty cycle.

R

RADIAL LOAD: Load where the force is acting perpendicular to the axis of actuator (bearing) in the direction of actuator (bearing).

REGENERATION: Characteristic of a motor to act as a generator when the CEMF (counter electromotive force) is larger than the drive's applied voltage.

REGENERATION BRAKING: The technique of slowing or stopping a drive by regeneration.

REPEATABILITY: The degree to which an actuator can return to a reference location. Notice on the bullseye on the next page that the holes are close together, however the

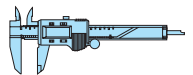

RESOURCES

Glossary

R - Z

grouping is far from the bullseye. Repeatability can be thought of as how tight a grouping can be made. Unidirectional repeatability, measured by approaching a position from a single direction, hides errors caused by backlash and hysteresis effects. Bidirectional repeatability, measured by approaching a position from opposing directions, includes these effects, and provides a more meaningful specification.

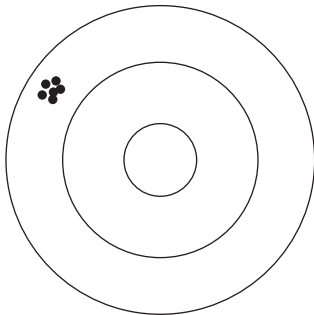

REPEATABILITY & ACCURACY:

The measure of how close to a programmed point the actuator can come, and how close it gets to that same point again. The repeatability of industrial actuators is usually much better than the accuracy. Notice on the bullseye below that the points are centered around the middle of the target and are grouped close together. This is good accuracy and repeatability.

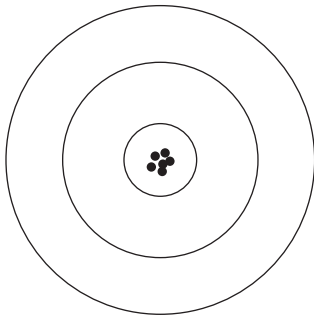

RESOLUTION: The smallest position increment that can be achieved.

RESOLVER: A feedback device consisting of a stator and rotor that provides position and velocity information to the drive for

commutation.

REVERSE RADIAL LOAD: Load where the force is acting perpendicular to the axis of actuator (bearing) in the direction opposite from actuator (bearing).

RMS TORQUE: In an intermittent application, this is the torque provided to generate equivalent motor heating to one operating in a steady state.

$$T_{rms} = \sqrt{\frac{\sum(T_i^2 \cdot t_i)}{\sum t_i}}$$

where: T_i = Torque during interval i
 t_i = Time of interval i

RS232: A standard for data communication that defines voltages and time requirements for information to be transferred on a single line in sequential format.

S

SERVO: System that compares the output of a device (by monitoring position, velocity, and/or torque) with the desired outcome and makes corrections to minimize the difference.

SERVO MOTOR: Motor used in closed loop systems where feedback is used to control motor position, velocity, and/or torque, usually expected to have high torque/inertia ratio.

SLEW: Constant non-zero velocity portion of a motion profile.

STALL TORQUE: Maximum torque available at zero speed.

STEPPER MOTOR: Motor which translates electrical pulses into motion, where the pulse rate controls velocity and position.

STIFFNESS: System ability to maintain accuracy when subject to disturbance.

STRAIGHTNESS: When traveling in a straight horizontal line, the side to

side deviation within the horizontal plane of travel of the carrier.

STROKE LENGTH: The distance that the carrier and its load will move on the actuator.

T

THRUST: Measurement of linear force.

TORQUE: Measurement of force producing rotation.

TORQUE CONSTANT: Torque generated in a DC motor per ampere applied to the windings.

$$K_t = \frac{T \text{ (oz.-in.)}}{A \text{ (amp)}}$$

VOLTAGE CONSTANT: Back EMF generated by a DC motor usually in units of volts per 1000 rpm.

$$K_e = \frac{\text{volts}}{1000 \text{ rpm}}$$

TRAPEZOIDAL PROFILE: a velocity vs time profile that is characterized by total move time split evenly for acceleration, deceleration and velocity.

TRIANGULAR PROFILE: a velocity vs time profile that is characterized by equal time for acceleration and deceleration.

VECTOR DRIVE: A class of drives that sense motor current in each individual motor phase and resolves these readings into two current vectors. One vector is the torque producing current and other is the waste current. The current control algorithm then works to drive the non-torque-producing component to zero. This result in a high bandwidth torque response over the full speed range without the phase lag and tolerance issues that place older drive technologies.

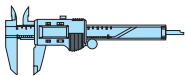

RESOURCES

Glossary

Axi-dyne® Conversion Tables

To convert from A to B, multiply by the entry in table

LENGTH

A \ B	in	ft	yd	mm	cm	m
in	1.0	0.0833	0.028	25.4	2.54	0.0254
ft	12.0	1.0	0.333	304.8	30.48	0.3048
yd	36.0	3.0	1.0	914.4	91.44	0.914
mm	0.03937	0.00328	1.09×10^{-3}	1.0	0.1	0.001
cm	0.3937	0.03281	1.09×10^{-2}	10.0	1.0	0.01
m	39.37	3.281	1.09	1000.0	100.0	1.0

FORCE

A \ B	lb(f)	N	dyne	oz(f)	kg(f)	gm(f)
lb(f)	1.0	4.4482	4.448×10^5	16.0	0.45359	453.6
N	0.22481	1.0	100.000	3.5967	0.10197	---
dyne	2.248×10^{-6}	0.00001	1.0	3.59×10^{-5}	---	980.6
oz(f)	0.0625	0.27801	2.78×10^4	1.0	0.02835	28.35
kg(f)	2.205	9.80665	---	35.274	1.0	1000.0
gm(f)	2.205×10^{-3}	---	1.02×10^{-3}	0.03527	0.001	1.0

NOTE: lb(f) = 1 slug x 1 ft/s² N = 1 kg x 1 m/s² dyne = 1 gm x 1 cm/s²

INERTIA (ROTARY)

NOTE: Mass inertia = $\frac{wt. \text{ inertia}}{g}$

A \ B	gm-cm ²	oz-in ²	gm-cm-s ²	kg-cm ²	lb-in ²	oz-in-s ²	lb-ft ²	kg-cm-s ²	lb-in-s ²	lb-ft-s ² or slug-ft-s ²
gm-cm ²	1.0	5.46×10^{-2}	1.01×10^{-3}	10^{-3}	3.417×10^{-4}	1.41×10^{-5}	2.37×10^{-6}	1.01×10^{-4}	8.85×10^{-7}	7.37×10^{-4}
oz-in ²	182.9	1.0	.186	0.182	0.0625	2.59×10^{-3}	4.34×10^{-4}	1.86×10^{-4}	1.61×10^{-4}	1.34×10^{-5}
gm-cm-s ²	980.6	5.36	1.0	0.9806	0.335	1.38×10^{-2}	2.32×10^{-3}	10^3	8.67×10^{-4}	7.23×10^{-5}
kg-cm ²	1000.0	5.46	1.019	1.0	0.3417	1.41×10^{-2}	2.37×10^{-3}	1.019×10^{-3}	8.85×10^{-4}	7.37×10^{-5}
lb-in ²	2.92×10^3	16.0	2.984	2.925	1.0	4.14×10^{-2}	6.94×10^{-3}	2.96×10^{-3}	2.59×10^{-3}	2.15×10^{-4}
oz-in-s ²	7.06×10^4	386.0	72.0	70.615	24.13	1.0	0.1675	7.20×10^{-2}	6.25×10^{-2}	5.20×10^{-3}
lb-ft ²	4.21×10^5	2304.0	429.71	421.40	144.0	5.967	1.0	0.4297	0.3729	3.10×10^{-2}
kg-cm-s ²	9.8×10^5	5.36×10^3	1000.0	980.66	335.1	13.887	2.327	1.0	0.8679	7.23×10^{-2}
lb-in-s ²	1.129×10^4	6.177×10^3	1.152×10^3	1.129×10^3	386.08	16.0	2.681	1.152	1.0	8.33×10^{-2}
lb-ft-s ²	1.355×10^7	7.41×10^4	1.38×10^4	1.35×10^4	4.63×10^3	192.0	32.17	13.825	12.0	1.0

TORQUE

A \ B	dyne-cm	gm-cm	oz-in	kg-cm	lb-in	N-m	lb/ft	kg/m
dyne-cm	1.0	1.019×10^{-3}	1.416×10^{-5}	1.0197×10^{-6}	8.850×10^{-7}	10^{-7}	7.375×10^{-6}	1.019×10^{-6}
gm-cm	980.665	1.0	1.388×10^{-2}	10^3	8.679×10^{-4}	9.806×10^{-3}	7.233×10^{-5}	10^5
oz-in	7.061×10^4	72.007	1.0	7.200×10^{-2}	6.25×10^{-2}	7.061×10^{-3}	5.208×10^{-3}	7.200×10^{-4}
kg-cm	9.806×10^5	1000.0	13.877	1.0	0.8679	9.806×10^{-2}	7.233×10^{-2}	10^2
lb-in	1.129×10^6	1.152×10^3	16.0	1.152	1.0	0.112	8.333×10^{-2}	1.152×10^{-2}
N-m	10^7	1.019×10^4	141.612	10.197	8.850	1.0	0.737	0.102
lb-ft	1.355×10^7	1.382×10^4	192.0	13.825	12.0	1.355	1.0	0.138
kg-m	9.806×10^7	10^5	1.388×10^3	100.0	86.796	9.806	7.233	1.0

ANGULAR VELOCITY

A \ B	deg/s	rad/s	rpm	rps
deg/s	1.0	1.75×10^{-2}	0.167	2.78×10^{-3}
rad/s	57.3	1.0	9.55	0.159
rpm	6.0	0.105	1.0	1.67×10^{-2}
rps	360.0	6.28	60.0	1.0

ABBREVIATED TERMS

C = Celsius	gm(f) = gram force	lb(f) = pound force	oz(f) = ounce force
cm = centimeter	hp = horse power	lb(m) = pound mass	oz(m) = ounce mass
F = Fahrenheit	in = inch	min = minute	rad = radians
ft = foot	kg = kilogram	mm = millimeter	rpm = revs per minute
g = gravity	kg(f) = kilogram force	m = meter	rps = revs per second
gm = gram	kw = Kilowatt	N = Newton	s = seconds

MASS

A \ B	gm	kg	slug	lb(m)	oz(m)
gm	1.0	0.001	6.852×10^{-5}	2.205×10^{-3}	0.03527
kg	1000.0	1.0	6.852×10^{-2}	2.205	35.274
slug	14590.0	14.59	1.0	32.2	514.72
lb(m)	453.6	0.45359	0.0311	1.0	16.0
oz(m)	28.35	0.02835	1.94×10^{-3}	0.0625	1.0

POWER

A \ B	Watts	KW	HP (English)	HP (Metric)	ft-lb/s	in-lb/s
Watts	1.0	1×10^{-3}	1.34×10^{-3}	1.36×10^{-3}	0.74	8.88
kw	1000.0	1.0	1.34	1.36	738.0	8880.0
hp(English)	746.0	0.746	1.0	1.01	550.0	6600.0
hp(Metric)	736.0	.0736	0.986	1.0	543.0	6516.0
ft-lb/s	1.35	1.36×10^{-3}	1.82×10^{-3}	1.84×10^{-3}	1.0	12.0
in-lb/s	0.113	1.13×10^{-4}	1.52×10^{-4}	1.53×10^{-4}	8.3×10^{-2}	1.0

TEMPERATURE

$^{\circ}\text{F} = (1.8 \times ^{\circ}\text{C}) + 32$
$^{\circ}\text{C} = .555 (^{\circ}\text{F} - 32)$

GRAVITY

(Acceleration Constant)
$g = 386 \text{ in/s}^2 = 32.2 \text{ ft/s}^2 = 9.8 \text{ m/s}^2$

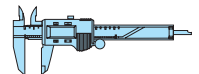

RESOURCES

Conversion Tables

Axi dyne® Basic Sizing Equations

MOTION PROFILES

MOTION PROFILE INTRODUCTION

Move Profile

Actuator selection begins with the calculation of speed requirements. A move profile is a plot of velocity vs. time for a machine cycle.

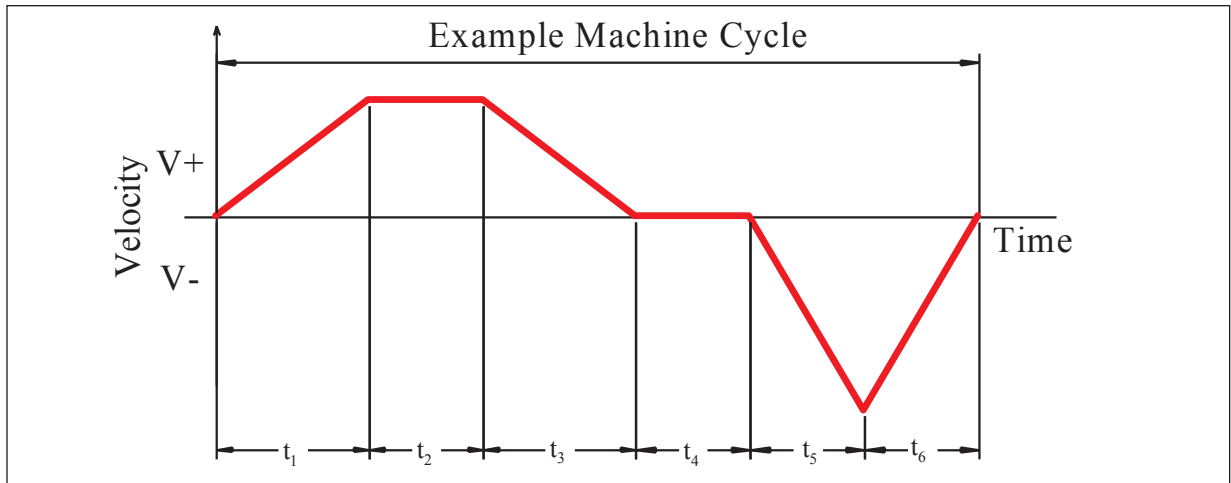

The Figure above shows a typical machine cycle. The first move is a trapezoidal move profile and the second is a triangular profile. During the trapezoidal move the load accelerates for a time (t_1), has a constant speed for time (t_2) and decelerates to a stop in time (t_3). After a dwell time (t_4) the load reverses direction and accelerates for time (t_5) and then decelerates back to a stop in time (t_6).

Trapezoidal and Triangular Profiles

Each actuator will have a maximum speed that it can achieve for each specific load capacity. This maximum speed will determine which type of motion profile can be used to complete the move. Two common types move profiles are trapezoidal and triangular.

If the average velocity of the profile, is less than half the maximum velocity of the actuator, then triangular profiles can be used. Triangular profiles result in the lowest possible acceleration and deceleration. Otherwise a trapezoidal profile with 3 equal divisions will result in 25% lower maximum speed and 12.5% higher acceleration and deceleration. This is commonly called a 1/3 trapezoidal profile. The trapezoidal move profile provides a good compromise between acceleration rate and max speed and is the recommended move profile.

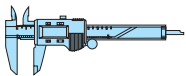
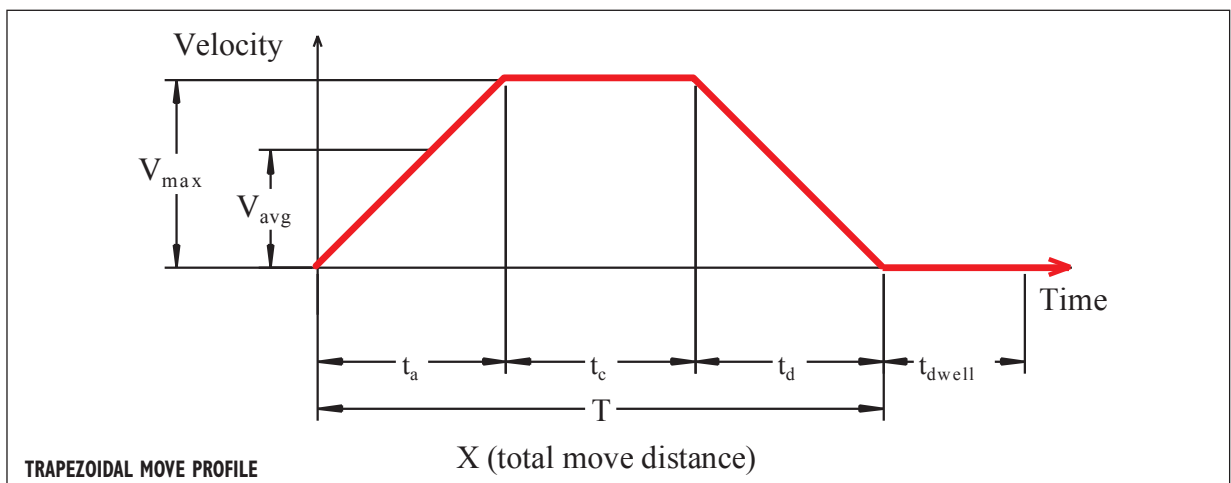

RESOURCES

Sizing Equations
• Motion profiles

Axi-dyne® Basic Sizing Equations

MOTION PROFILES

FOR GREATER SPEED AND ACCURACY USE TOL-O-MOTION SIZING & SELECTION SOFTWARE AVAILABLE AT WWW.TOLOMATIC.COM

TRIANGULAR PROFILE

$$\text{Assume : } t_a = t_c = t_d = \frac{T}{3}$$

$$\text{Then : } V_{\max} = \frac{1.5 \cdot X}{T}$$

$$a = d = \frac{4.5 \cdot X}{T^2}$$

$$V_{\text{avg}} = \frac{X}{T}$$

X = total move distance
 T = total move time
 a = acceleration rate
 d = deceleration rate
 t_a = acceleration time
 t_c = constant speed time
 t_d = deceleration time
 t_{dwell} = dwell time
 V_{\max} = maximum velocity
 V_{avg} = average velocity

TRAPEZOIDAL EQUATIONS

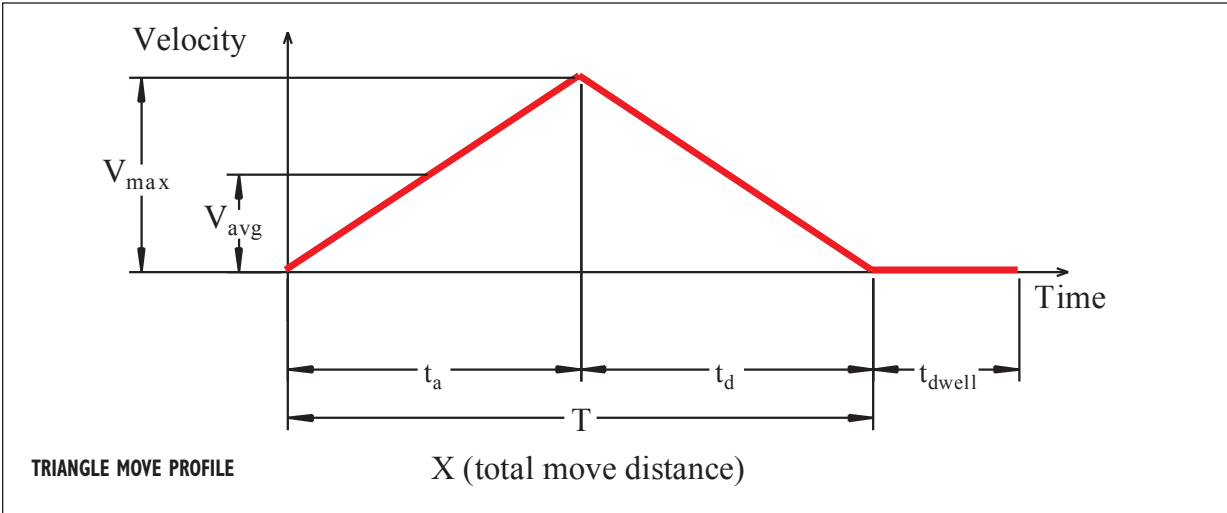

$$V_{\max} = 2 \cdot V_{\text{avg}} = 2 \frac{X}{T}$$

$$t_a = t_d = \frac{T}{2}$$

$$a = d = \frac{2 \cdot V_{\max}}{T} = \frac{4 \cdot X}{T^2}$$

TRIANGULAR EQUATIONS

X = total move distance
 T = total move time
 a = acceleration rate
 d = deceleration rate
 t_a = acceleration time
 t_d = deceleration time
 t_{dwell} = dwell time
 V_{\max} = maximum velocity
 V_{avg} = average velocity

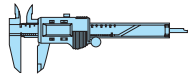

RESOURCES

Sizing Equations
 • Motion profiles

Axi *dyne*® Basic Sizing Equations

MOTION PROFILES

TRAPEZOIDAL MOTION PROFILE

Motion parameter calculations for a Trapezoidal motion profile

X = Total move distance..... = _____ (in.)

T = Total move time..... = _____ (sec.)

t_{dwell} = Dwell time after the motion..... = _____ (sec.)

Trapezoidal move profile *(Enter your application values designated in light blue.)*

Calculate the maximum velocity of the move

$$V_{\max} = 1.5 \cdot \frac{X}{T} = 1.5 \cdot \left[\frac{X}{T} \right] \dots\dots\dots = \text{_____ (in./sec.)}$$

Calculate the maximum acceleration rate of the move

$$a = \frac{4.5 \cdot X}{T^2} = \frac{4.5 \cdot \left[X \right]}{\left[T^2 \right]} \dots\dots\dots = \text{_____ (in./sec.^2)}$$

Calculate the acceleration time for the move

$$t_a = \frac{T}{3} = \left[\frac{T}{3} \right] \dots\dots\dots = \text{_____ (sec.)}$$

Calculate the constant speed time for the move

$$t_d = \frac{T}{3} = \left[\frac{T}{3} \right] \dots\dots\dots = \text{_____ (sec.)}$$

Calculate the deceleration time for the move

$$t_d = \frac{T}{3} = \left[\frac{T}{3} \right] \dots\dots\dots = \text{_____ (sec.)}$$

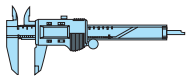

RESOURCES

Sizing Equations
• Motion profiles

Axi-dyne® Basic Sizing Equations

MOTION PROFILES

FOR GREATER SPEED AND ACCURACY USE TOL-O-MOTION SIZING & SELECTION SOFTWARE AVAILABLE AT WWW.TOLOMATIC.COM

EXAMPLE

An actuator needs to move 12 inches in 2 seconds, then wait for 1 sec. Using a trapezoidal profile, calculate the acceleration/deceleration rate, move time for each segment and maximum velocity.

X = Total move distance..... = 12 inches
 T = Total move time..... = 2 sec
 t_{dwell} = Dwell time after the motion..... = 1 sec

Trapezoidal move profile

Calculate the maximum velocity of the move

$$V_{max} = 1.5 \cdot \frac{X}{T} = 1.5 \cdot \frac{[12]}{[2]} = 9 \frac{in}{sec}$$

Calculate the maximum acceleration rate of the move

$$a = \frac{4.5 \cdot X}{T^2} = \frac{4.5 \cdot [12]}{[2^2]} = 13.5 \frac{in}{sec^2}$$

Calculate the acceleration time for the move

$$t_a = \frac{T}{3} = \frac{[2]}{3} = 0.667 sec$$

Calculate the constant speed time for the move

$$t_d = \frac{T}{3} = \frac{[2]}{3} = 0.667 sec$$

Calculate the deceleration time for the move

$$t_d = \frac{T}{3} = \frac{[2]}{3} = 0.667 sec$$

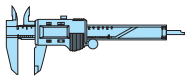

RESOURCES

Sizing Equations
 • Motion profiles

Axi dyne® Basic Sizing Equations

RODLESS ACTUATOR SIZING

INTRODUCTION

Rodless actuators have bearings that are designed to support loads, however actuator loading is limited, and moment, normal, and side loads on the rodless actuator need to be evaluated. Moment loads are rotational forces (or torque) which are applied to the carriage assembly. They are defined by the axis they are acting upon.

Note: *This manual sizing example only applies to horizontal applications with a single carrier supporting 100% of the load weight. For other orientations or dual carrier systems it is recommended that the sizing and selection software be used.*

To evaluate the actuator forces use the diagram below. The three forces (F_x , F_y , F_z) and the load weight (W) are a general loading condition and applies to the load a distance (x,y,z) from the center point of the carrier. These forces may be due to gravity, friction, applied loads and the actuator thrust. Each of these forces may act at different points of application. For example, gravity will act at the center of gravity of the load, while friction and applied loads will act at the edge of the load.

The equations for moment loads assume that the directions of the arrows in the figure are positive. If the forces or torques in your application work in the opposite direction, they are negative and they should be entered as negative numbers.

The thrust required to move a load a given distance in a given time may be calculated by summing all of the forces that act on the load. These forces fall within the following four types:

GRAVITY is an important factor when the load is being raised or lowered. When the application is moving horizontal the gravity force is zero.

FRICTION FORCE is present from the friction in the guide rod bearings. This force will vary depending on the type of bearing used.

EXTERNAL FORCE can come from springs, other actuators, magnets, and are the forces that act in the direction of travel other than bearing friction.

ACCELERATION/DECELERATION FORCE is the force that the actuator needs to produce to get the load to the required speed and slow it back down.

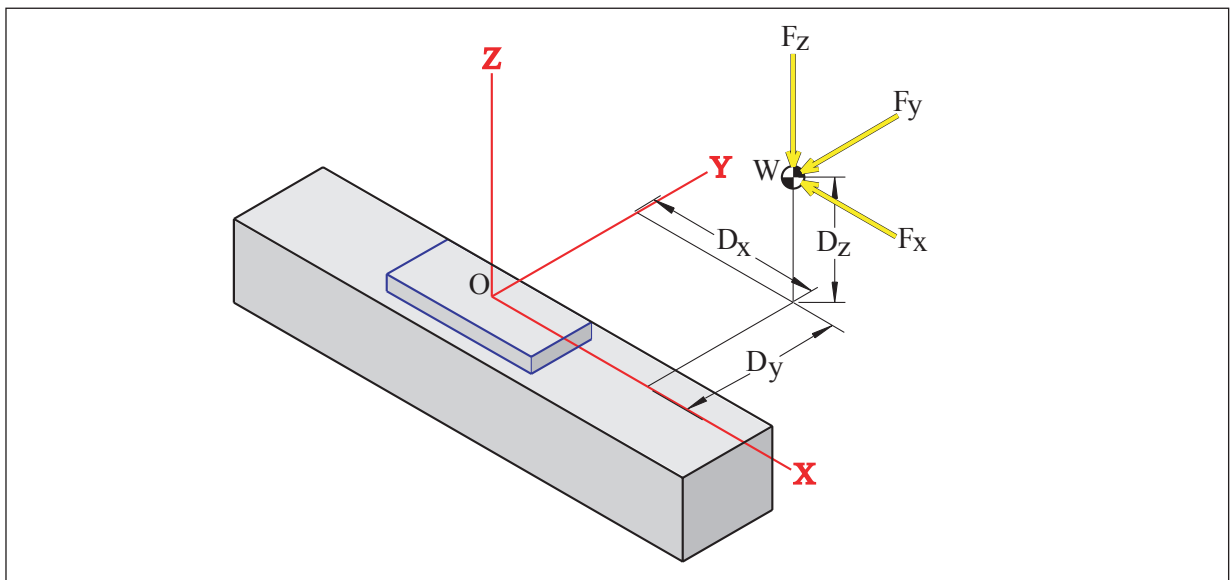

The figure above shows a top view general case where the force required by the actuator must be determined. All the forces are included, and it is important to note that all of these forces can change over time, so the actuator force must be calculated for each section of the move profile. The worst case thrust, speed and tooling plate deflection required should be used to pick the appropriate actuator.

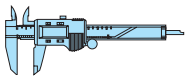

RESOURCES

Sizing Equations
• Rodless actuators

J-10

Axi dyne® Basic Sizing Equations

RODLESS ACTUATOR SIZING

REQUIRED INFORMATION, CALCULATIONS

Required information

- W = Weight of object being moved..... = _____ (lbs.)
 a = Maximum acceleration rate from motion profile..... = _____ (in./sec.²)
 g = Gravity constant..... = $386 \frac{\text{in}}{\text{sec}^2}$
 D_x = Distance from center of carrier to center of gravity of load along X axis = _____ (in.)
 D_y = Distance from center of carrier to center of gravity of load along Y axis = _____ (in.)
 D_z = Distance from center of carrier to center of gravity of load along Z axis = _____ (in.)
 F_{ext_x} = External force on load along the X axis..... = _____ (lbs.)
 F_{ext_y} = External force on load along the Y axis..... = _____ (lbs.)
 F_{ext_z} = External force on load along the Z axis..... = _____ (lbs.)

Calculations (Enter your application values designated in light blue.)

Force in the X axis

$$F_x = F_{\text{ext}_x} + \frac{W}{g} \cdot a = [F_{\text{ext}_x}] + \left[\frac{W}{g} \right] \cdot [a] \dots\dots\dots = \text{_____ (lbs.)}$$

Force in the Y axis

$$F_y = F_{\text{ext}_y} = \dots\dots\dots = \text{_____ (lbs.)}$$

Force in the Z axis

$$F_z = F_{\text{ext}_z} + W = [F_{\text{ext}_z}] + [W] \dots\dots\dots = \text{_____ (lbs.)}$$

Moment load about the X axis

$$M_x = F_z \cdot D_y - F_y \cdot D_z = [F_z] \cdot [D_y] - [F_y] \cdot [D_z] \dots\dots\dots = \text{_____ (lbs.-in.)}$$

Moment load about the Y axis

$$M_y = F_z \cdot D_x - F_x \cdot D_z = [F_z] \cdot [D_x] - [F_x] \cdot [D_z] \dots\dots\dots = \text{_____ (lbs.-in.)}$$

Moment load about the Z axis

$$M_z = F_y \cdot D_x - F_x \cdot D_y = [F_y] \cdot [D_x] - [F_x] \cdot [D_y] \dots\dots\dots = \text{_____ (lbs.-in.)}$$

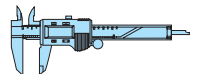

RESOURCES

Sizing Equations
• Rodless actuators

Axi dyne® Basic Sizing Equations

RODLESS ACTUATOR SIZING

SELECTING THE CORRECT ACTUATOR

Pick an actuator that has the thrust, speed, and moment load capability to move the load. Use the speed/stroke graph for the screw, and the specification tables for the actuator families shown in Section C. Keep in mind the following information during the selection process:

Screw Critical Speed and Thrust limit

When using the critical speed charts, the intersection on the graph of the application speed and the actuator stroke length must lie below the curve for the screw being considered. Each screw also has a thrust limit and the F_x force must be below this limit.

Moment Loads

Application moment loads calculated for the X, Y and Z axis must be less than the values shown in the Section C tables for the actuator being considered.

Forces

Application forces calculated for the Y and Z axis must be less than the values shown in the Section C tables for the actuator being considered.

Loading Combination Factor

The actuator is not designed to have the full rated load on all axis at the same time. The loading combination factor (see below) is used to determine if the combination of all the forces is excessive for the actuator chosen.

Required information *(Enter your application values designated in light blue.)*

F_x = Force in the X axis..... = _____ (lbs.)
 F_y = Force in the Y axis..... = _____ (lbs.)
 F_z = Force in the Z axis..... = _____ (lbs.)
 M_x = Moment load about the X axis..... = _____ (lbs.-in.)
 M_y = Moment load about the Y axis..... = _____ (lbs.-in.)
 M_z = Moment load about the Z axis..... = _____ (lbs.-in.)

$$C_f = \frac{M_x}{M_{x_max}} + \frac{M_y}{M_{y_max}} + \frac{M_z}{M_{z_max}} + \frac{F_y}{F_{y_max}} + \frac{F_z}{F_{z_max}}$$

$$C_f = \left[\frac{M_x}{M_{x_max}} \right] + \left[\frac{M_y}{M_{y_max}} \right] + \left[\frac{M_z}{M_{z_max}} \right] + \left[\frac{F_y}{F_{y_max}} \right] + \left[\frac{F_z}{F_{z_max}} \right] \dots = \underline{\hspace{2cm}}$$

The moment combination factor must be less than or equal to 1.5

If it is greater than 1.5 a larger actuator should be chosen.

$$C_f \leq 1.5$$

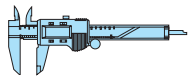

RESOURCES

Sizing Equations
• Rodless actuators

Axi dyne® Basic Sizing Equations

ROD SCREW ACTUATOR SIZING

INTRODUCTION

Rod style actuators are used when the load being moved is guided by an external device. In the following example the load is being pushed up an incline. The actuator does not need to support the weight of the load just provide thrust to push it up the incline.

The thrust required to move a load a given distance in a given time may be calculated by summing all of the forces that act on the load. These forces fall within the following four types:

GRAVITY is an important factor when the load is being raised or lowered. When the application is moving horizontal the gravity force is zero.

FRICTION FORCE is present when moving the load using external supports. An example would be pushing a box across a conveyor belt or when using an external bearing support.

EXTERNAL FORCE can come from springs, other actuators, magnets, and are the forces that act in the direction of travel on the load other than friction and gravity.

ACCELERATION/DECELERATION FORCE is the force that the actuator needs to produce to get the load to the required speed and slow it back down. By convention when accelerating the force is positive and when decelerating the force is negative.

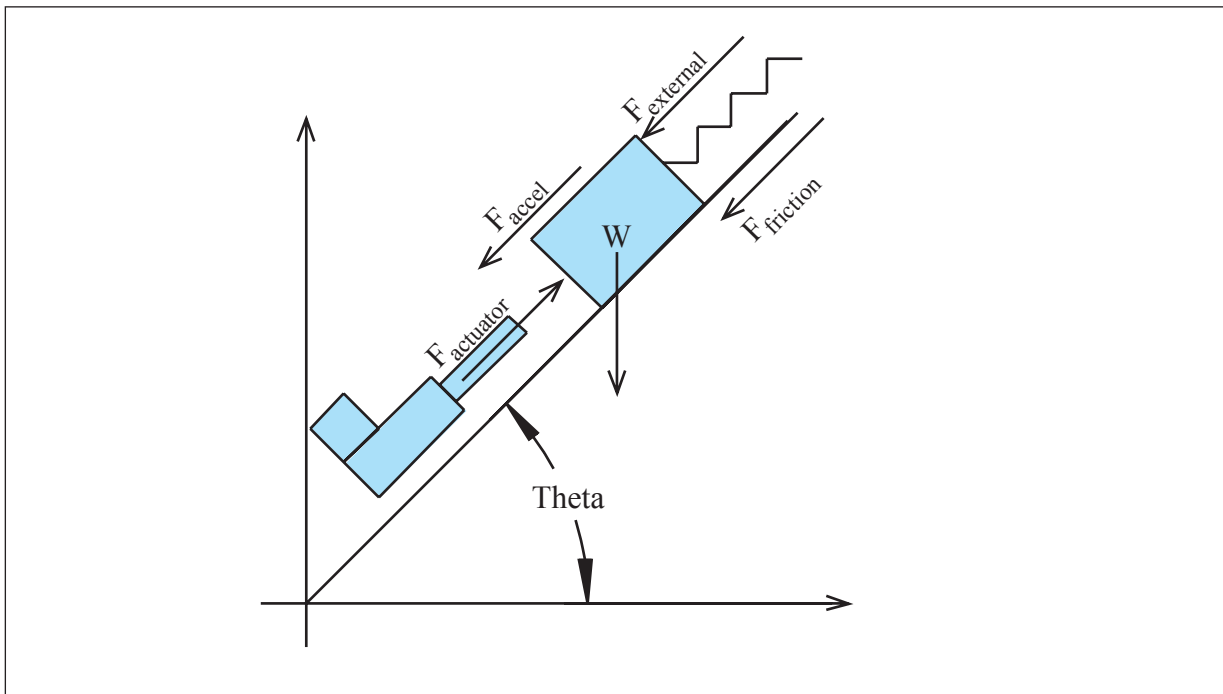

The figure above shows a general case where the force required by the actuator must be determined. All the forces are included, and it is important to note that all of these forces can change over time, so the actuator force must be calculated for each section of the move profile. The worst case thrust and speed required should be used to pick the appropriate actuator.

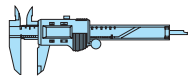

RESOURCES

Sizing Equations
• Rod screw actuators

Axi dyne® Basic Sizing Equations

ROD SCREW ACTUATOR SIZING

REQUIRED INFORMATION, CALCULATIONS

Required information

W_{load} = Weight of object being moved = _____ (lbs.)
 W_b = Base weight of moving parts = _____ (lbs.)
 W_{stroke} = Weight of moving parts per inch of stroke..... = _____ (lbs./in.)
 W = Total weight = $W_{load} + W_b + W_{stroke} \cdot stroke$ = _____ (lbs.)
 a = Acceleration rate from the motion profile..... = _____ (in./sec.²)
 g = Gravity constant..... = $386 \frac{\text{in}}{\text{sec}^2}$
 μ = Coefficient of friction for selected bearing type..... = _____
 θ = Angle of the actuator from horizontal..... = _____ °
 $F_{external}$ = External force acting in the direction of travel..... = _____ (lbs.)

Calculations (Enter your application values designated in light blue.)

Force to accelerate load

$$F_{accel} = \frac{W}{g} \cdot a = \left[\frac{W}{g} \right] \cdot \left[a \right] \dots\dots\dots = \text{_____ (lbs.)}$$

Force from friction

$$F_{friction} = \mu \cdot W \cdot \cos(\theta) = \left[\mu \right] \cdot \left[W \right] \cdot \cos \left[\theta \right] \dots\dots\dots = \text{_____ (lbs.)}$$

Force due to gravity

$$F_{gravity} = W \cdot \sin(\theta) = \left[W \right] \cdot \left[\theta \right] \dots\dots\dots = \text{_____ (lbs.)}$$

Force during acceleration segment

$$F_a = F_{gravity} + F_{friction} + F_{external} + F_{accel} = \left[F_{gravity} \right] + \left[F_{friction} \right] + \left[F_{external} \right] + \left[F_{accel} \right] = \text{_____ (lbs.)}$$

Force during constant speed segment

$$F_c = F_{gravity} + F_{friction} + F_{external} = \left[F_{gravity} \right] + \left[F_{friction} \right] + \left[F_{external} \right] \dots\dots\dots = \text{_____ (lbs.)}$$

Force during deceleration segment

$$F_d = F_{gravity} + F_{friction} + F_{external} - F_{accel} = \left[F_{gravity} \right] + \left[F_{friction} \right] + \left[F_{external} \right] - \left[F_{accel} \right] = \text{_____ (lbs.)}$$

Force during the dwell segment (zero is value is negative)

$$F_{dwell} = F_{gravity} - F_{friction} + F_{external} = \left[F_{gravity} \right] - \left[F_{friction} \right] + \left[F_{external} \right] \dots\dots\dots = \text{_____ (lbs.)}$$

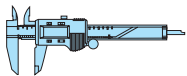

RESOURCES

Sizing Equations
• Rod screw actuators

Axi*dyne*[®] Basic Sizing Equations

ROD SCREW ACTUATOR SIZING

SELECTING THE CORRECT ACTUATOR

Pick an actuator that has the thrust, speed and stroke capability to move the load. Use the graphs in this catalog to determine the speed/stroke length and the maximum screw thrust for the actuators shown in Section D. Keep in mind the following information during the selection process:

Screw Critical Speed and Thrust limit

When using the critical speed charts, the intersection on the graph of the application speed and the actuator stroke length must lie below the curve for the screw being considered. Each screw also has a thrust limit and the maximum thrust from the motion segments must be below this limit.

The options when selecting an actuator are:

1. Body size – 6 body sizes available.
2. Inline or reverse parallel motor mounting
Effects the mounting options and motor sizes possible (see actuator options in Section D).

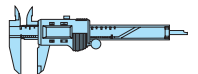

RESOURCES

Sizing Equations
• Rod screw actuators

Axi dyne® Basic Sizing Equations

GUIDED SCREW ACTUATOR SIZING

INTRODUCTION

Guided Screw Actuators (GSA) are used when the load being moved needs to be supported and guided. The actuator will support the weight of the load as it is moved along the actuator stroke.

Note: *This manual sizing example only applies to horizontal applications with the tooling plate in the horizontal orientation. For other orientations it is recommended that the sizing and selection be used.*

The thrust required to move a load a given distance in a given time may be calculated by summing all of the forces that act on the load. These forces fall within the following four types:

GRAVITY is an important factor when the load is being raised or lowered. When the application is moving horizontal the gravity force is zero.

FRICTION FORCE is present from the friction in the guide rod bearings. This force will vary depending on the type of bearing used.

EXTERNAL FORCE can come from springs, other actuators, magnets, and are the forces that act in the direction of travel other than bearing friction.

ACCELERATION/DECELERATION FORCE is the force that the actuator needs to produce to get the load to the required speed and slow it back down.

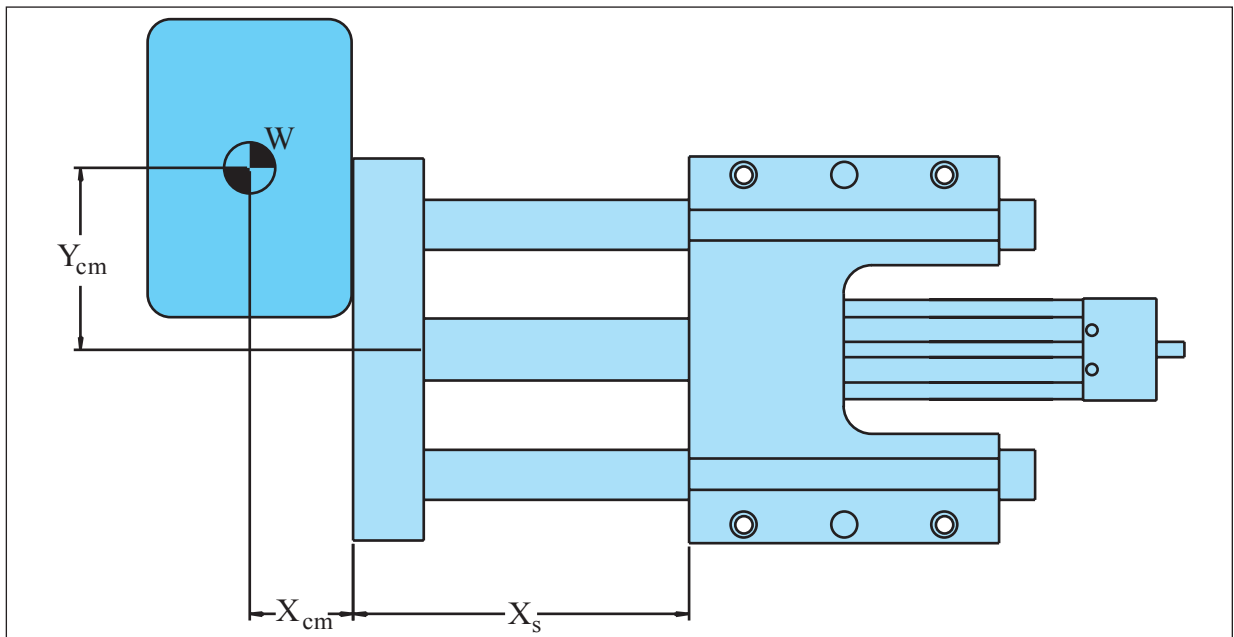

The figure above shows a top view general case where the force required by the actuator must be determined. All the forces are included, and it is important to note that all of these forces can change over time, so the actuator force must be calculated for each section of the move profile. The worst case thrust, speed and tooling plate deflection required should be used to pick the appropriate actuator.

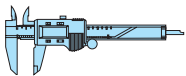

RESOURCES

Sizing Equations
• Guided screw actuators

REQUIRED INFORMATION, CALCULATIONS

Required information

- W_{load} = Weight of object being moved = _____ (lbs.)
 W_b = Base weight of moving parts = _____ (lbs.)
 W_{stroke} = Weight of moving parts per inch of stroke..... = _____ (lbs./in.)
 W = Total weight = $W_{load} + W_b + W_{stroke} \cdot stroke$ = _____ (lbs.)
 a = Acceleration rate from motion profile..... = _____ (in./sec.²)
 g = Gravity constant..... = $386 \frac{\text{in}}{\text{sec}^2}$
 μ = Coefficient of friction for selected bearing type..... = _____
 X_s = Stroke length of the actuator..... = _____ (in.)
 X_{CM} = Distance from the tooling plate to the load's center of mass..... = _____ (in.)
 Y_{CM} = Distance from the center of tooling plate the the load's center of mass... = _____ (in.)
 $F_{external}$ = External force on load..... = _____ (lbs.)

Calculations (Enter your application values designated in light blue.)

Force to accelerate load

$$F_{accel} = \frac{W}{g} \cdot a = \left[\frac{W}{g} \right] \cdot \left[a \right] \dots\dots\dots = \text{_____ (lbs.)}$$

Force from guide bearing friction

$$F_{friction} = \mu \cdot W = \left[\mu \right] \cdot \left[W \right] \dots\dots\dots = \text{_____ (lbs.)}$$

Force during acceleration segment

$$F_a = F_{friction} + F_{external} + F_{accel} = \left[F_{friction} \right] + \left[F_{external} \right] + \left[F_{accel} \right] \dots\dots\dots = \text{_____ (lbs.)}$$

Force during constant speed segment

$$F_c = F_{friction} + F_{external} = \left[F_{friction} \right] + \left[F_{external} \right] \dots\dots\dots = \text{_____ (lbs.)}$$

Force during deceleration segment

$$F_d = F_{friction} + F_{external} - F_{accel} = \left[F_{friction} \right] + \left[F_{external} \right] - \left[F_{accel} \right] \dots\dots\dots = \text{_____ (lbs.)}$$

Adjusted stroke length

$$X_{adj} = X_s + X_{CM} = \left[X_s \right] + \left[X_{CM} \right] \dots\dots\dots = \text{_____ (lbs.)}$$

Weight adjusted for an off center load

$$W_{adj} = W \cdot (1 + 0.48 \cdot Y_{CM}) = \left[W \right] \cdot (1 + 0.48 \cdot \left[Y_{CM} \right]) \dots\dots\dots = \text{_____ (lbs.)}$$

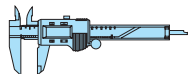

RESOURCES

- Sizing Equations**
 • Guided screw actuators

Axi dyne® Basic Sizing Equations

GUIDED SCREW ACTUATOR SIZING

SELECTING THE CORRECT ACTUATOR

Pick an actuator that has the thrust, speed, and guide rod deflection capability to move the load. There are three graphs in Section E of this catalog, thrust/speed for the screw, load weight/stroke for bearing and guide rod deflection/stroke length. All three graphs must be used to select an actuator. Keep in mind the following information during the selection process:

Screw Critical Speed and Thrust limit

When using the critical speed charts, the intersection on the graph of the application speed and the actuator stroke length must lie below the curve for the screw being considered. Each screw also has a thrust limit and the maximum thrust from the motion segments must be below this limit.

Guide Bearing Capacity

When using the load weight/stroke charts, the intersection point of adjusted stroke length and load weight values should always lie under the curve in order to obtain a nominal bearing life. If composite bearings are selected, linear speed must be taken into consideration.

Guide Rod Deflection

When using the deflection charts, the intersection point of adjusted stroke length and load weight values should always lie under the curve for the desired amount of guide rod deflection when actuator is fully extended. The recommended maximum for guide rod deflection is 0.064 inches.

The options when selecting an actuator are:

1. Body size – 4 body sizes available.
2. Guide Rod
 - Standard
 - Oversize – Reduces the deflection of tooling plate (only available with composite bearings).
 - Stainless Steel Standard Sized – Used when environments require.
 - Stainless Steel Oversized - Used when environments require reducing the deflection of tooling plate.
3. Bearing type
 - Linear ball – Used for long life in clean environments, only available with standard guide rods
 - Composite – Used in dirty environments and where stainless steel guide rods are required.

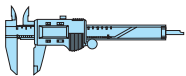

RESOURCES

Sizing Equations
• Guided screw actuators

J-18

Axi-dyne® Basic Sizing Equations

MOTOR SELECTION

INTRODUCTION

To determine the correct motor selection, it is first necessary to calculate the motor torque required for a direct drive system. This is done by setting the reduction ratio and efficiency to one and the reduction and motor inertia to zero. This will result in a torque required directly at the input to the actuator. By using the motor/drive, speed/torque curves found in Section F for Brushless motors, Section G for Microstepping motors and Section H for brushed dc motors, a suitable motor and drive combination can be selected. If a motor is not available that produces the required torque or the inertia ratio is not in a valid range, a reduction will be required. Both belt and planetary gearhead reductions are available (see relevant actuator section in this catalog for ratio's available for each actuator family). Recalculate the motor torque using the new reduction ratio and its efficiency. Once a motor and reduction have been determined, calculate the selected motor's inertia (motor uses some of its available torque to accelerate the rotor, reducing torque available to accelerate the actuator).

SERVO MOTOR SYSTEM

Servo motor systems have two speed/torque curves: one for continuous duty operation and another for intermittent duty. A servo system can be selected according to the total torque and maximum velocity indicated by the continuous duty curve. However, by calculating the root mean square (RMS) torque based on the application duty cycle, you may be able to take advantage of the higher peak torque available in the intermittent duty range. The RMS torque must fall within the continuous duty region of the motor/drive and the application maximum must fall under the peak torque of the motor. Use the following formula when calculating the RMS torque. When selecting a servo motor, it is necessary to add a margin of safety to the torque required to move the load. The recommended margin for servo motors is 15%.

$$T_{RMS} = \sqrt{\frac{T_a^2 t_a + T_c^2 t_c + T_d^2 t_d + T_{dwell}^2 t_{dwell}}{T}} \quad \text{RMS Torque}$$

T_a = Torque during the acceleration motion segment.
 t_a = acceleration time
 T_c = Torque during the constant speed motion segment
 t_c = constant speed time
 T_d = Torque during the deceleration motion segment.
 t_d = deceleration time
 T_{dwell} = Torque used during the dwell motion segment.
 t_{dwell} = dwell time
 T = Total time for the move

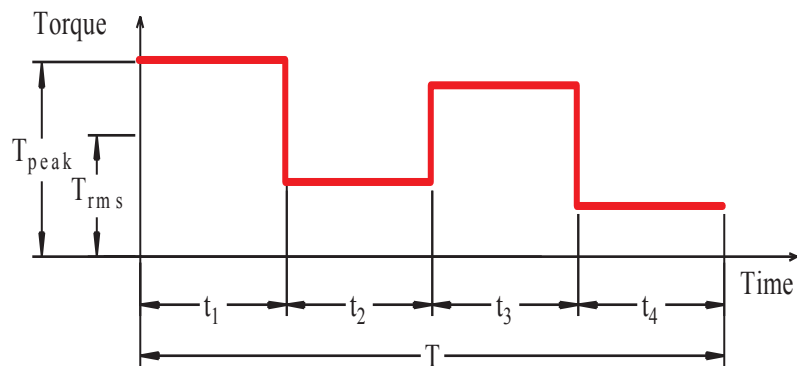

STEPPER MOTOR SYSTEM

Microstepping motor systems have speed/torque curves based on continuous duty operation. To choose a stepper motor, take the peak torque from the application and add a 50% torque margin. When using the published torque curves, the intersection of the torque and the application speed must be below the curve for the selected motor.

Inertia Ratio

The inertia ratio is the ratio of load inertia over the motor inertia. If high load to motor inertia mismatch exists, it can result in load instabilities for compliant systems. The closer the inertia ratio is to one, the better the dynamic response of the motor. The following table shows the recommended inertia ratio's for the different motor types.

MOTOR TYPE	INERTIA RATIO
Brushless Servo	0.1 < Inertia ratio < 10
Brush Servo	0.1 < Inertia ratio < 10
Stepper	0.1 < Inertia ratio < 10

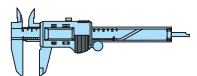

RESOURCES

Sizing Equations
 • Motor selection

Axi dyne® Basic Sizing Equations

MOTOR SELECTION

REQUIRED INFORMATION, CALCULATIONS

Required information

J_{base} = Inertia of the base actuator.....	= _____	(lbs.-in. ²)
J_{stroke} = Inertia of the actuator per inch of stroke.....	= _____	($\frac{\text{lbs.-in.}^2}{\text{in.}}$)
$stroke$ = Stroke length of the actuator.....	= _____	(in.)
$T_{preload}$ = Preload torque of the actuator.....	= _____	(lbs.-in.)
π =	= 3.142	
p = Pitch of the screw in Turns Per Inch (TPI).....	= _____	
e = Efficiency of the screw or belt	= _____	
n = Reduction ratio between the motor and the actuator.....	= _____	
e_n = Efficiency of the reduction	= _____	
J_n = Inertia of the reduction device	= _____	(lbs.-in. ²)
J_{motor} = Inertia of the motor	= _____	(lbs.-in. ²)
r = Radius of the drive belt pulley	= _____	(in.)
J_{pulley} = Inertia of the drive belt pulleys	= _____	(lbs.-in. ²)
T = Total thrust	= _____	(lbs.)

Calculations (Enter your application values designated in light blue.)

Inertia of the load being moved:

SCREW-DRIVE

$$J_{load} = \frac{\frac{W_{load}}{g}}{(2 \cdot \pi \cdot p)^2 \cdot n^2} = \frac{[\frac{W_{load}}{386.098}]}{(2 \cdot [3.142] \cdot [p])^2 \cdot [n]^2} = \text{_____} \text{ (lbs.-in.}^2\text{)}$$

BELT-DRIVE

$$J_{load} = \frac{W_{load}}{g} \cdot \frac{r^2}{n^2} = \frac{[\frac{W_{load}}{386.098}]}{[n^2]} \cdot \frac{[r^2]}{[n^2]} = \text{_____} \text{ (lbs.-in.}^2\text{)}$$

Torque to accelerate load:

SCREW-DRIVE

$$T_{accel} = 2 \cdot \pi \cdot p \cdot a \left(\frac{J_{load}}{e} \cdot \frac{n}{e_n} + (J_{base} + J_{stroke} \cdot stroke) \cdot \frac{n}{e_n} + J_n + J_{motor} \right)$$

$$2 \cdot [3.142] \cdot [p] \cdot [a] \left(\left[\frac{J_{load}}{e} \right] \cdot \left[\frac{n}{e_n} \right] + ([J_{base}] + [J_{stroke}] \cdot [stroke]) \cdot \left[\frac{n}{e_n} \right] + [J_n] + [J_{motor}] \right) = \text{_____} \text{ (lbs.-in.}^2\text{)}$$

BELT-DRIVE

$$T_{accel} = \frac{a}{r} \left(\frac{J_{load}}{e} \cdot \frac{n}{e_n} + (J_{base} + J_{stroke} \cdot stroke) \cdot \frac{n}{e_n} + J_n + J_{pulleys} + J_{motor} \right)$$

$$\left[\frac{a}{r} \right] \left(\left[\frac{J_{load}}{e} \right] \cdot \left[\frac{n}{e_n} \right] + ([J_{base}] + [J_{stroke}] \cdot [stroke]) \cdot \left[\frac{n}{e_n} \right] + [J_n] + [J_{pulleys}] + [J_{motor}] \right) = \text{_____} \text{ (lbs.-in.}^2\text{)}$$

Torque to overcome gravity:

SCREW-DRIVE

$$T_{gravity} = \frac{F_{gravity}}{2 \cdot \pi \cdot p \cdot e_{screw} \cdot n \cdot e_n} = \frac{[F_{gravity}]}{[2] \cdot [3.142] \cdot [p] \cdot [e_{screw}] \cdot [n] \cdot [e_n]} = \text{_____} \text{ (lbs.-in.)}$$

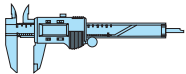

RESOURCES

Sizing Equations
• Motor selection

MOTOR SELECTION

CALCULATIONS (continued)

Torque to overcome gravity:

BELT-DRIVE

$$T_{gravity} = \frac{F_{gravity} \cdot r}{e \cdot n \cdot e_n} = \frac{[F_{gravity}] \cdot [r]}{[e] \cdot [n] \cdot [e_n]} = \text{_____ (lbs.-in.)}$$

Torque to overcome external friction:

SCREW-DRIVE

$$T_{friction} = \frac{F_{friction}}{2 \cdot \pi \cdot p \cdot e_{screw} \cdot n \cdot e_n} = \frac{[F_{friction}]}{[2] \cdot [3.142] \cdot [p] \cdot [e_{screw}] \cdot [n] \cdot [e_n]} = \text{_____ (lbs.-in.)}$$

BELT-DRIVE

$$T_{friction} = \frac{F_{friction} \cdot r}{e \cdot n \cdot e_n} = \frac{[F_{friction}] \cdot [r]}{[e] \cdot [n] \cdot [e_n]} = \text{_____ (lbs.-in.)}$$

Torque to overcome external force:

SCREW-DRIVE

$$T_{ext} = \frac{F_{ext}}{2 \cdot \pi \cdot p \cdot e_{screw} \cdot n \cdot e_n} = \frac{[F_{ext}]}{[2] \cdot [3.142] \cdot [p] \cdot [e_{screw}] \cdot [n] \cdot [e_n]} = \text{_____ (lbs.-in.)}$$

BELT-DRIVE

$$T_{ext} = \frac{F_{ext} \cdot r}{e \cdot n \cdot e_n} = \frac{[F_{ext}] \cdot [r]}{[e] \cdot [n] \cdot [e_n]} = \text{_____ (lbs.-in.)}$$

Maximum RPM of the motor:

SCREW-DRIVE

$$RPM = V_{max} \cdot p \cdot n = [V_{max}] \cdot [p] \cdot [n] = \text{_____ (lbs.-in.)}$$

BELT-DRIVE

$$RPM = \frac{30 \cdot V_{max} \cdot n}{\pi \cdot r} = \frac{[30] \cdot [V_{max}] \cdot [n]}{[3.142] \cdot [r]} = \text{_____ (lbs.-in.)}$$

Torque during the acceleration motion segment: SCREW-DRIVE & BELT-DRIVE

$$T_a = T_{gravity} + T_{friction} + T_{acc} + T_{breakaway} + T_{ext}$$

$$T_a = [T_{gravity}] + [T_{friction}] + [T_{acc}] + [T_{breakaway}] + [T_{ext}] = \text{_____ (lbs.-in.)}$$

Torque during the constant speed motion segment: SCREW-DRIVE & BELT-DRIVE

$$T_c = T_{gravity} + T_{friction} + T_{breakaway} + T_{ext}$$

$$T_c = [T_{gravity}] + [T_{friction}] + [T_{breakaway}] + [T_{ext}] = \text{_____ (lbs.-in.)}$$

Torque during the deceleration motion segment: SCREW-DRIVE & BELT-DRIVE

$$T_d = T_{gravity} + T_{friction} + T_{acc} - T_{breakaway} + T_{ext}$$

$$T_d = [T_{gravity}] + [T_{friction}] + [T_{acc}] - [T_{breakaway}] + [T_{ext}] = \text{_____ (lbs.-in.)}$$

Torque during the dwell motion segment: SCREW-DRIVE & BELT-DRIVE

$$T_{dwell} = T_{gravity} - T_{friction} - T_{breakaway} + T_{ext}$$

$$T_{dwell} = [T_{gravity}] - [T_{friction}] - [T_{breakaway}] + [T_{ext}] = \text{_____ (lbs.-in.)}$$

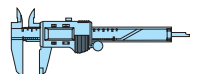

RESOURCES

- Sizing Equations
- Motor selection

Axi dyne® Basic Sizing Equations

MOTOR SELECTION

CALCULATIONS (continued)

Root Mean Square (RMS) torque (required for servo motor sizing)

$$T_{RMS} = \sqrt{\frac{T_a^2 t_a + T_c^2 t_c + T_d^2 t_d + T_{dwell}^2 t_{dwell}}{T}}$$

$$T_{RMS} = \sqrt{\frac{[T_a]^2 [t_a] + [T_c]^2 [t_c] + [T_d]^2 [t_d] + [T_{dwell}]^2 [t_{dwell}]}{[T]}} = \text{_____ (lbs.-in.)}$$

Peak torque during the motion segments

$$T_{max} = \text{_____} = \text{_____ (lbs.-in.)}$$

Torque margin for the motor type selected

$$M = (1.15 \text{ for servo motors}), (2.0 \text{ for stepper motors}) \text{_____} = \text{_____ (lbs.-in.)}$$

Continuous torque required at the motor

$$T_{cont} = T_{RMS} \cdot M = [T_{RMS}] \cdot [M] \text{_____} = \text{_____ (lbs.-in.)}$$

Peak torque required at the motor

$$T_{peak} = T_{max} \cdot M = [T_{max}] \cdot [M] \text{_____} = \text{_____ (lbs.-in.)}$$

Inertia of the actuator and load at the input.

SCREW-DRIVE

$$J_{total} = J_{load} + J_{base} + J_{stroke} \cdot stroke + J_n = [J_{load}] + [J_{base}] + [J_{stroke}] \cdot [stroke] + [J_n] = \text{_____ (lbs.-in.}^2\text{)}$$

BELT-DRIVE

$$J_{total} = J_{load} + J_{base} + J_{stroke} \cdot stroke + J_{pulleys} + J_n$$

$$J_{total} = [J_{load}] + [J_{base}] + [J_{stroke}] \cdot [stroke] + [J_{pulleys}] + [J_n] \text{_____} = \text{_____ (lbs.-in.}^2\text{)}$$

Inertia of the motor

$$J_{motor} = \text{_____} = \text{_____ (lbs.-in.}^2\text{)}$$

Inertia ratio of the load vs the motor

$$I_{ratio} = \frac{J_{total}}{J_{motor}} = \frac{[J_{total}]}{[J_{motor}]} \text{_____} = \text{_____ (lbs.-in.}^2\text{)}$$

Total thrust: SCREW-DRIVE

$$T = 2 \cdot \pi \cdot p \cdot e \cdot e_n \cdot n \left[T_a - \left((J_{base} + J_{stroke} \cdot stroke) \frac{n}{e_n} + J_n + J_{motor} \right) \cdot \frac{2 \cdot \pi \cdot p \cdot a}{g} - T_{breakaway} - T_{friction} \right]$$

$$T = 2 \cdot [3.142] \cdot [e] \cdot [e_n] \cdot [n] \left[[T_a] - \left(([J_{base}] + [J_{stroke}] \cdot [stroke]) \left[\frac{n}{e_n} \right] + [J_n] + [J_{motor}] \right) \cdot \frac{[2] \cdot [3.142] \cdot [p] \cdot [a]}{[g]} - [T_{breakaway}] - [T_{friction}] \right] \text{_____} = \text{_____ (lbs.)}$$

Total thrust: BELT-DRIVE

$$T = \frac{e \cdot e_n \cdot n}{r} \left[T_a - \left((J_{base} + J_{stroke} \cdot stroke + J_{pulleys}) \frac{n}{e_n} + J_n + J_{motor} \right) \cdot \frac{a}{g \cdot r} - T_{breakaway} - T_{friction} \right]$$

$$T = \frac{[e] \cdot [e_n] \cdot [n]}{[r]} \left[[T_a] - \left(([J_{base}] + [J_{stroke}] \cdot [stroke] + [J_{pulleys}]) \left[\frac{n}{e_n} \right] + [J_n] + [J_{motor}] \right) \cdot \frac{[a]}{[g] \cdot [r]} - [T_{breakaway}] - [T_{friction}] \right] \text{_____} = \text{_____ (lbs.)}$$

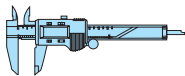

RESOURCES

Sizing Equations
• Motor selection

Axi *dyne*® **Terms and Conditions of Sale**

1. **ORDER ACCEPTANCE.** All orders or services are subject to acceptance in Minnesota by the written approval of an authorized official of Tol-O-Matic, Inc. Any such order shall be subject to these Terms and Conditions of Sale, and acceptance shall be conditioned on Purchaser's assent to such conditions. Purchaser's assent shall be deemed given unless Purchaser shall expressly notify Tol-O-Matic, Inc. in writing to the contrary within five (5) days after receipt of acknowledgment to confirmation of an order.

2. **CANCELLATION AND CHANGES.** No order accepted by Tol-O-Matic, Inc. may be modified in any manner by Purchaser unless agreed to in writing, by an authorized official of Tol-O-Matic, Inc.. Order cancellations, including reductions to order quantities, and changes shall be governed by the following:

- a. Any standard product order scheduled for shipment within five (5) working days of purchaser's request to cancel or modify will be shipped as previously acknowledged and purchaser agrees to accept shipment and payment responsibility, in full, at the price agreed upon.
- b. "Customer Special" orders scheduled for shipment within twenty (20) working days of purchaser's request to cancel or modify will be shipped as previously acknowledged and purchaser agrees to accept shipment and payment responsibility, in full, at the price agreed upon.
- c. All work in connection with "Customer Special" orders, not covered under Paragraph b, will be stopped immediately upon notification, and purchaser agrees to reimburse Tol-O-Matic, Inc. for all work-in-process and any materials or supplies used, or for which commitments have been made by Tol-O-Matic, Inc. in connection therewith.

3. **QUOTATIONS AND PRICES.** Written quotations automatically expire 30 calendar days from the date issued unless terminated sooner by written notice. (Verbal quotations expire, unless accepted in writing, the same day.)

All published prices and discounts are subject to change without notice. In the event of a net price change, the price of product(s) on order will be the price in effect on the date of order acknowledgment. Any addition to an outstanding order will be accepted at prices in effect when the addition is made.

4. **MINIMUM BILLING.** Orders amounting to less than \$35.00 net will be billed at \$35.00
5. **TAXES.** Any Manufacturer's Tax, Retailers Occupation Tax, Use Tax, Sales Tax, Excise Tax, Duty, Customer, Inspection or Testing Fee, or any other tax, fee or charge of any nature whatsoever, imposed by any government authority, on or measured by any transactions between Tol-O-Matic, Inc. and Purchaser shall be paid by the Purchaser in addition to the prices quoted or involved. In the event Tol-O-Matic, Inc. shall be required to pay any such tax, fee or charge, Purchaser shall reimburse therefore.
6. **TERMS OF PAYMENT.** Net invoice amount is due within 30 days from date of invoice subject to credit approval. A 2% per month service charge

shall apply to all invoices not paid within 30 days. All clerical errors are subject to correction. Any invoice in not paid within 60 days will subject that account to an immediate shipping hold.

7. **F.O.B. POINT.** All sales are F.O.B. Tol-O-Matic, Inc.'s facility in Hamel, Minnesota, unless quoted otherwise.
8. **DELIVERY.** Delivery of product(s) by Tol-O-Matic, Inc. to a carrier shall constitute delivery to Purchaser, and regardless of freight payment, title and all risk or loss or damage in transit shall pass to Purchaser at that time.

Should shipment be held beyond scheduled date, upon request of Purchaser, product will be billed and Purchaser agrees to accept any charges for warehousing, trucking and other expenses as may be incident to such delay.

Great care is taken by Tol-O-Matic, Inc. in crating its product. Tol-O-Matic, Inc. cannot be held responsible for breakage after having received "In Good Order" receipts from the transporting carrier. All claims for loss and damage must be made by Purchaser to the carrier within 14 days from receipt of goods. Tol-O-Matic, Inc. will assist insofar as practical in securing satisfactory adjustment of such claims wherever possible.

Claims for shortages or other errors must be made, in writing, within ten (10) days to Tol-O-Matic, Inc. and any additional expense of the method or route of shipment specified by Purchaser shall be borne by the Purchaser.

9. **SHIPPING SCHEDULES.** All quoted shipping schedules are approximate and will depend upon prompt receipt from Purchaser of confirming copy of Purchase Order. Dimensional drawings and specifications submitted by Tol-O-Matic, Inc. to Purchaser for approval must be returned to Tol-O-Matic, Inc. within 10 working days, with approval granted, and any exceptions noted, in order to avoid delay in manufacturing schedules.

Orders which include penalty clauses for failure to meet shipping schedules will not be acceptable, except in those cases specifically approved in writing by the General Manager of Tol-O-Matic, Inc..

Tol-O-Matic, Inc. shall not be liable for damage as a result of any delay due to any cause beyond Tol-O-Matic, Inc.'s reasonable control, including, without limitation, an Act of Nature; act of Purchaser; embargo, or other government act, regulation or request; fire; accident; strike; slow down; war; riot; flood; delay in transportation; and inability to obtain necessary labor, materials or manufacturing facilities. In the event of any such delay, the date of delivery shall be extended for a period equal to the time loss by reason of the delay. The acceptance of the product when delivered shall constitute a waiver of all claims for damages caused by any such delays.

10. **RETURN OF PRODUCT.** No product may be returned without first obtaining a Return Goods Authorization form and confirming memorandum from Tol-O-Matic, Inc.. Product, if accepted for credit, shall be subject to a minimum service charge of 35% of the invoice price and all

transportation charges shall be prepaid by the Purchaser; however, assembled products classified as "special," such as Cable Cylinders and other products which have been modified or built as "Customer Specials," are not returnable to Tol-O-Matic, Inc..

11. **WARRANTY.** Tol-O-Matic, Inc., WARRANTS PRODUCT MANUFACTURED BY IT TO BE FREE FROM DEFECTS IN MATERIAL AND WORKMANSHIP FOR A PERIOD OF ONE YEAR FROM DATE OF SHIPMENT BY Tol-O-Matic, Inc.. IF WITHIN SUCH PERIOD ANY SUCH PRODUCT SHALL BE PROVED TO Tol-O-Matic, Inc.'s SATISFACTION TO BE SO DEFECTIVE, SUCH PRODUCT SHALL EITHER BE REPAIRED OR REPLACED AT Tol-O-Matic, Inc.'s OPTION.

THIS WARRANTY SHALL NOT APPLY:

- a. TO PRODUCT NOT MANUFACTURED BY Tol-O-Matic, Inc. WITH RESPECT TO PRODUCT NOT MANUFACTURED BY Tol-O-Matic, Inc.. THE WARRANTY OBLIGATIONS OF Tol-O-Matic, Inc. SHALL IN ALL RESPECTS CONFORM AND BE LIMITED TO THE WARRANTY ACTUALLY EXTENDED TO Tol-O-Matic, Inc. BY ITS SUPPLIER.
- b. TO PRODUCT WHICH SHALL HAVE BEEN REPAIRED OR ALTERED BY PARTIES OTHER THAN Tol-O-Matic, Inc. SO AS, IN Tol-O-Matic, Inc.'s JUDGMENT, TO AFFECT THE SAME ADVERSELY, OR
- c. TO PRODUCT WHICH SHALL HAVE BEEN SUBJECT TO NEGLIGENCE, ACCIDENT, OR DAMAGE BY CIRCUMSTANCES BEYOND THE CONTROL OF Tol-O-Matic, Inc. OR TO IMPROPER OPERATION MAINTENANCE OR STORAGE, OR TO OTHER THAN NORMAL USE AND SERVICE.

THE FOREGOING WARRANTIES ARE EXCLUSIVE AND IN LIEU OF ALL OTHER EXPRESS AND IMPLIED WARRANTIES WHATSOEVER, INCLUDING BUT NOT LIMITED TO IMPLIED WARRANTIES OF MERCHANTABILITY AND FITNESS FOR A PARTICULAR PURPOSE, Tol-O-Matic, Inc. SHALL NOT BE SUBJECT TO ANY OTHER OBLIGATIONS OR LIABILITIES WHATSOEVER WITH RESPECT TO PRODUCT MANUFACTURED OR SUPPLIED BY Tol-O-Matic, Inc. OR SERVICE RENDERED BY IT.

12. **CONSEQUENTIAL DAMAGE.** Tol-O-Matic, Inc., shall not, under any circumstances be liable for consequential damages.
13. **SERVICE CHARGES.** Should the Purchaser request the service of any erector, demonstrator or service man (except as specifically provided for and included in the price of the product) such service will be rendered at the rate outlined in the schedule of field service charges in effect at the date of request.

TOL-O-MATIC MAKES PRODUCTS FOR ANYTHING THAT MOVES!



PNEUMATIC



BC2 Band Cylinder
CATALOG NUMBER 9900-4000

PNEUMATIC



PB2 Power-Block2 Rod Cylinder Slide
CATALOG NUMBER 9900-4000

PNEUMATIC



Vane Rotary Actuator
CATALOG NUMBER 9900-4000

AXIDYNE ELECTRIC



BCS Screw-Drive Linear Actuator
CATALOG NUMBER 3600-4609

AXIDYNE ELECTRIC



B3S Screw-Drive Linear Actuator
CATALOG NUMBER 3600-4609

PNEUMATIC



BC3 Band Cylinder
CATALOG NUMBER 9900-4000

PNEUMATIC



PB Power-Block Rod Cylinder Slide
CATALOG NUMBER 9900-4000

PNEUMATIC



RA Rack & Pinion Rotary Actuator
CATALOG NUMBER 9900-4000

POWER TRANSMISSION



Caliper Disc Brakes
CATALOG NUMBER 9900-4009

AXIDYNE ELECTRIC



B3B Belt-Drive Linear Actuator
CATALOG NUMBER 3600-4609

AXIDYNE ELECTRIC



TKS/B TruTrack Linear Actuator
CATALOG NUMBER 3600-4613

PNEUMATIC



BC4 Band Cylinder
CATALOG NUMBER 9900-4000

PNEUMATIC



RCS Rod Cylinder Slide
CATALOG NUMBER 9900-4000

PNEUMATIC



PAS PrecisionAire™ Systems
CATALOG NUMBER 3604-4134

POWER TRANSMISSION



Adam & Disc Cone Clutches
CATALOG NUMBER 9900-4009

POWER TRANSMISSION



Slide Rite™ Gearbox
CATALOG NUMBER 0100-4000

AXIDYNE ELECTRIC



MRV, MRS, MRB Motors
CATALOG NUMBER 3600-4609

PNEUMATIC



LS Linear Slide
CATALOG NUMBER 9900-4000

PNEUMATIC



MG Mag. Coupled Cylinder
CATALOG NUMBER 9900-4000

PNEUMATIC



GP Angular & Parallel Grippers
CATALOG NUMBER 9900-4000

POWER TRANSMISSION



Float-A-Shaft Gear Drives
CATALOG NUMBER 9900-4009

AXIDYNE ELECTRIC



Controllers, Drives, Interfaces
CATALOG NUMBER 3600-4609

AXIDYNE ELECTRIC



SLS Screw-Drive Linear Actuator
CATALOG NUMBER 3600-4609

PNEUMATIC



MGS Mag. Coupled Slide
CATALOG NUMBER 9900-4000

PNEUMATIC / HYDRAULIC



CC Cable Cylinder
CATALOG NUMBER 9900-4000

PNEUMATIC



RG RotoGripper
CATALOG NUMBER 9900-4000

AXIDYNE ELECTRIC



GSA Guided Screw Actuator
CATALOG NUMBER 3600-4609

AXIDYNE ELECTRIC



RSA Rod Screw Actuator
CATALOG NUMBER 3600-4609



TOL-O-MATIC

3800 County Road 116 • Hamel, MN 55340, U.S.A.

Phone: (763) 478-8000 • Fax: (763) 478-8080 • Toll-Free: 1-800-328-2174
U.S. and Canada

URL: <http://www.Tolomatic.com>

Email: help@Tolomatic.com