

# HARDWARE & INSTALLATION GUIDE

## ACS – Actuator Control Solutions Stepper Drive/Controller and Motors

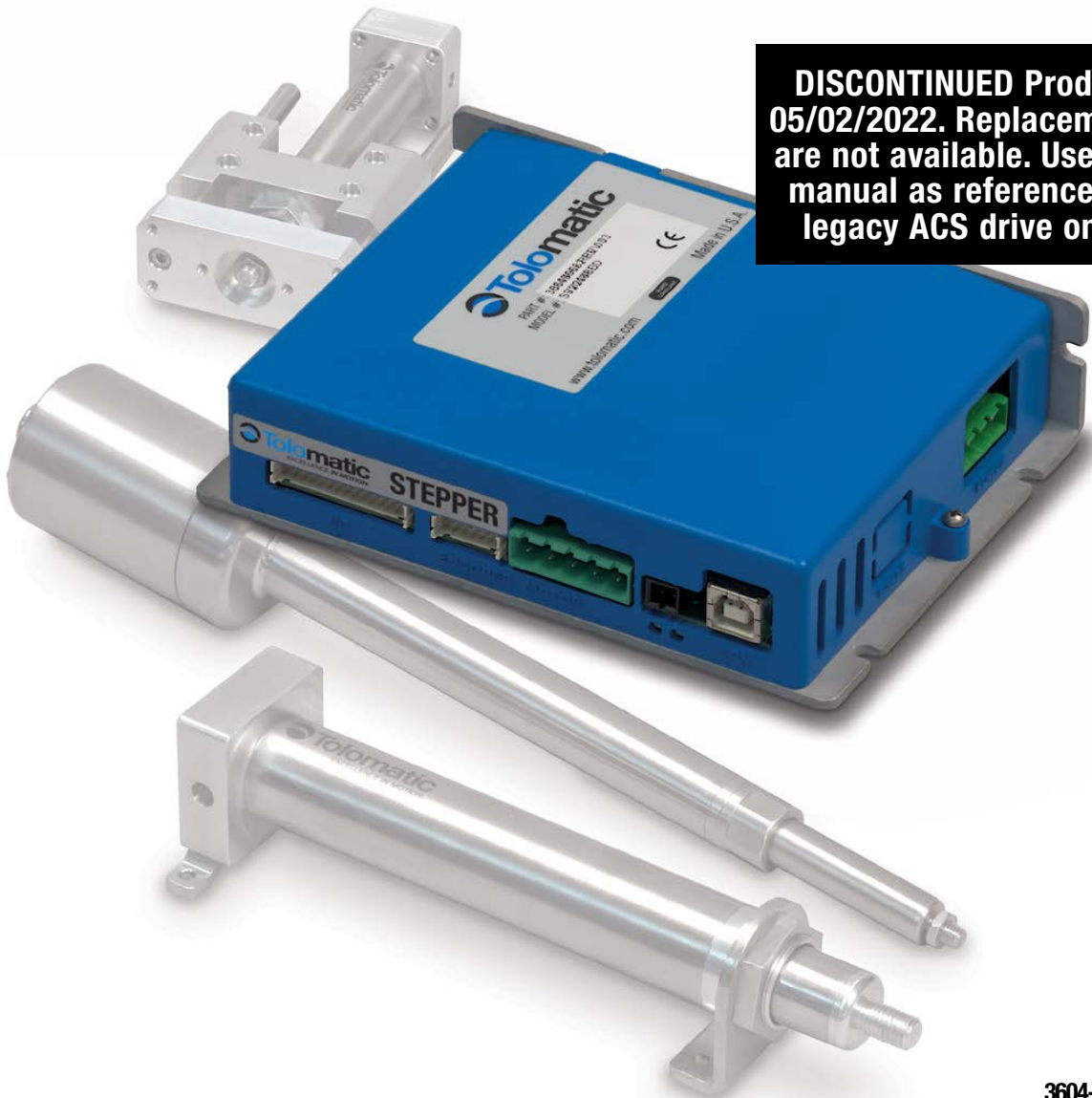

**DISCONTINUED Product**  
05/02/2022. Replacements  
are not available. Use this  
manual as reference for  
legacy ACS drive only.

3604-4183\_11



3800 County Road 116, Hamel, MN 55340

Phone: 763.478.8000

Toll Free: 1.800.328.2174

Fax: 763.478.8080

Email: [help@tolomatic.com](mailto:help@tolomatic.com)

**[www.tolomatic.com](http://www.tolomatic.com)**

Original Instructions - English

Translations will be supplied in other community languages as required by customers

Copyright © 2022 Tolomatic, Inc. All rights Reserved.

All brand and product names are trademarks of their respective owners. Information in this document is believed to be accurate at time of publication.

Tolomatic reserves the right to change the design or operation of the equipment described herein and any associated motion products without notice. Information in this document is subject to change without notice.

202204111422

<b>List of Figures</b> .....	5
<b>List of Tables</b> .....	iv
<b>Health and Safety Regulations</b> .....	7
Safety Symbols .....	7
EMC Wiring Guidelines .....	8
Proper and Safe Use of Product.....	vi
Handling and Unpacking .....	9
Product Warnings.....	9
<b>1. Product Overview</b> .....	10
1.1 The ACS Drive/Controller for Actuator Control Solutions.....	10
1.1.1 The ACS Drive Overview.....	10
1.1.2 Optional Accessories.....	11
<b>2. Environment, Dimensions &amp; Mounting</b> .....	12
2.1 Operating Environment.....	12
2.2 Dimensions .....	12
2.3 Mounting the ACS Drive .....	13
<b>3. CD &amp; USB Cable</b> .....	14
<b>4. ACS Drive Setup</b> .....	15
4.1 ACS Drive and Actuator Basic Setup .....	15
4.1.1 Setup Procedures .....	16
<b>5. Connections &amp; Cables</b> .....	17
5.1 Connections & Cables Overview .....	17
5.2 Motor Power Connection and Cable .....	17
5.3 Encoder Connection and Cable .....	18
5.4 I/O Connection and Cable.....	19
5.5 Input Power Connection .....	21
5.6 Brake Output Connection .....	21
5.7 USB 2.0 Connection.....	22
5.8 RS-485 Connection .....	22
5.8.1 RS-485 Cable Length.....	22
5.8.2 RS-485 Grounding .....	23
5.9 Ethernet Connection.....	23
5.10 Cable Routing.....	23
5.10.1 Ethernet Cable .....	24
5.10.2 Ethernet Cable Length .....	24
<b>6. Specifications and Wiring</b> .....	25

# CONTENTS

---

6.1 Digital Inputs.....	25
6.1.1 Specifications.....	25
6.1.2 Typical Wiring Diagrams.....	25
6.2 Digital Outputs.....	26
6.2.1 Specifications.....	26
6.2.2 Typical Wiring Diagrams.....	27
6.3 Analog Input.....	28
6.3.1 Specifications.....	28
6.3.2 Equivalent Circuit.....	28
6.4 Analog Output.....	29
6.4.1 Specifications.....	29
6.4.2 Equivalent Circuit.....	29
6.5 Brake Output.....	30
6.5.1 Specifications.....	30
6.5.2 Equivalent Circuit.....	30
6.6 Input Power.....	30
6.6.1 Drive Specifications.....	30
6.6.2 Typical Input Power Wiring.....	31
6.6.3 Power Supply Selection.....	32
6.6.4 Suggested Power Supplies.....	33
<b>7. I/O Timing Diagrams.....</b>	<b>34</b>
7.1 I/O Timing Diagrams.....	34
7.1.1 Move Timing Rules.....	36
<b>8. Move Select Logic.....</b>	<b>37</b>
8.1 Move Select Logic Tables.....	37
<b>9. LED Codes and Faults.....</b>	<b>39</b>
9.1 LED Codes.....	39
9.2 Fault Descriptions and Recovery.....	39
<b>10. Troubleshooting.....</b>	<b>41</b>
10.1.1 Troubleshooting the ACS Drive.....	41
<b>Appendix 1.....</b>	<b>43</b>
Motors.....	43
<b>Appendix 2.....</b>	<b>45</b>
Previous Wiring.....	45
<b>Appendix 3.....</b>	<b>47</b>
Product Warranty.....	47
<b>Appendix 4.....</b>	<b>48</b>
Certification.....	48

# List of Figures

Figure 2-1	ACS Drive Dimensions.....	12
Figure 2-2	Mounting the ACS Drive.....	13
Figure 4-1	ACS Drive and ERD Actuator Basic Setup .....	15
Figure 5-1	Motor Power Connection on ACS Drive.....	17
Figure 5-2	Motor Power Cable 3604-1708 / 1709 / 1710 .....	18
Figure 5-3	Encoder Connection on ACS Drive.....	18
Figure 5-4	Encoder Cable 3604-1768 / 1769 / 1969 .....	19
Figure 5-5	I/O Connection on ACS Drive .....	19
Figure 5-6	I/O Cable 3604-1770 / 1771 .....	20
Figure 5-7	Input Power Connection.....	21
Figure 5-8	Brake Connection.....	21
Figure 5-9	Brake Cable.....	22
Figure 5-10	USB 2.0 Connection .....	22
Figure 5-11	ACS 2-Wire RS485 with RJ45 Socket.....	22
Figure 5-12	Resistors in Ground Wire to Limit Current.....	23
Figure 5-13	EtherNet/IP Connection for ACS Drive Programmability.....	23
Figure 5-14	Cable Routing for Top and Side Mounted Connectors .....	24
Figure 6-1	Digital Input Circuit.....	25
Figure 6-2	Input Source (switched) Connection.....	25
Figure 6-3	Input Source (PNP) Connection .....	26
Figure 6-4	Input Sink (switched) Connection .....	26
Figure 6-5	Input Sink (NPN) Connection .....	26
Figure 6-6	Output Circuit .....	27
Figure 6-7	Digital Output Sinking Connection .....	27
Figure 6-8	Digital Output Sourcing Connection .....	27
Figure 6-9	Analog Input Equivalent Circuit.....	28
Figure 6-10	Analog Output Equivalent Circuit.....	29
Figure 6-11	Brake Output Equivalent Circuit.....	30
Figure 6-12	ACS Drive Logic and Main Power Supplies .....	31
Figure 6-13	ACS Drive Single Supply – Main Power .....	31
Figure 6-14	ACS Drive External Cutoff Switch for Emergency Stop .....	32
Figure 6-15	Unregulated Power Supply Configuration with Shunt Regulator .....	32
Figure 6-16	Regulated Power Supply Configuration with Blocking Diode .....	33
Figure 6-17	Regulated Power Supply with Blocking Diode and Shunt Regulator .....	33
Figure 7-1	Input Requirement.....	34
Figure 7-2	System Startup Timing .....	34
Figure 7-3	Jog Move Timing.....	34
Figure 7-4	Absolute & Incremental Move Timing.....	35
Figure 7-5	Brake Subsystem Timing .....	35

# List of Tables

---

Table 2-1	ACS Drive Operating Conditions .....	12
Table 3-1	CD and USB cable part numbers.....	14
Table 5-1	Motor Power Connection pinouts.....	17
Table 5-2	Motor Power Cable and Connector Parts .....	18
Table 5-3	Encoder Connection pinouts .....	18
Table 5-4	Encoder Cable and Connector Parts .....	19
Table 5-5	I/O Connection pinouts .....	20
Table 5-6	I/O Cable and Connector Parts.....	20
Table 5-7	Input Power pinouts .....	21
Table 5-8	Input Power Cable Parts .....	21
Table 5-9	Brake Pinout.....	21
Table 5-10	EtherNet/IP pinouts and Connections.....	23
Table 6-1	Opto-isolated Digital Input Specifications .....	25
Table 6-2	Digital Output Specifications .....	27
Table 6-3	Analog Input Specifications.....	28
Table 6-4	Analog Output Specifications .....	29
Table 6-5	Brake Output Specifications.....	30
Table 6-6	ACS Internal Drive Specifications .....	30
Table 6-7	Maximum Power Supply Current for Tolomatic Motors.....	32
Table 8-1	4 Move Commands Mode Logic.....	37
Table 8-2	8 Move Commands Mode Logic.....	37
Table 8-3	16 Move Commands Mode Logic.....	38
Table 9-1	LED Indicators.....	39
Table 9-2	Safety Faults.....	40
Table 9-3	Critical Faults.....	40
Table 10-1	Troubleshooting Descriptions .....	42
Table A-1	Tolomatic Stepper Motor Specifications .....	43
Table A-2	Tolomatic Stepper Motor Part Numbers .....	43
Table A-3	Encoder Specifications .....	43
Table A-4	NEMA11, 17, 23 Motor Connection pinouts.....	44
Table A-5	NEMA34 Motor Connection pinouts.....	44
Table A-6	NEMA11, 17, 23 Encoder Connections and Connector pinouts .....	44
Table A-7	NEMA 34 - Encoder Connections and Connector pinouts .....	44
Table A-8	Previous Revisions of Wire Colors for Motor Power Connection pinouts .....	45

# Health and Safety Regulations

---

Read through the applicable sections of the manual before the equipment is unpacked, installed or operated. Pay attention to all of the dangers, warnings, cautions and notes stated in the manual.

Serious injury to persons or damage to the equipment may result if the information in the manual is not followed.

## ■ Safety Symbols

Items that are specifically marked DANGER!, WARNING!, CAUTION! or NOTE! are arranged in a hierarchical system and have the following meaning:



### **DANGER!**

Indicates a very hazardous situation which, if not avoided, could result in **death or serious injury**. This signal word is limited to the most extreme situations.



### **WARNING!**

Indicates a potentially hazardous situation which, if not avoided, could result in **death or serious injury**.



### **CAUTION!**

Indicates a potentially hazardous situation which, if not avoided, may result in property damage, minor or moderate injury.



### **CAUTION!**

Indicates hot surfaces. Avoid contact.

### **NOTE!**

Information that requires special attention is stated here.

## ■ EMC Wiring Guidelines

### Cable routing

It is recommended that the power and signal cables for the ACS Drive be routed as far apart as possible to minimize system noise.

**NOTE!** The standard cables from Tolomatic are not flex rated and have a minimum bend radii of 3.75 inches. Any repeated flexing or excessive bending can result in broken conductors and intermittent faults.

### Shielding and grounding

When cabling the system, high quality braided or foil with braided shielded cables are recommended. The standard motor cables provided by Tolomatic have a braided shield with drain wires. The metal angle bracket on the drive/controller is also a case ground and should be tied to earth ground. To minimize EMI and ensure system reliability, all shield drain wires from all cables should be tied to a common earth ground.



### WARNING!

**The manufacturer takes no responsibility whatsoever if the equipment is modified or if the equipment is used in any way beyond performance specifications. Unauthorized modifications or changes to the equipment are strictly forbidden and void all warranties.**



### WARNING!

**Incorrect wiring can feedback through the USB port and damage your computer. Use good wiring practices to prevent ground loops.**

## ■ Proper and Safe Use of Product

### Protection circuits and external fuses

A fuse should be added to the input power line to protect the drive/controller and power supply from any potential over current conditions that may occur. (See Section 6: Specifications & Wiring)

### Fail Safe Emergency Stop Recommendations

A fail safe e-stop is highly recommended to ensure equipment and personal safety. The e-stop should provide a means to remove main power from the actuator to cease and prevent any unwanted motion.

### Device Damage Prevention

To prevent permanent damage to the device, proper care should be taken not to exceed published voltage, current, temperature, and load ratings. In addition, proper wiring should be verified and safety measures checked before applying power.

### Personal Safety

During normal operation the motor can become hot. It is highly recommended to display proper safety notices and implement proper safety measures to prevent contact with hot surfaces.





## CAUTION!

**Proper ESD measures should be taken to avoid static electricity from contacting the signal and power lines of the drive, motor and encoder.**

## ■ Handling and Unpacking

When unpacking and handling, care should be taken not to drop the drive/controller as this can damage the connectors and internal electronics.

## ■ Product Warnings

The following precautions should be observed to prevent erratic behavior or damage:

- Do not short circuit the motor power at the power connector. Doing so may damage the drive power electronics. The motor/cable is part of the current regulation circuitry. For a short occurring in a motor, the motor leads should provide enough resistance and inductance to prevent dangerous peak currents from occurring.
- Do not reverse bias the drive power.
- Do not apply voltages above the maximum rated voltage.
- Do not expose drive to conductive contaminants, moisture, or excessive temperature.
- Do not disassemble or modify the drive/controller.
- Do not plug and unplug cables while the drive is energized.

## ■ Wiring for CE Compliance

- Use a braided shield motor cable such as Igus Chainflex CF140US-07-04.
- See Section 5-2 for motor cable description.

## 1.1 The ACS Stepper Drive/Controller for Actuator Control Solutions

Tolomatic's ACS Drive/Controller is a stepper drive and controller intended for use with electric actuators. Tolomatic's Motion Interface software allows the user to select the compatible Tolomatic electric linear actuator of choice. The software automatically sets most of the necessary parameters to create the desired motion of the selected actuator reducing setup and programming time. (See Tolomatic Motion Interface Software Manual 3600-4167 for more information).

Currently there are three ACS Drive/Controller choices:

- #3604-9665 - ACS Stepper Drive/Controller, Modbus RTU over RS485  
- firmware 36043183UD.tol
- #3604-9666 - ACS Stepper Drive/Controller, EtherNet/IP (Analog Output)  
- firmware 36043183UD.tol
- #3604-9667 - ACS Stepper Drive/Controller, Modbus TCP (Analog Output)  
- firmware 36043183UD.tol

 NOTE: They will collectively be referred to as ACS Drive throughout this guide

### 1.1.1 ACS Stepper Drive/Controller — Overview

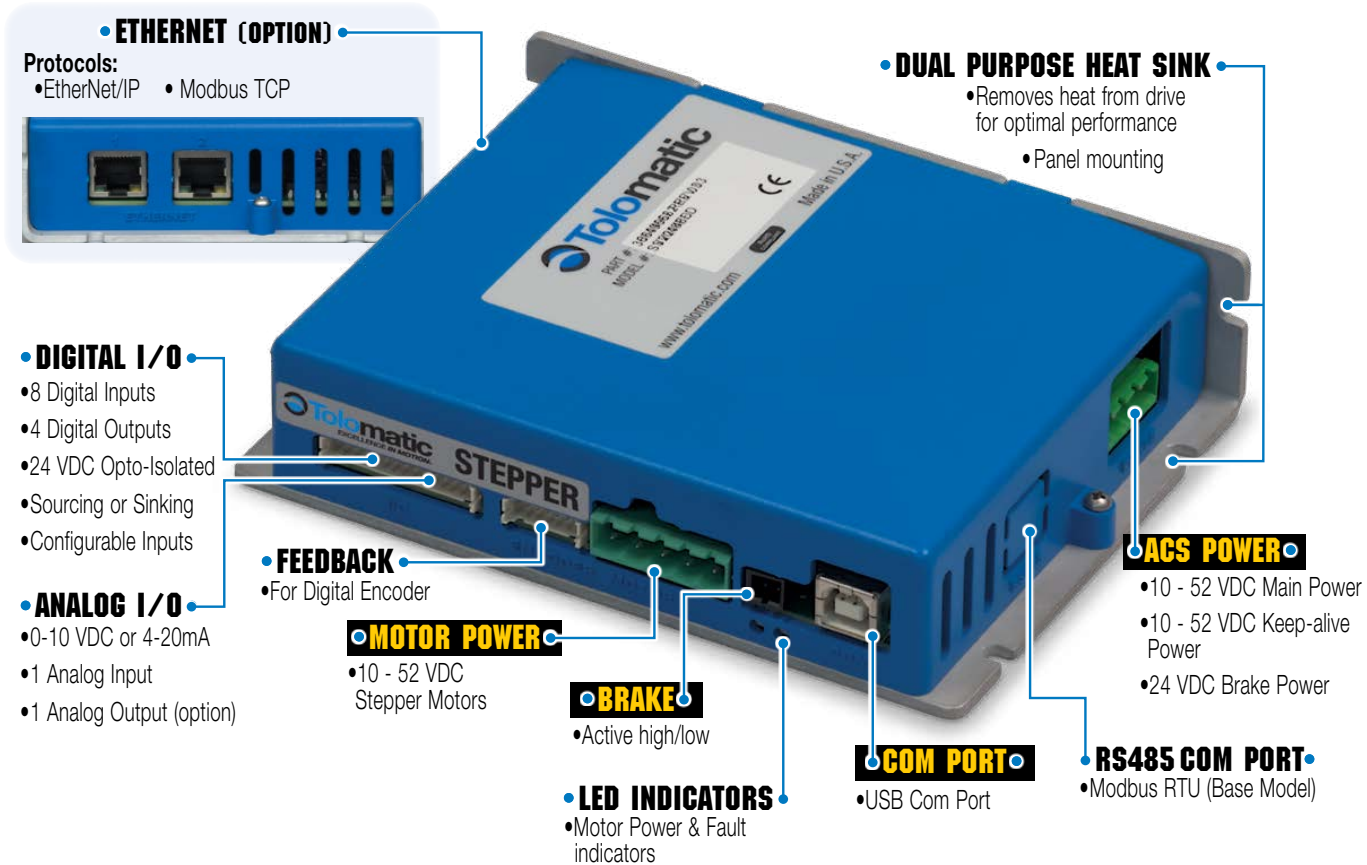

# 1: PRODUCT OVERVIEW

## ACS Drive/Controller (3604-9665) Capabilities

- 4, 8, or 16 move command modes (absolute, incremental and jog or home with analog output echoing position of actuator from encoder) for infinite position capability
- Analog position mode (0-10 VDC or 4-20 mA)
- Pneumatic mode replaces pneumatic valve logic for simple motion
- ModBus RTU over RS485 provides infinite positioning
- Adjustable motion profile parameters (velocity, accel/decel, force). Parameters are independently configurable for each move
- Ability to reduce holding current for energy savings
- End point correction
- Zone output based on position
- Force limiting capability
- Configurable digital I/O (24 VDC Opto-Isolated) (sourcing or sinking)
- Compatible with most 24/48 VDC stepper motors

## ACS Drive/Controller (3604-9666, 3604-9667) Additional Capabilities

- EtherNet mode provides infinite positioning using EtherNet/IP and Modbus TCP protocols
- Dual EtherNet port with internal switch for easy daisy chaining
- Analog output for Analog Position Mode

## 1.1.2 Optional Accessories

### Cable Options



Tolomatic offers a motor power cable with drive and motor mating connectors, an encoder cable with drive and encoder connectors, and an I/O cable with drive mating connector to flying leads. Cables are available in 3, 5 or 10 meter lengths.

### Disc and Cable



Tolomatic software is always available online at [www.tolomatic.com](http://www.tolomatic.com). For your convenience a software CD and optional USB computer connections are available:

Tolomatic Motion Interface Software CD (3604-9526) and a USB Type B cable (3604-1852)

### Brake Cable



Tolomatic offers a 5-meter brake power cable with drive and brake mating connectors

# Environment, Dimensions & Mounting

# 2

## 2.1 Operating Environment



### WARNING!

Do not expose the drive to conductive contaminants, moisture, or exceed temperature ratings.

The ACS Drive is designed to be operated in ambient conditions from 0° – 40°C (32° – 104°F), and humidity from 0 – 90% non-condensing. There is no ingress protection (IP) for the drive, so it is important to protect the drive from water and other conductive contamination. In addition, proper ESD procedures should be observed to prevent static discharge and damage to electronic components.

ACS Drive Operating Conditions	
Ambient Temperature	77° F, 25° C Nominal
Operating Temperature	32°-104° F, 0°-40° C Non Freezing
Storage Temperature	32°-158° F, 0°-70° C
Humidity	0-90% non-condensing

Table 2-1: ACS Drive Operating Conditions

## 2.2 ACS Drive Dimensions

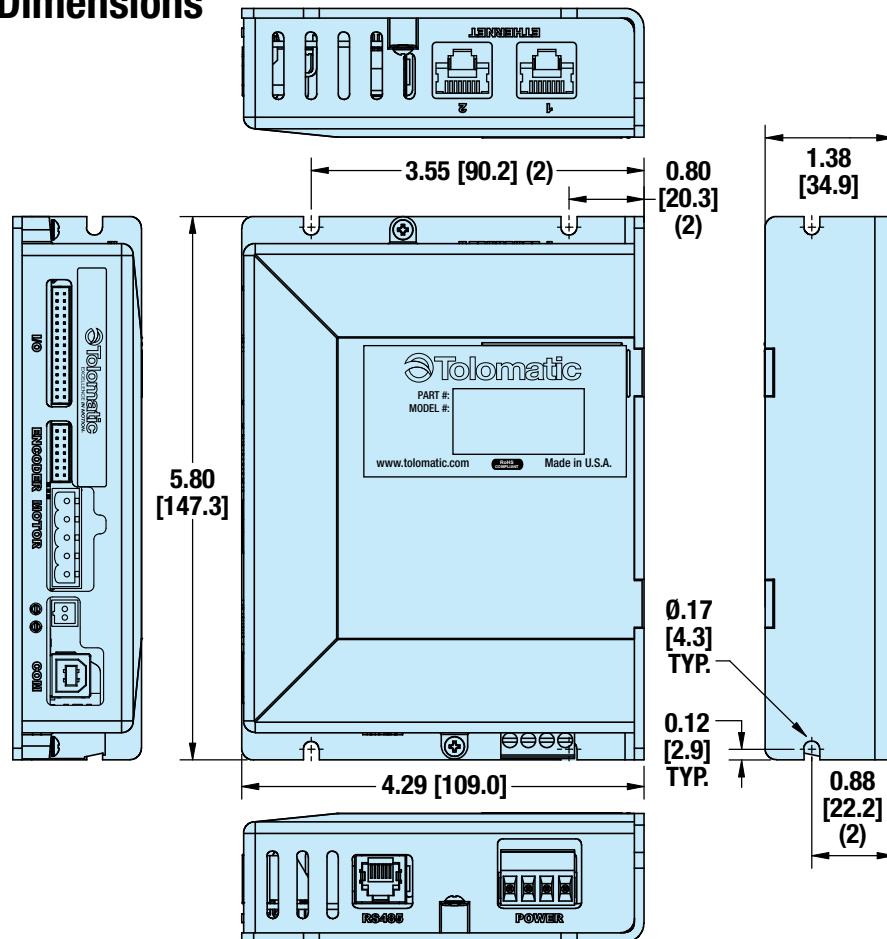

Figure 2-1: ACS Drive Dimensions

### 2.3 Mounting the ACS Drive

The drive/controller is intended to be mounted vertically (as shown in Figure 2-2) to provide the vents with enough clearance on the top and bottom of the drive to allow for air flow. The metal bracket should also be mounted to a metal surface for best thermal dissipation. A 2-inch head space is recommended from the drive vents to another surface to ensure the proper ambient temperature ratings are maintained.

It is recommended to have a minimum of 1-inch spacing between drives. This spacing may be relaxed provided the ambient temperature is kept within limits and the drive is mounted to a metal surface suitable enough to heat sink the drives.

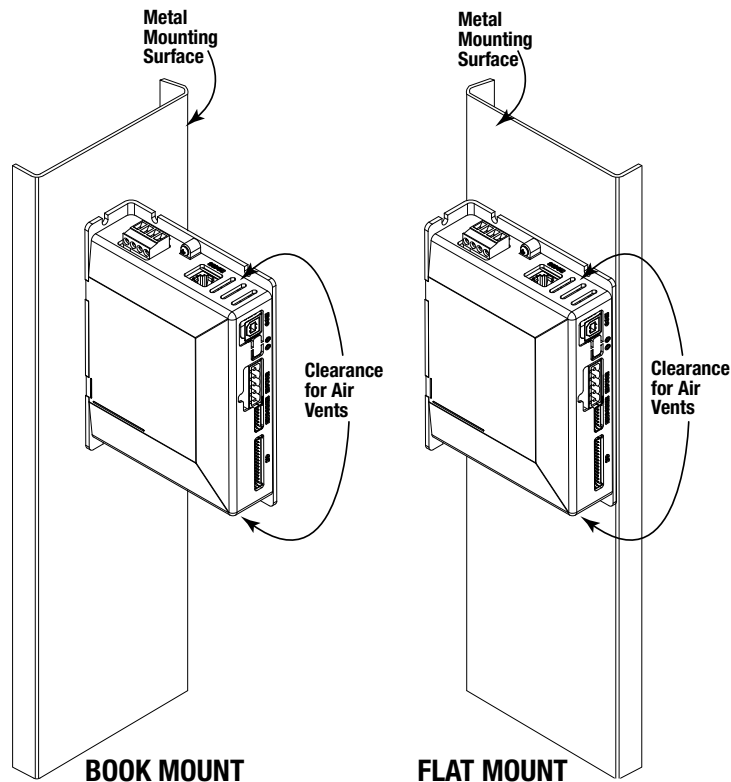



Figure 2-2 Mounting the ACS Drive

## 3.1 CD & USB Cable

 **NOTE:** The most current version of software and firmware is always available at [www.tolomatic.com](http://www.tolomatic.com)

Tolomatic offers a CD with Tolomatic Motion Interface software, drive firmware and firmware upgrade utility. A USB type B cable is also available for connecting your computer to the ACS drive.



ACS Drive Accessories	
ITEM	TOLOMATIC PART NUMBER
Tolomatic Motion Interface Software CD	3604-9526
1 meter USB Cable	3604-1852

**Table 3-1: CD and USB cable part numbers.**

## 4.1 ACS Drive and Actuator Basic Setup

Figure 4-1 shows the simple setup of the ACS Drive, the Tolomatic ERD actuator and the necessary cables and power source.

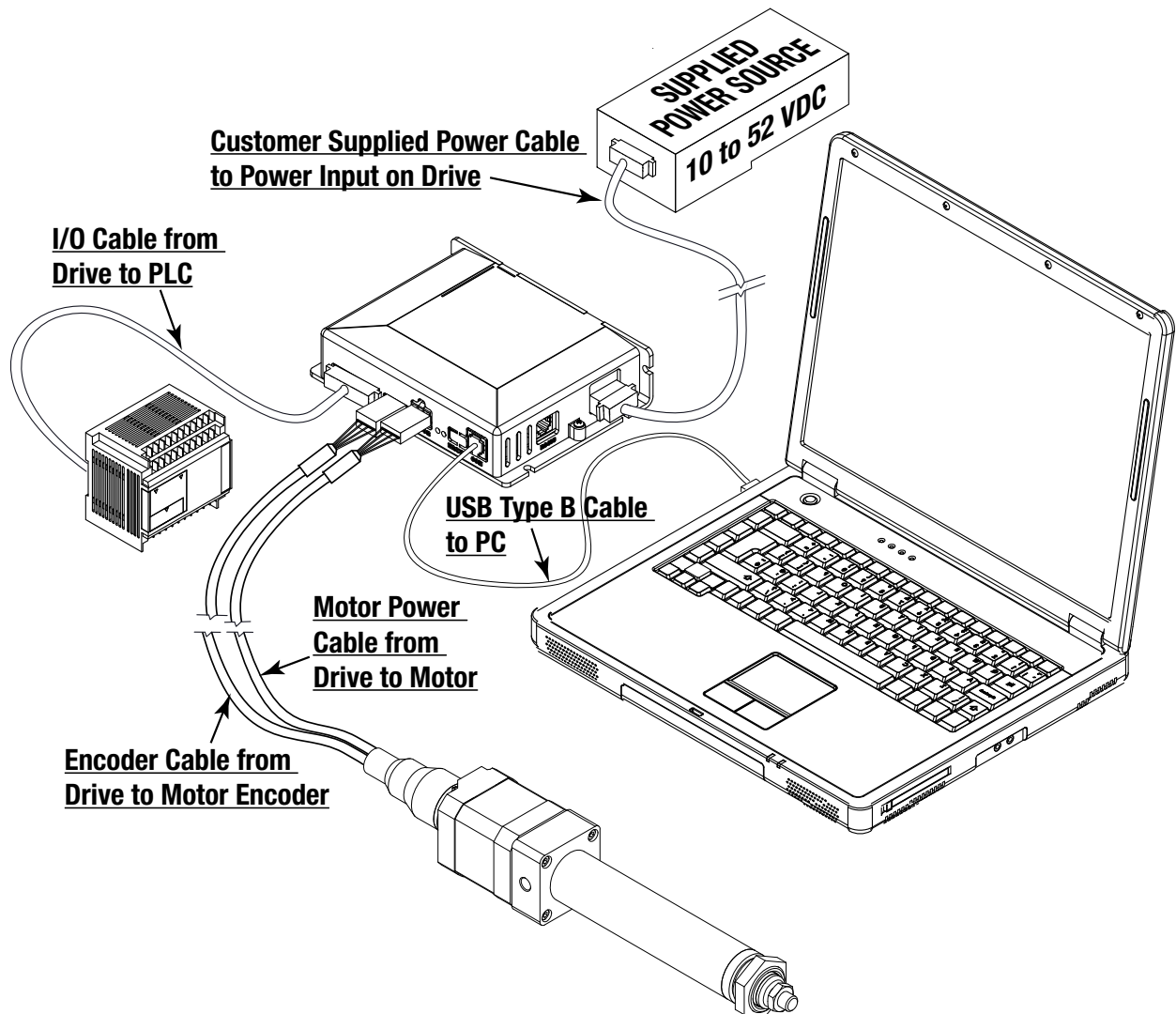

**Figure 4-1: ACS Drive and ERD Actuator– Basic Setup**

Please refer to the following sections and page numbers for cable part numbers and wiring specifications:

Motor Power Cable: Section 5

Encoder Cable: Section 5

I/O Cable: Section 5

USB: Section 5

For recommended power supplies: Section 6

### ■ 4.1.1 Setup Procedures

1. Install drive/controller and actuator into appropriate fixtures.
2. Wire the power supply to the drive. See Section 6: Power Supply Selection.
3. Wire input and output signals to the desired logic device. See Section 5: Connections and Cables.
4. Attach motor and encoder cables.
5. Attach programming cable and install the Tolomatic Motion Interface software.
6. Configure ACS Drive.
7. Program the logic device.



## 5.1 Connections and Cables Overview

All cables for the ACS Drive can be ordered through Tolomatic with the exception of the power supply. When using cables other than those provided by Tolomatic, reference the cable mating connector style to ensure the proper cabling is supplied.

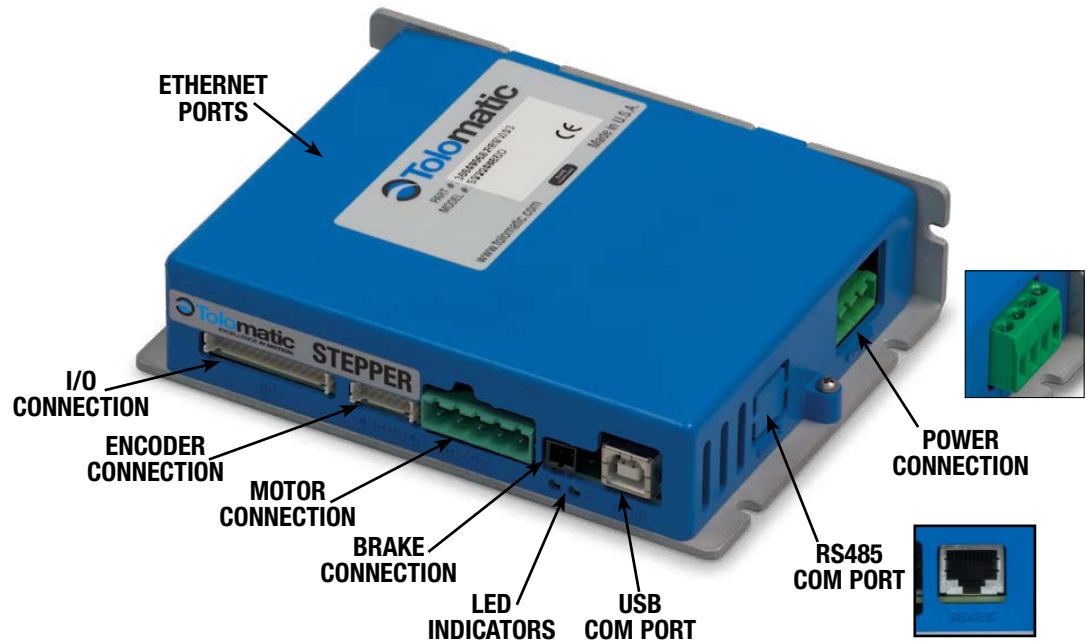

## 5.2 Motor Power Connection and Cables



### WARNING!

Do not connect or disconnect motor cables while the drive is powered.

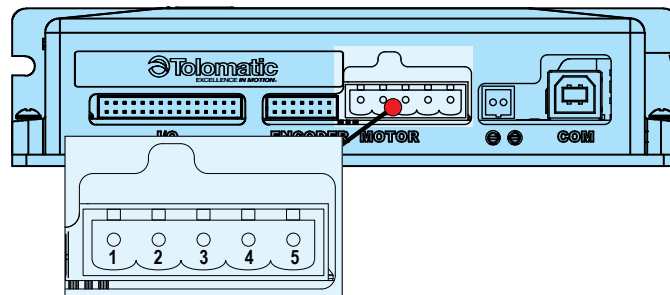

Figure 5-1: Motor Power Connection on ACS Drive

### NOTE!

See Appendix 2 for previous version wire color/pin numbers

ACS CONNECTOR (ON-SHORE) PIN NUMBERS	SIGNAL	CABLE WIRE COLOR 34 REV 1 (11, 17, 23 REV 6)	MOTOR CONNECTOR (TYCO)
1	Motor A-	BRN	6
2	Motor A+	WHT	3
3	Shield	SHIELD	2
4	Motor B+	BLU	1
5	Motor B-	BLK	4

Table 5-1: Motor Power Connection pinouts

## 5: CONNECTIONS & CABLES

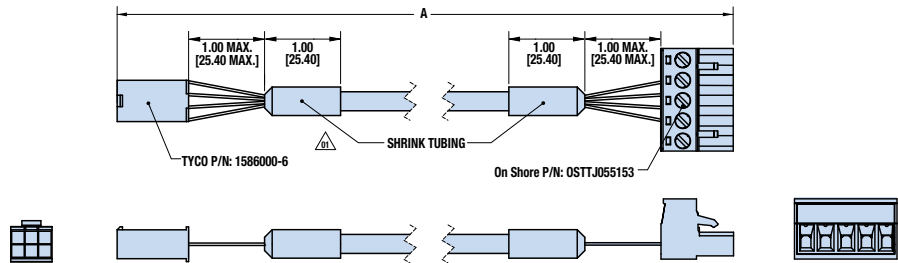

Figure 5-2: Motor Power Cable 3604-1708 / 1709 / 1710 / 2228 / 2229 / 2230

CABLE	TOLOMATIC PART NO.	DRIVE MATING CONNECTOR	MOTOR MATING CONNECTOR	MOTOR CONTACTS	DIM. "A"
Motor Power: 3-meter	3604-1708	On Shore PN OSTTJ055153	Tyco PN: 1586000-6	Tyco PN: 1586314-3	3 m 118"
Motor Power: 5-meter	3604-1709	On Shore PN OSTTJ055153	Tyco PN: 1586000-6	Tyco PN: 1586314-3	5 m 197"
Motor Power: 10-meter	3604-1710	On Shore PN OSTTJ055153	Tyco PN: 1586000-6	Tyco PN: 1586314-3	10 m 394"
34 Motor Power: 3-meter	3604-2228	On Shore PN OSTTJ055153	Phoenix Contact: 1786200	None	3 m 118"
34 Motor Power: 5-meter	3604-2229	On Shore PN OSTTJ055153	Phoenix Contact: 1786200	None	5 m 197"
34 Motor Power: 10-meter	3604-2230	On Shore PN OSTTJ055153	Phoenix Contact: 1786200	None	10 m 394"

Table 5-2: Motor Power Cable and Connector Parts

**NOTE:** For CE compliance use a quality braided shield cable such as Igus Chainflex CF140US-07-04. See Appendix 1 for motor pinout chart.

### 5.3 Encoder Connection and Cable

The ACS Drive has an encoder port that supports differential signal quadrature encoders. Single ended encoders may be used with additional external circuitry. It is highly recommended to use differential encoders as they are more resistant to signal noise. The drive can supply +5VDC power to the feedback device up to 100mA.

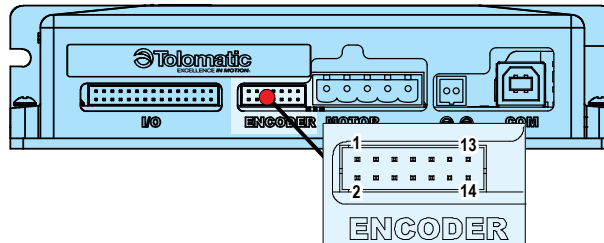

Figure 5-3: Encoder Connection on ACS Drive

PIN NUMBERS	SIGNAL	CABLE WIRE COLOR
1	ENC A+	Blue
2	ENC A-	Orange
3	ENC B+	Yellow
4	ENC B-	Gray
5	No Contact	No Contact
6	No Contact	No Contact
9	Signal Ground	Black
12	+5VDC	Red
13	Case Ground	No Contact

Table 5-3: Encoder Connection pinouts

## 5: CONNECTIONS & CABLES

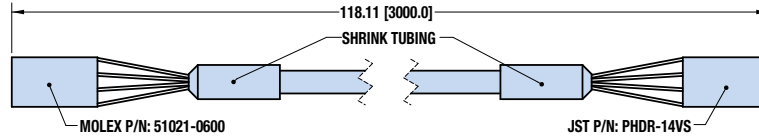

Figure 5-4: Encoder Cable 3604-1768 /1769 /1969

FOR NEMA 11, 17, 23 MOTORS					
CABLE	TOLOMATIC PART NO.	DRIVE MATING CONNECTOR	DRIVE MATING CONTACTS	ENCODER MATING CONNECTOR	ENCODER MATING CONTACTS
Encoder: 3-meter	3604-1768	JST PN: PHDR-14VS	JST PN: SPHD-001T-P0.5	Molex PN: 51021-0600	Molex PN: 50079-8100
Encoder: 5-meter	3604-1769	JST PN: PHDR-14VS	JST PN: SPHD-001T-P0.5	Molex PN: 51021-0600	Molex PN: 50079-8100
Encoder: 10-meter	3604-1969	JST PN: PHDR-14VS	JST PN: SPHD-001T-P0.5	Molex PN: 51021-0600	Molex PN: 50079-8100
FOR NEMA 34 MOTORS					
CABLE	TOLOMATIC PART NO.	DRIVE MATING CONNECTOR	DRIVE MATING CONTACTS	ENCODER MATING CONNECTOR	ENCODER MATING CONTACTS
Encoder: 3-meter	3604-1971	JST PN: PHDR-14VS	JST PN: SPHD-001T-P0.5	Molex PN: 15-04-5104	Molex Inserts PN: 14-60-0058
Encoder: 5-meter	3604-1972	JST PN: PHDR-14VS	JST PN: SPHD-001T-P0.5	Molex PN: 15-04-5104	Molex Inserts PN: 14-60-0058
Encoder: 10-meter	3604-1973	JST PN: PHDR-14VS	JST PN: SPHD-001T-P0.5	Molex PN: 15-04-5104	Molex Inserts PN: 14-60-0058

Table 5-4: Encoder Cable and Connector Parts



NOTE: See Appendix 1 for encoder pinout chart

### 5.4 I/O Connection and Cable

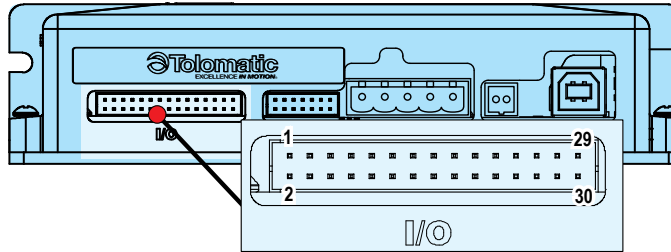

Figure 5-5: I/O Connection on ACS Drive

JST #PHDR-30VS		
PIN NUMBERS	SIGNAL	CABLE WIRE COLOR (REV 5)
1	Input ISO 1	PNK/BLK
2	Input ISO 2	PNK
3	Input ISO 3	RED/WHT
4	Input ISO 4	TEAL/WHT
5	Input ISO 5	BLU/WHT
6	Input ISO 6	YEL/BLK
7	Input ISO 7	YEL
8	Input ISO 8	ORG/WHT

#### NOTE!

See Appendix 2 for previous version wire color/pin numbers

## 5: CONNECTIONS & CABLES

### NOTE!

See Appendix 2 for previous version wire color/pin numbers

JST #PHDR-30VS		
PIN NUMBERS	SIGNAL	CABLE WIRE COLOR (REV 5)
9	Input ISO COM	TEAL/BLK
10	Output 1 -	RED/BLK
11	Output 1 +	WHT
12	Output 2 -	GRN
13	Output 2 +	BLU
14	Output 3 -	GRY/BLK
15	Output 3 +	ORG
16	Output 4 -	ORG/BLK
17	Output 4 +	RED
20	Case Ground	SHIELD
23	*Step Input	BRN/WHT
24	*Direction Input	BRN
25	No Contact	TEAL
26	No Contact	GRY
27	Analog Out	VIO/WHT
28	Analog In	VIO
29	Signal Ground	BLK
30	Signal Ground	BLK/WHT

\*Not yet supported by software

**Table 5-5: I/O Connection pinouts**

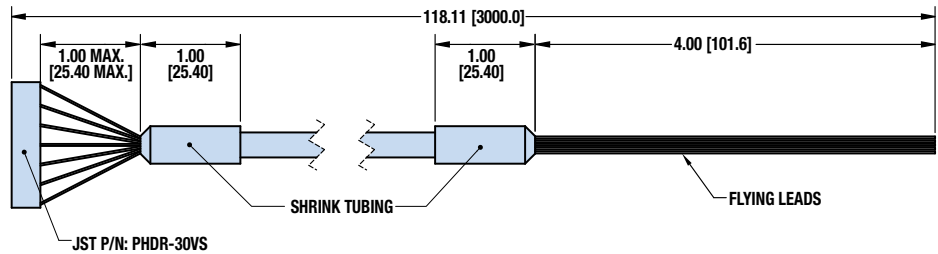

**Figure 5-6: I/O Cable 3604-1770/1771**

CABLE	TOLOMATIC PART NO.	DRIVE MATING CONNECTOR	DRIVE MATING CONTACTS
I/O: 3-meter	3604-1770	JST PN: PHDR-30VS	JST PN: SPHD-001T-P0.5
I/O: 5-meter	3604-1771	JST PN: PHDR-30VS	JST PN: SPHD-001T-P0.5

**Table 5-6: I/O Cable and Connector Parts**

The input power is connected via pins on the drive with customer supplied cabling. The input power mating connector is supplied by Tolomatic.

## 5.5 Input Power Connection



### CAUTION!

Reversing polarity of the input power will damage the drive electronics.

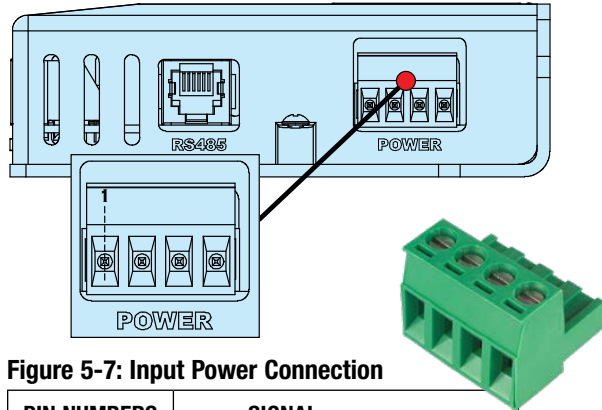
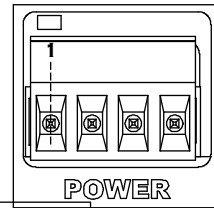

Figure 5-7: Input Power Connection

PIN NUMBERS	SIGNAL
1	Main Power 10 - 52 VDC
2	Keep-alive 10 - 52 VDC
3	Brake Power 24 VDC
4	Ground – Power

Table 5-7: Input Power pinouts



CABLE	INPUT POWER MATING CONNECTOR
Customer Supplied	OnShore PN: ED950/4 - provided

Table 5-8: Input Power Cable Parts

## 5.6 Brake Output Connection

The brake output is controlled via an onboard Circuit Brake Power is supplied via the Input Power Connection and output on the Brake Output Connection.

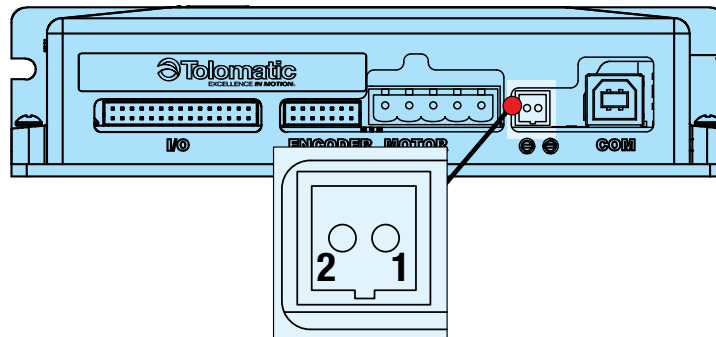

Figure 5-8: Brake Connection

MOLEX #0050579702		M8 CONNECTOR - PHOENIX CONTACT # 1406242	
PIN NUMBERS	FUNCTION	PIN NUMBERS	
1	Brake -	1	<p>Front View</p>
2	Brake +	2	

Table 5-9: Brake Pinout

## 5: CONNECTIONS & CABLES

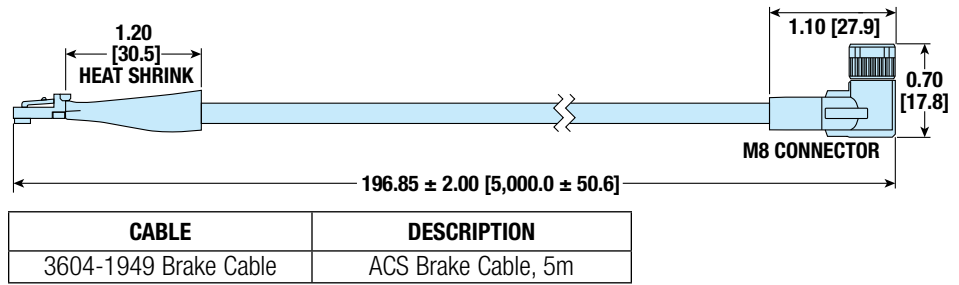

Figure 5-9: Brake Cable

### 5.7 USB 2.0 Connection

The USB port connector is a standard B type connector.

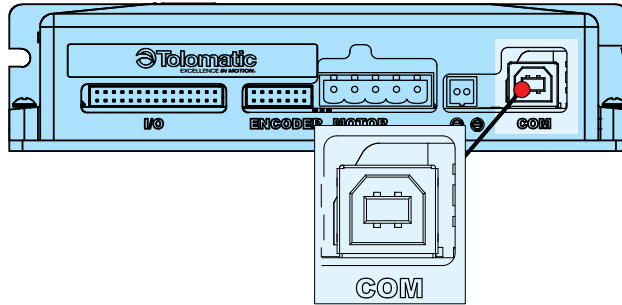

Figure 5-10: USB 2.0 Connection

### 5.8 RS-485 Connection

The ACS RS485 connection requires an RJ45 plug with 3 conductors. The ACS controller/drive uses a two-wire configuration for RS485 connection. This requires three signals: A, B, and Common. Signals A and B are a differential pair. Signals A and B are duplicated on pins 7 and 8. Common is used as a reference voltage. Figure 5-10 shows the pin assignment on the ACS socket.

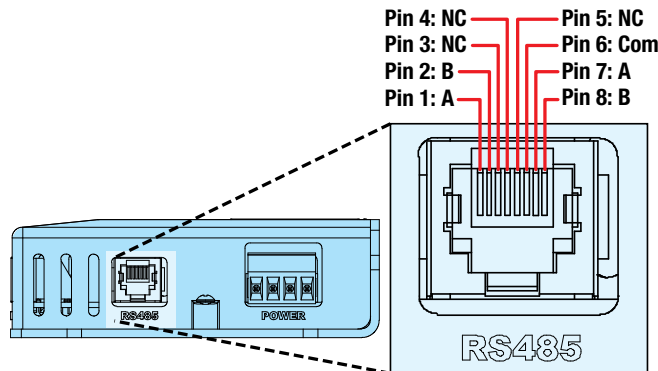

Figure 5-11: ACS 2-Wire RS485 with RJ45 Socket

#### 5.8.1 RS-485 Cable Length

A multipoint serial line bus is made of a main cable (the trunk) which connects to a Master device, and derivation cables that tap off from the trunk to Slave devices. RS-485 transceivers have a wide (-7V to +12V) common mode range. This differential signal has good noise immunity for long distance transmission lines. The absolute maximum cable length of the trunk is 4,000 feet. If more than one

## 5: CONNECTIONS & CABLES

Slave device is tapped from the trunk, then terminating 150 Ohm resistors must be placed across lines A and B at both ends of the trunk. The derivation cable to the Slave device must be short with a maximum cable length of 60 feet. Some factors that may reduce cable length are: the number of devices on a multi-drop application, the quality of cabling used, and the baud rate selected.

### 5.8.2 RS-485 Grounding

The Common wire must be connected to protective ground. This wire should only be connected at one point on the bus, preferably at the Master device. If ground potentials are too large, resistors must be placed in the Common wire at each device to limit the current and prevent damage to the circuit. This is shown in Figure 5-12.

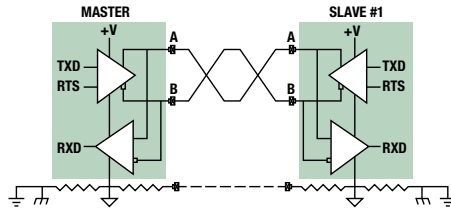

Figure 5-12: Resistors in ground wire to limit current

## 5.9 Ethernet Connection

The following parts have two Ethernet ports with a built-in switch to be used for daisy chaining.

3604-9666 - ACS Stepper Drive/Controller, EtherNet/IP™

3604-9667 - ACS Stepper Drive/Controller, Modbus TCP

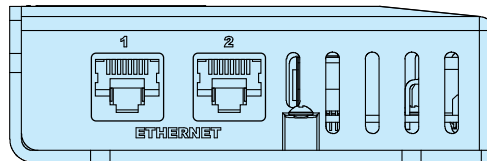
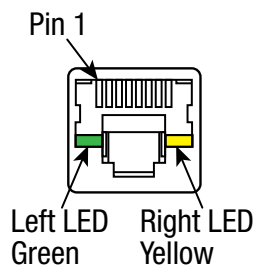

Figure 5-13 EtherNet/IP Connection for ACS Drive Programmability



PIN NUMBER	FUNCTION
1	Transmit Port (+) Data Terminal
2	Transmit Port (-) Data Terminal
3	Receive Port (+) Data Terminal
4	No Contact
5	No Contact
6	Receive Port (-) Data Terminal
7	No Contact
8	No Contact

Table 5-10 EtherNet/IP pinouts and Connections

## 5.10 Cable Routing

Over time, liquid contaminants such as oil and cleaning solutions may accumulate on the cables and in the connectors if they are an exposed type. To minimize the introduction of contaminants into the connector, route the cables so that there is a

loop in the cable just prior to its attachment to the connector.

In Figure 5-14 proper cable looping is shown for connectors located on the top or side of the unit. Units mounted with connectors on the bottom surface require no cable looping.

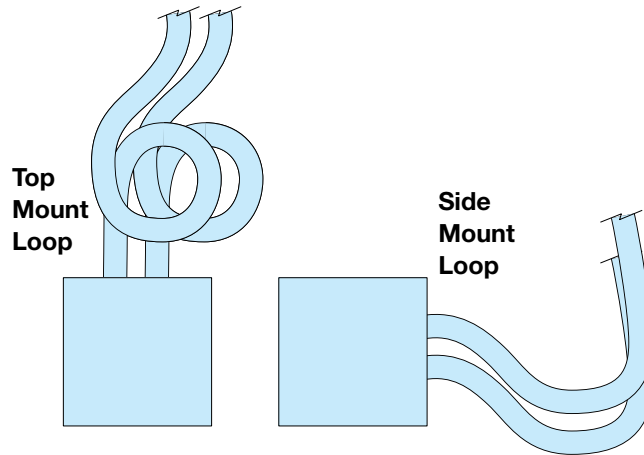

**Figure 5-14 Cable Routing for Top and Side Facing Connectors**

### ■ 5.10.1 Ethernet Cable

The selection of cables has a profound impact on network performance and reliability. Selecting the correct cable requires an understanding of the environment where the cable is installed.

Due to high data rate and reliability considerations, at the minimum, Cat5e cables should be used with the ACS Drive. If the cables are made on site, they must be tested to meet performance criteria set according to TIA/EIA -568-B standard. This cable definition is the general cable requirements for copper and fiber cabling installations.

### ■ 5.10.2 Ethernet Cable Length

The following information regarding cable length is from commercial building telecommunications cabling standard ANSI/TIA/EIA-568-B.1. The maximum length of a cable segment is 100 meters (328 ft). Category 5e cable is capable of transmitting data at speeds up to 1000 Mbps – 1Gbps (ACSI has a maximum speed of 100 Mbps). The specifications for 10BASE-T network-ing specify a 100-meter length between active devices. This allows for 90 meters of fixed cabling, two connectors, and two patch leads of 5 meters, one at each end.



## 6.1 Digital Inputs

### 6.1.1 Specifications

The ACS Drive has a total of 8 opto-isolated digital inputs. These digital inputs are opto-isolated from the controller's drive circuitry and can be wired either as sinking or sourcing. All of the digital inputs have a common return.

NOTE: ACSi supports configuration of a digital input as a limit switch. This configuration requires the use of 'Normally Open' switches

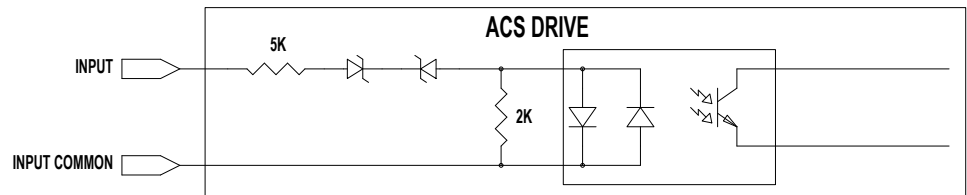

Figure 6-1: Digital Input Circuit

Opto-isolated Digital Input Specifications		
Parameter	Value	Units
Input Voltage Range	0 to 28	VDC
On State Voltage Range	16 to 28	VDC
Off State Voltage Range	0 to 5	VDC
On State Current:		
16VDC (minimum)	1.9	mA
24VDC (nominal)	3.4	
28VDC (maximum)	4.2	
Nominal Input Impedance (24V)	7	KΩ
Off State Current (maximum)	0.4	mA
Update Rate (maximum)	2	ms

Table 6-1: Opto-Isolated Digital Input Specifications

### 6.1.2 Typical Wiring Diagrams

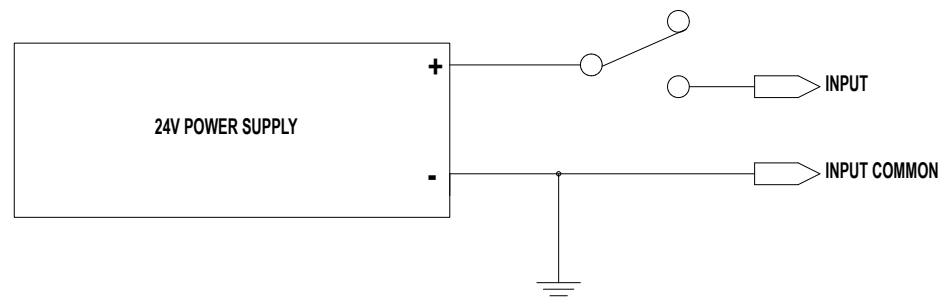

Figure 6-2: Input Source (switched) Connection

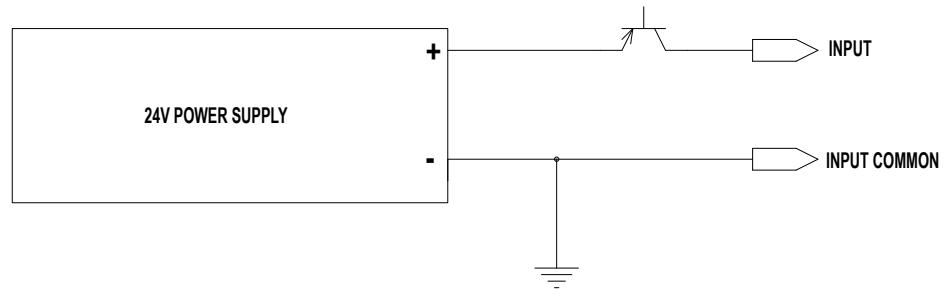

Figure 6-3: Input Source (PNP) Connection

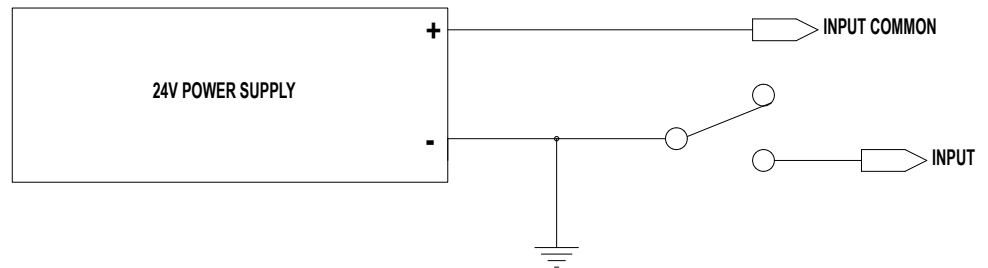

Figure 6-4: Input Sink (switched) Connection

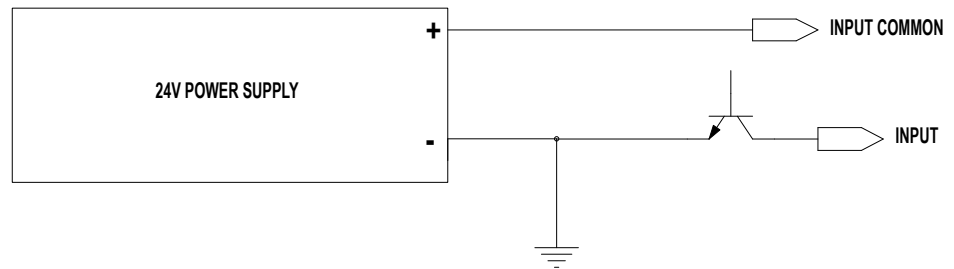

Figure 6-5: Input Sink (NPN) Connection

## 6.2 Digital Outputs

### 6.2.1 Specifications

The ACS Drive has four digital outputs. These digital outputs are opto-isolated from the drive circuitry and can be configured for sinking or sourcing. The outputs are protected against over current and short circuit conditions. If an over current condition is present, the output turns off until the load is removed.

## 6: SPECIFICATIONS & WIRING

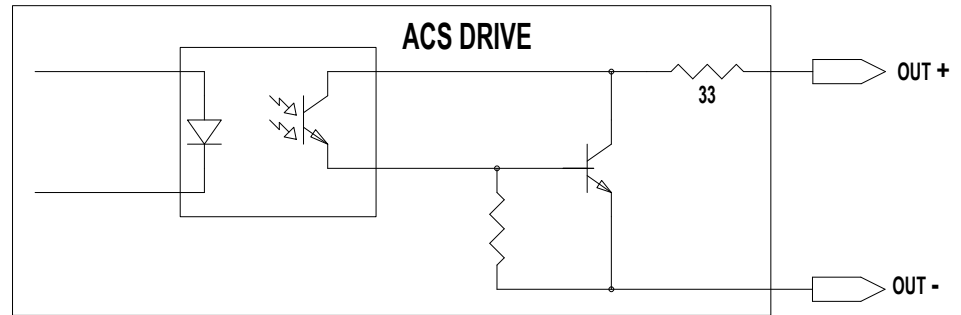

Figure 6-6: Output Circuit

Digital Output Specifications		
Parameter	Value	Units
Switched Voltage (max)	24	V
Output Voltage drop (20mA)	2	V
Continuous Current (max)	20	mA
Fold Back Current	80	mA
Update Rate (10KOhm Load)	2	ms
Output Leakage Current	30	uA

Table 6-2: Digital Output Specifications

### 6.2.2 Typical Wiring Diagrams

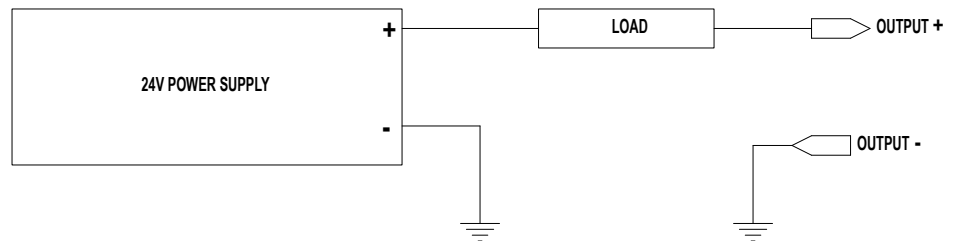

Figure 6-7: Digital Output Sinking Connection

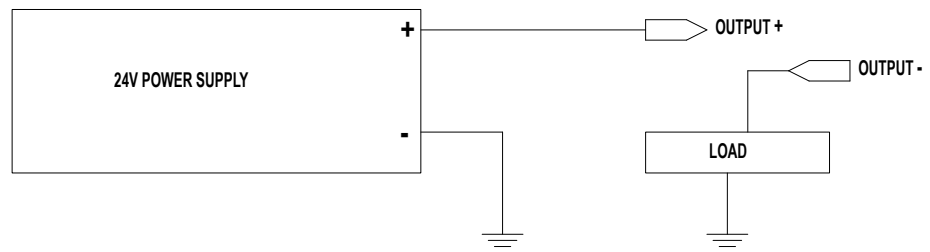

Figure 6-8: Digital Output Sourcing Connection

## 6.3 Analog Input

### 6.3.1 Specifications

The ACS Drive comes with one analog input. The input is configurable through software to be 0-10V or 4-20mA input. The analog input is referenced to the analog ground pin.

Parameter	Value	Units
Voltage Mode Input Voltage (min)	0	V
Voltage Mode Input Voltage (max)	10	V
Current Mode Input Current (min)	4	mA
Current Mode Input Current (max)	20	mA
Current Mode Input impedance (nom)	500	Ohm
Resolution	12	Bits

Table 6-3: Analog Input Specifications

### 6.3.2 Equivalent Circuit

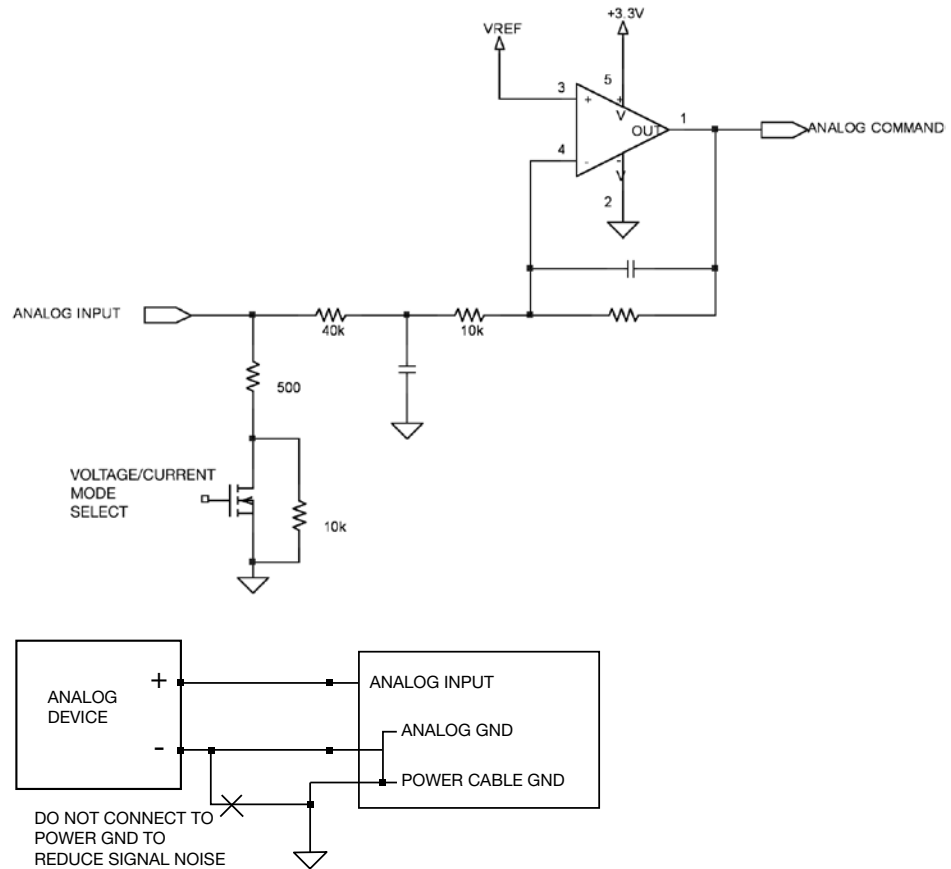

### IMPORTANT!

Devices sharing analog inputs and outputs must have their grounds connected together for proper and reliable operation.

Figure 6-9: Analog Input Equivalent Circuit

## 6.4 Analog Output



**NOTE:**

Analog output only available with EtherNet/IP and Modbus TCP models

### 6.4.1 Specifications

The ACS Drive can have one analog output capable of 0-10V or 4-20mA operation (on EtherNet/IP and Modbus TCP models). The analog output is referenced to the analog output ground pin.

Parameter	Value	Units
Output Voltage (min)	0	V
Output Voltage (max)	10	V
Output Current (min)	4	mA
Output Current (max)	20	mA
Resolution	12	Bits

Table 6-4: Analog Output Specifications



**IMPORTANT!**

Devices sharing analog inputs and outputs must have their grounds connected together for proper and reliable operation.



**IMPORTANT!**

Devices sharing analog inputs and outputs must be referenced to the analog GND pin for proper and reliable operation.



**IMPORTANT!**

The analog GND is shared with the power cable GND internal to ACSi it should be connected to a high impedance or isolated source or else it will sink current from the motor driver potentially causing a noisy signal

### 6.4.2 Equivalent Circuit

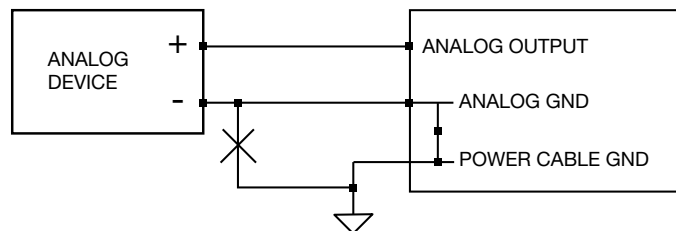
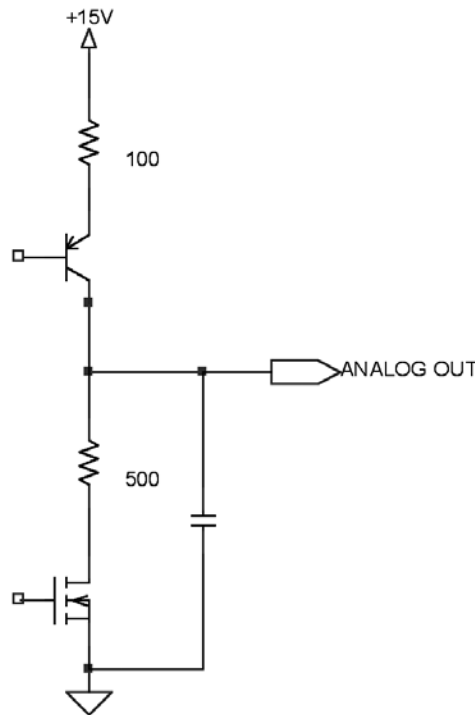

Figure 6-10: Analog Output Equivalent Circuit

## 6.5 Brake Output

### 6.5.1 Specifications

Parameter	Value	Units
Input Voltage	24	V
Absolute Maximum Voltage	70	V
Output Current	0 - 500	mA

Table 6-5: Brake Output Specifications

### 6.5.2 Equivalent Circuit

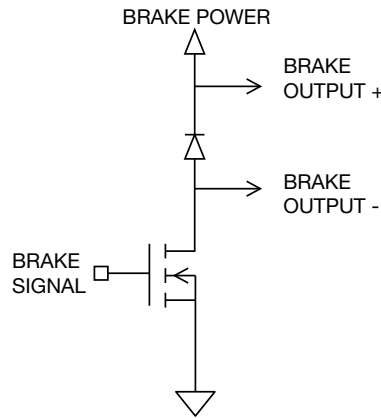

Figure 6-11: Brake Output Equivalent Circuit

## 6.6 Input Power

### 6.6.1 Drive Specifications



#### CAUTION!

Voltage above the absolute maximum can result in permanent damage to the ACS internal drive components.



#### WARNING!

Do not reverse bias the power inputs. Doing so will result in permanent damage to the drive.

ACS Internal Drive Specifications		
Parameter	Value	Units
Current - Maximum	10	A
Voltage - Nominal	10-52	V
Over Voltage <sup>1</sup>	55	V
Under Voltage <sup>2</sup>	9	V
Absolute Maximum Voltage	60	V
Logic Current Draw Maximum (24V)	100	mA

Table 6-6: ACS Internal Drive Specifications

<sup>1</sup> Drive will fault at 55V; any voltage above the absolute max voltage can result in permanent damage.

<sup>2</sup> Drive will fault below 9V.

The drive and logic (keep alive) power share the same ground. Drive logic circuitry can be powered from the keep alive input or the main drive power.



**Keep Alive not required**

Providing 10 to 60Vdc to keep alive maintains the drive logic memory when main power is de-energized; which stops all motion; the drive keeps all control logic active and position information.

**Keep Alive Wiring Diagram**

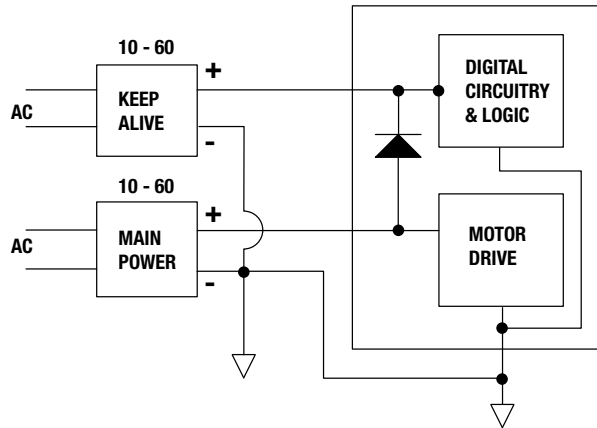

Figure 6-12: Keep Alive wiring diagram



**WARNING!**

Do not short circuit the motor power at the power connector. Doing so may damage the drive power electronics. The motor/ cable is part of the current regulation circuitry. For a short occurring in a motor, the motor leads should provide enough resistance and inductance to prevent dangerous peak currents from occurring.

**6.6.2 Typical Wiring Diagrams**

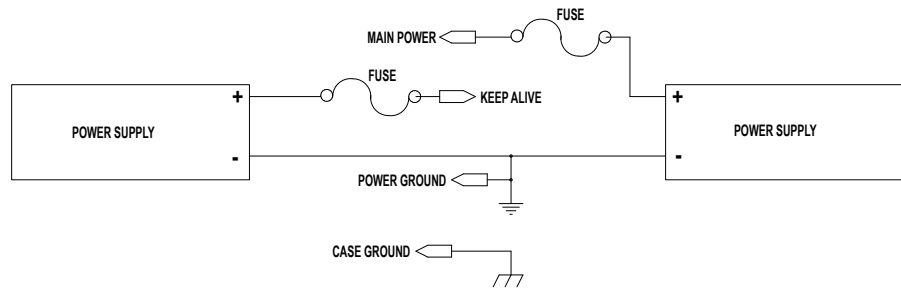

Figure 6-13: ACS Drive Logic and Main Power Supplies



**WARNING!**

All installations should provide a means for a hardware emergency stop that removes power from the drive in an emergency condition. The drive emergency stop function should not be relied on when safety is required. It is recommended to disconnect only the + bus power and keep the power ground line connected.

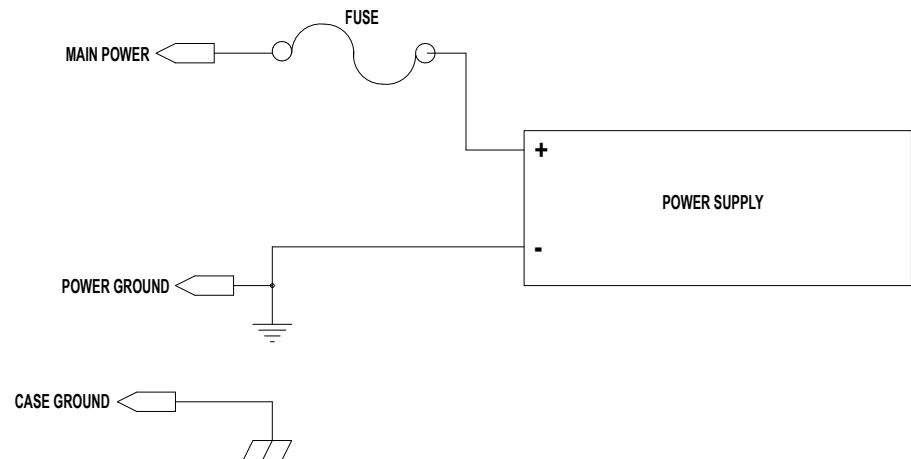
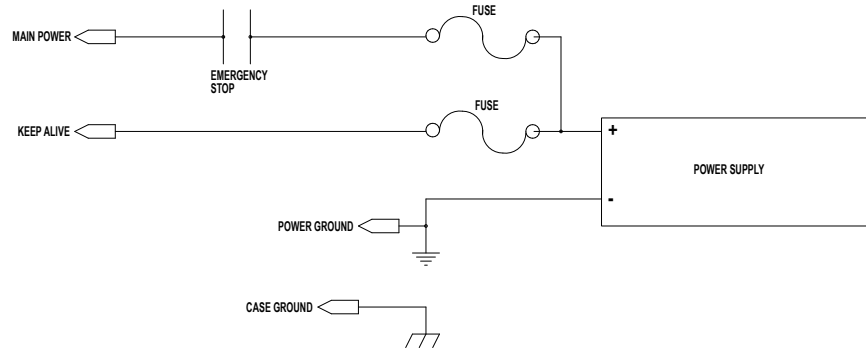

Figure 6-14: ACS Drive Single Supply – Main Power

## 6: SPECIFICATIONS & WIRING



**Figure 6-15: ACS Drive External Cutoff Switch for Emergency Stop**

### 6.6.3 Power Supply Selection

Both unregulated and regulated power supply can be used to power the ACS Drive.

Regulated supplies work well with ACS drive, but additional measures may need to be taken. To prevent regenerative energy from reaching the supply or from damaging the drive, a shunt regulator should be installed. A shunt regulator is available as Tolomatic Part Number 2180-1163 (Applied Motion RC-050, 1000-237). These regulators can support multiple drives when the power supply is sized correctly. This regulator will clamp the dc voltage to within just a couple volts of the supply voltage and either store excess energy or dissipate it with an internal power resistor. When there is the risk of the drive suddenly losing power, the regulator will prevent the drive from being permanently damaged.

When using a single clamp for multiple drives, individual power cables should come directly off of the clamp. They should not be daisy chained between drives. The clamp should be close as possible to the drive which is the source of the Back EMF.

The ACS Drive is intended to run off of an isolated DC power source. The power supply required will depend on the application. A 48V supply will allow the actuator to operate at maximum speed. A 24V supply will result in approximately half the rated velocity. Input current will depend on the actuator power needed in the installation. If operating more than one actuator on the same power supply, add the required power supply rating for each actuator. Maximum power supply current for Tolomatic motors are shown below.

<b>Maximum Power Supply Requirements for Tolomatic Motors</b>			
<b>MOTOR</b>	<b>MOTOR PHASE AMPS PEAK</b>	<b>CALCULATED MAX SUPPLY AMPS</b>	<b>MAX WATTS 24/48V</b>
NEMA 11 - 1 Stack	1.0	0.6	14.4
NEMA 17 - 1 Stack	1.5	0.85	20.4
NEMA 23 - 1 Stack	2.0	1.1	26.4
NEMA 23 - 2 Stack	5.0	2.6	62.4
NEMA 34 - 1 Stack	10.0	5.1	122.4
NEMA 34 - 2 Stack	10.0	5.1	122.4

**Table 6-7: Maximum Power Supply Current for Tolomatic Motors**

To size the power supply, the following formula can also be used to estimate



## 6: SPECIFICATIONS & WIRING

maximum current required:

$$\text{Motor Current (Phase Amps Peak)} * 0.5 + 0.1$$

For example, if the motor is rated at 10 Amps-peak, the calculation would look like:

$$10 * 0.5 + 0.1 = 5.1$$

Converting current (Arms) to power (Watts):

$$\text{Supply power} = \text{current} \times 24\text{V}$$

Example: If 2.3A is needed,  $2.3\text{A} \times 24\text{V} = 55.2\text{W}$ .

### 6.6.4 Suggested Power Supplies:

Switching Power Supply:		
Manufacturer	Tolomatic Part No.	Specs
Meanwell	3604-2147	48V, 2.5A, 120 W
	3604-2148	48V, 5A, 240 W
	3604-2149	48V, 10A, 480 W

Unregulated Power Supply: International Power IP500U36

Bus Fuse: 15 Amp, 125V or equivalent or sized for application

Logic Power Fuse: 2 Amp, 125V or equivalent

Shunt Regulator: Applied Motion RC-50, PN: 1000-237

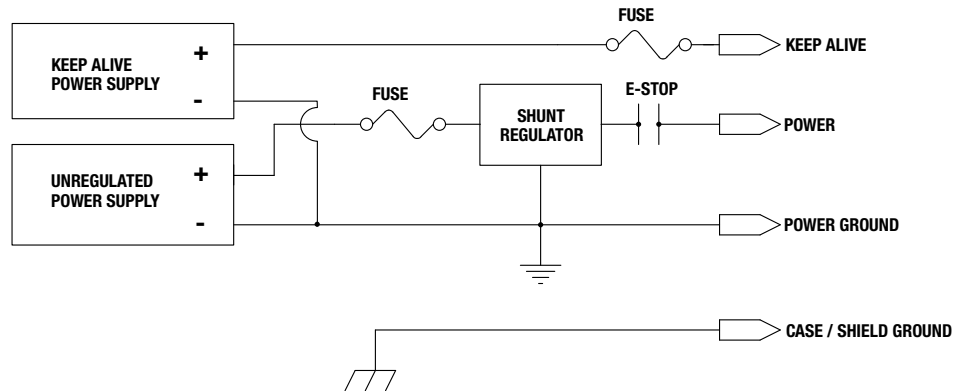

Figure 6-16: Power Supply Configuration with Shunt Regulator

## 7.1 I/O Timing Diagrams

The opto-isolated digital inputs require a minimum of 2ms of time to guarantee that the input signal is registered by the drive. This is an important consideration to take into account, especially if limit switches are used. If limit switches are used, careful consideration should be used to prevent missed triggering due to high velocities. Output timing assumes 10K  $\Omega$  load. Additional software filtering of digital inputs by TMI will increase response time.

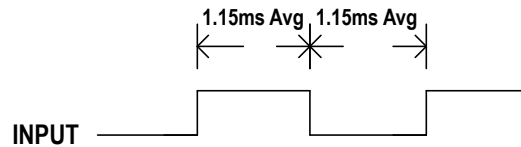

Figure 7-1 Input Requirement

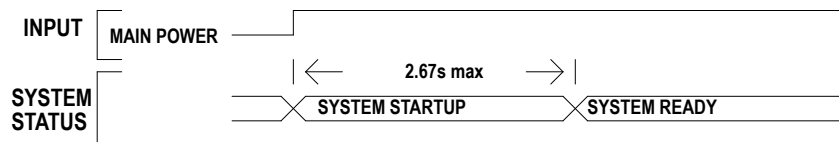

Figure 7-2 System Startup Timing

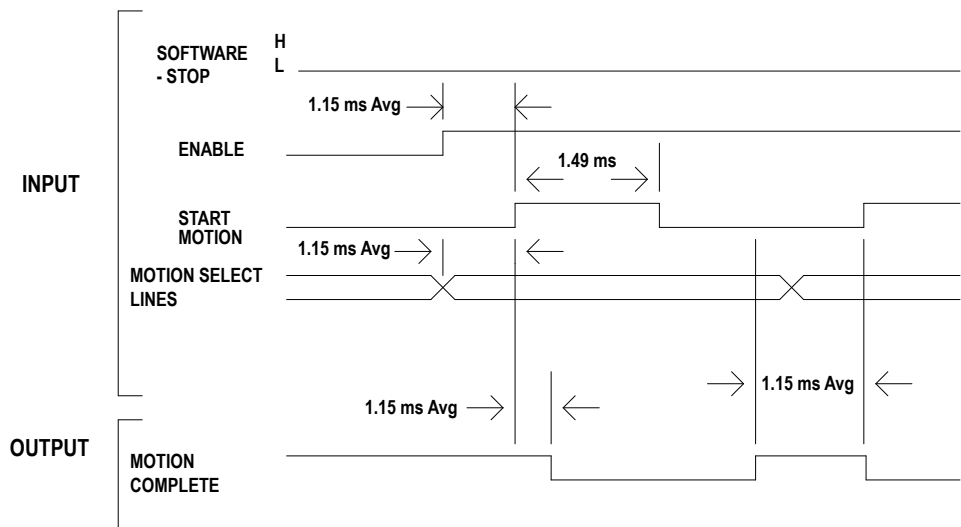

Figure 7-3 Jog Move Timing

# 7: I/O TIMING DIAGRAMS

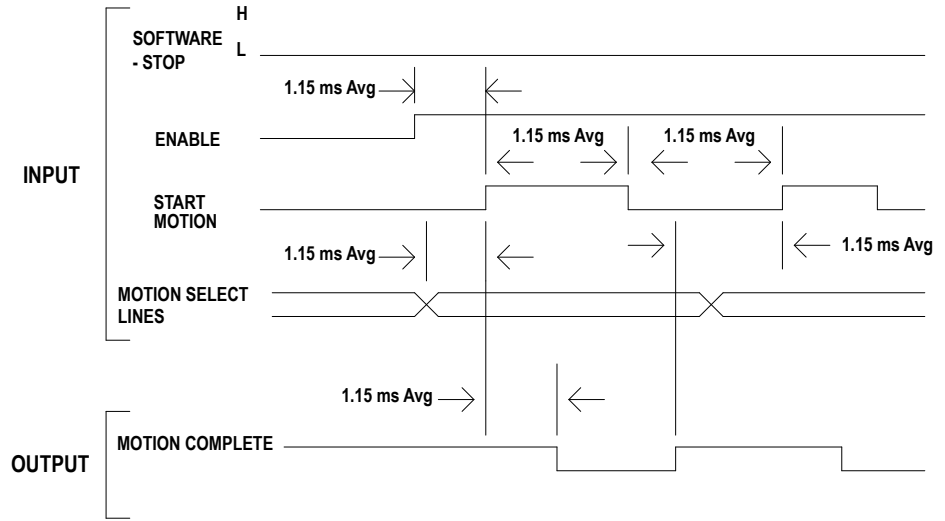

Figure 7-4 Absolute & Incremental Move Timing

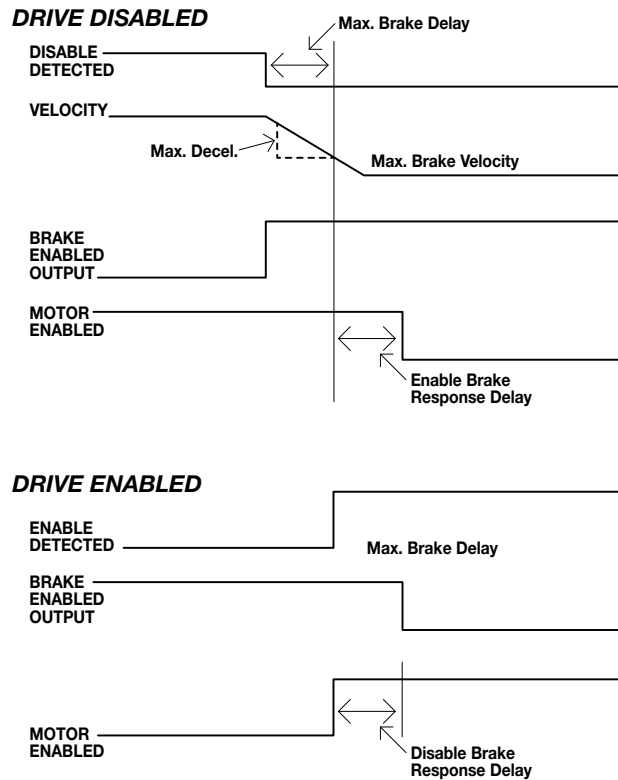

Figure 7-5 Brake Subsystem Timing

### ■ 7.1.1 Move Timing Rules

1. While the Motion Complete signal is low, the drive will ignore Start Motion pulses and Motion Selection lines.
2. If the enable signal is low or Software Stop signal is high, the drive will ignore start motion pulses.

## 8.1 Move Select Logic Table

The Index Move Mode (4/8/16 move commands), require digital inputs to select the desired move for execution. The digital inputs are called Move Select 1 through 4 (MS1-MS4) in the digital input map. To select the desired move command refer to the three logic tables below.

**NOTE 1:** MS# stands for Move Select #

**NOTE 2:** 1 = On; 0 = Off

4 Move Commands Mode Logic Table		
MOVE	MS1	MS2
1	0	0
2	1	0
3	0	1
4	1	1

Table 8-1: 4 Move Commands Mode Logic

8 Move Commands Mode Logic Table			
MOVE	MS1	MS2	MS3
1	0	0	0
2	1	0	0
3	0	1	0
4	1	1	0
5	0	0	1
6	1	0	1
7	0	1	1
8	1	1	1

Table 8-2: 8 Move Commands Mode Logic

## 8: MOVE SELECT LOGIC

---

16 Move Commands Mode Logic Table				
MOVE	MS1	MS2	MS3	MS4
1	0	0	0	0
2	1	0	0	0
3	0	1	0	0
4	1	1	0	0
5	0	0	1	0
6	1	0	1	0
7	0	1	1	0
8	1	1	1	0
9	0	0	0	1
10	1	0	0	1
11	0	1	0	1
12	1	1	0	1
13	0	0	1	1
14	1	0	1	1
15	0	1	1	1
16	1	1	1	1

Table 8-3: 16 Move Commands Mode Logic

## 9.1 LED Codes

LED Indicators	
<b>Green, Off</b>	Motor is not powered (Disabled)
<b>Green, On</b>	Motor is powered (Enabled)
<b>Red, On and Solid</b>	A critical fault has occurred
<b>Red, On and Blinking</b>	A safety fault has occurred
<b>Green, On and Blinking</b> <b>Red, On and Blinking</b>	Drive is in firmware upgrade mode

**Table 9-1: LED Indicators**

To clear a fault, the enable input needs to be lowered, and then raised. Faults can also be cleared by the PC software. Faults that result in a blinking red LED indicator, are cleared automatically once the fault condition is no longer present.

## 9.2 Fault Descriptions and Recovery



**NOTE:** To clear faults; PLC needs to lower/raise the enable digital input or TMI user must press the Enable button on the motion manager

Faults are divided into Safety Faults and Critical Faults.

Safety Faults are configurable. If the fault is configured as a stop motion, the fault will be cleared automatically once the fault condition is no longer present. If a safety fault is enabled and configured for disable motor, the fault will be latched until it is cleared in the same manner as the critical faults described at left.

All Critical Faults will disable the motor when they occur. To clear these faults, the fault condition cannot be present and the enable input line must be lowered and then raised to proceed with motion.

Safety Faults Table	
<b>Positive Limit Switch</b>	Positive limit switch has been reached. If configured to stop motion, motion will be allowed in the reverse direction. The fault will be cleared once the positive limit switch input is no longer active and there is motion in the negative direction.
<b>Negative Limit Switch</b>	The negative limit switch has been reached. If configured as stop motion, motion will be allowed in the positive direction. The fault will be cleared once the negative limit switch input is no longer active and there is motion in the positive direction.

<b>Safety Faults Table</b>	
<b>Position Error</b>	<p>If an encoder is present, the position error fault can be enabled. If encoder position and commanded position differ by a larger magnitude than the defined position error, the position error fault will be activated. If fault is configured as a stop motion, fault will be cleared on next move command. If fault is configured as 'Disable Motor' the enable input must be cycled.</p> <p>NOTE: If force is less than 100%, a position error fault will not be triggered. It will stop and hold position (push mode).</p>
<b>Software Stop</b>	<p>If an input is configured as an Software Stop and fault is enabled, this fault will be activated when the signal level on the pin is high. This fault is configured as a stop motion, it will be cleared after the Software Stop input is lowered and next move is commanded. If fault is configured as 'Disable Motor' the enable input must be cycled. Motion will not be allowed until Software Stop has been cleared.</p>

**Table 9-2: Safety Faults**

<b>Critical Faults Table</b>	
<b>Over Current</b>	Current draw from motor driving circuitry is above drive's rated limit.
<b>Drive Over Temp</b>	Drive temperature is greater than the maximum allowed temperature (75°C).
<b>Drive Over Voltage</b>	Main power voltage exceeds the threshold defined in hardware manual: "Input Power" section.
<b>Drive Under Voltage</b>	Main power voltage below the threshold defined in hardware manual: "Input Power" section.
<b>Flash Error</b>	<p>Memory checksum error or firmware version mismatch. If error occurs at:</p> <p>Power-up – Flash memory checksum error or firmware version mismatch.</p> <p>During Motion – Communication failure to motor driver.</p>
<b>Watchdog Timeout</b>	<p>Firmware did not respond in time. Occasionally this fault is induced from power cycling the drive when the USB cable is connected to a PC. Disconnect USB and power cycle the drive to clear the fault. This fault can also occur if the power supply is too small for the drive, actuator &amp; load and the supply faults and resets, typically occurring during deceleration portion of a move.</p>

**Table 9-3: Critical Faults**



## 10.1 Troubleshooting

### 10.1.1 Troubleshooting the ACS Stepper Drive

SYMPTOM / TROUBLE	POSSIBLE CAUSE / RESOLUTION
No communication to drive	<ol style="list-style-type: none"> <li>1. Check power connection. (See page 6_6 for wiring)</li> <li>2. Try another USB cable.</li> <li>3. Verify that the communication cable is plugged in securely.</li> <li>4. Verify that all drivers are up-to-date.</li> <li>5. Try a different computer.</li> </ol>
Actuator cannot move load	<ol style="list-style-type: none"> <li>1. The load is too large.</li> <li>2. There is too much friction.</li> <li>3. Side load is excessive.</li> <li>4. Power supply does not have enough current capability.</li> <li>5. Current limits are set too low.</li> <li>6. Verify movement with no load attached.</li> <li>7. Verify that the drive has been configured properly for the actuator.</li> </ol>
Drive is overheating	<ol style="list-style-type: none"> <li>1. Ambient temperature is too high.</li> <li>2. Cooling is insufficient.</li> <li>3. Drive spacing is too close.</li> <li>4. Holding current is too high.</li> <li>5. Voltage is too high.</li> </ol>
Actuator is operating erratically	<ol style="list-style-type: none"> <li>1. Motor/encoder signals disconnected, damaged or wired incorrectly.</li> <li>2. Determine if power supply has enough current.</li> <li>3. Check to see if any faults are being generated.</li> <li>4. Verify that the drive has been configured properly for the actuator.</li> <li>5. Verify the issue is not mechanical.</li> <li>6. Verify that the brake is not enabled while attempting motion.</li> </ol>

## 10 : TROUBLESHOOTING

SYMPTOM / TROUBLE	POSSIBLE CAUSE / RESOLUTION
No response from drive in I/O mode	<ol style="list-style-type: none"> <li>1. Verify the enable signal is on.</li> <li>2. Verify that all of the I/O are configured properly.</li> <li>3. Verify wiring to the actuator and drive.</li> <li>4. Disconnect from software or select digital input controlled radio button on mode setup tab.</li> <li>5. Verify that the move index table contains all appropriate data.</li> <li>6. Verify that the drive is seeing I/O using TMI digital I/O tool.</li> <li>7. Home the actuator.</li> </ol>
Red and Green LEDs on, both blinking and no communication (See page 9_1-9_2 for Red LED faults and recovery.)	<ol style="list-style-type: none"> <li>1. Cycle power to drive.</li> <li>2. Verify firmware upgrade completed without interruption.</li> <li>3. Restart firmware upgrade in compatibility mode.</li> </ol>
No Ethernet Communication (Ref. EtherNet/IP User's Guide 3600-4168)	<ol style="list-style-type: none"> <li>1. Check Ethernet cables.</li> <li>2. Verify Ethernet cable is plugged in securely.</li> <li>3. Incorrect combination of IP address, subnet mask &amp; gateway. Check with your network administrator.</li> <li>4. Verify that you can ping drive.</li> </ol>
Red and green LEDs toggling back and forth	<ol style="list-style-type: none"> <li>1. Drive is in upgrade mode. Launch Tolomatic firmware upgrade and reload firmware.</li> </ol>
Audible noise from motor when TMI is connected over USB	<ol style="list-style-type: none"> <li>1. Running TMI and connecting using a virtual server has been known to cause USB connection issues. It is not recommended to control ACS drives using a virtual machine</li> <li>2. Check different USB ports.</li> <li>3. Check different computers.</li> <li>4. Check different USB cables.</li> </ol>

**Table 10-1: Troubleshooting Descriptions**

# Appendix 1

## Motors

There are currently four frame sizes– NEMA 11, NEMA 17, NEMA 23 and NEMA 34 available from Tolomatic (six different motors) – available for operation with the ACS Drive. Each motor is available with an optional differential incremental encoder. All motors come with a short 150mm cable and connector on the motor body.

Tolomatic Motor Specifications						
SPEC	NEMA 11	NEMA 17	NEMA 23 1-Stack	NEMA 23 2-Stack	NEMA 34 1-Stack	NEMA 34 2-Stack
Resistance (Ohms)	3.5	2.4	1.5	0.39	0.138	0.188
Inductance (mH)	2.3	4.5	3.7	1.53	1.13	2.0
Rated Current (Amps-Peak/Phase)	1.0	1.5	2.0	5.0	10.0	10.0
Maximum Torque (in-lbs)	1.85	5.26	7.53	13.4	24.3	53.0
Maximum RPM	1800	2000	1200	2000	2000	1850
Degree per Step	1.8°	1.8°	1.8°	1.8°	1.8°	1.8°
Rotor Inertia (lb-in <sup>2</sup> )	0.006	0.028	0.075	0.133	0.324	0.546

**Table A-1: Tolomatic Stepper Motor Specifications**

Tolomatic Motor Part Numbers		
MOTOR	NO ENCODER	WITH ENCODER
NEMA 11	3604-1779	3604-1780
NEMA 17	3604-1775	3604-1776
NEMA 23 1-Stack	3604-1777	3604-1778
NEMA 23 2-Stack	3604-1954	3604-1955
NEMA 34 1-Stack	3604-1956	3604-1957
NEMA 34 2-Stack	3604-1961	3604-1962

**Table A-2: Tolomatic Stepper Motor Part Numbers**

Encoder Specifications				
MOTOR TYPE	FRAME SIZE	ENCODER	CABLE CONNECTOR PART NUMBER	CABLE TERMINAL PART NUMBER
Bipolar Stepper, 1.8° per Step	NEMA 23	Differential; 500 line (2000 count post quad)	794954-6	50212-8000
Bipolar Stepper, 1.8° per Step	NEMA 34	Differential; 500 line (2000 count post quad)	Molex 15-04-5104 (x1)	inserts: Molex 14-60-0058 (x2)

**Table A-3: Encoder Specifications**

# Appendix 1

MOTOR CONNECTIONS						
3m / 5m / 10m Cable			Motor Connector or Leads			
Wire Color	Alt Color	Tyco Pin	NEMA11	NEMA17	NEMA23 1-Stack	NEMA23 2-Stack Leads
Grn/Yel	Brn	6	6	1	1	Black
Blk #1	Wht	3	4	3	3	Green
Blk #2	Blu	1	3	4	4	Red
Blk #3	Blk	4	1	6	6	White

**Table A-4: NEMA11, 17, 23 Motor Connection pinouts**

34 FRAME MOTOR CONNECTIONS					
3m / 5m / 10m Cable			Motor Connector or Leads		
Wire Color	Alt Color	Phoenix Contact	NEMA34	NEMA34 1-Stack Leads	NEMA34 2-Stack Leads
Grn/Yel	Brn	1	1	Black	Black
Blk #1	Wht	2	2	Green	Green
Blk #2	Blu	4	4	Red	Red
Blk #3	Blk	5	5	Blue	Blue

**Table A-5: NEMA34 Motor Connection pinouts**

ENCODER Connections: US Digital PN E8P-500-197-D-D-M-B Molex Mating Connector: 510221-0600; Molex Contacts: 50079-8100		
WIRE COLOR	MOLEX PIN	SIGNAL
Blue	2	ENC A+
Orange	3	ENC A-
Yellow	5	ENC B+
Gray	6	ENC B-
Black	1	Signal Ground
Red	4	+5VDC

**Table A-6: NEMA11, 17, 23 Encoder Connections and Connector pinouts**

ENCODER Connections: US Digital PN E5-500-394-NE-D-G-D-B Connector: Molex 15-04-5104; Contacts: Molex inserts 14-60-0058 (x2)		
WIRE COLOR	MOLEX PIN	SIGNAL
Blue	6	ENC A+
Orange	5	ENC A-
Yellow	10	ENC B+
Gray	9	ENC B-
Black	2	Signal Ground
Red	7	+5VDC

**Table A-7: NEMA 34 - Encoder Connections and Connector pinouts**

# Appendix 2

## Previous Revisions of Wire Colors for Motor Power Connection pinouts

**NOTE!**

See section 5 for current wire color/pin numbers

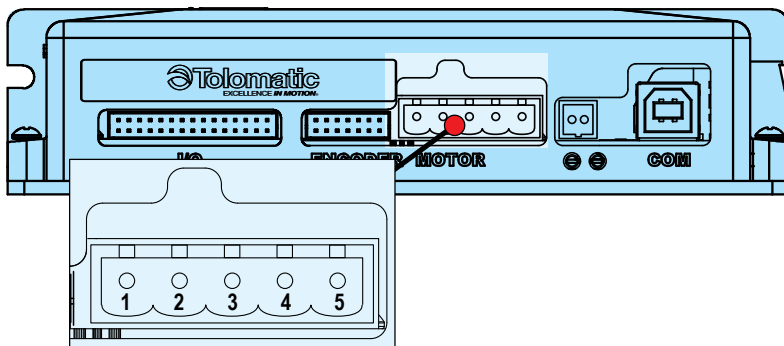

Figure 5-1: Motor Power Connection on ACS Servo Drive (repeated for reference)

	ACS CONNECTOR						MOTOR END
	ALL REVS	REV 0,1	REV 2,3	REV 4,5		REV 6	ALL REVS
3604-1708	1	BLK	GRN/YEL	GRN/YEL	BRN	BRN	6
3604-1709	2	GRN	BLK#1	BLK#1	WHT	WHT	3
3604-1710	4	RED	BLK#2	BLK#2	BLU	BLU	1
	5	WHT	BLK#3	BLK#3	BLK	BLK	4
	3	SHIELD	SHIELD	SHIELD	SHIELD	SHIELD	2

	ACS CONNECTOR			MOTOR END
	ALL REVS	REV 0	REV 1	ALL REVS
3604-2228	1	1 GRN/YEL BRN	BRN	1
3604-2229	2	2 BLK#1 WHT	WHT	2
3604-2230	4	4 BLK#2 BLU	BLU	4
	5	5 BLK#3 BLK	BLK	5
	3	3 SHIELD		3

Table A-8: Previous Revisions of Wire Colors for Motor Power Connection pinouts

## Previous Revisions of Wire Colors for I/O Connection

### NOTE!

See section 5 for current wire color/pin numbers

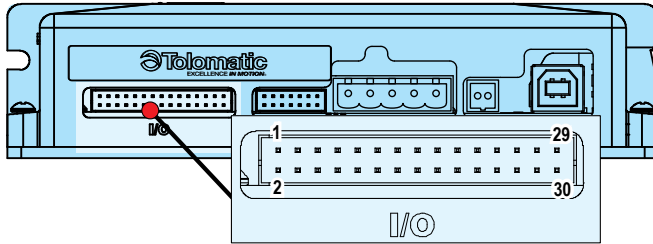

Figure 5-5: I/O Connection on ACS Drive (repeated for reference)

PIN NUMBERS	SIGNAL	CABLE WIRE COLOR			
		REV 0,1	REV 2	REV 3	REV 5
1	Input ISO 1	RED/BLK/WHT	RED/BLK/WHT	PNK/BLK	PNK/BLK
2	Input ISO 2	ORG/GRN	ORG/GRN	ORG/GRN	PNK
3	Input ISO 3	RED/WHT	RED/WHT	RED/WHT	RED/WHT
4	Input ISO 4	GRN/WHT	GRN/WHT	GRN/WHT	TEAL/WHT
5	Input ISO 5	BLU/WHT	BLU/WHT	BLU/WHT	BLU/WHT
6	Input ISO 6	WHT/BLK/RED	WHT/BLK/RED	WHT/BLK/RED	YEL/BLK
7	Input ISO 7	WHT/RED	WHT/RED	WHT/RED	YEL
8	Input ISO 8	ORG/RED	ORG/RED	ORG/RED	ORG/WHT
9	Input ISO COM	GRN/BLK	GRN/BLK	GRN/BLK	TEAL/BLK
10	Output 1 -	RED/BLK	RED/BLK	RED/BLK	RED/BLK
11	Output 1 +	WHT	WHT	WHT	WHT
12	Output 2 -	WHT/BLK	WHT/BLK	WHT/BLK	GRN
13	Output 2 +	BLU	BLU	BLU	BLU
14	Output 3 -	BLU/BLK	BLU/BLK	BLU/BLK	GRY/BLK
15	Output 3 +	ORG	ORG	ORG	ORG
16	Output 4 -	ORG/BLK	ORG/BLK	ORG/BLK	ORG/BLK
17	Output 4 +	RED	RED	RED	RED
20	Case Ground	SHIELD	SHIELD	SHIELD	SHIELD
23	*Step Input	BLU/RED	BLU/RED	BLU/RED	BRN/WHT
24	*Direction Input	RED/GRN	RED/GRN	RED/GRN	BRN
25	No Contact	GRN	GRN	GRN	TEAL
26	No Contact	BLK/RED	BLK/RED	BLK/RED	GRY
27	Analog Out	GRN/BLK/WHT	GRN/BLK/WHT	GRN/BLK/WHT	VIO/WHT
28	Analog In	BLK/WHT/RED	BLK/WHT/RED	BLK/WHT/RED	VIO
29	Signal Ground	BLK	BLK	BLK	BLK
30	Signal Ground	BLK/WHT	BLK/WHT	BLK/WHT	BLK/WHT

Table A-5: Previous Revisions of Wire Colors for I/O Connection

# Appendix 3

---

## Product Warranty

Tolomatic, Inc. warrants all products manufactured by it to be free from defects in material and workmanship for a period of one year from date of shipment by Tolomatic. If, within this period, any product is proven to be defective by Tolomatic, the product will either be repaired or replaced at Tolomatic's option.

This warranty shall not apply to:

1. Products not manufactured by Tolomatic. Warranty of these products will conform and be limited to the warranty actually extended to Tolomatic by its supplier.
2. Damage to the product caused by circumstances beyond the control of Tolomatic, such as negligence, improper maintenance, or storage.
3. This warranty shall be void in the case of: any repairs or alterations made to the product by parties other than Tolomatic.

The foregoing warranties are exclusive and in lieu of all other express and implied warranties. Tolomatic is not subject to any other obligations or liabilities for consequential damages.

## D.1 Certification

CE	<b>Tolomatic</b> EXCELLENCE IN MOTION	CE
<b>EU Declaration of Conformity</b>		
No: 36004704_01		
We the manufacturer,		
<b>Tolomatic</b> 3800 County Road 116 Hamel, MN 55340 USA		
declare under our sole responsibility that the product(s),		
<b>ACS</b>		
<b>All Models</b>		
Fulfills the essential requirements of the following directives:		
<b>EMC Directive (2014/30/EU)</b>		
EN61000-6-1 2007 Immunity		
EN55011: 2009 +A1:2010 Emissions		
<b>RoHS Directive (2011/65/EU, as amended by (EU) 2015/863)</b>		
<b>REACH (Regulation (EC) No 1907/2006)</b>		
Assumption of conformity is based on the application of the harmonized or applicable technical standards and, when applicable or required, a European community notified body certification.		
 _____ Gary Rosengren Director of Engineering		13.05.2021 _____ Date (dd.mm.yyyy)



© 2022 Tolomatic  
Tolomatic. All rights reserved.  
Tolomatic and Excellence In Motion are  
registered trademarks of Tolomatic Incorporated.  
All other products or brand names are  
trademarks of their respective holders.  
[www.tolomatic.com](http://www.tolomatic.com)

202204111422

3604-4183\_11

**Tolomatic**<sup>TM</sup>  
EXCELLENCE *IN MOTION*

COMPANY WITH  
QUALITY SYSTEM  
CERTIFIED BY DNV GL  
= ISO 9001 =  
Certified site: Hamel, MN

#### USA - Headquarters

##### **Tolomatic Inc.**

3800 County Road 116  
Hamel, MN 55340, USA

**Phone:** (763) 478-8000

Toll-Free: **1-800-328-2174**

[sales@tolomatic.com](mailto:sales@tolomatic.com)

[www.tolomatic.com](http://www.tolomatic.com)

#### MEXICO

##### **Centro de Servicio**

Parque Tecnológico Innovación  
Int. 23, Lateral Estatal 431,  
Santiago de Querétaro,  
El Marqués, México, C.P. 76246

**Phone:** +1 (763) 478-8000

[help@tolomatic.com](mailto:help@tolomatic.com)

#### EUROPE

##### **Tolomatic Europe GmbH**

Elisabethenstr. 20  
65428 Rüsselsheim  
Germany

**Phone:** +49 6142 17604-0

[help@tolomatic.eu](mailto:help@tolomatic.eu)

#### CHINA

##### **Tolomatic Automation Products (Suzhou) Co. Ltd.**

No. 60 Chuangye Street, Building 2  
Huqju District, SND Suzhou  
Jiangsu 215011 - P.R. China

**Phone:** +86 (512) 6750-8506

[TolomaticChina@tolomatic.com](mailto:TolomaticChina@tolomatic.com)

All brand and product names are trademarks or registered trademarks of their respective owners. Information in this document is believed accurate at time of printing. However, Tolomatic assumes no responsibility for its use or for any errors

that may appear in this document. Tolomatic reserves the right to change the design or operation of the equipment described herein and any associated motion products without notice. Information in this document is subject to change without notice.

Visit [www.tolomatic.com](http://www.tolomatic.com) for the most up-to-date technical information