

UNGUIDED RODLESS BELT-DRIVE ACTUATOR

The MXB-U rodless actuator is a pre-assembled compact linear belt solution for use in applications with existing guides & supports. This economical actuator features speeds up to 5080 mm/sec (200 in/sec) and thrusts up to 1859N (418 lbf). Built-to-order in stroke lengths up to 10.5 m (414 in).

MXB-U

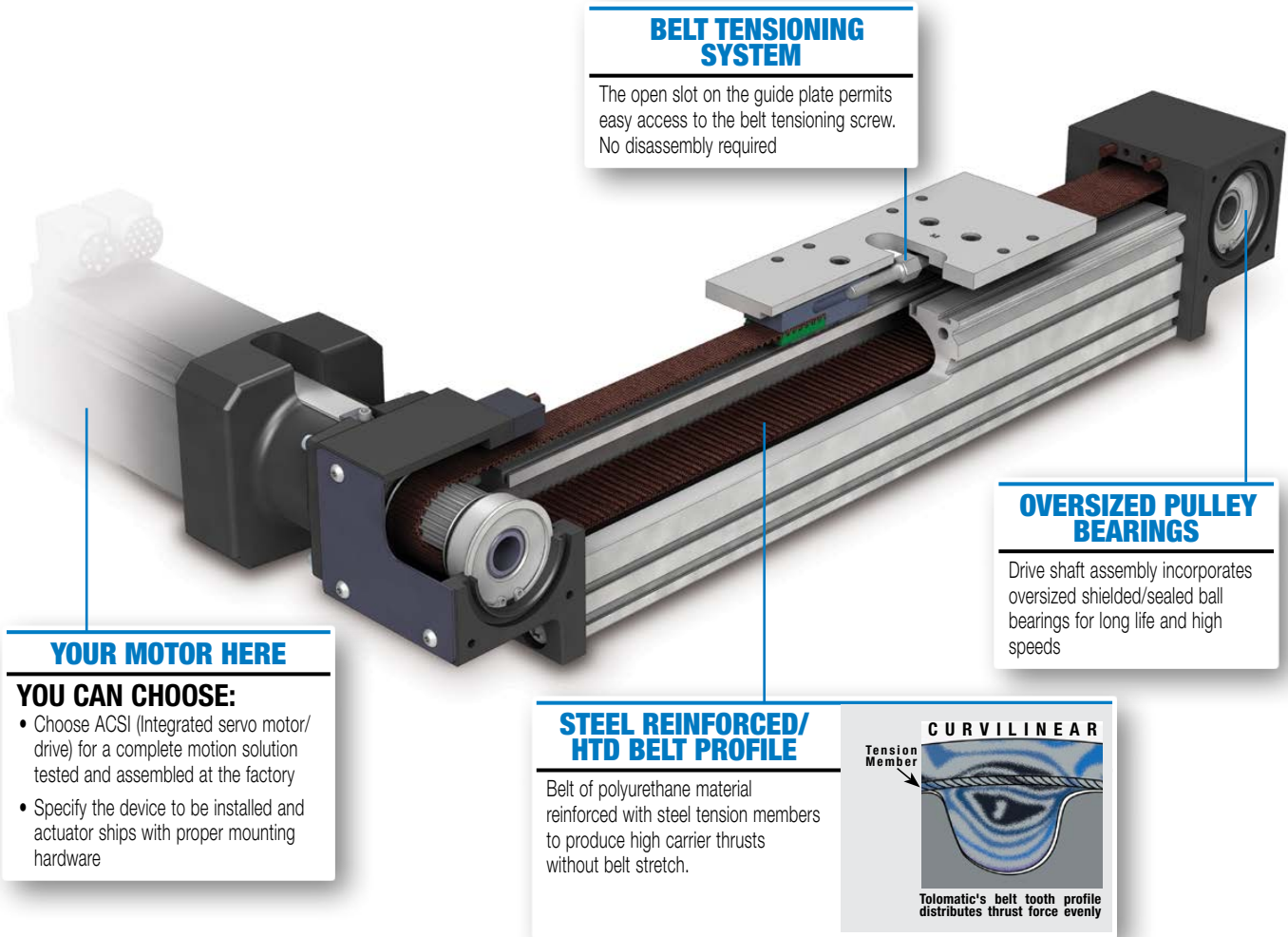

BELT TENSIONING SYSTEM

The open slot on the guide plate permits easy access to the belt tensioning screw. No disassembly required

OVERSIZED PULLEY BEARINGS

Drive shaft assembly incorporates oversized shielded/sealed ball bearings for long life and high speeds

YOUR MOTOR HERE

YOU CAN CHOOSE:

- Choose ACSI (Integrated servo motor/ drive) for a complete motion solution tested and assembled at the factory
- Specify the device to be installed and actuator ships with proper mounting hardware

STEEL REINFORCED/HTD BELT PROFILE

Belt of polyurethane material reinforced with steel tension members to produce high carrier thrusts without belt stretch.

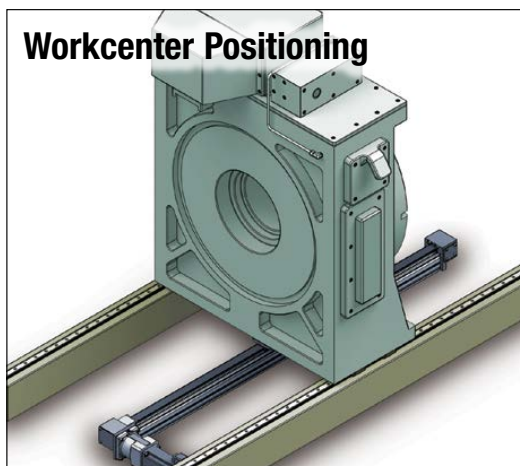
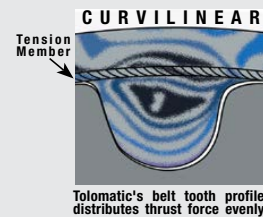

Applications:

- Adhesive dispensing
- Aligning
- Animation
- Assembly
- Automotive
- Camera positioning
- Conveyors
- Cutting
- Diverters
- Inspection
- Laser marking
- Material cutting
- Milling
- Packaging equipment
- Parts transfer
- Pick & place
- Positioning
- Product handling
- Slitting
- Sorting
- Spraying
- Stacking
- Table positioning
- Test stations
- Wire winding

Available Options:

Mounting
Mounting Plates,
Tube Clamps

Sensors
With integrated
mounting

UNGUIDED RODLESS BELT-DRIVE ACTUATOR

MXB-U

Dimensions

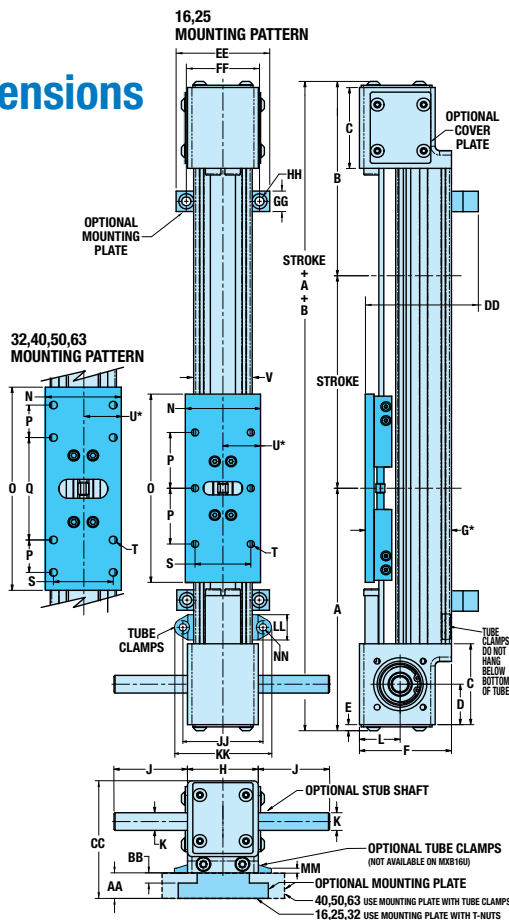

	MXB16	MXB25	MXB32	MXB40	MXB50	MXB63
A	135.3	173.9	187.8	216.6	224.7	275.1
B	119.0	139.3	154.7	192.7	205.0	262.1
C	50.8	58.0	55.9	78.7	82.6	96.1
D	25.4	29.0	25.4	39.4	40.0	45.3
E	3.8	4.4	4.4	4.4	4.4	4.4
F	52.8	66.0	77.5	93.8	110.6	139.3
G*	45.3	61.9	77.4	88.3	109.6	135.5
H	44.5	50.8	69.9	82.6	98.4	111.1
J (LMI)	15.0	57.7	57.7	47.5	47.5	47.5
J (RP)	46.6	57.7	57.7	47.5	47.5	47.5
K	Ø9.53	Ø12.70	Ø12.70	Ø12.70	Ø12.70	Ø12.70
L	26.4	29.2	27.9	39.7	41.5	52.2
N	34.9	54.0	63.5	88.9	95.3	114.3

Measurements in mm

Specifications

MXB SIZE	MAX. THRUST	BELT DEAD LENGTH	MAXIMUM STROKE
	N	mm	mm
16	169	363.0	5,842
25	672	475.5	10,516
32	930	556.0	10,490
40	1,112	633.7	10,465
50	1,446	692.2	10,414
63	1,859	917.2	5,512

Max. Velocity	5,080 mm/sec
Repeatability	± 0.051 mm
Temp. Range	-12 to 54 °C

	MXB16	MXB25	MXB32	MXB40	MXB50	MXB63
O	110.0	135.0	170.0	200.0	216.0	304.8
P	40.0	40.0	27.1	25.4	25.4	40.0
Q	-	-	87.7	114.3	69.8	130.0
S	28.0	40.0	50.0	72.0	79.4	98.3
T	M4x0.7	M6x1.0	M8x1.25	M8x1.25	M8x1.25	M10x1.5
U*	17.5	27.0	31.8	44.5	47.7	57.2
V	30.00	42.00	55.37	64.00	78.74	100.00

OPTIONAL MOUNTING PLATES

AA	15.9	15.9	19.1	25.4	31.8	25.4
BB	6.4	6.4	7.6	-	-	-
CC	68.7	81.9	96.5	119.4	119.4	164.6
DD	60.9	77.7	95.2	106.1	127.4	153.3
EE	60.0	63.5	86.4	127.0	142.2	203.2
FF	44.5	50.8	59.9	112.0	127.0	177.8
GG	25.4	25.4	25.4	20.1	20.1	25.4
HH	Ø5.6 THRU └┘Ø9.4 └┘5.6 (2)	Ø5.6 THRU └┘Ø9.4 └┘5.6 (2)	Ø7.1 THRU └┘Ø11.2 └┘7.1 (2)	Ø7.1 THRU (2)	Ø7.1 THRU (2)	Ø7.1 THRU (2)

OPTIONAL TUBE CLAMPS

	MXB16	MXB25	MXB32	MXB40	MXB50	MXB63
JJ	-	57.0	74.1	82.7	97.5	131.7
KK	-	69.0	87.4	96.7	111.5	150.7
LL	-	18.0	16.0	14.0	14.0	19.0
MM	-	3.6	4.3	3.8	3.8	6.1
NN	-	5.2	7.1	7.1	7.1	10.7

▲*In order for the actuator to operate properly, dimensions "G" and "U" must not vary more than ±0.51mm over the entire length of the stroke.



MADE IN U.S.A.

Tolomatic™

EXCELLENCE IN MOTION

COMPANY WITH QUALITY SYSTEM CERTIFIED BY DNV = ISO 9001 = Certified site: Hamel, MN

USA - Headquarters

Tolomatic Inc.
3800 County Road 116
Hamel, MN 55340, USA
Phone: (763) 478-8000
Toll-Free: **1-800-328-2174**
sales@tolomatic.com
www.tolomatic.com

MEXICO

Centro de Servicio
Parque Tecnológico Innovación
Int. 23, Lateral Estatal 431,
Santiago de Querétaro,
El Marqués, México, C.P. 76246
Phone: +1 (763) 478-8000
help@tolomatic.com

EUROPE

Tolomatic Europe GmbH
Elisabethenstr. 20
65428 Rüsselsheim
Germany
Phone: +49 6142 17604-0
help@tolomatic.eu
www.tolomatic.com/de-de

CHINA

Tolomatic Automation Products (Suzhou) Co. Ltd.
No. 60 Chuangye Street, Building 2
Huqiu District, SND Suzhou
Jiangsu 215011 - P.R. China
Phone: +86 (512) 6750-8506
Tolomatic_China@tolomatic.com

All brand and product names are trademarks or registered trademarks of their respective owners. Information in this document is believed accurate at time of printing. However, Tolomatic assumes no responsibility for its use or for any errors

that may appear in this document. Tolomatic reserves the right to change the design or operation of the equipment described herein and any associated motion products without notice. Information in this document is subject to change without notice.

Visit www.tolomatic.com for the most up-to-date technical information