

APPLICATION SOLUTION: Carton Filling

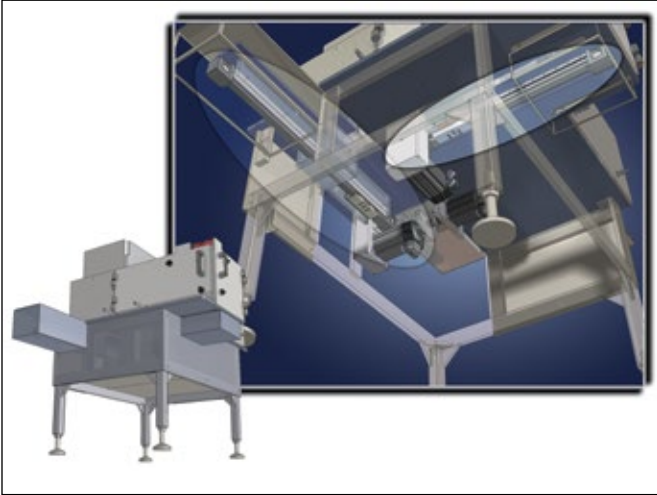

Product Family: Electric Actuators
Product Used: MXB-P Heavy Duty Linear Actuator
Product Type: Standard

Application Requirements:
Stroke: 16 inches and 25 inches
Position Repeatability: +/- 0.002 in (+/- 0.05mm)

Application Description:

Position and fill cartons with correct product count.

Challenge:

A packaging machine builder designed a new, higher speed machine for packaging sugar packets and they needed a carton staging system to keep up with the higher speed of the new machines. Because of the speed and precision required, consistent position repeatability and precise positioning accuracy was a must.

Tolomatic Solution:

Two MXB-P belt-driven actuators were chosen as replacements for the pneumatic system for high positioning accuracy and repeatability as well as higher acceleration/speed capabilities.

Customer Benefit:

- A space-saving, durable, rodless design
- Faster speeds to keep up with new systems
- Precise filling of cartons with correct amount of product

(Reference: 9900-9202)