

## THE ONLY DISC CONE CLUTCH IN THE INDUSTRY

Tolomatic engineers developed the Disc/Cone clutch more than 40 years ago, and it's still the only disc/cone clutch available in the industry today. In this unique design the cone engages a cup on the pilot plate for immediate, positive engagement with no slippage. Tolomatic Disc/Cone Clutches offer high torque and compact profiles in lower cyclic applications.

The Disc/Cone clutch is available in two models; the 1200 series and the 1300 series.

The 1300 series offers a space saving design, while the 1200 series has a cast iron, heat dissipating finned plate which gives it almost 10 times the heat dissipating capacity of the 1300 series model.

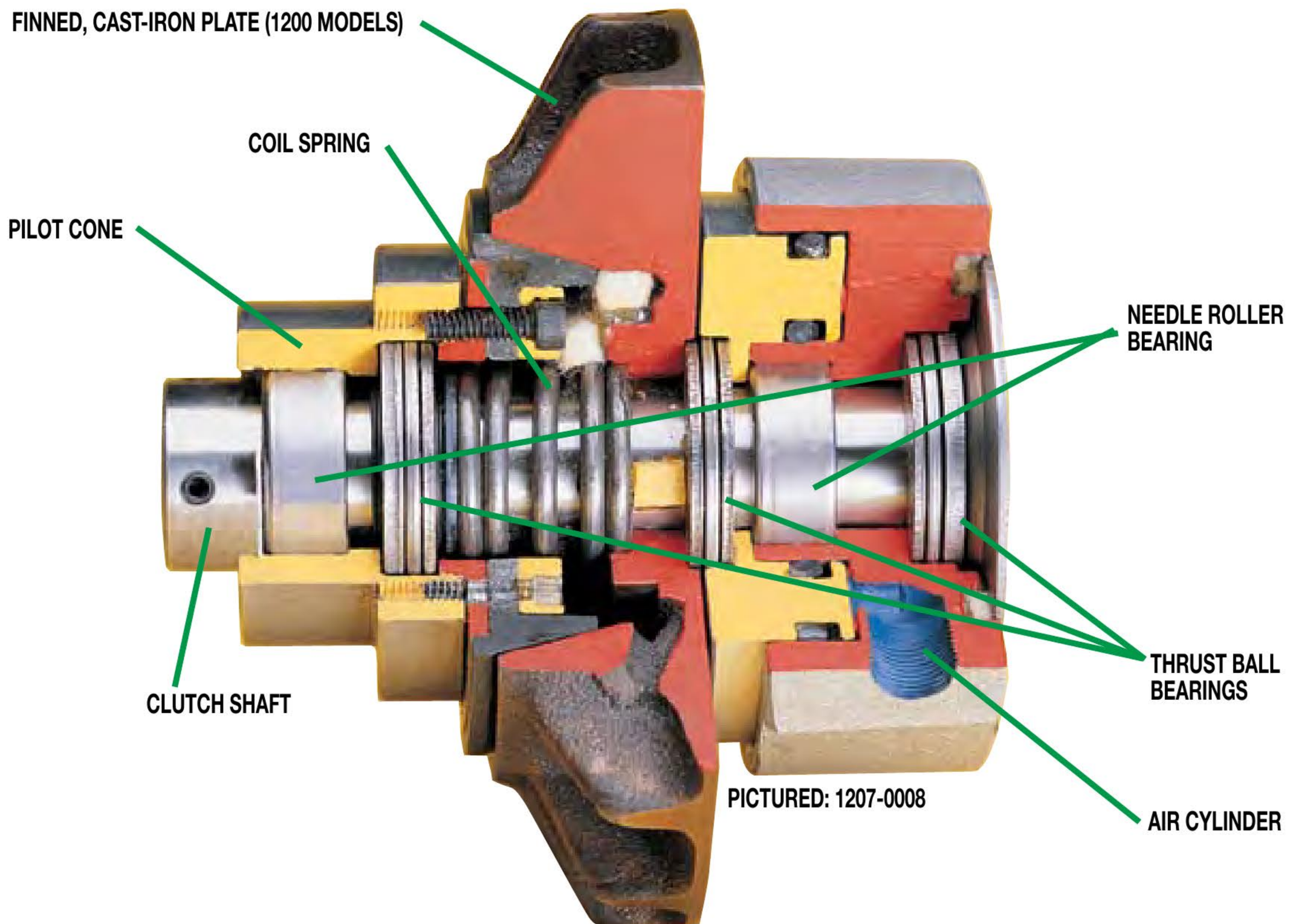

**DISC-PLATE, PILOT-MOUNT DESIGN**

**HIGH TORQUE**

**NO SLIPPAGE**

**SPACE-SAVING DESIGN**

**FAST RESPONSE BASED ON LOW AIR CONSUMPTION**