

REFURBISHMENT SERVICE

- 1: REPLACE THRUST ROD
- 2: REPLACE WIPER/SCRAPER COMPONENTS
- 3: VISUALLY INSPECT FOR ADDITIONAL WORN OR BROKEN COMPONENTS
- 4: CLEAN ROLLER SCREW / NUT ASSEMBLY
- 5: LUBRICATE ROLLER SCREW / NUT ASSEMBLY
- 6: ACTUATOR RE-ASSEMBLY
- 7: FUNCTIONAL TEST

- 3: ACTUATOR IS VISUALLY INSPECTED FOR WORN OR BROKEN COMPONENTS
- 4: CLEAN ROLLER SCREW / NUT ASSEMBLY
- 5: LUBRICATE ROLLER SCREW / NUT ASSEMBLY
 - Factory original lubrication, same as used in new actuators

- 1: REPLACE THRUST ROD
- 2: REPLACE WIPER/SCRAPER COMPONENTS
 - Replacement of these interacting components prevents contaminants from entering the actuator for extended service life

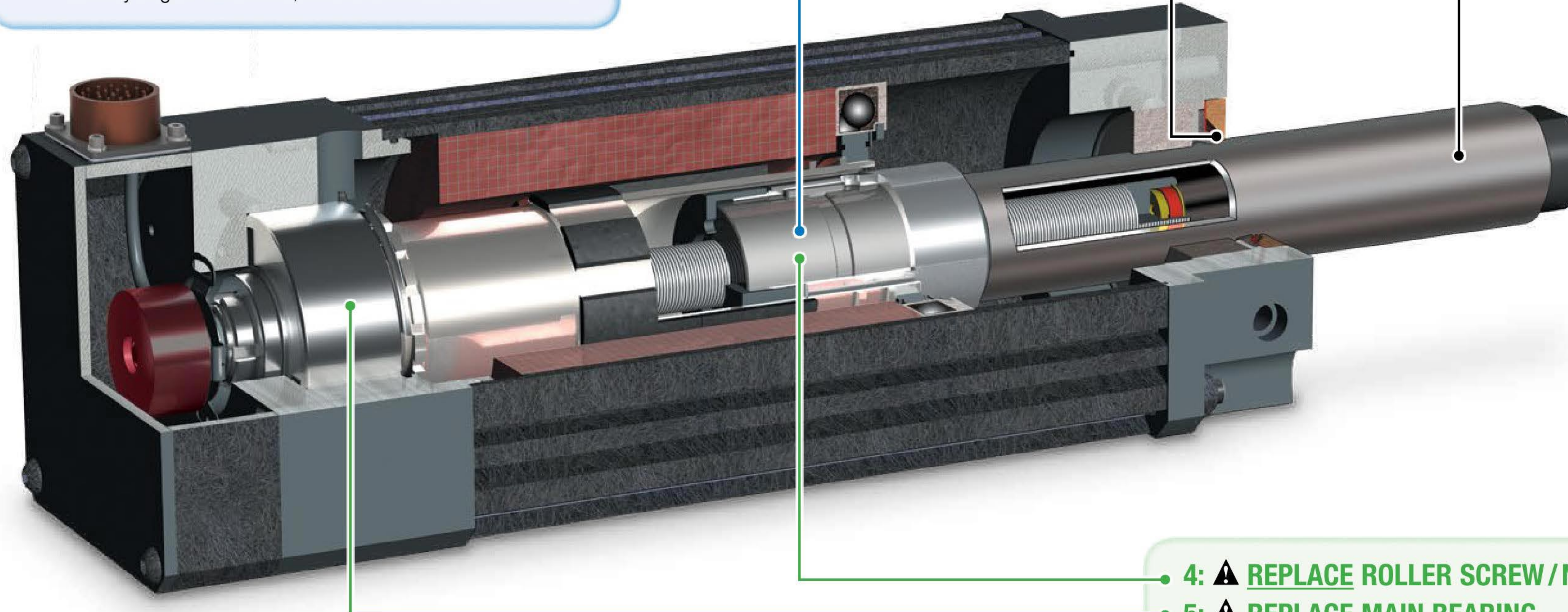

REMANUFACTURING SERVICE

- 1: REPLACE THRUST ROD
- 2: REPLACE WIPER/SCRAPER COMPONENTS
- 3: VISUALLY INSPECT FOR ADDITIONAL WORN OR BROKEN COMPONENTS
- 4: REPLACE ROLLER SCREW / NUT ASSEMBLY
- 5: REPLACE MAIN BEARING
- 6: ACTUATOR RE-ASSEMBLY
- 7: FUNCTIONAL TEST

WARRANTY:
1 year from date of shipment

- 4: ⚠ REPLACE ROLLER SCREW / NUT ASSEMBLY
- 5: ⚠ REPLACE MAIN BEARING
 - These interacting components are critical to create thrust and maintain high force repeatability. All three work together for optimal actuator performance and represent a significant portion of the unit cost. Some damage cannot be determined visually so replacing all three ensures continued reliable service.
 - ⚠ These are critical load bearing components
 - NOTE: Any additional components that need to be replaced will be an additional charge. (e.g. broken connectors, missing rod ends, etc.)

- 6: ACTUATOR RE-ASSEMBLY
- 7: FUNCTIONAL TEST
 - Refurbished and remanufactured ServoWeld actuators must pass the same testing and validation as new ServoWeld actuators
 - NOTE: Any additional components that need to be replaced will be an additional charge. (e.g. broken connectors, missing rod ends, etc.)



3800 County Road 116 • Hamel, MN 55340-9360
 P 763.478.8000 • 1.800.328.2174
 E servoweld@tolomatic.com • F 763.478.8080
 www.tolomatic.com

CONTACT TOLOMATIC FOR AN RMA (RETURN MATERIAL AUTHORIZATION) BEFORE SHIPPING ANY ACTUATOR

Complete Verification Testing is Performed on Each Actuator

Properly applied, every new and remanufactured ServoWeld actuator shipped will provide millions of cycles of maintenance free performance.

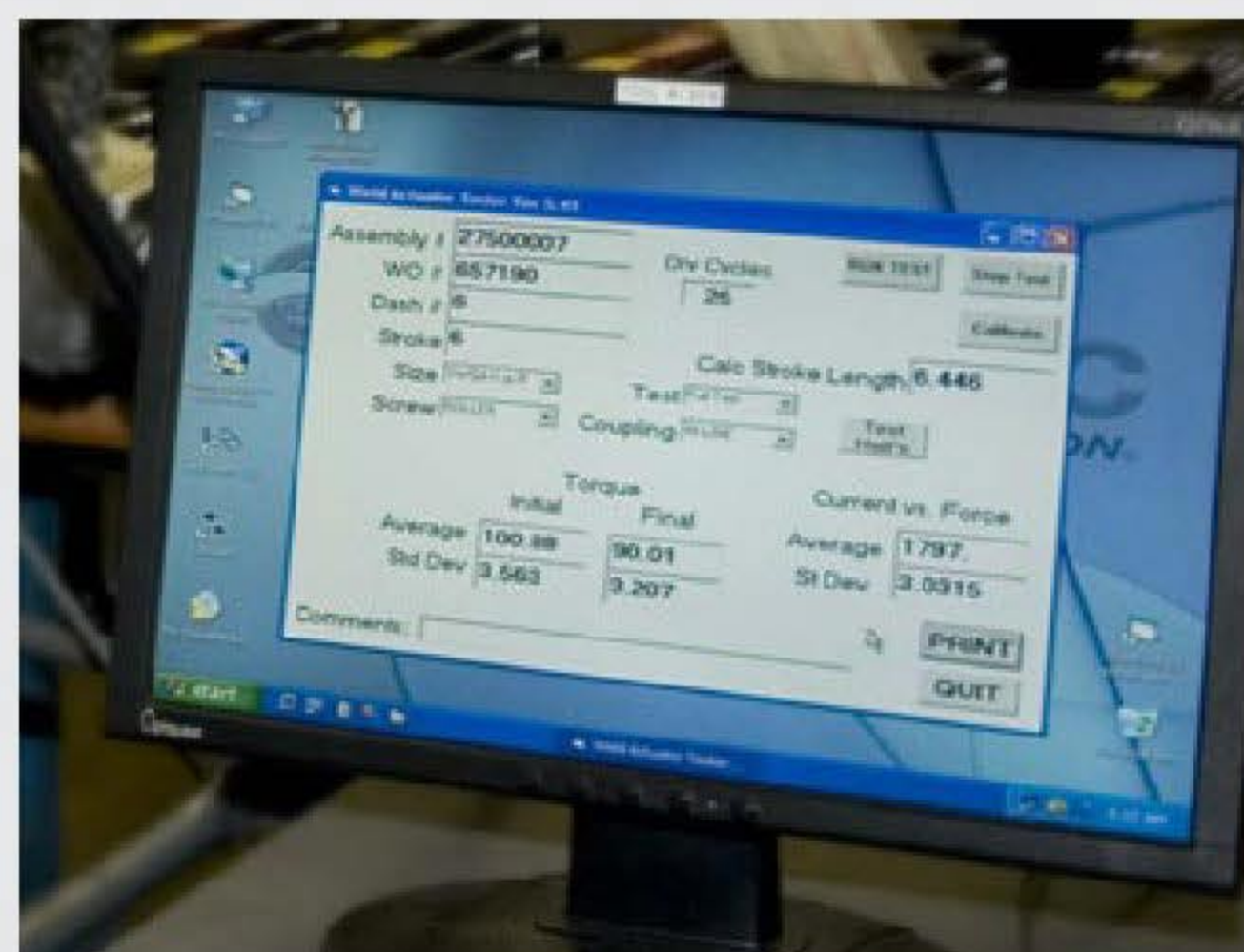

Testing parameter results in progress for the Functional Test procedure.

We verify the performance of each new, refurbished or remanufactured actuator before delivery to ensure they conform to Tolomatic's high standard of performance.

- A. High POT (High Potential/High Voltage Test)

This standard electric motor test procedure is a 3-part test that checks the insulation system of the assembly to verify proper armature and thermal wire insulation.

- B. Functional Testing

Performed with Tolomatic motion control components and dedicated data acquisition equipment. This test quantifies these parameters - stroke length, torque under no load, input current vs average force, input current vs force standard deviation - using an electronic load cell in conjunction with data acquisition equipment.

- C. Electronic phasing of ServoWeld actuator and feedback device (Encoder, Resolver, Feedback Device)

Using a fixed current and a specially designed fixture the feedback device is physically and electronically aligned relative to the phasing of the ServoWeld motor.

- D. Tolomatic System Test

Using a single-axis control unit the test ensures that the feedback device is properly aligned with the poles of the ServoWeld motor.